

User's Manual

ELI43-CP



Revision 1.02

FDI *Future Designs, Inc.*
Your Development Partner
996 A Cleaner Way, Huntsville, AL 35805

Copyright ©2017, Future Designs, Inc., All Rights Reserved

Important Legal Information

Information in this document is provided solely to enable the use of Future Designs, Inc. (FDI) products. FDI assumes no liability whatsoever, including infringement of any patent or copyright. FDI reserves the right to make changes to these specifications at any time, without notice. No part of this document may be reproduced or transmitted in any form or by any means, electronic or mechanical, for any purpose, without the express written permission of Future Designs, Inc. 996 A Cleaner Way, Huntsville, AL 35805.

Microsoft, MS-DOS, Windows, Windows XP, Microsoft Word are registered trademarks of Microsoft Corporation. Other brand names are trademarks or registered trademarks of their respective owners.

Printed in the United States of America.

For more information on FDI or our products please visit www.TeamFDI.com.

©2016 Future Designs, Inc. All rights reserved.

FDI Document PN: MA00066

Revision: 1.02, 02/13/2017



Important Legal Information.....	2
1.0 Introduction	4
2.0 ELI43-CP Box Contents.....	5
3.0 Optional Accessories Recommended for Use (Purchased Separately).....	5
4.0 ESD Warning	5
5.0 Determining the Revision of your ELI.....	5
6.0 Technical Specifications	6
7.0 Connectors.....	7
8.0 Power Details	7
9.0 Extended Display Information Data (EDID)	8
10.0 PWM Control of Backlight	9
11.0 Mechanical View.....	10
12.0 Support	12
12.1 Where to Get Help.....	12
12.2 Useful Links	12



1.0 Introduction

About ELI (the Easy LCD Interface)

ELI® is Future Designs, Inc.’s family of long-life, plug-and-play embedded displays. ELI products are true modular embedded display solutions that require no engineering or lead-time. All ELI products are compatible with a wide range of single board computers including Raspberry Pi, BeagleBone Black and Windows-based units. FDI designed ELI as an embedded display option that requires minimal development time to help customers reach production quickly. Once a product is in production, FDI’s 10-15 year ELI product availability guarantee helps ensure production schedules without the risk of expensive or time consuming redesigns. Learn more about ELI at TeamFDI.com/ELI.

ELI Compatibility

ELI products are compatible with most single board computers, PCs and operating systems. The table below illustrates the results of FDI’s compatibility tests with popular operating systems and platforms. Our results, as indicated in the table, demonstrate ELI’s versatility but the table is not exhaustive. ELI products are designed to work with any single board computer that has an HDMI or DVI output. To submit a question about ELI’s compatibility with a platform or operating system that is not included in the table, contact a member of the FDI support team at Support@teamfdi.com.

ELI43-CR/ELI43-CP Compatibility Chart		Operating System		
		Windows 7 & 10	OSX (Apple)	Linux
Personal Computer Video Source	Intel	✘	TBD	✘
	NVIDIA	✘	TBD	✔
	AMD	✘	✔	✔
SBC Video Source	Beaglebone Black	TBD	N/A	✔
	Intel Compute Stick	✘	N/A	TBD
	Gizmo 2	TBD	N/A	✔
	Raspberry Pi	TBD	N/A	✔ (Config File)

Figure 1. Tested ELI Compatibility



Your ELI Experience

Share your experience connecting ELI devices to various (single board) computers at:
<http://www.teamfdi.com/edid/#edidform>.

2.0 ELI43-CP Box Contents

- ELI43-CP

3.0 Optional Accessories Recommended for Use (Purchased Separately)

- 12V DC (+/- 5%) 2A Power Supply with a center positive barrel plug
 - 2.1mm I.D. x 5.5mm O.D. x 9.5mm (All ELI units operate from +12V DC so this is the recommended power supply input voltage for the entire Family. ELI43-CP units from Rev 3.0 and greater are also capable of operation from a range of +5 to 24V DC (+/- 5%)
- USB Type A to Mini Type B Cable (For touch)
- HDMI Cable (Type A Male)

4.0 ESD Warning



Figure 2. Electrostatic Sensitive Device

Our ELI units are shipped in a protective anti-static package. Do not subject the module to high electrostatic potentials. Exposure to high electrostatic potentials may cause damage to the boards that will not be covered under warranty. General practice for working with static sensitive devices should be followed when working with this device.

5.0 Determining the Revision of your ELI

All ELI units have a label on the board to identify the part number and revision. An example of an ELI label is shown below.



6.0 Technical Specifications

Table 1. Technical Specifications

Screen Size (inches):	4.3
Display Technology:	TFT LCD TN panel anti-glare
Resolution:	480 x 272 (WQVGA)
Brightness (nits typical):	470
Contrast Ratio (typical):	500:1
Aspect Ratio:	16:9
Interface Input Mode:	HDMI/DVI
Colors:	16M (24 bit)
Horizontal Viewing Angle:	70/70°
Vertical Viewing Angle:	70/50°
Surface:	Anti-glare
Touch Screen:	Projected Capacitive
Touch Screen Interface (mA typical/max):	USB Device (24/47)
Touch Panel Hardness:	>7H
Touch Panel Force (gF max):	80
Active Area (in mm W x H):	95.04 x 53.86
Response Time (ms):	24
Backlight:	10 LED (5S x 2P)
Backlight Life (K hours typical):	20
Backlight Power Consumption (mW Typical):	600
Operating Temperature:	-20° to 70° C
Storage Temperature:	-30° to 80° C
Input Voltage:	Rev. ≤ 2.x: +12VDC ± 5% Rev. ≥ 3.0: +5 to 24VDC ± 5%
Power Consumption (ma typical/max)	106/250
RoHS Compliant:	Yes
Dimensions (in mm W x H x D)	116.84 x 72.26 x 19.10
Mounting:	#4 screw mounts in 4 corners
Weight (grams)	106



7.0 Connectors

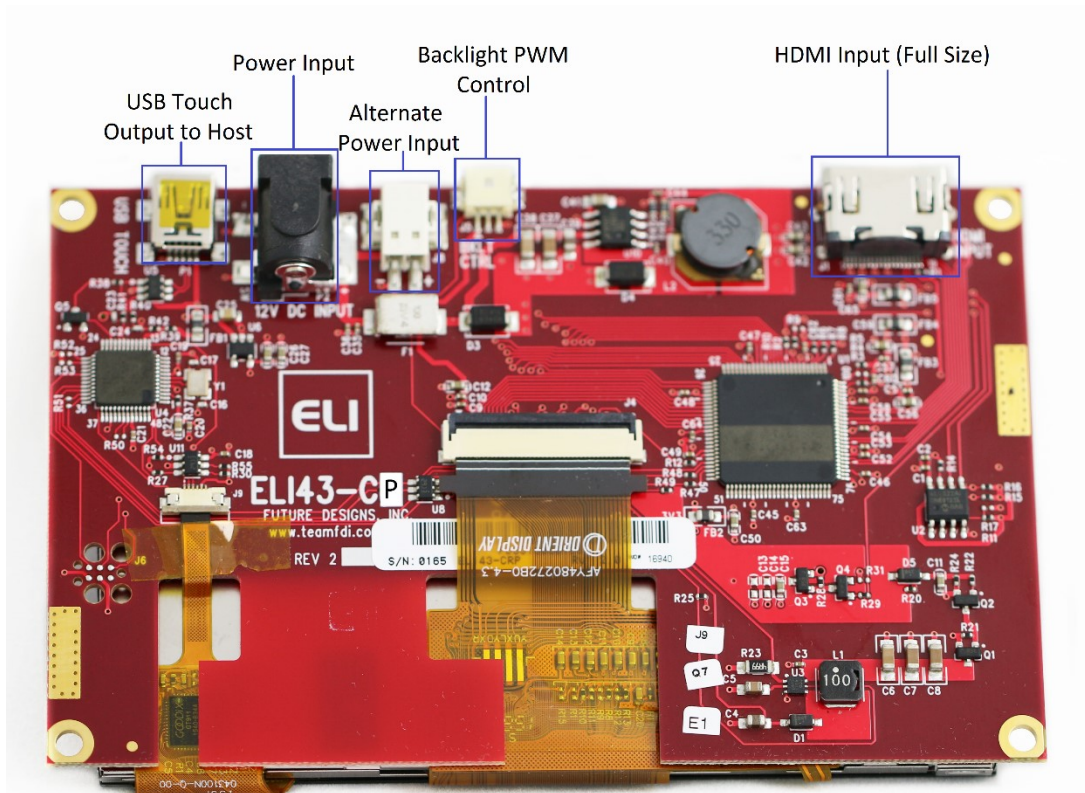

Figure 3. ELI43-CP Connectors

8.0 Power Details

A 12VDC (+/- 5%) power supply with a 2.0A output will power any board from the ELI Family. This allows a common, off-the-shelf power supply such as the [T1071-P5P-ND](#) to be used for quick demos or prototyping across the entire ELI Family. In general, any power supply with a 2.1mm center positive plug that provides 12VDC will be acceptable if it can provide enough current to power the particular ELI unit being used. On the ELI43-CP, plug power into the (P2) connector.

Revision ≥ 3.0 adds the ability to use power supplies ranging from +5 to 24V DC $\pm 5\%$ (2.0A) with ELI43-CP boards.

For volume production applications, the input power can be optimized for your particular ELI unit and lower capacity power supplies can be used.

In cases where the barrel connector is not desired, you can use the alternate power input connector (J8) with supports directly plugging in 20-26 AWG wire with maximum 5A current per contact. The datasheet for this J8 connector (PCB terminal block - PTSM 0,5/ 2-2,5-H SMD WH R24 – 1814634) can be found at <http://tinyurl.com/1814634>.



To verify that the ELI43-CP unit is correctly powered you may check the 12VDC input with a Fluke meter or scope by probing the +12V and GND contacts, shown below. Please verify that the +12VDC is present, is within the +/- 5% tolerance and is free from excessive noise or AC ripple.

Note: If using an input that is within the acceptable range of Rev 3.0 ELI43-CP boards, +5VDC to +24VDC (+/- 5%), please keep in mind that the 12V Test points should be at the voltage of your chosen power supply (5-24VDC).

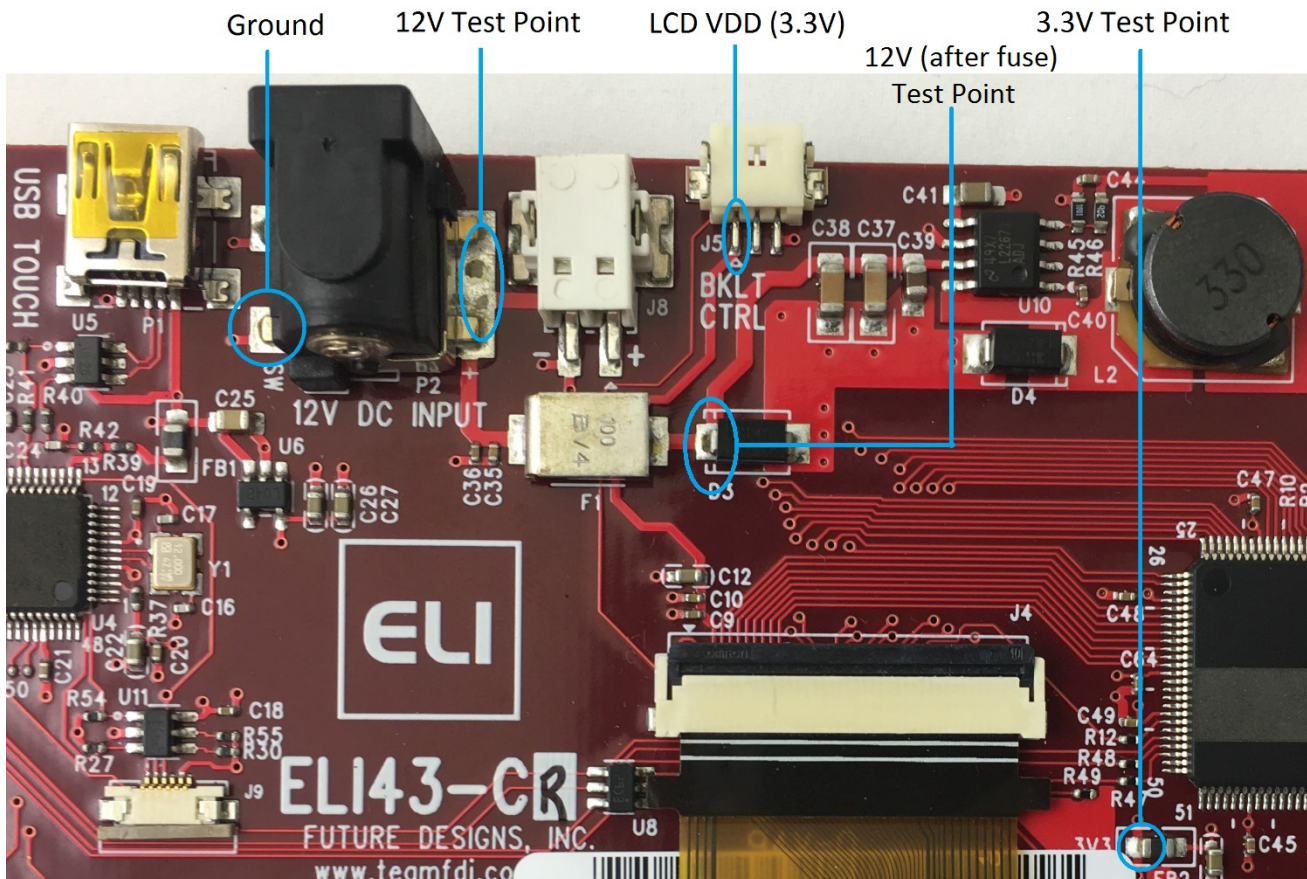

Figure 4. ELI43-CP Power Test Points

9.0 Extended Display Information Data (EDID)

ELI uses Extended Display Identification Data (EDID) for automatic configuration with many operating systems. You can find out more on our website at <http://www.teamfdi.com/edid/>.



10.0 PWM Control of Backlight

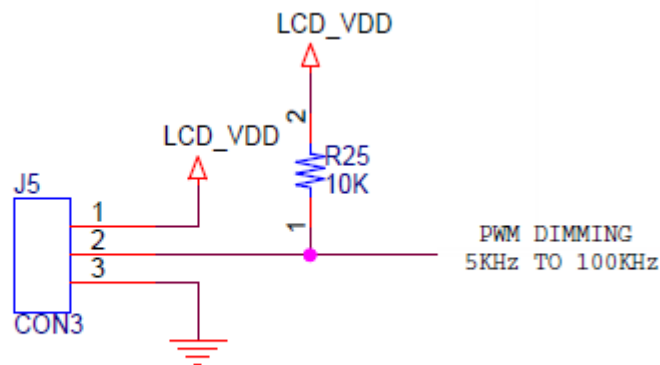

OPTIONAL PROCESSOR PWM BACKLIGHT CONTROL

Figure 5. PWM Backlight Control

All ELI products are designed to reduce power consumption when required. To reduce the power consumption of the backlight/ELI, the user can connect an externally generated Pulse Width Modulated (PWM) signal to pin 2 of J5. This signal must be between 5KHz and 100KHz. On the ELI side we softly pull the PWM dimming signal to LCD_VDD providing 100% backlight power when no PWM signal is applied at J5. In the ELI43-CR and ELI43-CP, power consumption can be controlled from 1.27W to 0.43W with the PWM signal.

If the external system is capable of providing the PWM dimming signal at 3.3V DC, there is no need to connect pin 1 to the cable. ELI provides this signal when the external system needs this voltage to generate the PWM dimming signal.



11.0 Mechanical View

- Tape used to secure the LCD to the PCB is: 3M VHB 4956 ½” width
- 4 screw holes on the ELI43-CP accept up to #4 size screws to mount ELI43-CP into an enclosure and to connect to the system ground.
- The exposed ground pads may be used to connect the ELI43-CP PCB directly to the LCD using copper or aluminum foil tape. This practice meets ESD requirements.

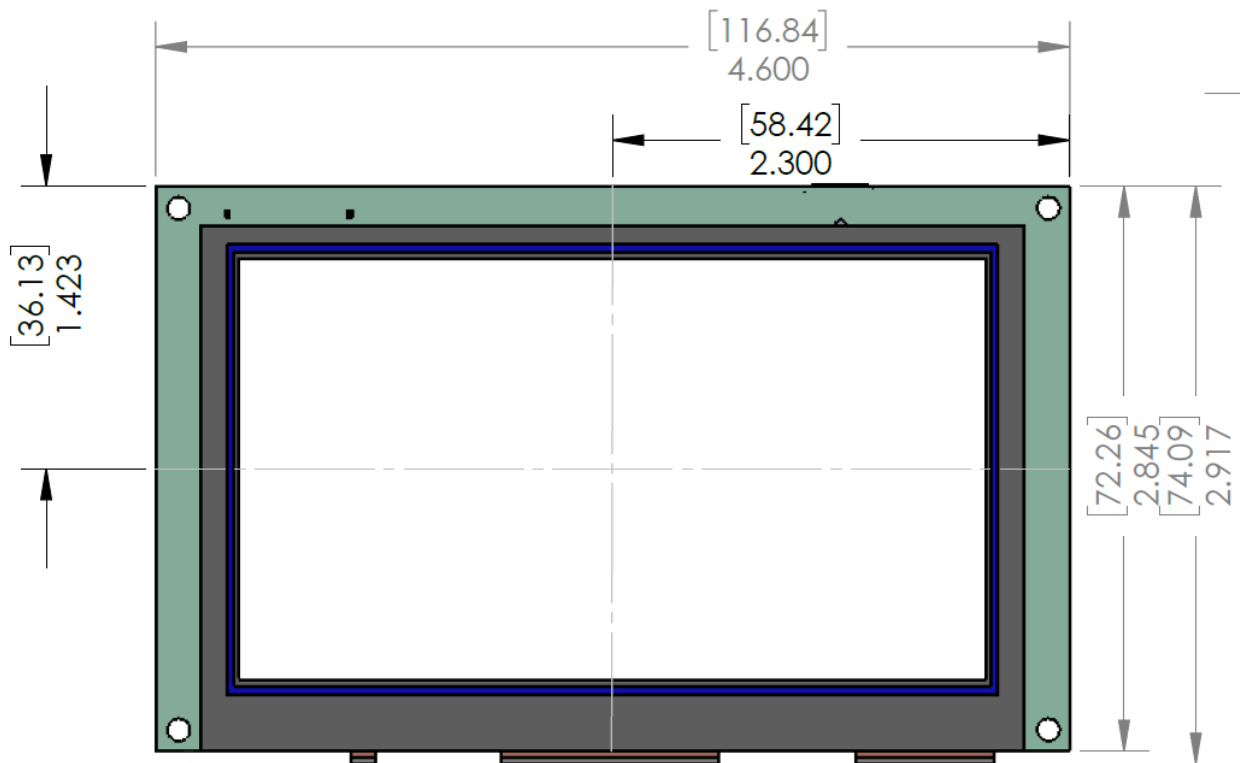

Figure 6. Front View with Measurements



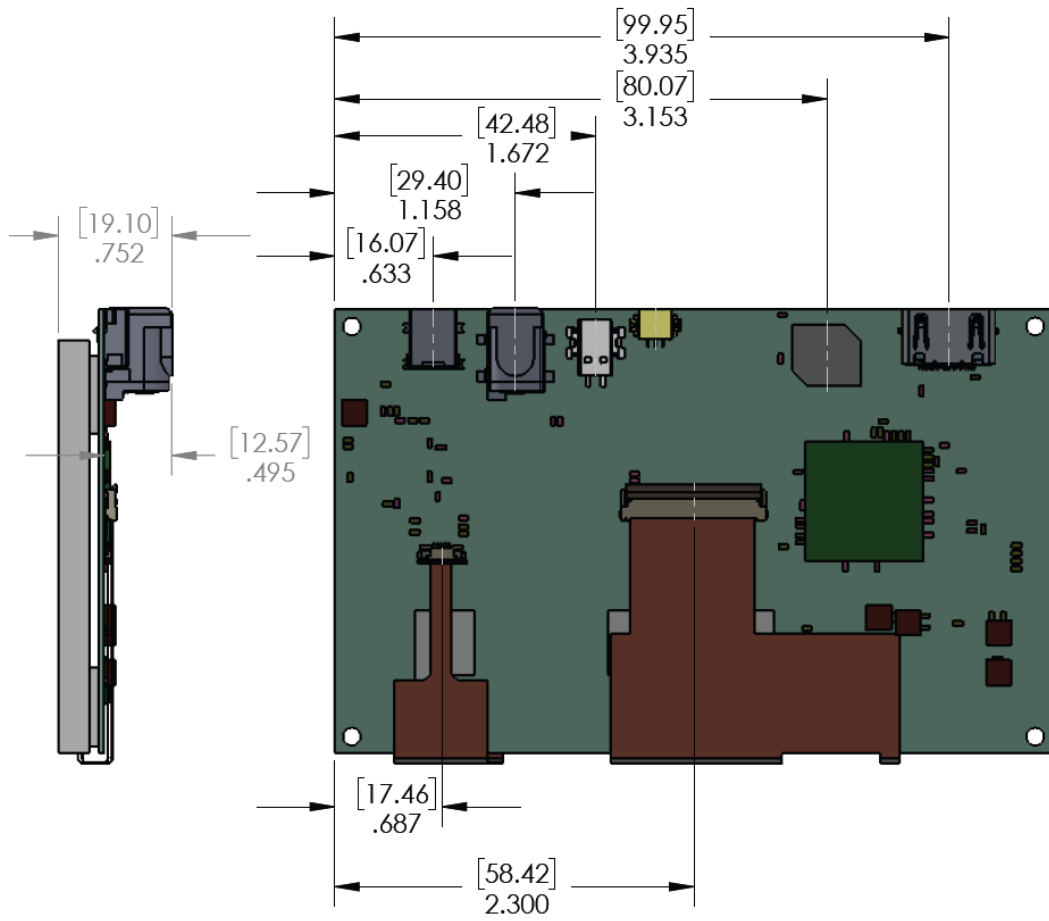

Figure 7. Side and Back Views with Measurements



12.0 Support

12.1 Where to Get Help

Online technical support is available at <http://www.teamfdi.com/support/>

12.2 Useful Links

- Future Designs, Inc. Forums: <http://www.teamfdi.com/forum>
- ELI43-CP Product Page: <http://www.teamfdi.com/product-details/eli43-cp>
- ELI Software User's Manual: <http://www.teamfdi.com/wp-content/uploads/ELI-Software-Users-Manual.pdf>
- Tell us about your ELI experience: <http://www.teamfdi.com/edid/#edidform>
- EDID Information Page: <http://www.teamfdi.com/edid/>



X-ON Electronics

Largest Supplier of Electrical and Electronic Components

Click to view similar products for [Display Modules](#) category:

Click to view products by [Future Designs](#) manufacturer:

Other Similar products are found below :

[P6153-PR](#) [TDP0700T800480PCAP](#) [P6171DPR-DC-RS](#) [P6171DPR-DC-U](#) [MIKROMEDIA 4 FOR STM32F4 CAPACITIVE FPI](#)
[MIKROMEDIA 3 FOR STM32F4 CAPACITIVE FPI](#) [TN0216ANVNANN-GN00](#) [TN0104ANVAANN-GN00](#) [TN0181ANVNANN-GN00](#)
[MIKROMEDIA 5 FOR TIVA CAPACITIVE](#) [MIKROMEDIA 4 FOR TIVA CAPACITIVE](#) [MIKROMEDIA 4 FOR PIC32MZ CAPACITIVE](#)
[RVT43ULFNWC03 V4](#) [SM-RVT101HVBNWCA0](#) [SM-RVT35HHBFWCA0](#) [SM-RVT35HHBNWCA0](#) [SM-RVT43HLBFWCA0](#) [SM-](#)
[RVT43HLBNWCA0](#) [SM-RVT50HQBFWCA0](#) [SM-RVT50HQBNWCA0](#) [SM-RVT70HSBFWCA0](#) [SM-RVT70HSBNWCA0](#) [11769](#)
[MIKROMEDIA FOR DSPIC33](#) [MIKROMEDIA FOR PIC24](#) [MIKROMEDIA FOR PIC32](#) [MIKROMEDIA FOR STELLARIS M3](#)
[MIKROMEDIA HMI 3.5 RES](#) [MIKROMEDIA HMI 5](#) [MIKROMEDIA PLUS FOR FT90X](#) [MIKROMEDIA PLUS FOR PIC32MX7 SHIELD](#)
[MIKROMEDIA PROTO SHIELD](#) [MIKROMEDIA 5 FOR TIVA](#) [MIKROMEDIA 5 FOR TIVA SHIELD](#) [MIKROMEDIA 7 FOR STM32F4](#)
[MIKROMEDIA CONNECT SHIELD](#) [MIKROMEDIA FOR ARM](#) [MIKROMEDIA FOR PSOC5LP](#) [MIKROMEDIA GAMING SHIELD](#)
[MIKROMEDIA HMI 4.3 UXB](#) [MIKROMEDIA HMI 5 RES](#) [MIKROMEDIA HMI 5 UXB](#) [MIKROMEDIA HMI 7](#) [MIKROMEDIA HMI](#)
[BREAKOUT BOARD](#) [RVT50UQTNWC05](#) [RVT70AQFNWC00](#) [18207](#) [PIS-0260](#) [GEN4-ULCD-50D-PI](#) [GEN4-ULCD-70D](#)