

Features

- Low forward voltage, high current capability
- High surge current capability.
- Super fast recovery time for switching mode application.
- Low power loss.
- Glass passivated chip junctions.
- Lead-free parts meet environmental standards of MIL-STD-19500/228

Mechanical data

- Epoxy : UL94-V0 rated flame retardant
- Case : JEDEC TO-220AC molded plastic body over passivated chip
- Lead : Axial leads, solderable per MIL-STD-202, Method 208 guaranteed
- Polarity: As marked
- Mounting Position : Any

Package outline

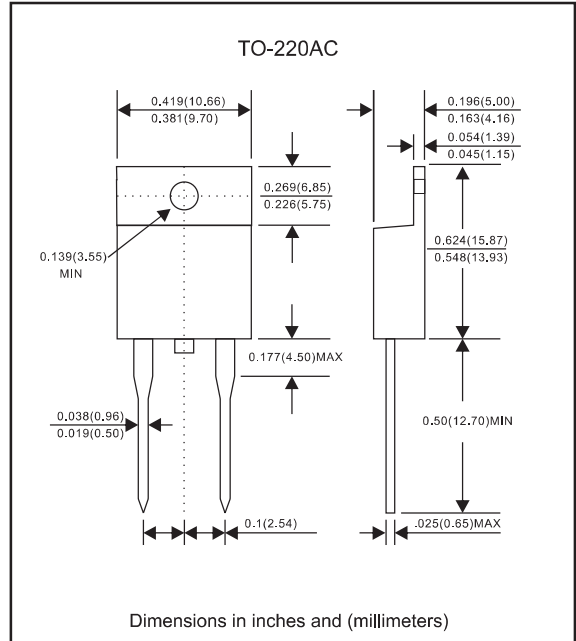

Maximum ratings (AT $T_A=25^{\circ}\text{C}$ unless otherwise noted)

| PARAMETER | SYMBOLS | MUR810G | MUR820G | MUR840G | MUR860G | UNIT |
|--|------------------|-------------|---------|---------|---------|------|
| Maximum repetitive peak reverse voltage | V _{RRM} | 100 | 200 | 400 | 600 | V |
| Maximum RMS voltage | V _{RMS} | 70 | 140 | 280 | 420 | V |
| Maximum DC blocking voltage | V _{DC} | 100 | 200 | 400 | 600 | V |
| Maximum average forward rectified current | I _O | 8 | | | | A |
| Peak forward surge current 8,3ms single half sine-wave(JEDEC method) | I _{FSM} | 100 | | | | A |
| Operating junction temperature range | T _J | -55 to +175 | | | | °C |
| Storage temperature range | T _{STG} | -65 to +175 | | | | °C |

Electrical Characteristics (AT $T_A=25^{\circ}\text{C}$ unless otherwise noted)

| PARAMETER | SYMBOLS | MUR810G | MUR820G | MUR840G | MUR860G | UNIT |
|--|-----------------|-----------|---------|---------|---------|----------|
| Maximum forward voltage at I _F =8A | V _F | 0.98 | | 1.30 | 1.50 | V |
| Maximum reverse recovery time per leg (Note 1) | t _{rr} | 35 | | | 50 | ns |
| Maximum DC reverse current at T _J =25°C at rated DC blocking voltage per leg at T _J =125°C | I _R | 10 500 | | | | uA uA |

Thermal Characteristics

| PARAMETER | SYMBOLS | MUR810G | MUR820G | MUR840G | MUR860G | UNIT |
|---|------------------|---------|---------|---------|---------|------|
| Typical thermal resistance junction to case per leg | R _{θJC} | 2.0 | | | | °C/W |

Note 1: Reverse recovery time test condition, I_F=0.5A, I_R=1.0A, I_{RR}=0.25A

Rating and characteristic curves

FIG.1-TYPICAL FORWARD CURRENT DERATING CURVE

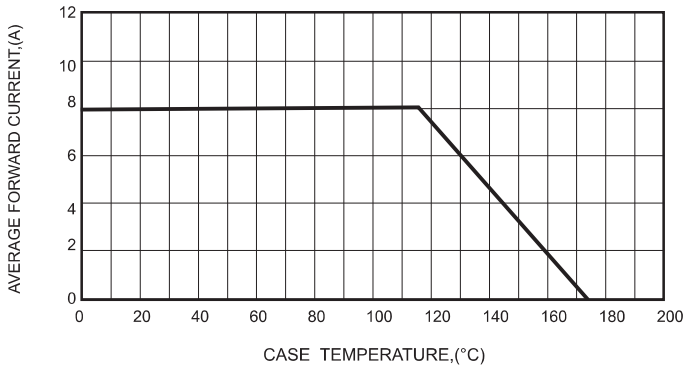

FIG.2-TYPICAL FORWARD CHARACTERISTICS

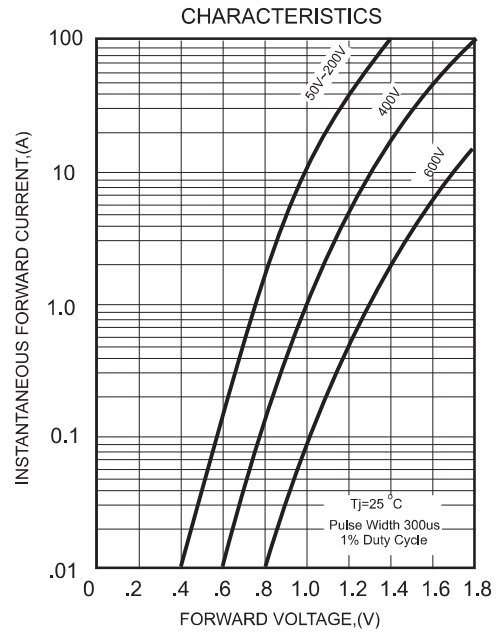

FIG.3-MAXIMUM NON-REPETITIVE FORWARD SURGE CURRENT

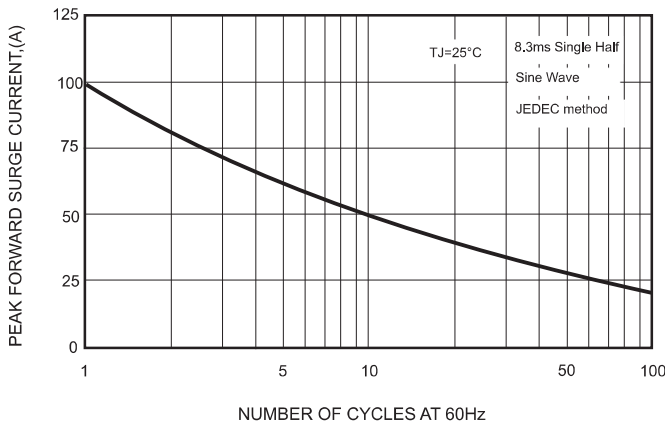

FIG.4 - TYPICAL REVERSE CHARACTERISTICS

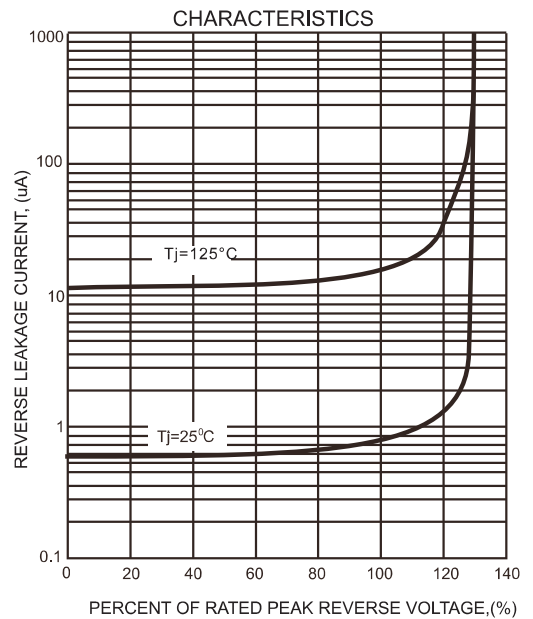
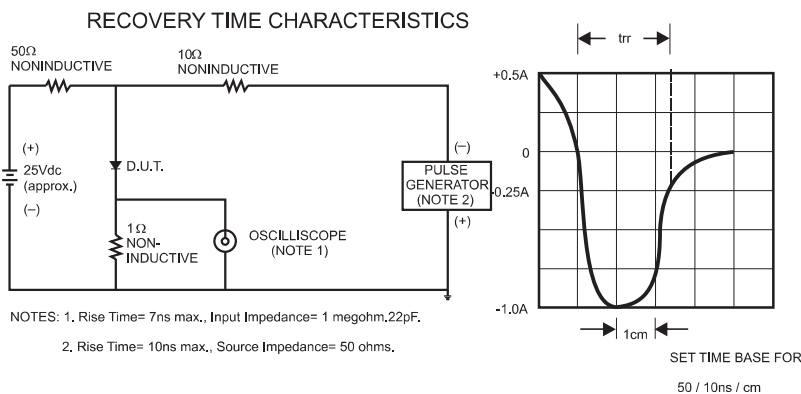
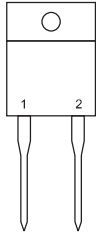
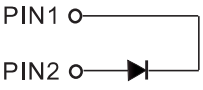

FIG.5- TEST CIRCUIT DIAGRAM AND REVERSE RECOVERY TIME CHARACTERISTICS



NOTES: 1. Rise Time= 7ns max., Input Impedance= 1 megohm,22pF.
2. Rise Time= 10ns max., Source Impedance= 50 ohms.

Pinning information

| Pin | Simplified outline | Symbol |
|----------------------------|---|---|
| Pin1 cathode Pin2 anode |  |  |

Marking

| Type number | Marking code |
|-------------|--------------|
| MUR810G | MUR810G |
| MUR820G | MUR820G |
| MUR840G | MUR840G |
| MUR860G | MUR860G |

X-ON Electronics

Largest Supplier of Electrical and Electronic Components

Click to view similar products for [Rectifiers](#) category:

Click to view products by [FUXINSEMI](#) manufacturer:

Other Similar products are found below :

[70HFR40](#) [FR105 R0](#) [RL252-TP](#) [1N5397](#) [1N4005-TR](#) [1N4007-BP](#) [UFS120Je3/TR13](#) [20ETS12S](#) [RRE02VS6SGTR](#) [MS306](#) [A1N5404G-G](#)
[CRF02\(T5L,TEMQ\)](#) [ACGRB207-HF](#) [CLH07\(TE16L,Q\)](#) [CLH03\(TE16L,Q\)](#) [1N5395-TP](#) [UES1302](#) [ACGRC307-HF](#) [ACEFC304-HF](#) [DZ-](#)
[1380](#) [85HFR60](#) [40HFR60](#) [70HF120](#) [85HFR80](#) [SCF7500](#) [SM100](#) [ACGRA4001-HF](#) [SKN70/08](#) [NTE5819](#) [NTE5827](#) [NTE5828](#) [NTE5911](#)
[NTE5915](#) [NTE6104](#) [NTE6163](#) [NTE6164](#) [NTE6165](#) [NTE6364](#) [TSD3G](#) [SET130312](#) [NRVUS110VT3G](#) [UES1106](#) [UES1306](#)
[NRVUS240VT3G](#) [D5FE60-5063](#) [R4000GPS-TP](#) [D4015L56TP](#) [UES1306HR2](#) [FX20K120](#) [D20XB60-7101](#)