

Features

- 600W peak pulse power capability with a 10/1000 μ s waveform, repetition rate (duty cycle): 0.01%.
- Low profile surface mounted application in order to optimize board space.
- Excellent clamping capability.
- Low incremental surge resistance.
- Fast response time from 0V to VBR, typically less than 1 ps for uni-directional & 5 ns for bi-directional types.
- Glass passivated chip junction.
- Lead-free parts meet RoHS requirements.
- Compliant to Halogen-free

Mechanical data

- Epoxy: UL94-V0 rated flame retardant
- Case : Molded plastic, DO-214AA / SMB
- Terminals : Solder plated, solderable per MIL-STD-750, Method 2026
- Polarity : Indicated by cathode band
- Mounting Position : Any

Package outline

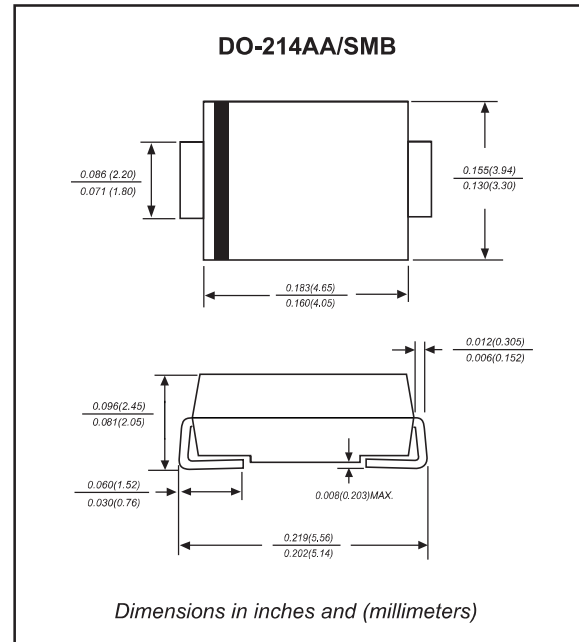

Maximum ratings (AT $T_A=25^\circ\text{C}$ unless otherwise noted)

PARAMETER	CONDITIONS	Symbol	MIN.	TYP.	MAX.	UNIT
Peak power dissipation	with a 10/1000 us waveform, Note 1 & Fig. 1	P_{PPM}			600	W
Peak pulse current	with a 10/1000 us waveform	I_{PPM}	See table 1			A
Steady state power dissipation	at $T_L=75^\circ\text{C}$ lead length 0.375" (9.5 mm)	$P_{M(AV)}$			5.0	W
Peak forward surge current	8.3ms single half sine-wave superimposed on rated load (jedec method), note 2	I_{FSM}			100	A
Maximum instantaneous forward voltage	for uni-directional types only, at 50A, see note 3	V_F			3.5/5.0	V
Operating junction temperature range		T_J	-55		+150	$^\circ\text{C}$
Storage temperature range		T_{STG}	-55		+150	$^\circ\text{C}$

Note 1. Non-repetitive current pulse, per Fig. 3 and derated above $T_A=25^\circ\text{C}$ per Fig. 2

2. Measured on 8.3 ms single half sine-wave or equivalent square wave, duty cycle=4 pulses per minute maximum

3. $V_F < 3.5\text{V}$. for devices of $V_{BR} < 200\text{V}$, and $V_F < 5.0\text{V}$. for devices of $V_{BR} > 201\text{V}$

Electrical characteristics (at $T_A=25^{\circ}\text{C}$ unless otherwise noted)

Type Number		Reverse Stand-Off Voltage	Breakdown Voltage Min. @ I_T	Breakdown Voltage Max. @ I_T	Test Current	Maximum Clamping Voltage @ I_{PP}	Peak Pulse Current	Reverse Leakage @ V_{RMW}
(Uni)	(Bi)	$V_{RMW}(V)$	$V_{BR\ MIN}(V)$	$V_{BR\ MAX}(V)$	$I_T\ (mA)$	$V_C(V)$	$I_{PP}(A)$	$I_R(\mu A)$
P6SMB6.8A	P6SMB6.8CA	5.80	6.45	7.14	10.0	10.5	57.1	1000.0
P6SMB7.5A	P6SMB7.5CA	6.40	7.13	7.88	10.0	11.3	53.1	500.0
P6SMB8.2A	P6SMB8.2CA	7.02	7.79	8.61	10.0	12.1	49.6	200.0
P6SMB9.1A	P6SMB9.1CA	7.78	8.65	9.55	1.0	13.4	44.8	50.0
P6SMB10A	P6SMB10CA	8.55	9.50	10.5	1.0	14.5	41.4	10.0
P6SMB11A	P6SMB11CA	9.40	10.5	11.6	1.0	15.6	38.5	5.0
P6SMB12A	P6SMB12CA	10.2	11.4	12.6	1.0	16.7	35.9	5.0
P6SMB13A	P6SMB13CA	11.1	12.4	13.7	1.0	18.2	33.0	5.0
P6SMB15A	P6SMB15CA	12.8	14.3	15.8	1.0	21.2	28.3	5.0
P6SMB16A	P6SMB16CA	13.6	15.2	16.8	1.0	22.5	26.7	5.0
P6SMB18A	P6SMB18CA	15.3	17.1	18.9	1.0	25.2	23.8	5.0
P6SMB20A	P6SMB20CA	17.1	19.0	21.0	1.0	27.7	21.7	5.0
P6SMB22A	P6SMB22CA	18.8	20.9	23.1	1.0	30.6	19.6	5.0
P6SMB24A	P6SMB24CA	20.5	22.8	25.2	1.0	33.2	18.1	5.0
P6SMB27A	P6SMB27CA	23.1	25.7	28.4	1.0	37.5	16.0	5.0
P6SMB30A	P6SMB30CA	25.6	28.5	31.5	1.0	41.4	14.5	5.0
P6SMB33A	P6SMB33CA	28.2	31.4	34.7	1.0	45.7	13.1	5.0
P6SMB36A	P6SMB36CA	30.8	34.2	37.8	1.0	49.9	12.0	5.0
P6SMB39A	P6SMB39CA	33.3	37.1	41.0	1.0	53.9	11.1	5.0
P6SMB43A	P6SMB43CA	36.8	40.9	45.2	1.0	59.3	10.1	5.0
P6SMB47A	P6SMB47CA	40.2	44.7	49.4	1.0	64.8	9.3	5.0
P6SMB51A	P6SMB51CA	43.6	48.5	53.6	1.0	70.1	8.6	5.0
P6SMB56A	P6SMB56CA	47.8	53.2	58.8	1.0	77.0	7.8	5.0
P6SMB62A	P6SMB62CA	53.0	58.9	65.1	1.0	85.0	7.1	5.0
P6SMB68A	P6SMB68CA	58.1	64.6	71.4	1.0	92.0	6.5	5.0
P6SMB75A	P6SMB75CA	64.1	71.3	78.8	1.0	103	5.8	5.0
P6SMB82A	P6SMB82CA	70.1	77.9	86.1	1.0	113	5.3	5.0
P6SMB91A	P6SMB91CA	77.8	86.5	95.5	1.0	125	4.8	5.0
P6SMB100A	P6SMB100CA	85.5	95.0	105	1.0	137	4.4	5.0
P6SMB110A	P6SMB110CA	94.0	105	116	1.0	152	3.9	5.0
P6SMB120A	P6SMB120CA	102	114	126	1.0	165	3.6	5.0
P6SMB130A	P6SMB130CA	111	124	137	1.0	179	3.4	5.0

※ For Bi-directional type having VRWM of 10 Volts and less, the IR limit is double

Electrical characteristics (at $T_A=25^\circ\text{C}$ unless otherwise noted)

Type Number		Reverse Stand-Off Voltage	Breakdown Voltage Min. @ I_T	Breakdown Voltage Max. @ I_T	Test Current	Maximum Clamping Voltage @ I_{PP}	Peak Pulse Current	Reverse Leakage @ V_{RMW}
(Uni)	(Bi)	$V_{RMW}(V)$	$V_{BR\ MIN}(V)$	$V_{BR\ MAX}(V)$	$I_T\ (mA)$	$V_C(V)$	$I_{PP}(A)$	$I_R(\mu A)$
P6SMB150A	P6SMB150CA	128	143	158	1.0	207	2.9	5.0
P6SMB160A	P6SMB160CA	136	152	168	1.0	219	2.7	5.0
P6SMB170A	P6SMB170CA	145	162	179	1.0	234	2.6	5.0
P6SMB180A	P6SMB180CA	154	171	189	1.0	246	2.4	5.0
P6SMB200A	P6SMB200CA	171	190	210	1.0	274	2.2	5.0
P6SMB220A	P6SMB220CA	185	209	231	1.0	328	1.8	5.0
P6SMB250A	P6SMB250CA	214	237	263	1.0	344	1.7	5.0
P6SMB300A	P6SMB300CA	256	285	315	1.0	414	1.4	5.0
P6SMB350A	P6SMB350CA	300	333	368	1.0	482	1.2	5.0
P6SMB400A	P6SMB400CA	342	380	420	1.0	548	1.1	5.0
P6SMB440A	P6SMB440CA	376	418	462	1.0	602	1.0	5.0

※ For Bi-directional type having V_{RWM} of 10 Volts and less, the I_R limit is double

Rating and characteristic curves

Fig.1 - PEAK PULSE POWER RATING CURVE

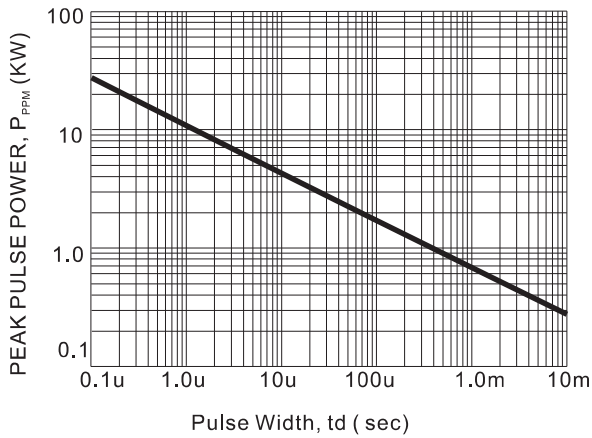

Fig.2 - PULSE DERATING CURVE

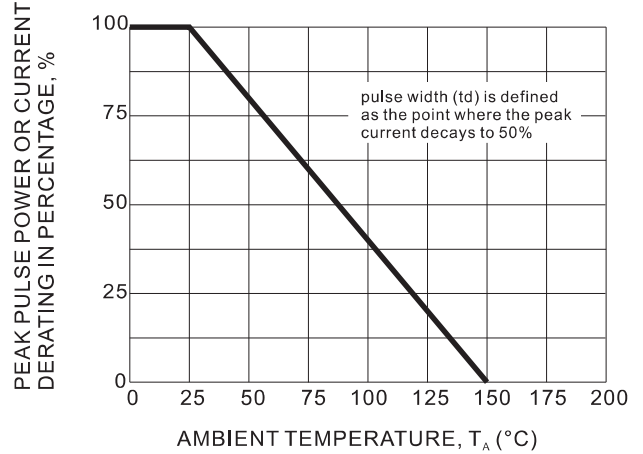

Fig.3 - PULSE WAVEFORM

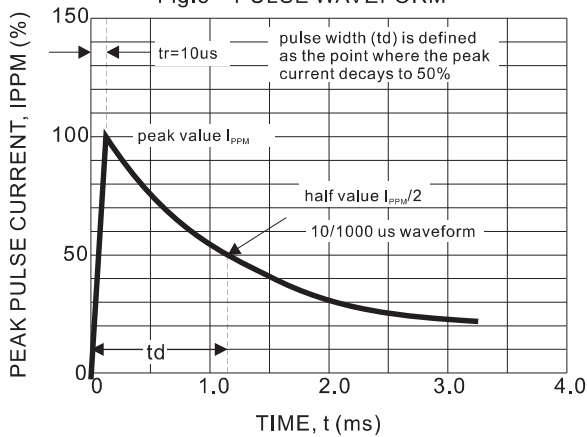

Fig.4 - TYPICAL JUNCTION CAPACITANCE

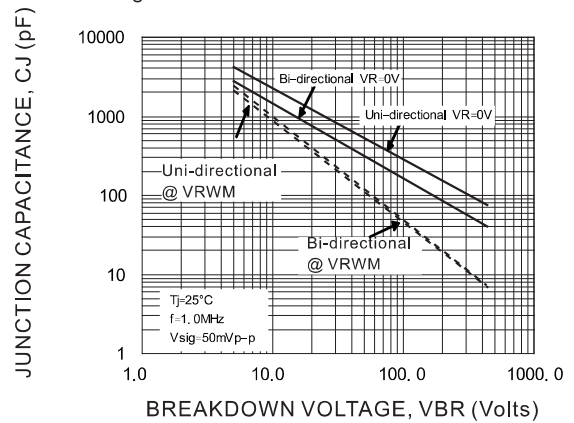

Fig.5 - STEADY STATE POWER DERATING CURVE

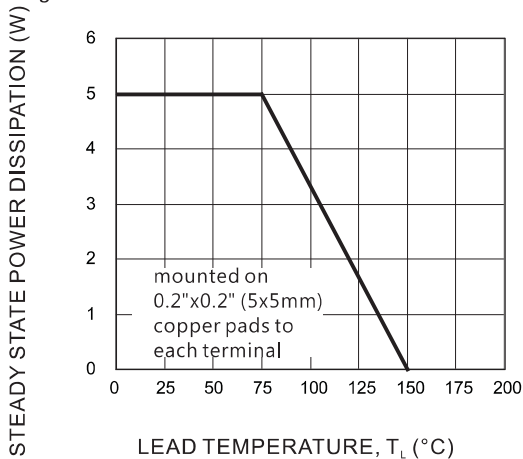
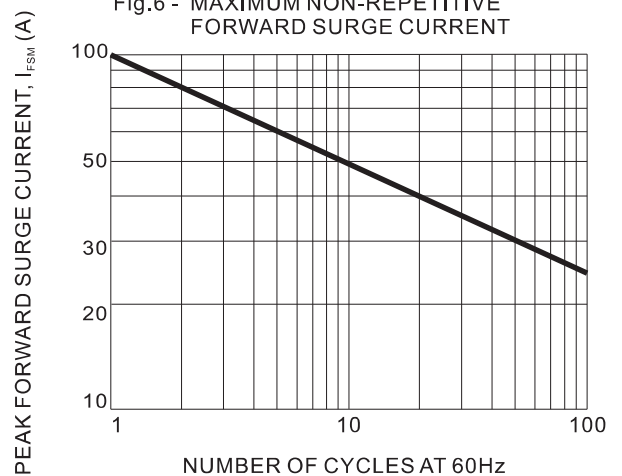





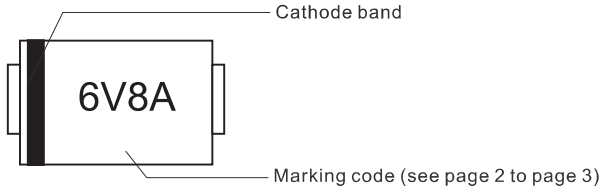

Fig.6 - MAXIMUM NON-REPETITIVE FORWARD SURGE CURRENT



Pinning information

Pin	Simplified outline	Symbol
Uni-Directional Pin1 cathode Pin2 anode		
Bi-Directional		

Marking

Type number	Example
Uni-Directional	
Bi-Directional	

Suggested solder pad layout

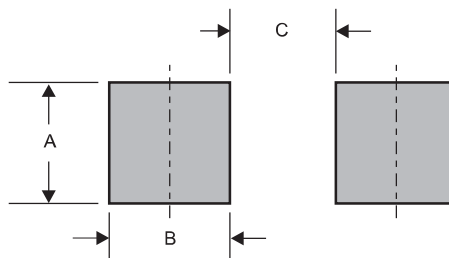

Dimensions in inches and (millimeters)

PACKAGE	A	B	C
SMB	0.078 (2.00)	0.059 (1.50)	0.110 (2.80)

X-ON Electronics

Largest Supplier of Electrical and Electronic Components

Click to view similar products for [ESD Suppressors / TVS Diodes](#) category:

Click to view products by [FUXINSEMI](#) manufacturer:

Other Similar products are found below :

[60KS200C](#) [D18V0L1B2LP-7B](#) [D5V0F4U5P5-7](#) [NTE4902](#) [P4KE27CA](#) [P6KE11CA](#) [P6KE8.2A](#) [SA60CA](#) [SA64CA](#) [SMBJ12CATR](#)
[SMBJ33CATR](#) [SMBJ6.5A](#) [SMBJ8.0A](#) [ESD101-B1-02ELS](#) [E6327](#) [ESD112-B1-02EL](#) [E6327](#) [ESD7451N2T5G](#) [19180-510](#) [CPDT-5V0USP-](#)
[HF](#) [3.0SMCJ33CA-F](#) [3.0SMCJ36A-F](#) [HSPC16701B02TP](#) [JANTX1N6126A](#) [D3V3Q1B2DLP3-7](#) [D55V0M1B2WS-7](#) [SCM1293A-04SO](#)
[ESD200-B1-CSP0201](#) [E6327](#) [SM12-7](#) [CEN955](#) [W/DATA](#) [VESD12A1A-HD1-GS08](#) [CPDQC5V0-HF](#) [D1213A-01LP4-7B](#) [ESD101-B1-02EL](#)
[E6327](#) [AOZ8808DI-03](#) [5KP15A](#) [5KP48A](#) [5KP90A](#) [ESD3V3D7-TP](#) [15KPA36A-LF](#) [P4KE56CA](#) [P4KE68A](#) [P4KE91CATR](#) [P6KE120A](#)
[P6KE13CA](#) [P6KE43CA](#) [P6KE6.8CA](#) [P6KE8.2](#) [P6SMBJ20CA](#) [JANTX1N6072A](#) [SR2835ESKG](#) [SA90CA](#)