

800nA I_Q, 300mA Low-Dropout Linear Regulator

Features

- Input voltage: 2.5V~6.5V
- Output range: 1.8V~3.6V (customized by every 0.1V step)
- Output current: 300mA @V_{IN} - V_{OUT} = 0.5V
- Dropout voltage: 180mV@I_{OUT} = 100mA
- Quiescent current: 0.8μA Typ.
- Recommend capacitor: 1μF

Applications

- Reference voltage source
- Toys
- Bluetooth, wireless handsets
- Low Consumption Device
- Others portable electronic device

General Description

The GS2301 series are low dropout linear regulators and optimized to provide a high performance solution for battery power system to delivery low quiescent current. The device offer a new level of cost effective performance in cellular phones, laptop and notebook computers, and other portable devices. GS2301 can provide output value in the range of 1.8V~3.6V by every 0.1V step.

The GS2301 series are designed to make use of low cost ceramic capacitors which ensure the stability of the output current, and enhance the efficiency in order to prolong the battery life of those portable devices.

The GS2301 regulators are available in UTDFN-1x1-4L, SOT23-5, SOT23-3 packages. Standard are products Pb-free and Halogen-free.

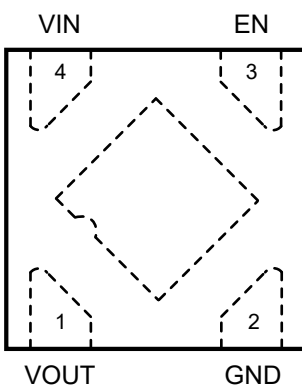

TDFN- 1x1-4L (Top View)

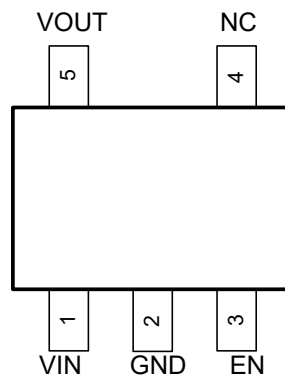
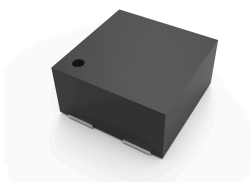

SOT-23-5 (Top View)

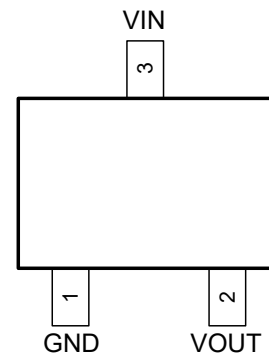
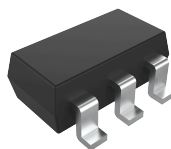

SOT-23-3 (Top View)



Ordering Information

Part Number	V _{OUT} (V)	Accuracy	Temperature	Package	Ordering Number	Packing Option
GS2301	XX	2%	-40 ~ +85°C	TDFN- 1x1-4L	GS2301-XXFR4	Tape and Real, 10000
GS2301	XX	2%	-40 ~ +85°C	SOT23-5	GS2301-XXTR5	Tape and Real, 3000
GS2301	XX	2%	-40 ~ +85°C	SOT23-3	GS2301-XXTR3	Tape and Real, 3000

Note: XX indicates 1.8V~3.6V by 0.1V step. For example, 33 means product outputs 3.3V.

Simplified Block Diagram

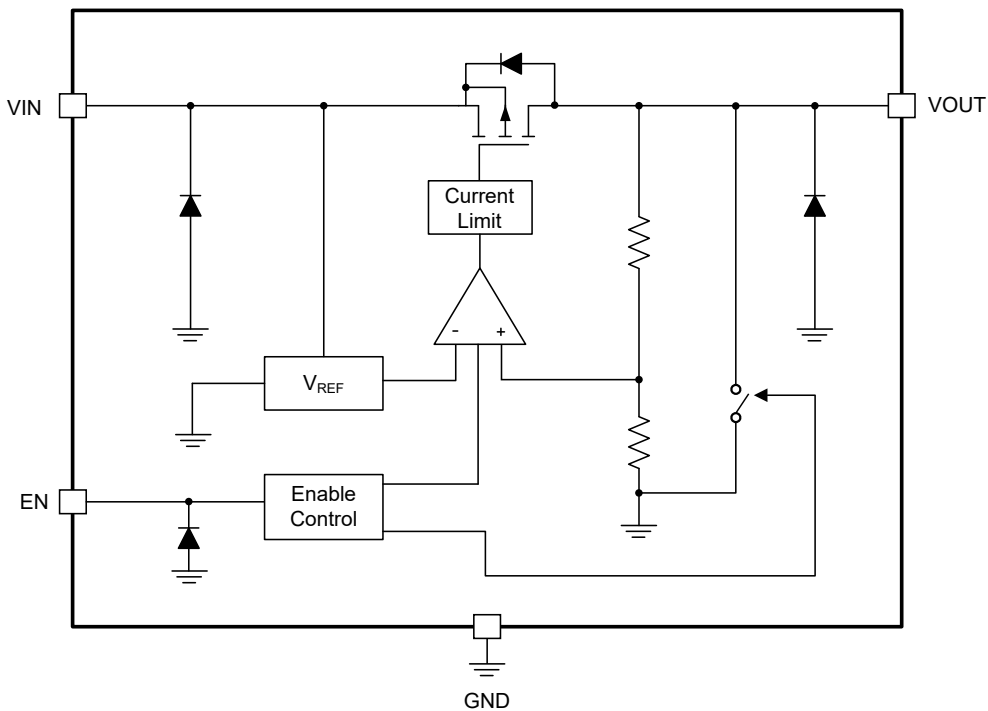

Application Circuit

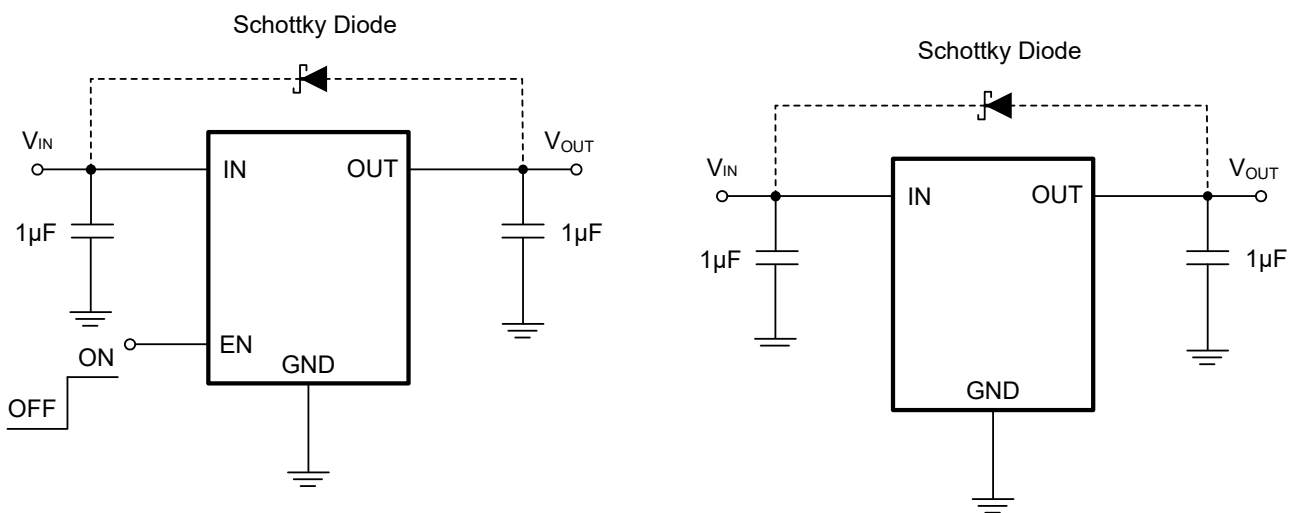

Specifications

Absolute Maximum Ratings

Parameter	Symbol	Value	Unit
Input Voltage	V_{IN}	-0.3~8	V
Output Current	I_{OUT}	350	mA
Power Dissipation	P_{DMAX}	0.6	W
Thermal Resistance	$R_{\theta JA}$	250	°C/W
Junction Temperature	T_J	-40~125	°C
Ambient Temperature	T_A	-40~85	°C
Storage Temperature	T_{STG}	-55~150	°C
Package Lead Soldering Temperature (10s)	T_{SOLDER}	260	°C

Note: Exceed these limits to damage to the device. Exposure to absolute maximum rating conditions may affect device reliability.

Recommended Operating Range

Parameter	Symbol	Value	Unit
Supply Voltage	V_{IN}	2.5~6.5	V
Operating Temperature	T_{OPT}	-40~85	°C

Electrical Characteristics

The following specifications apply for $V_{OUT} = 3.3V$, $T_A = 25^\circ C$, unless otherwise noted.

Parameter	Symbol	Conditions	Min	Typ	Max	Unit
Input Voltage	V_{IN}				6.5	V
Output Voltage	V_{OUT}	$I_{OUT} = 1mA$	-2	V_{OUT}	2	%
Quiescent Current	I_Q	$V_{OUT} = 3.3V, I_{OUT} = 0V$		1	2	μA
Current Limit	I_{LIMIT}	$V_{IN} - V_{OUT} = 0.5V$		350		mA
Dropout Voltage	V_{DROP}	$V_{OUT} = 3.3V, I_{OUT} = 100mA$		0.18		V
		$V_{OUT} = 3.3V, I_{OUT} = 200mA$		0.36		V
Line Regulation	ΔV_{LINE}	$V_{IN} = 2.7\sim 5.5V, I_{OUT} = 1mA$		0.01		%/V
Load Regulation	ΔV_{LOAD}	$V_{OUT} = 3.3V,$ $I_{OUT} = 1\sim 300mA$		100		mV
Short Current	I_{SHORT}	$V_{EN} = V_{IN},$ V_{OUT} Short to GND with 1Ω		70		mA
Shutdown Current	I_{SHDN}	$V_{EN} = 0V$		0.1	1	μA
EN Logic High Voltage	V_{ENH}	$V_{IN} = 5.5V, I_{OUT} = 1mA$	1.2		V_{IN}	V
EN Logic Low Voltage	V_{ENL}	$V_{IN} = 5.5V, V_{OUT} = 0V$			0.4	V
EN Input Current	I_{EN}	$V_{EN} = 0$ to $5.5V$			1.0	μA

Performance Characteristics

$C_{IN}=1\mu F, C_{OUT}=1\mu F, T_A=25^\circ C, V_{IN}=3.8V, V_{OUT}=3.3V$, unless otherwise noted.

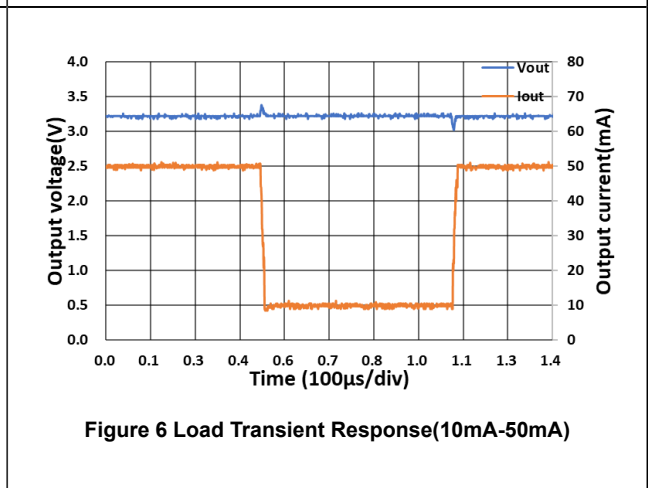
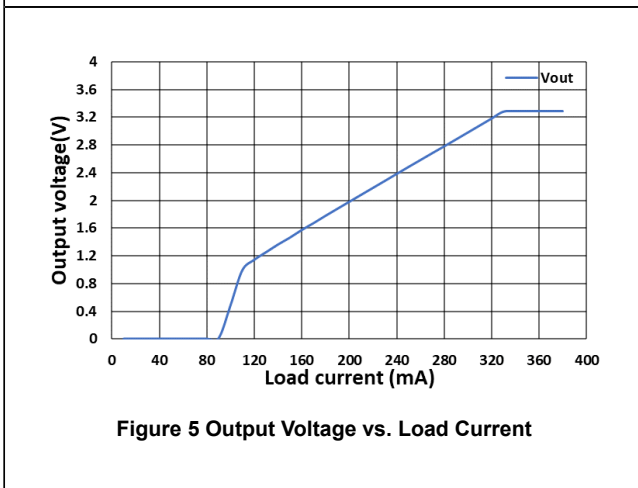
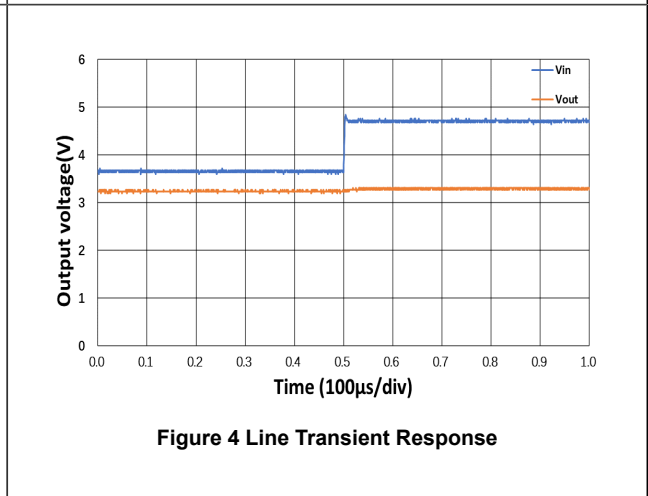
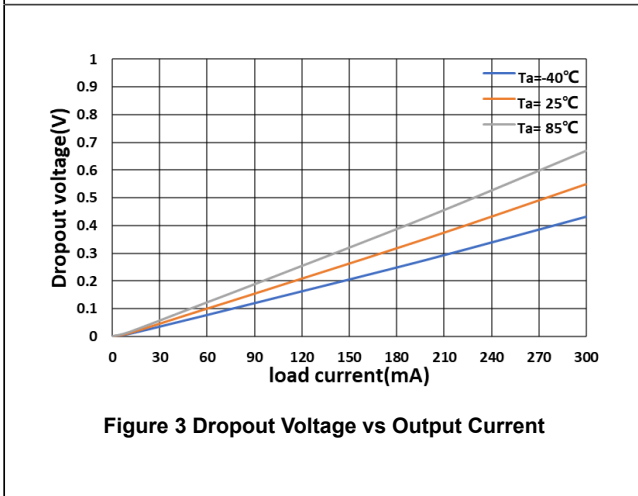
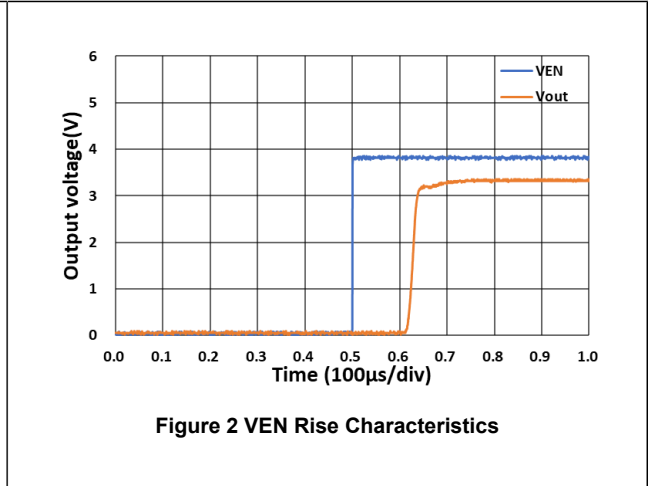
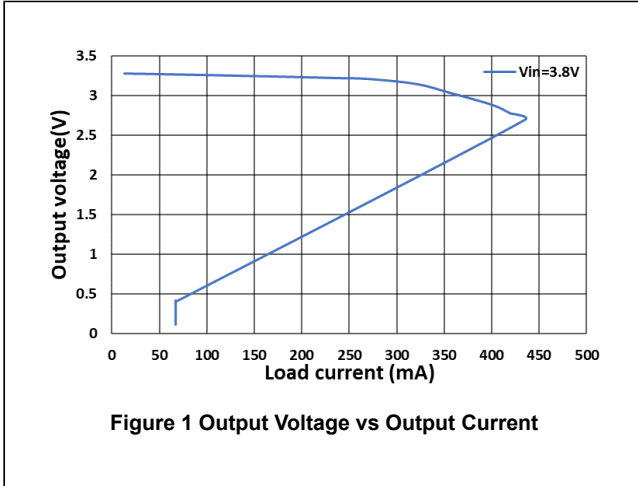

Performance Characteristics(Continued)

$C_{IN}=1\mu F$, $C_{OUT}=1\mu F$, $T_A=25^\circ C$, $V_{IN}=3.8V$, $V_{OUT}=3.3V$, unless otherwise noted.

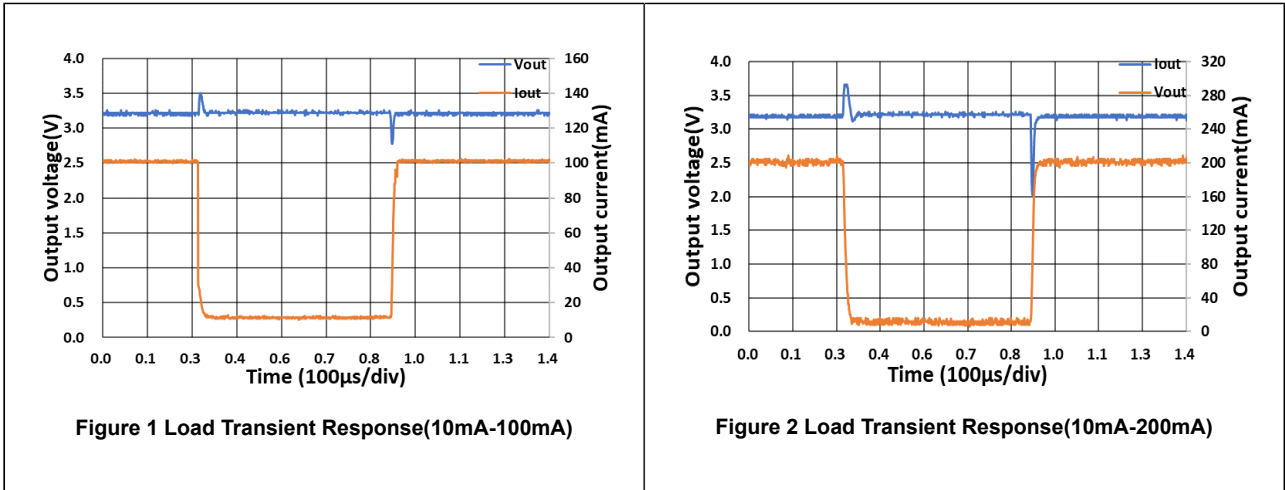

Package Outline

TDFN-1x1-4L

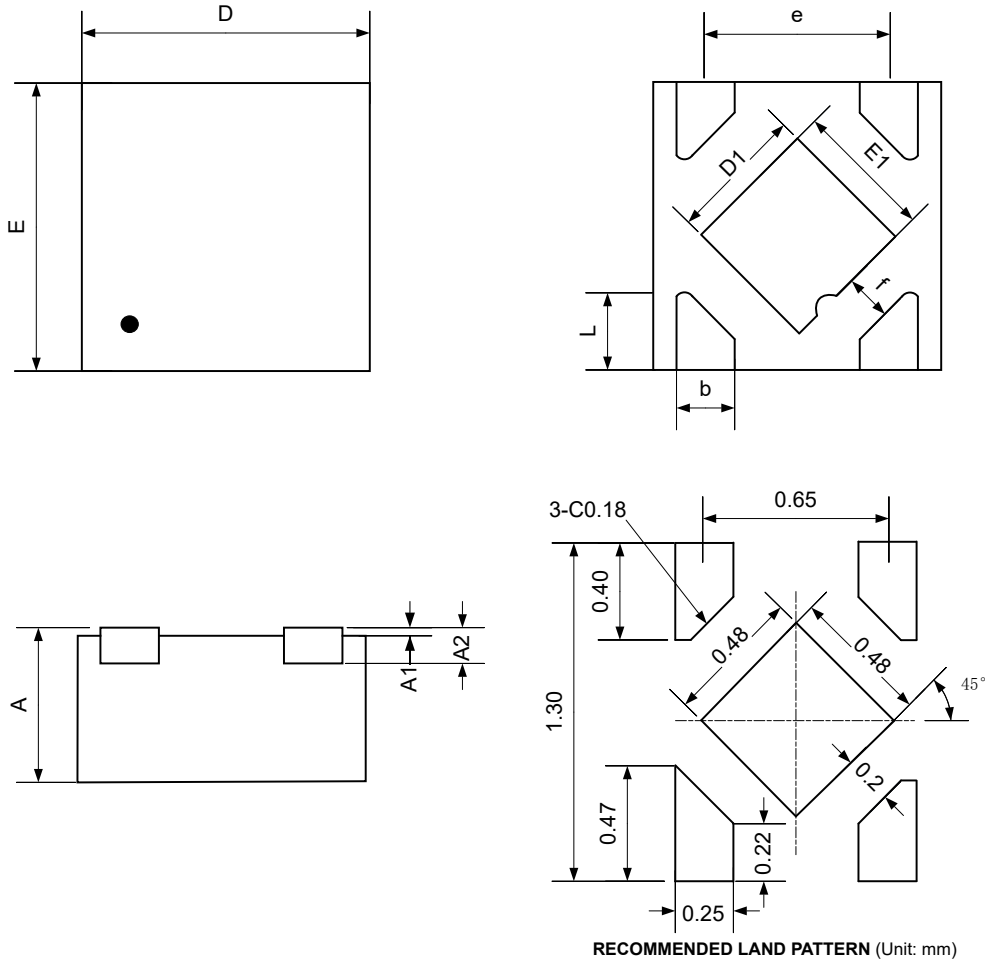

Symbol	Dimensions in Millimeters		
	Min	Nominal	Max
A	0.500	0.550	0.600
A1	0.000		0.050
A2	0.152 REF		
D	0.950	1.000	1.050
D1	0.450	0.500	0.550
E	0.950	1.000	1.050
E1	0.450	0.500	0.550
b	0.175	0.225	0.275
e	0.625 BSC		
f	0.195 REF		
L	0.200	0.250	0.300

SOT23-5

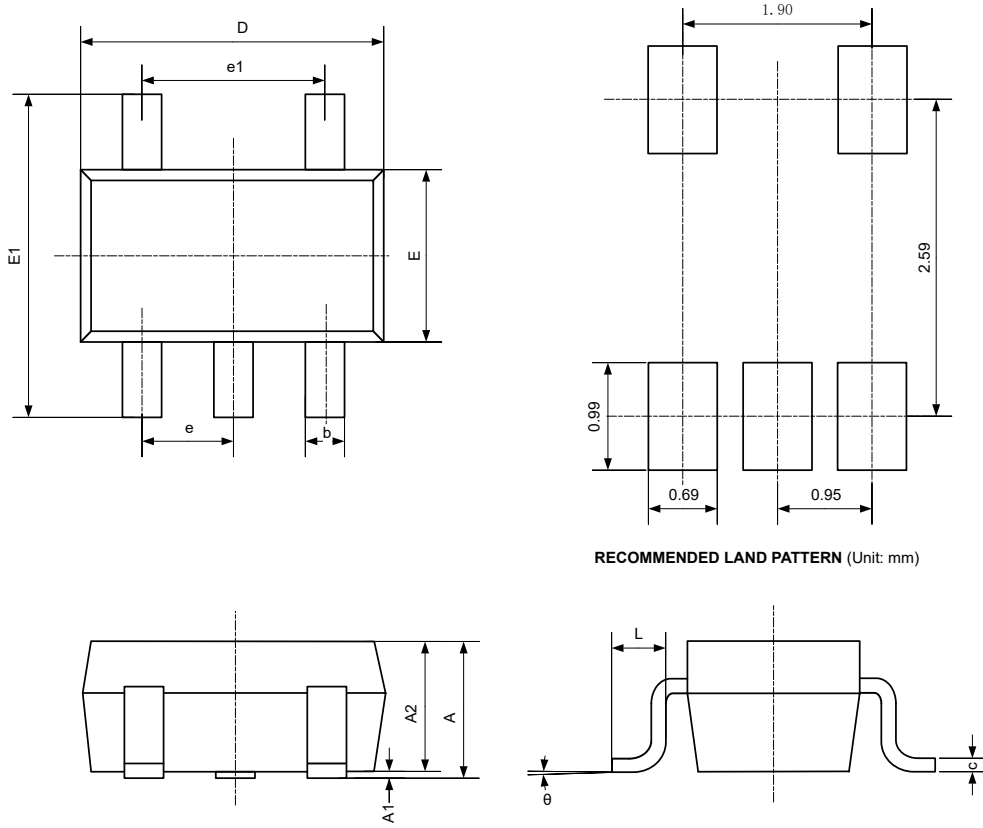

Symbol	Dimensions in Millimeters		Dimensions in Inches	
	Min	Max	Min	Max
A	1.050	1.250	0.041	0.049
A1	0.000	0.100	0.000	0.004
A2	1.050	1.150	0.041	0.045
b	0.300	0.500	0.012	0.020
c	0.100	0.200	0.004	0.008
D	2.820	3.020	0.111	0.119
E	1.500	1.700	0.059	0.067
E1	2.650	2.950	0.104	0.116
e	0.950 BSC		0.037 BSC	
e1	1.900 BSC		0.075 BSC	
L	0.300	0.600	0.012	0.024
θ	0°	8°	0°	8°

SOT23-3

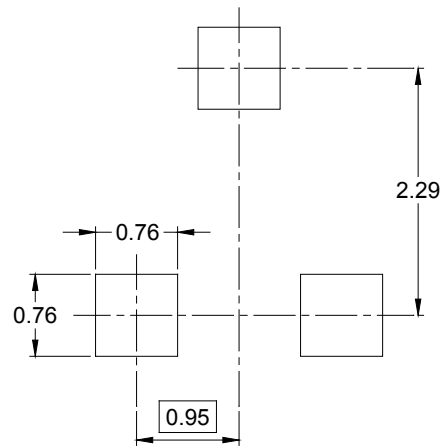
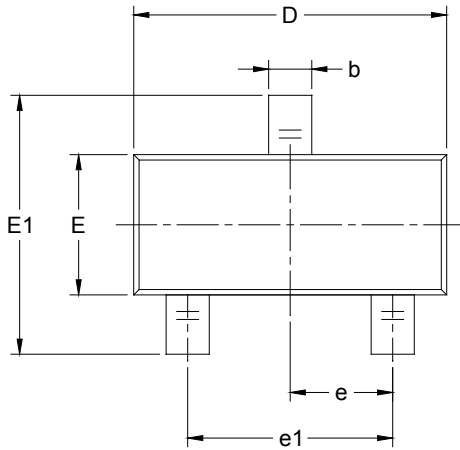

RECOMMENDED LAND PATTERN (Unit: mm)

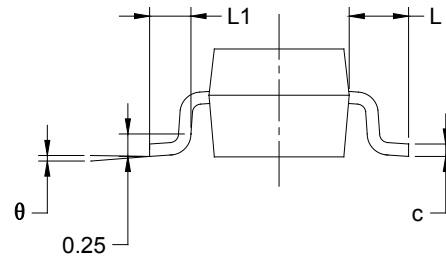
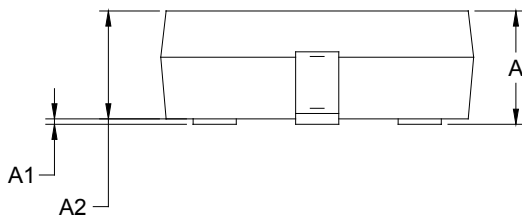

Symbol	Dimensions In Millimeters		Dimensions In Inches	
	MIN	MAX	MIN	MAX
A	0.900	1.150	0.035	0.045
A1	0.000	0.100	0.000	0.004
A2	0.900	1.050	0.035	0.041
b	0.300	0.500	0.012	0.020
c	0.080	0.150	0.003	0.006
D	2.800	3.000	0.110	0.118
E	1.200	1.400	0.047	0.055
E1	2.250	2.550	0.089	0.100
e	0.950 BSC		0.037 BSC	
e1	1.900 BSC		0.075 BSC	
L	0.550 REF		0.022 REF	
L1	0.300	0.500	0.012	0.020
θ	0°	8°	0°	8°

X-ON Electronics

Largest Supplier of Electrical and Electronic Components

Click to view similar products for [Linear Voltage Regulators](#) category:

Click to view products by [Gainsil](#) manufacturer:

Other Similar products are found below :

[LV5684PVD-XH](#) [MCDTSA6-2R](#) [L7815ACV-DG](#) [714954EB](#) [ZMR500QFTA](#) [BA033LBSG2-TR](#) [LV5680P-E](#) [L79M05T-E](#) [L78LR05D-MA-E](#) [NCV317MBTG](#) [NTE7227](#) [MP2018GZD-33-P](#) [MP2018GZD-5-P](#) [LV5680NPVC-XH](#) [LT1054CN8](#) [ZTS6538SE](#) [UA78L09CLP](#) [UA78L09CLPR](#) [CAT6221-PPTD-GT3](#) [MC78M09CDTRK](#) [NCV51190MNTAG](#) [78M05](#) [HT7150-1](#) [UM1540DB-18](#) [XC6234H281VR-G](#) [WL2834CA-6/TR](#) [TPL730F33-5TR](#) [TLS850F1TA](#) [V50](#) [TPS549B22RVFR](#) [UM1540DB-33](#) [WL9200P3-50B](#) [WL9100P3-33B](#) [WL9005D4-33](#) [XC6219B152MR](#) [WL2855K33-3/TR](#) [PJ54BM33SE](#) [PJ9500M25SA](#) [MD7218E33PC1](#) [H7533-2PR](#) [SK7812AU](#) [SD1A30](#) [78L33](#) [TP78L33T3](#) [L78L33ACUTR](#) [SK6513ST3A-50](#) [SK6054D4-09](#) [SK6054D4-18](#) [SK6054D4-11](#) [SK6054D4-10](#) [LM79L12F](#)