

Features

- **Single-Supply Operation from +3V ~ +36V**
- **Dual-Supply Operation from $\pm 1.5V \sim \pm 18V$**
- **Gain-Bandwidth Product: 1MHz (Typ)**
- **Low Input Bias Current: 20nA (Typ)**
- **Low Offset Voltage: 5mV (Max)**
- **Quiescent Current: GS2904 500 μ A/ GS2902 700 μ A**
- **Input Common Mode Voltage Range Includes**

- **Large Output Voltage Swing: 0V to $V_{CC}-1.5V$**
- **Operating Temperature: $-40^{\circ}C \sim +125^{\circ}C$**
- **Small Package:**

GS2904 Available in SOP-8 and MSOP-8 Packages

GS2902 Available in SOP-14 and TSSOP-14 Packages

Ground

General Description

The GS2902/GS2904 series amplifiers consist of four and two independent high-gain operational amplifiers with very low input offset voltage specification. They have been designed to operate from a single power supply over a wide range of voltages; however operation from split power supplies is also possible. They offer low power supply current independent of the magnitude of the power supply voltage. The GS2902/GS2904 series are characterized for operation from $-40^{\circ}C$ to $+125^{\circ}C$ and the dual devices are available in SO-8, MSOP-8 and the quad devices available in SO-14 and TSSOP-14 with industry standard pin-outs. Both use green mold compound as standard.

Applications

- Walkie-Talkie
- Battery Management Solution
- Transducer Amplifiers
- Summing Amplifiers
- Multivibrators
- Oscillators
- Switching Telephone
- Portable Systems

Pin Configuration

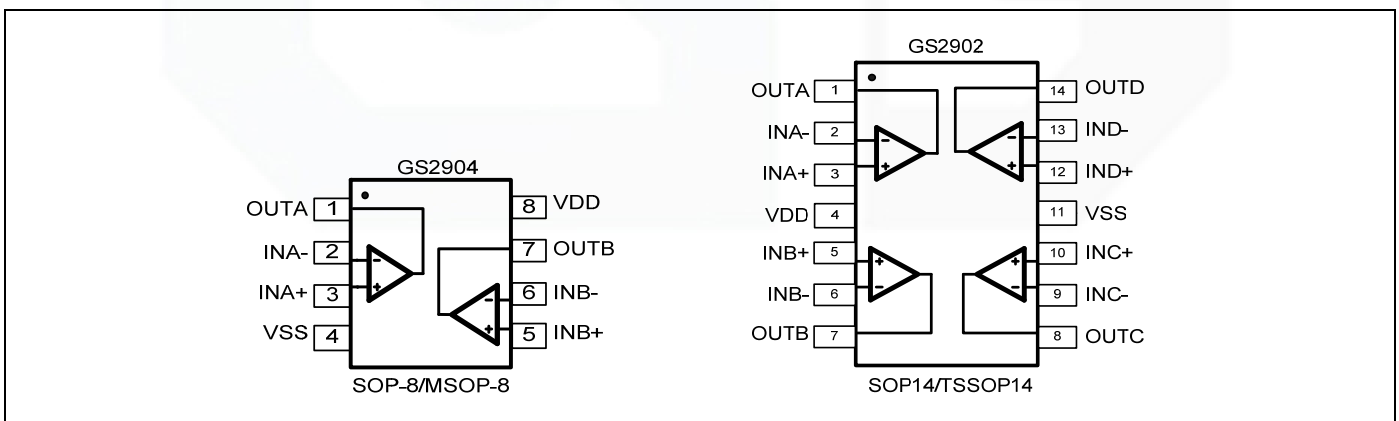

Figure 1. Pin Assignment Diagram

Absolute Maximum Ratings

Condition	Symbol	Max
Power Supply Voltage	V _{cc}	± 18V or 36V
Differential input voltage	V _{I(DIFF)}	36V
Input Voltage	V _I	-0.3V~36V
Operating Temperature Range	T _{opr}	-40°C ~+125°C
Storage Temperature Range	T _{stg}	-65°C ~+150°C

Note: Stress greater than those listed under Absolute Maximum Ratings may cause permanent damage to the device. This is a stress rating only and functional operation of the device at these or any other conditions outside those indicated in the operational sections of this specification are not implied. Exposure to absolute maximum rating conditions for extended periods may affect reliability.

Package/Ordering Information

MODEL	CHANNEL	ORDER NUMBER	PACKAGE DESCRIPTION	PACKAGE OPTION	MARKING INFORMATION
GS2904	Dual	GS2904-SR	SOP-8	Tape and Reel,4000	GS2904
		GS2904-MR	MSOP-8	Tape and Reel,3000	GS2904
GS2902	Quad	GS2902-SR	SOP-14	Tape and Reel,2500	GS2902
		GS2902-TR	TSSOP-14	Tape and Reel,3000	GS2902

Electrical Characteristics

 (At $V_S = +15V$, $T_A = 25^\circ C$, unless otherwise noted.)

PARAMETER	SYMBOL	CONDITIONS	GS2902/GS2904			
			TYP	MIN/MAX OVER TEMPERATURE		
			+25°C	+25°C	UNITS	MIN/MAX
INPUT CHARACTERISTICS						
Input Offset Voltage	V_{OS}	$V_{CM} = V_S/2$	0.4	5	mV	MAX
Input Bias Current	I_B		20		nA	TYP
Input Offset Current	I_{OS}		5		nA	TYP
Common-Mode Voltage Range	V_{CM}	$V_S = 30V$	-0.1 to $V_{CC}-1.5$		V	TYP
Common-Mode Rejection Ratio	CMRR	$V_{CM} = 0V$ to $V_S-1.5V$	70	60	dB	MIN
Open-Loop Voltage Gain	A_{OL}	$R_L = 5k\Omega$, $V_O = 1V$ to $11V$	100	85	dB	MIN
Input Offset Voltage Drift	$\Delta V_{OS}/\Delta T$	$R_S = 0\Omega$	7		$\mu V/^\circ C$	TYP
OUTPUT CHARACTERISTICS						
Output Voltage Swing from Rail	V_{OH}	$R_L = 2k\Omega$	11		V	MIN
	V_{OL}	$R_L = 2k\Omega$	5	20	mV	MAX
	V_{OH}	$R_L = 10k\Omega$	12	13	V	MIN
	V_{OL}	$R_L = 10k\Omega$	5	20	mV	MAX
Output Current	I_{SOURCE}	$R_L = 10\Omega$ to $V_S/2$	40	60	mA	MAX
	I_{SINK}		40	60		
POWER SUPPLY						
Operating Voltage Range				3	V	MIN
				36	V	MAX
Power Supply Rejection Ratio	PSRR	$V_S = +5V$ to $+36V$, $V_{CM} = +0.5V$	100	70	dB	MIN
Quiescent Current / Amplifier	I_Q	$V_S = 36V$, $R_L = \infty$	1	3.0	mA	MAX
DYNAMIC PERFORMANCE						
Gain-Bandwidth Product	GBP		1		MHz	TYP
Slew Rate	SR	$G = +1$, 2V Output Step	0.2		V/ μs	TYP

Typical Performance characteristics

Input Voltage Range

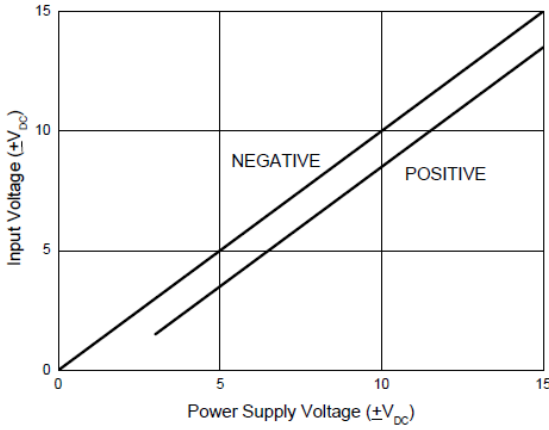

Input Current

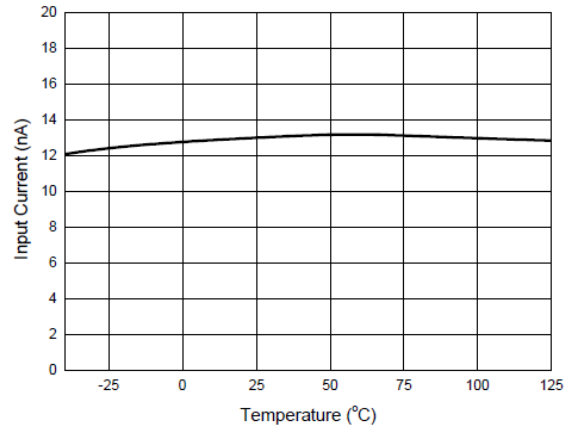

Supply Current

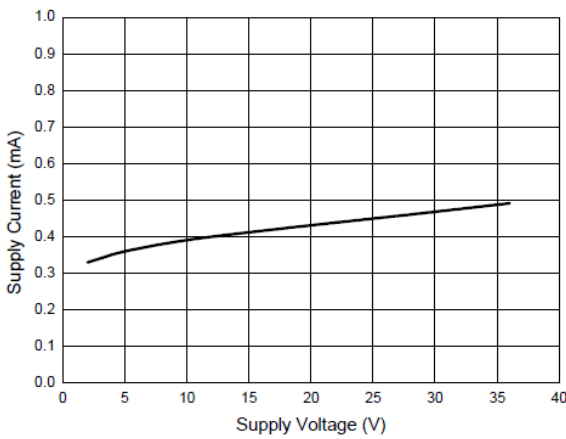

Voltage Gain

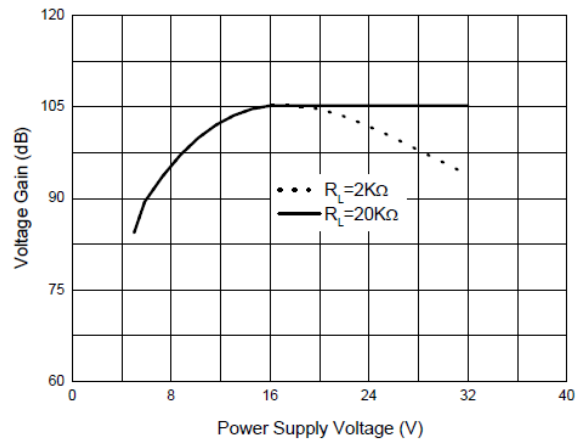

Open Loop Frequency Response

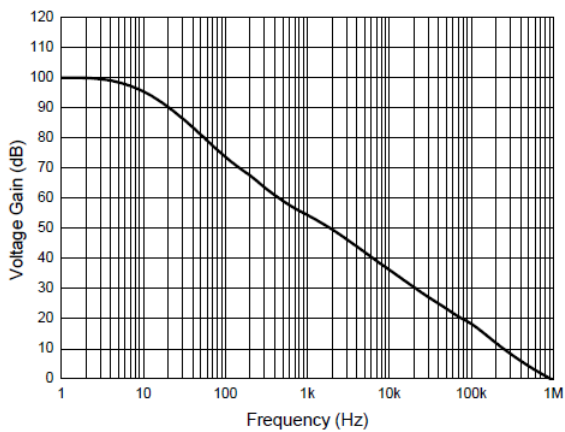

Voltage Follower Pulse Response

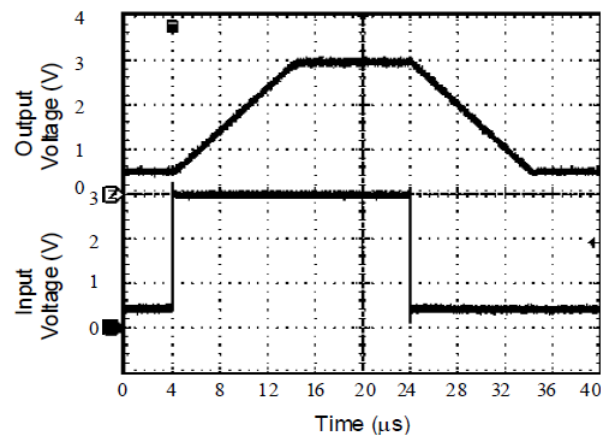

Typical Performance characteristics

Voltage Follower Pulse Response (Small Signal)

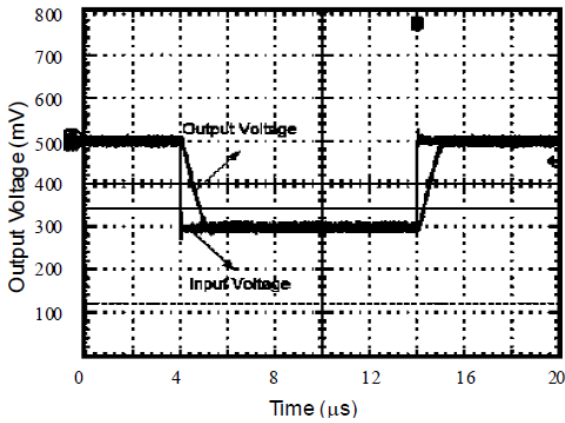

Large Signal Frequency Response

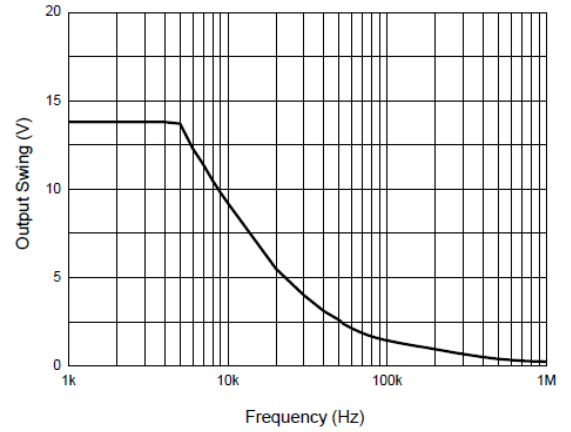

Output Characteristics: Current Sourcing

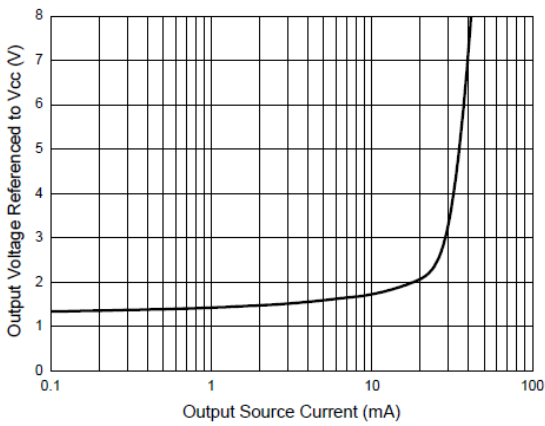

Output Characteristics: Current Sinking

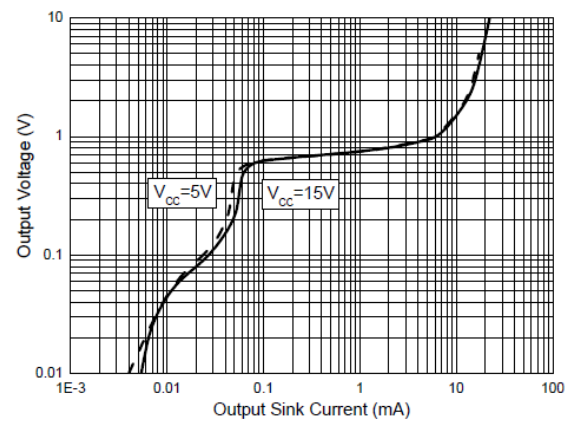

Current Limiting

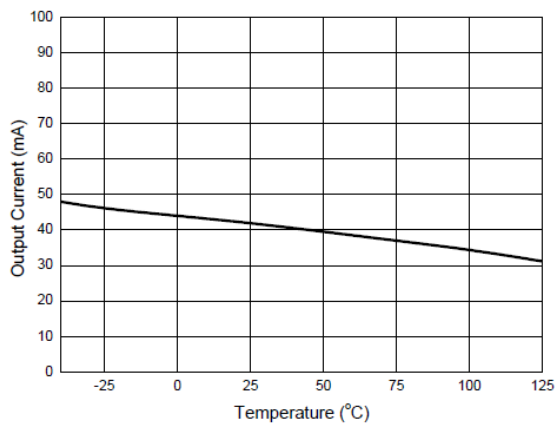

Package Information

SOP-8

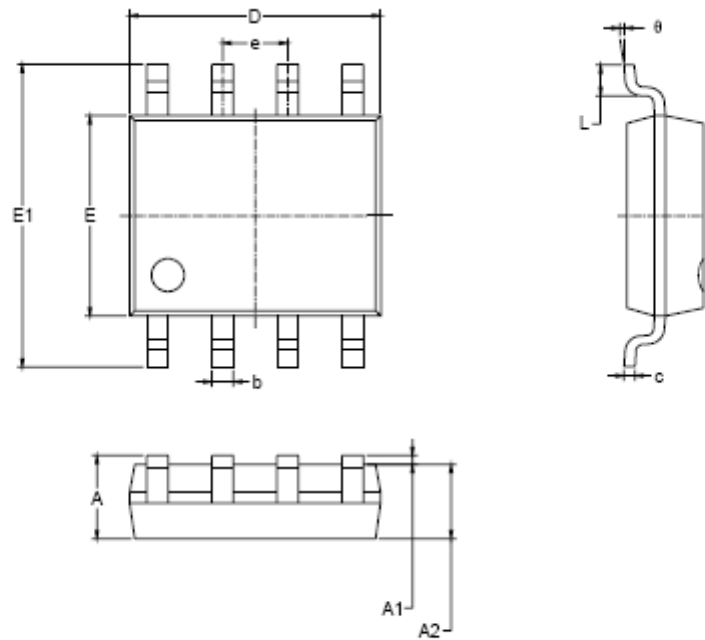

Symbol	Dimensions In Millimeters		Dimensions In Inches	
	MIN	MAX	MIN	MAX
A	1.350	1.750	0.053	0.069
A1	0.100	0.250	0.004	0.010
A2	1.350	1.550	0.053	0.061
b	0.330	0.510	0.013	0.020
c	0.170	0.250	0.006	0.010
D	4.700	5.100	0.185	0.200
E	3.800	4.000	0.150	0.157
E1	5.800	6.200	0.228	0.244
e	1.27 BSC		0.050 BSC	
L	0.400	1.270	0.016	0.050
θ	0°	8°	0°	8°

MSOP-8

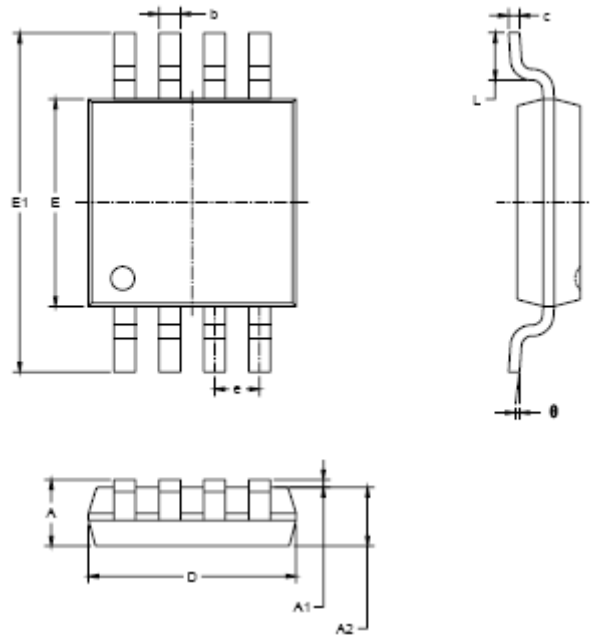

Symbol	Dimensions In Millimeters		Dimensions In Inches	
	MIN	MAX	MIN	MAX
A	0.820	1.100	0.032	0.043
A1	0.020	0.150	0.001	0.006
A2	0.750	0.950	0.030	0.037
b	0.250	0.380	0.010	0.015
c	0.090	0.230	0.004	0.009
D	2.900	3.100	0.114	0.122
E	2.900	3.100	0.114	0.122
E1	4.750	5.050	0.187	0.199
e	0.650 BSC		0.026 BSC	
L	0.400	0.800	0.016	0.031
θ	0°	6°	0°	6°

SOP-14

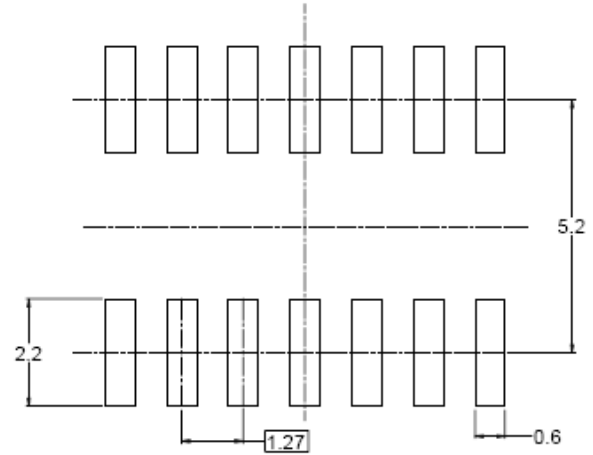
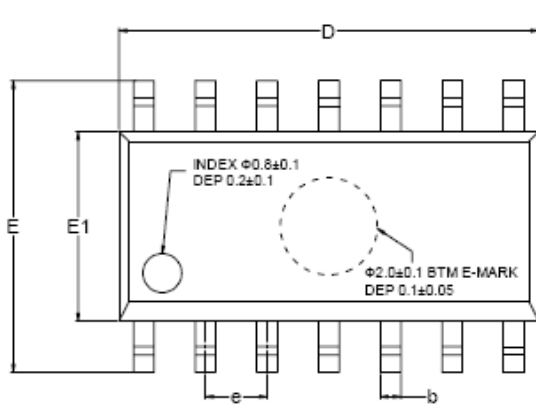

RECOMMENDED LAND PATTERN (Unit: mm)

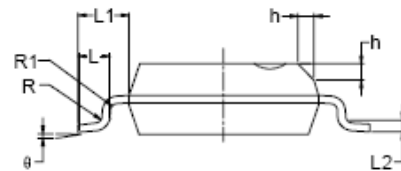
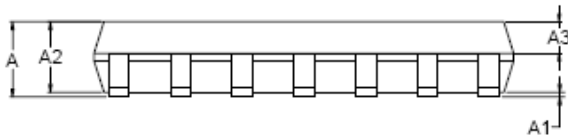

Symbol	Dimensions In Millimeters			Dimensions In Inches		
	MIN	MOD	MAX	MIN	MOD	MAX
A	1.35		1.75	0.053		0.069
A1	0.10		0.25	0.004		0.010
A2	1.25		1.65	0.049		0.065
A3	0.55		0.75	0.022		0.030
b	0.36		0.49	0.014		0.019
D	8.53		8.73	0.336		0.344
E	5.80		6.20	0.228		0.244
E1	3.80		4.00	0.150		0.157
e	1.27 BSC			0.050 BSC		
L	0.45		0.80	0.018		0.032
L1	1.04 REF			0.040 REF		
L2	0.25 BSC			0.01 BSC		
R	0.07			0.003		
R1	0.07			0.003		
h	0.30		0.50	0.012		0.020
θ	0°		8°	0°		8°

TSSOP14

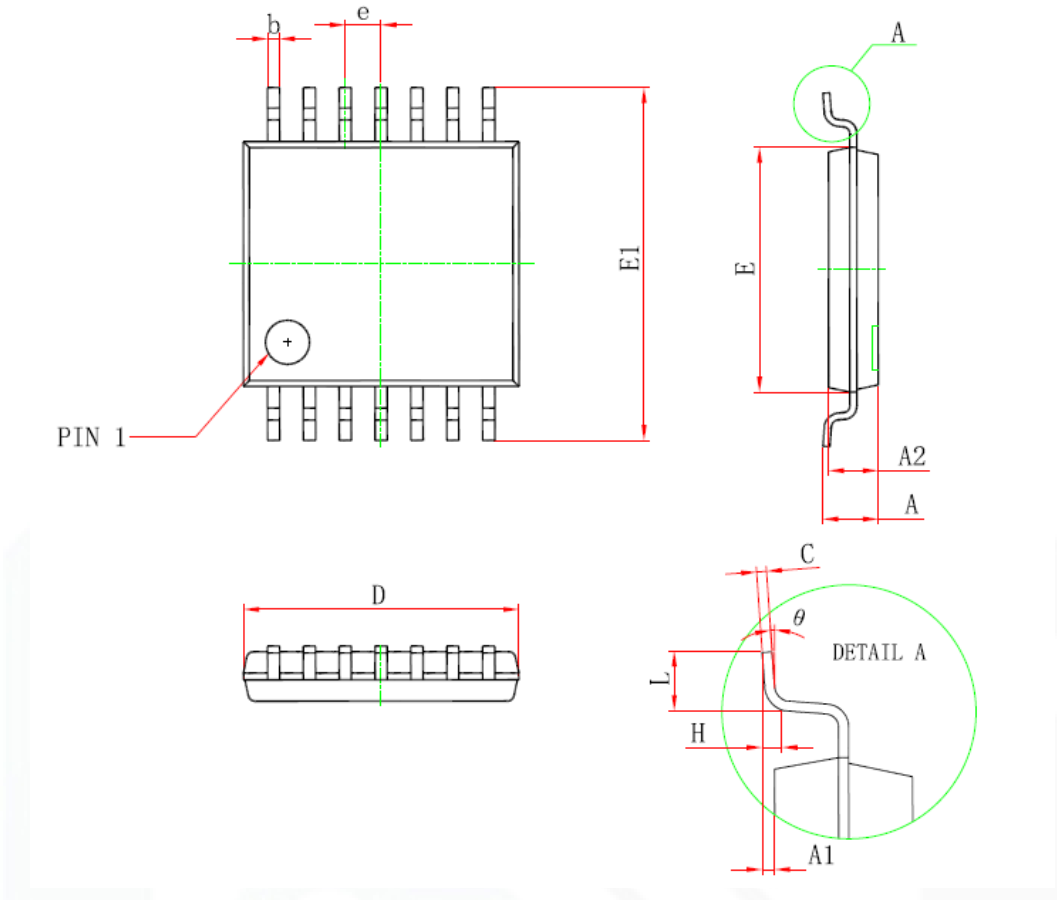

Symbol	Dimensions In Millimeters		Dimensions In Inches	
	Min	Max	Min	Max
D	4.900	5.100	0.193	0.201
E	4.300	4.500	0.169	0.177
b	0.190	0.300	0.007	0.012
c	0.090	0.200	0.004	0.008
E1	6.250	6.550	0.246	0.258
A		1.200		0.047
A2	0.800	1.000	0.031	0.039
A1	0.050	0.150	0.002	0.006
e	0.65 (BSC)		0.026 (BSC)	
L	0.500	0.700	0.020	0.028
H	0.25(TYP)		0.01(TYP)	
θ	1°	7°	1°	7°

X-ON Electronics

Largest Supplier of Electrical and Electronic Components

Click to view similar products for [Operational Amplifiers - Op Amps](#) category:

Click to view products by [Gainsil](#) manufacturer:

Other Similar products are found below :

[430227FB](#) [LT1678IS8](#) [NCV33202DMR2G](#) [NJM324E](#) [M38510/13101BPA](#) [NTE925](#) [AZV358MTR-G1](#) [AP4310AUMTR-AG1](#)
[AZV358MMTR-G1](#) [SCY33178DR2G](#) [NCV20034DR2G](#) [NTE778S](#) [NTE871](#) [NTE937](#) [NJU7057RB1-TE2](#) [SCY6358ADR2G](#)
[NJM2904CRB1-TE1](#) [UPC4570G2-E1-A](#) [UPC4741G2-E1-A](#) [NJM8532RB1-TE1](#) [EL2250CS](#) [EL5100IS](#) [EL5104IS](#) [EL5127CY](#) [EL5127CYZ](#)
[EL5133IW](#) [EL5152IS](#) [EL5156IS](#) [EL5162IS](#) [EL5202IY](#) [EL5203IY](#) [EL5204IY](#) [EL5210CS](#) [EL5210CYZ](#) [EL5211IYE](#) [EL5220CY](#)
[EL5223CLZ](#) [EL5223CR](#) [EL5224ILZ](#) [EL5227CLZ](#) [EL5227CRZ](#) [EL5244CS](#) [EL5246CS](#) [EL5246CSZ](#) [EL5250IY](#) [EL5251IS](#) [EL5257IS](#)
[EL5260IY](#) [EL5261IS](#) [EL5300IU](#)