

### Features

- On-Resistance: 2.5Ω (TYP)
- -3dB Bandwidth: 120MHz
- Single-Supply Operation: +1.8V ~ +5.5V
- Break-Before-Make Switching
- Rail-to-Rail Operation
- Low Static Power
- TTL/CMOS Compatible
- Operating Temperature: -40°C ~ +125°C
- Small Package:  
GS3101 Available in SOT23-6 and SC70-6 Packages

### General Description

The GS3101 is low on-resistance (2.5Ω), fast single-pole double-throw (SPDT) CMOS switch with operation range +1.8V ~ +5.5V. The GS3101 is designed for low operating voltage, high current switching of signal gating, chopping, modulation or demodulation (modem), and speaker output for cell phone applications.

The device contains a break-before-make (BBM) feature. The control input, IN, tolerates input drive signals up to 5.5V, independent of supply voltage.

All devices are specified for the temperature range of -40°C to +125°C. The GS3101 single is available in Green SC70-6 and SOT23-6 packages.

### Applications

- Battery-Operated Equipment
- Wearable Devices
- Computer Peripherals
- Portable Systems
- Cell Phones
- PDAs

### Pin Configuration

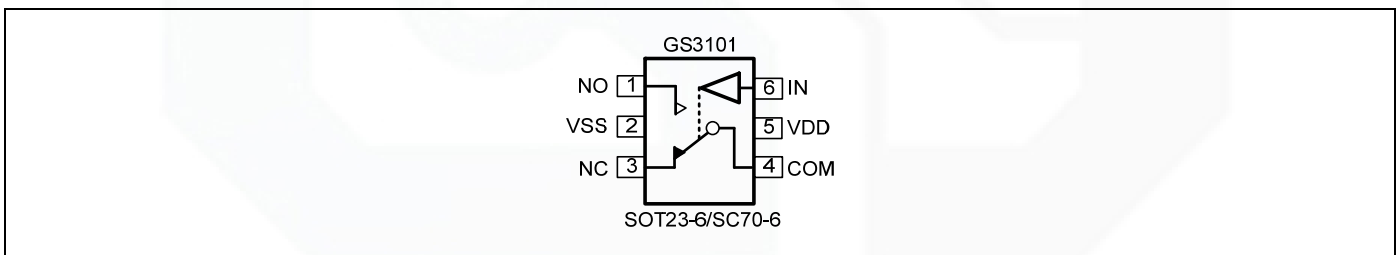

Figure 1. Pin Assignment Diagram

## Absolute Maximum Ratings

Condition	Min	Max
Power Supply Voltage ( $V_{DD}$ to $V_{SS}$ )	-0.5V	+7.5V
Analog Input Voltage (NC NO or COM)	$V_{SS}-0.5V$	$V_{DD}+0.5V$
PDB Input Voltage	$V_{SS}-0.5V$	+7V
Operating Temperature Range	-40°C	+125°C
Junction Temperature	+160°C	
Storage Temperature Range	-55°C	+150°C
Lead Temperature (soldering, 10sec)	+260°C	
<b>Package Thermal Resistance (<math>T_A=+25^\circ\text{C}</math>)</b>		
SOT23-6, $\theta_{JA}$	190°C/W	
SC70-6, $\theta_{JA}$	333°C/W	
<b>ESD Susceptibility</b>		
HBM	3500V	
MM	300V	

**Note:** Stress greater than those listed under Absolute Maximum Ratings may cause permanent damage to the device. This is a stress rating only and functional operation of the device at these or any other conditions outside those indicated in the operational sections of this specification are not implied. Exposure to absolute maximum rating conditions for extended periods may affect reliability.

**Package/Ordering Information**

MODEL	CHANNEL	ORDER NUMBER	PACKAGE DESCRIPTION	PACKAGE OPTION	MARKING INFORMATION
GS3101	Single	GS3101-CR	SC70-6	Tape and Reel,3000	3101
		GS3101-TR	SOT23-6	Tape and Reel,3000	3101



## Electrical Characteristics

(At  $V_S = +5V$ , and  $T_A = +25^\circ C$ , unless otherwise noted.)

PARAMETER	SYMBOL	CONDITIONS					
			25°C	-40°C ~85°C	-40°C ~125°C	LIMIT	UNITS
<b>ANALOG SWITCH</b>							
Analog Signal Range	$V_{NO}, V_{NC}, V_{COM}$		$V_S$	$V_S$	$V_S$	MAX	V
On-Resistance	$R_{ON}$	$V_S = 5V, V_{NO}$ or $V_{NC} = 4V,$ $I_{COM} = -10mA$ , Test Circuit 1	2.5			TYP	$\Omega$
On-Resistance Match Between Channels	$\Delta R_{ON}$	$V_S = 5V, V_{NO}$ or $V_{NC} = 4V,$ $I_{COM} = -10mA$ , Test Circuit 1	0.1			TYP	$\Omega$
		$V_S = 5V, V_{NO}$ or $V_{NC} = 4V,$ $I_{COM} = -10mA$ , Test Circuit 1	0.9			MAX	$\Omega$
On-Resistance Flatness	$R_{FLAT(ON)}$	$V_S = 4.5V, V_{NO}$ or $V_{NC} = 1.0V, 2.0V,$ 3.5V, $I_{COM} = -10mA$ , Test Circuit 1	0.7			TYP	$\Omega$
		$V_S = 4.5V, V_{NO}$ or $V_{NC} = 1.0V, 2.0V,$ 3.5V, $I_{COM} = -10mA$ , Test Circuit 1	1.0			MAX	$\Omega$
Source OFF Leakage Current	$I_{NC(OFF)}, I_{NO(OFF)}$	$V_S = 5.5V, V_{NO}$ or $V_{NC} = 1.0V, 4.5V,$ $V_{COM} = 4.5V, 1.0V$	$\pm 1$			MAX	$\mu A$
Channel ON Leakage Current	$I_{NC(ON)}, I_{NO(ON)}, I_{COM(ON)}$	$V_S = 5.5V, V_{COM} = 1.0V, 4.5V$ $V_{NO}$ or $V_{NC} = 1.0V, 4.5V$ , or floating	$\pm 1$			MAX	$\mu A$
<b>DIGITAL INPUTS</b>							
Input High Voltage	$V_{INH}$	$V_S = 5V$	1.5			MIN	V
		$V_S = 3V$	0.9			MIN	V
Input Low Voltage	$V_{INL}$	$V_S = 5V$	0.55			MAX	V
		$V_S = 3V$	0.45			MAX	V
Input Leakage Current	$I_{IN}$	$V_S = 5.5V, V_{IN} = 0V$ or $5.5V$	$\pm 1$			MAX	$\mu A$

(At  $V_S = +5V$ , and  $T_A = +25^\circ C$ , unless otherwise noted.)

PARAMETER	SYMBOL	CONDITIONS					
			25°C	-40°C ~85°C	-40°C ~125°C	LIMIT	UNITS
<b>DYNAMIC CHARACTERISTICS</b>							
Turn-On Time	$T_{ON}$	$V_S = 5V, V_{NO}$ or $V_{NC} = 3V, V_{IN\_H} = 1.5V, V_{IN\_L} = 0V,$ $R_L = 300\Omega, C_L = 35pF,$ Test Circuit 2	20			TYP	ns
		$V_S = 3V, V_{NO}$ or $V_{NC} = 1.5V, V_{IN\_H} = 1.5V, V_{IN\_L} = 0V,$ $R_L = 300\Omega, C_L = 35pF,$ Test Circuit 2	28			TYP	ns
Turn-Off Time	$T_{OFF}$	$V_S = 5V, V_{NO}$ or $V_{NC} = 3V, V_{IN\_H} = 1.5V, V_{IN\_L} = 0V,$ $R_L = 300\Omega, C_L = 35pF,$ Test Circuit 2	23			TYP	ns
		$V_S = 3V, V_{NO}$ or $V_{NC} = 1.5V, V_{IN\_H} = 1.5V, V_{IN\_L} = 0V,$ $R_L = 300\Omega, C_L = 35pF,$ Test Circuit 2	22			TYP	ns
Break-Before-Make Time Delay	$T_{BBM}$	$V_S = 5V, V_{NO1}$ or $V_{NC1} = V_{NO2}$ or $V_{NC2} = 3V,$ $R_L = 300\Omega, C_L = 35pF,$ Test Circuit 3	10			TYP	ns
		$V_S = 3V, V_{NO1}$ or $V_{NC1} = V_{NO2}$ or $V_{NC2} = 3V,$ $R_L = 300\Omega, C_L = 35pF,$ Test Circuit 3	11			TYP	ns
Skew	$T_{SKEW}$	$V_S = 5V, R_S = 39\Omega, C_L = 50pF,$ Test Circuit 4	9			TYP	ns
		$V_S = 3V, R_S = 39\Omega, C_L = 50pF,$ Test Circuit 4	9			TYP	ns
Off Isolation	$O_{ISO}$	$R_L = 50\Omega,$ Signal = 0dBm, $C_L = 5pF,$ Test Circuit 5	f=10MHz	-45		TYP	db
			f=1MHz	-66		TYP	db
-3dB Bandwidth	BW	$R_L = 50\Omega,$ Signal = 0dBm, $C_L = 5pF,$ Test Circuit 6	120			TYP	MHz
Source OFF Capacitance	$C_{NC(OFF)}, C_{NO(OFF)}$	f=1MHz	15			TYP	pF
Channel ON Capacitance	$C_{NC(ON)}, C_{NO(ON)}, C_{COM(ON)}$	f=1MHz	50			TYP	pF
<b>POWER REQUIREMENTS</b>							
Power Supply Range	$V_S$		1.8			MIN	V
Power Supply Range	$V_S$		5.5			MAX	V
Power Supply Current	$I_S$	$V_{IN} = 0V$ or $V_S$	1			MAX	$\mu A$

**Typical Performance characteristics**

At  $T_A=+25^{\circ}\text{C}$ , and  $V_S=+5\text{V}$ , unless otherwise noted.

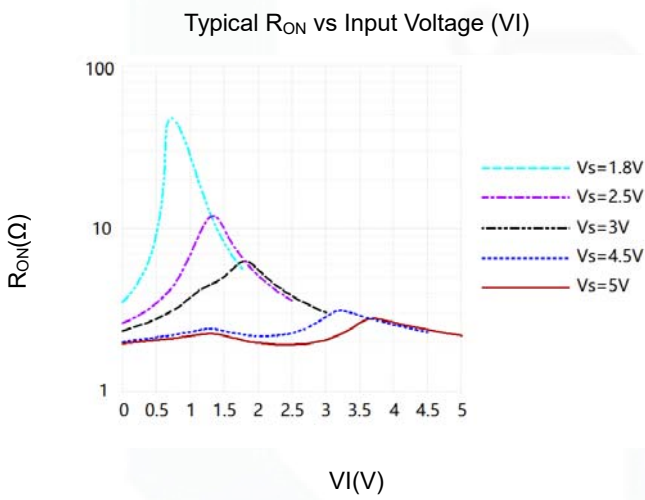
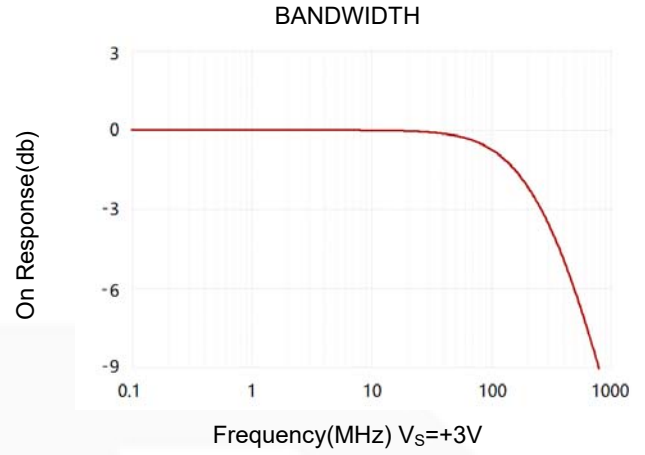
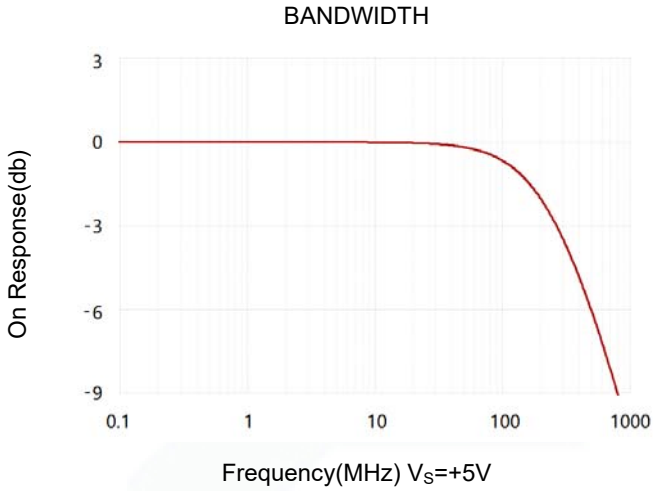

**Parameter Measurement Information**

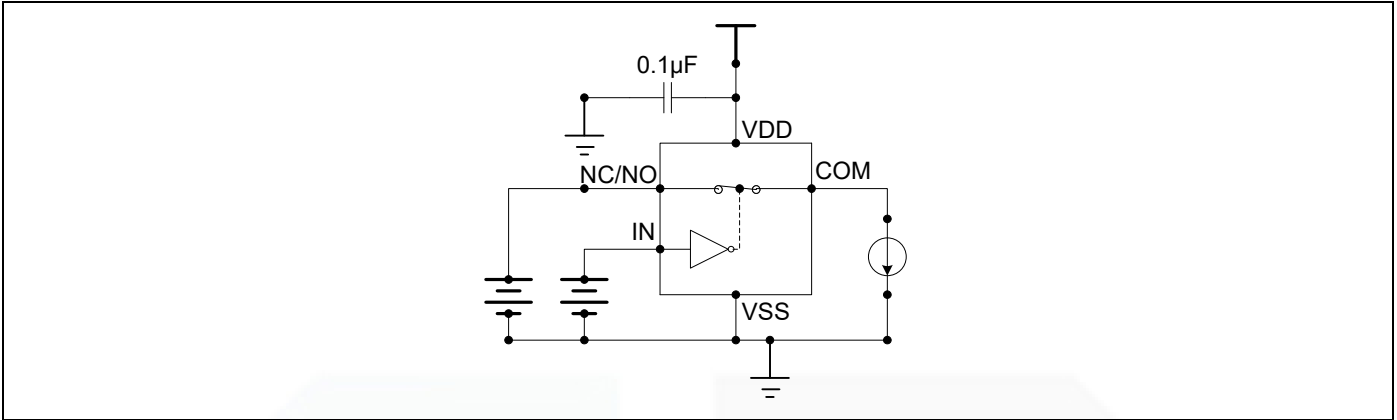

Test Circuit 1. On-Resistance

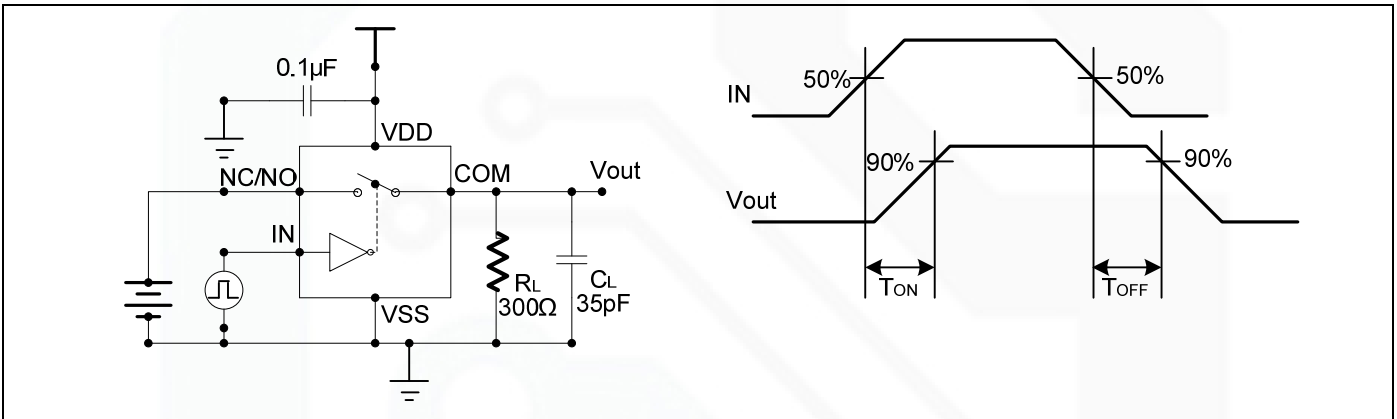

Test Circuit 2. Switching Times

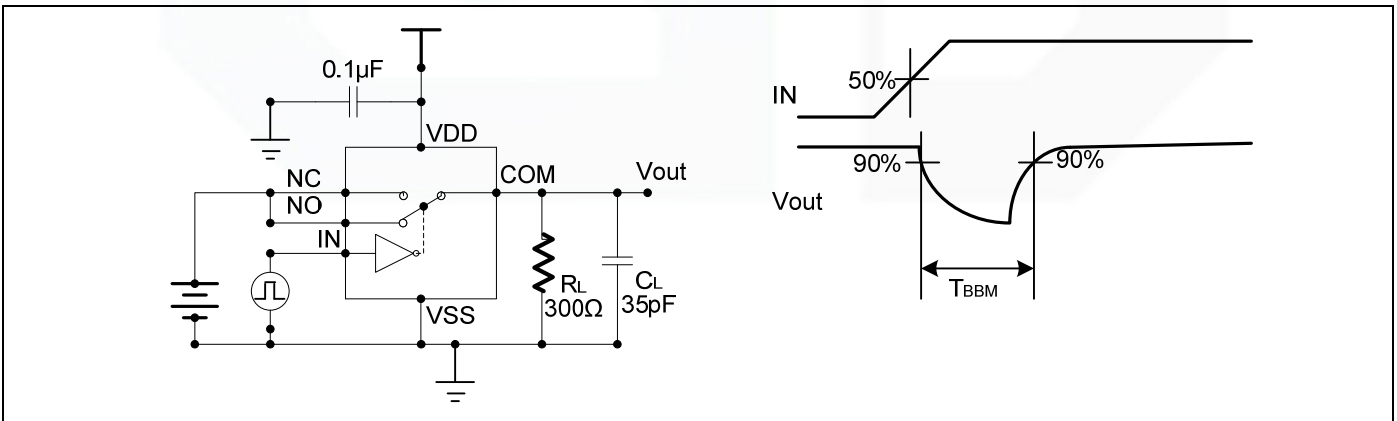

Test Circuit 3. Break-Before-Make Time Delay

**Parameter Measurement Information**

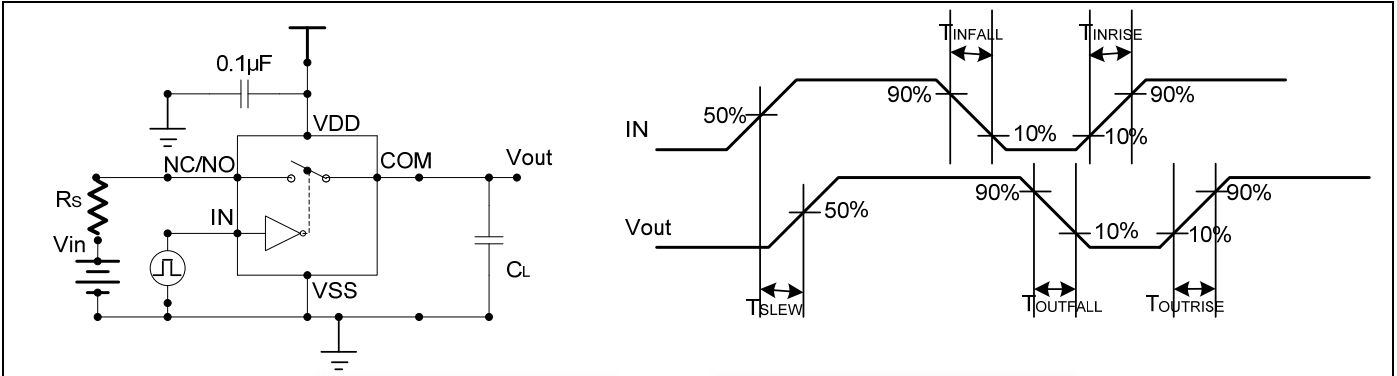

Test Circuit 4. Output Signal Skew

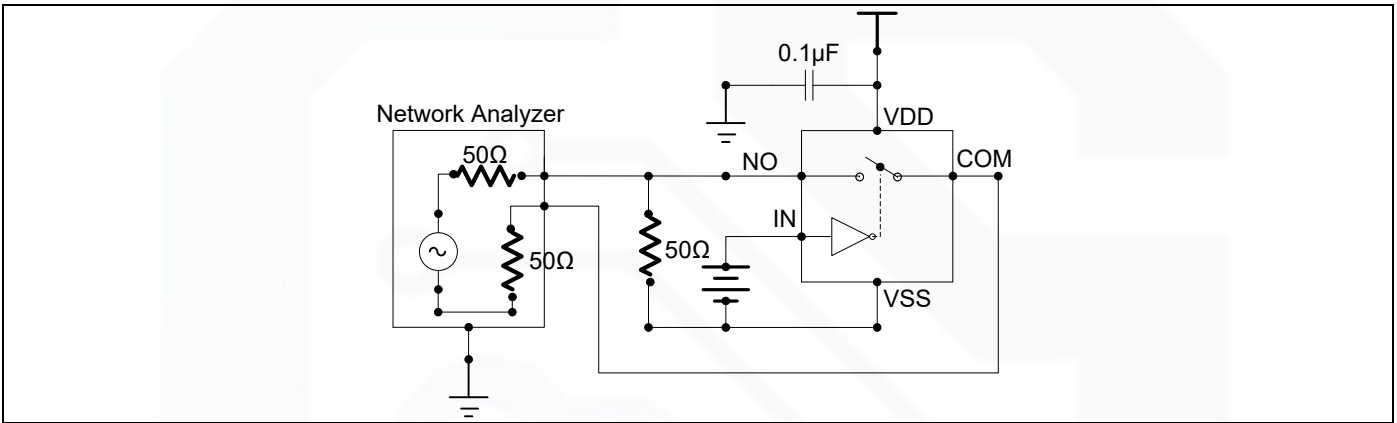

Test Circuit 5. Off Isolation

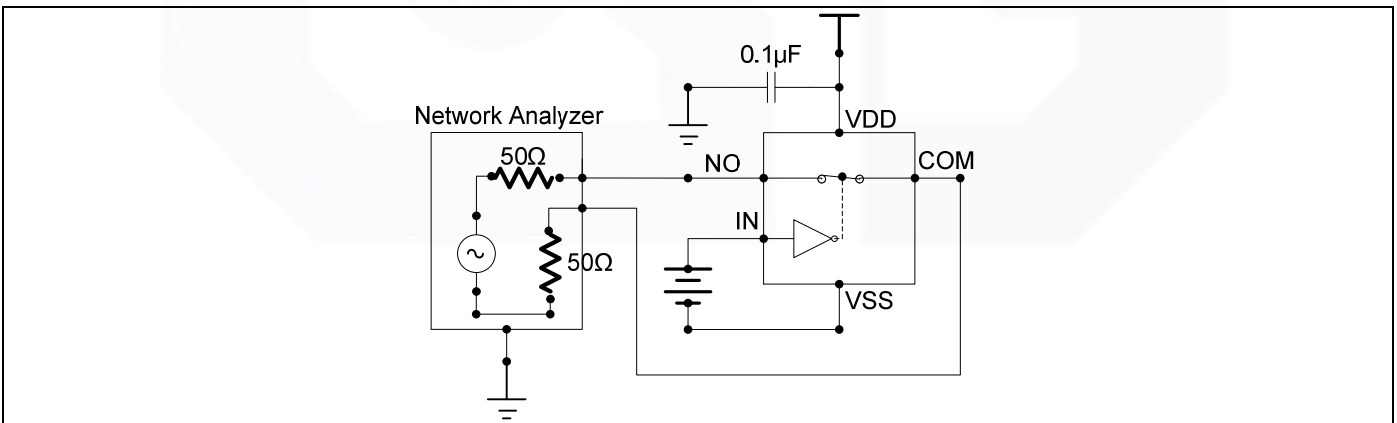

Test Circuit 6. -3dB Bandwidth

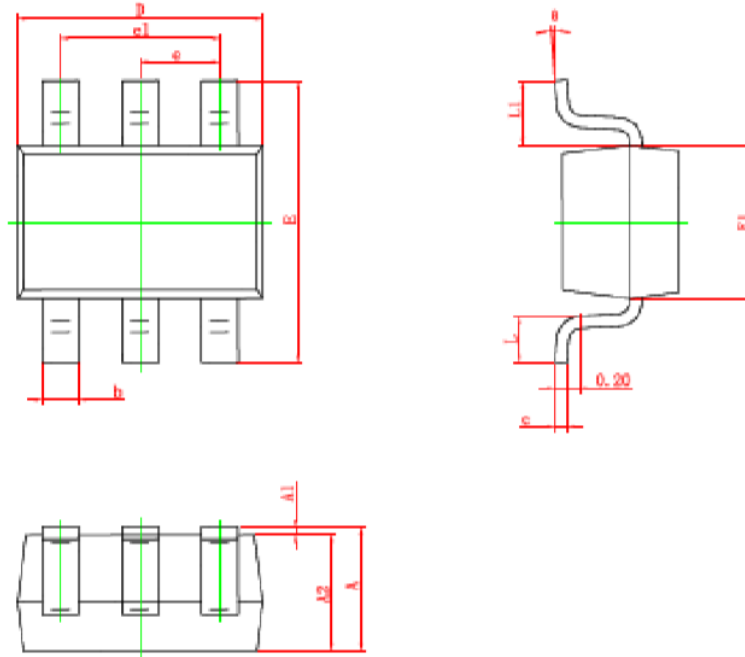

**Package Information**
**SC70-6**

Symbol	Dimensions In Millimeters		Dimensions In Inches	
	Min.	Max.	Min.	Max.
A	0.900	1.100	0.035	0.043
A1	0.000	0.100	0.000	0.004
A2	0.900	1.000	0.035	0.039
b	0.150	0.350	0.006	0.014
c	0.080	0.150	0.003	0.006
D	2.000	2.200	0.079	0.087
E	2.150	2.450	0.085	0.096
E1	1.150	1.350	0.045	0.053
e	0.650 TYP.		0.026 TYP.	
e1	1.200	1.400	0.047	0.055
L	0.260	0.460	0.010	0.018
L1	0.525 REF.		0.021 REF.	
$\theta$	0°	8°	0°	8°

**SOT23-6**

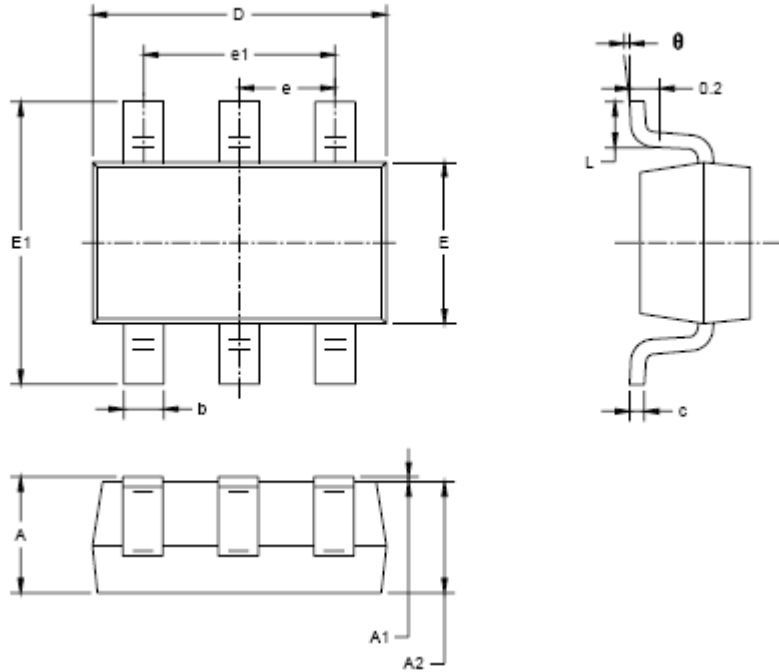

Symbol	Dimensions In Millimeters		Dimensions In Inches	
	MIN	MAX	MIN	MAX
A	1.050	1.250	0.041	0.049
A1	0.000	0.100	0.000	0.004
A2	1.050	1.150	0.041	0.045
b	0.300	0.500	0.012	0.020
c	0.100	0.200	0.004	0.008
D	2.820	3.020	0.111	0.119
E	1.500	1.700	0.059	0.067
E1	2.650	2.950	0.104	0.116
e	0.950 BSC		0.037 BSC	
e1	1.900 BSC		0.075 BSC	
L	0.300	0.600	0.012	0.024
$\theta$	0°	8°	0°	8°

## X-ON Electronics

Largest Supplier of Electrical and Electronic Components

*Click to view similar products for [Analogue Switch ICs](#) category:*

*Click to view products by [Gainsil](#) manufacturer:*

Other Similar products are found below :

[FSA3051TMX](#) [NLAS4684FCTCG](#) [NLAS5223BLMNR2G](#) [NLVAS4599DTT1G](#) [NLX2G66DMUTCG](#) [425541DB](#) [425528R](#) [099044FB](#)  
[MAX4762ETB+](#) [NLAS5123MNR2G](#) [PI5A4157CEX](#) [PI5A4599BCEX](#) [NLAS4717EPFCT1G](#) [PI5A3167CCEX](#) [SLAS3158MNR2G](#)  
[PI5A392AQEX](#) [PI5A392AQE](#) [FSA634UCX](#) [NX3L1T5157GMZ](#) [ADG714BCPZ-REEL7](#) [HT4051ARZ](#) [TC4066BP\(N,F\)](#) [DG302BDJ-E3](#)  
[ADG854BCPZ-REEL7](#) [PI5A100WE](#) [PI5A100QEX](#) [HV2733FG-G](#) [HV2701FG-G](#) [HV2301FG-G](#) [HV2301FG-G-M931](#) [RS2117YUTQK10](#)  
[RS2118YUTQK10](#) [RS2227XUTQK10](#) [ADG452BRZ-REEL7](#) [MAX391CPE+](#) [MAX4744ELB+](#) [MAX4730EXT+T](#) [MAX4730ELT+](#)  
[MAX333AEWP+](#) [BU4066BC](#) [MAX313CPE+](#) [BU4S66G2-TR](#) [NLASB3157MTR2G](#) [NX3L4684TK,115](#) [NX5L2750CGUX](#)  
[NLAS4157DFT2G](#) [NLAS4599DFT2G](#) [NLASB3157DFT2G](#) [NLAST4599DFT2G](#) [NLAST4599DTT1G](#)