

Features

- **Large Signal Voltage Gain: 110dB Typical**
- **Low Input Noise Voltage: 0.7 μ VRMS (RIAA) Typical**
- **Wide Gain Bandwidth Product: 15MHz at 10KHz Typical**
- **Low Distortion: 0.0005% Typical**
- **Slew Rate: 7V/ μ s Typical**

General Description

The GS4580 is a monolithic dual low noise operational amplifier. It is specifically designed for audio systems to improve tone control; it can also be used in preamplifier, industrial measurement tools and applications where gain and phase matched channels are mandatory. The IC features internal frequency compensation, low noise, low distortion, high gain and high bandwidth. The GS4580 can operate under dual power supply voltage up to $\pm 18V$ or single power supply up to 36V. The GS4580 is available in DIP-8, SOIC-8 and TSSOP-8 packages.

Applications

- **Audio AC-3 Decoder System**
- **Audio Amplifier**

Pin Configuration

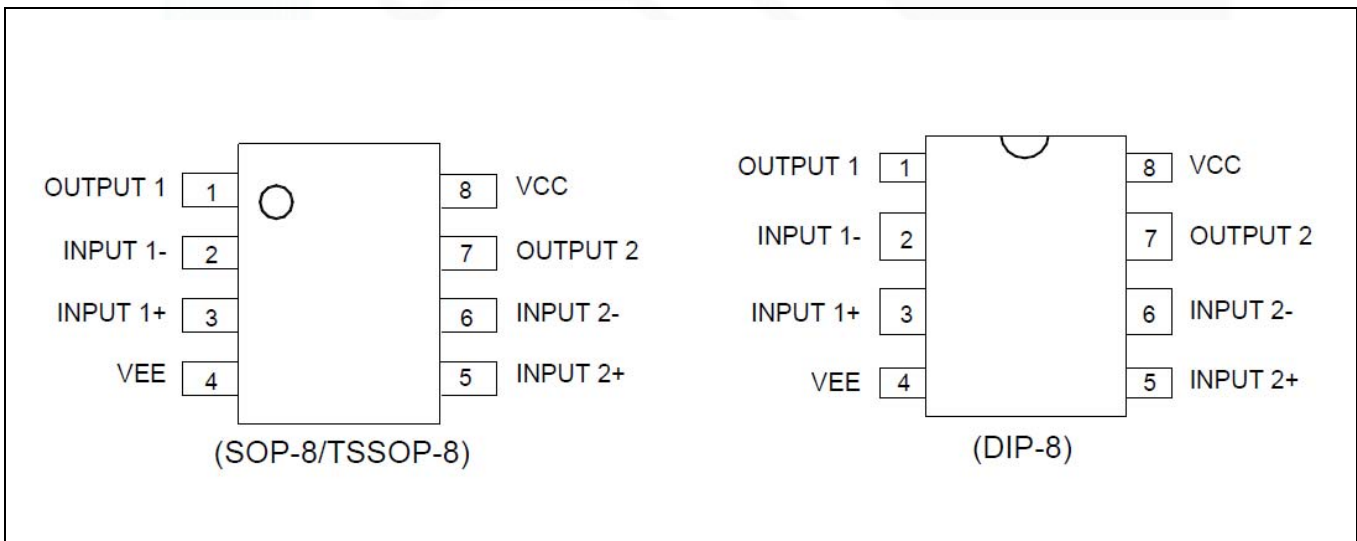

Figure 1. Pin Configuration of GS4580

Functional Block Diagram

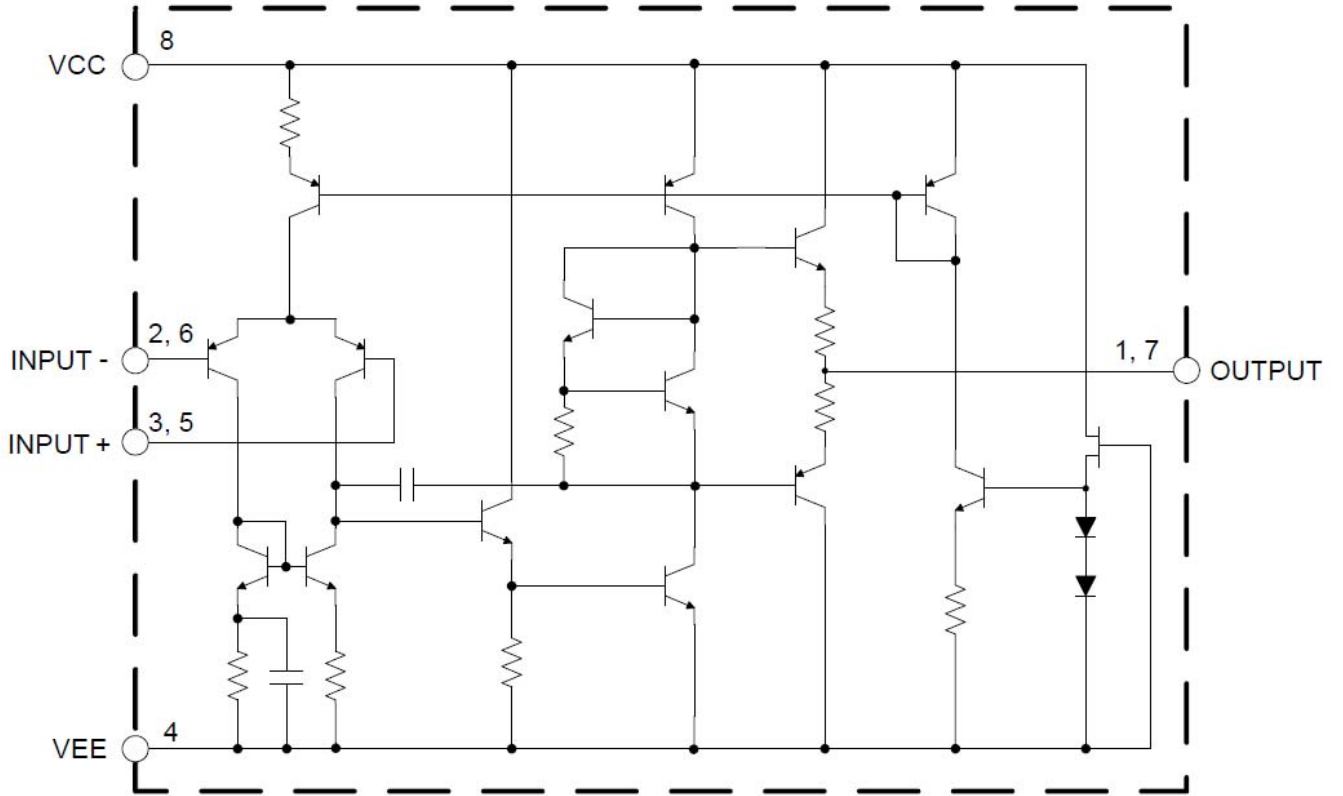

Figure 2. Representative Schematic Diagram of GS4580 (Each Amplifier)

Absolute Maximum Ratings (Note 1)

Parameter	Smbol	Value		Unit
Power Supply Voltage	V_{CC}	+ 20		V
	V_{EE}	- 20		
Input Voltage	V_I	± 15		V
Differential Input Voltage	V_{ID}	± 30		V
Operating Junction Temperature	T_J	150		$^{\circ}C$
Storage Temperature Range	T_{STG}	-65 to 150		$^{\circ}C$
Lead Temperature (Soldering 10s)	T_L	260		$^{\circ}C$
Power Dissipation ($T_A=25^{\circ}C$)	P_D	TSSOP-8	400	mW
		SOIC-8	500	
		DIP-8	800	

Note 1: Stresses greater than those listed under "Absolute Maximum Ratings" may cause permanent damage to the device. These are stress ratings only, and functional operation of the device at these or any other conditions beyond those indicated under "Recommended Operating Conditions" is not implied. Exposure to "Absolute Maximum Ratings" for extended periods may affect device reliability.

Recommended Operating Conditions

Parameter	Min	Max	Unit
Supply Voltage	± 2	± 18	V
Operating Temperature Range	-40	85	$^{\circ}C$

Package/Ordering Information

MODEL	CHANNEL	ORDER NUMBER	PACKAGE DESCRIPTION	PACKAGE OPTION	MARKING INFORMATION
GS4580	dual	GS4580-SR	SOP-8	Tape and Reel,4000	GS4580
		GS4580-TR	TSSOP8	Tape and Reel,3000	GS4580
		GS4580-DR	DIP8	20Tube(1000pcs)	GS4580

Electrical Characteristics

Operating Conditions: $V_{CC}=+15V$, $V_{EE}=-15V$, $T_A=25^{\circ}C$ unless otherwise specified.

Parameter	Conditions	Min	Typ	Max	Unit
Supply Current	no load		4	7	mA
Input Offset Voltage	$R_S \leq 10K\Omega$		0.5	3	mV
Input Offset Current	$V_{CM}=0V$		5	100	nA
Input Bias Current	$V_{CM}=0V$		150	500	nA
Input Common Mode Voltage Range		± 12	± 13.5		V
Common Mode Rejection Ratio	$V_{CM}=0V$ to $V_{CC}-1.5V$, $R_S \leq 10K\Omega$	80	110		dB
Large Signal Voltage Gain	$R_L=2K\Omega$, $V_O=\pm 10V$	90	110		dB
Power Supply Rejection Ratio	$R_S \leq 10K\Omega$	80	110		dB
Output Sink Current	$V_- = -1V$, $V_+ = 0V$, $V_O = 2V$		80		mA
Output Source Current	$V_+ = 1V$, $V_- = 0V$, $V_O = 2V$		45		mA
Slew Rate	$R_L \geq 2K\Omega$		7		V/ μ S
Gain Bandwidth Product	$R_L=2K\Omega$, $f=10KHz$		15		MHz
Total Harmonic Distortion	$A_V=20dB$, $V_O=5V$ $R_L=2K\Omega$, $f=1KHz$		0.0005		%
Equivalent Input Noise Voltage	RIAA $R_S=50\Omega$, 30KHz LPF		0.7		μV_{RMS}
Thermal Resistance (Junction to Case)	DIP-8		43		$^{\circ}C/W$
	SOIC-8		63		

Typical Performance characteristics

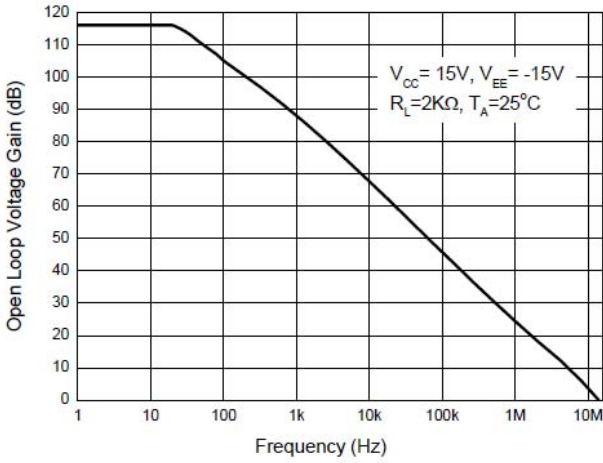

Figure 3. Open Loop Voltage Gain vs. Frequency

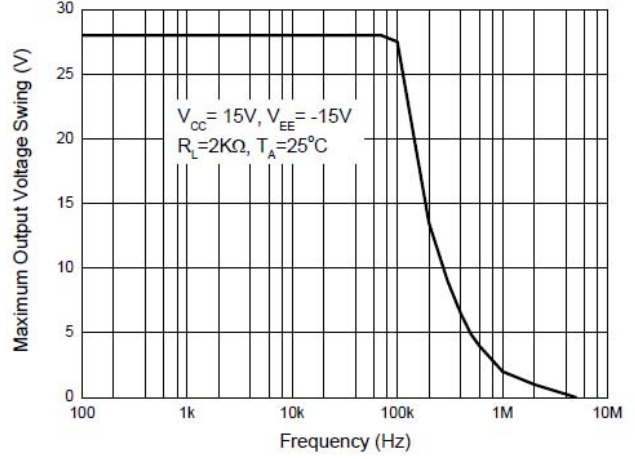

Figure 4. Maximum Output Voltage Swing vs. Frequency

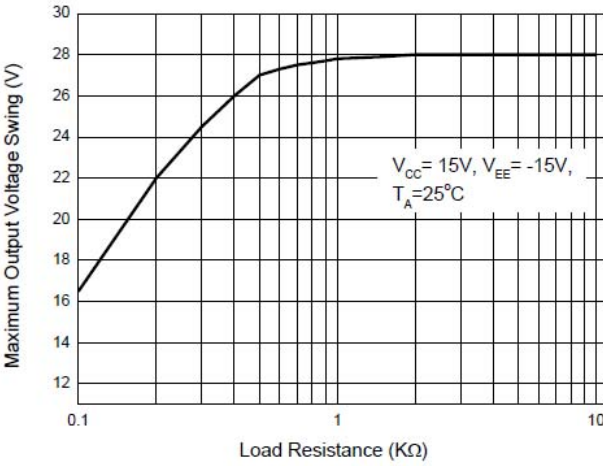

Figure 5. Maximum Output Voltage Swing vs. Load Resistance

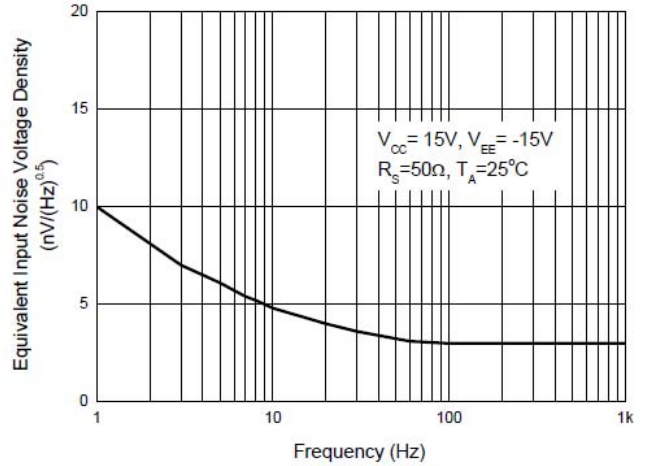

Figure 6. Equivalent Input Noise Voltage Density vs. Frequency

Typical Performance Characteristics (Continued)

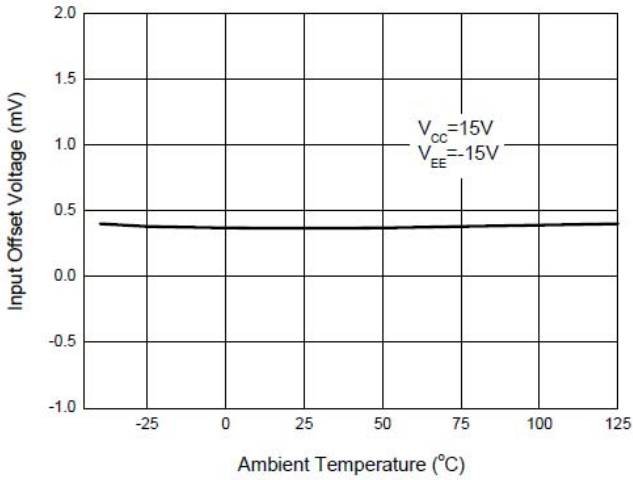

Figure 7. Input Offset Voltage vs. Temperature

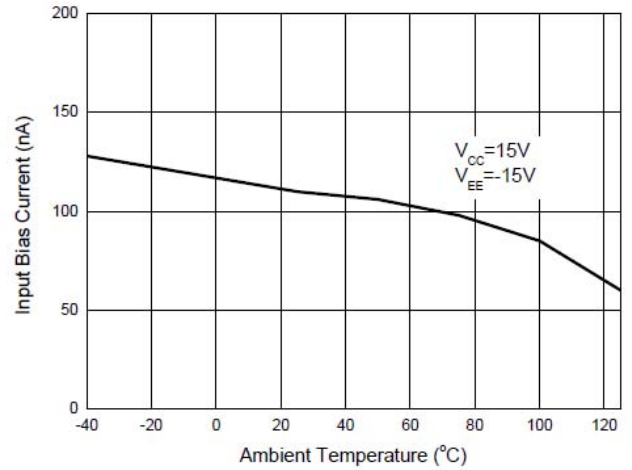

Figure 8. Input Bias Current vs. Temperature

Typical Applications

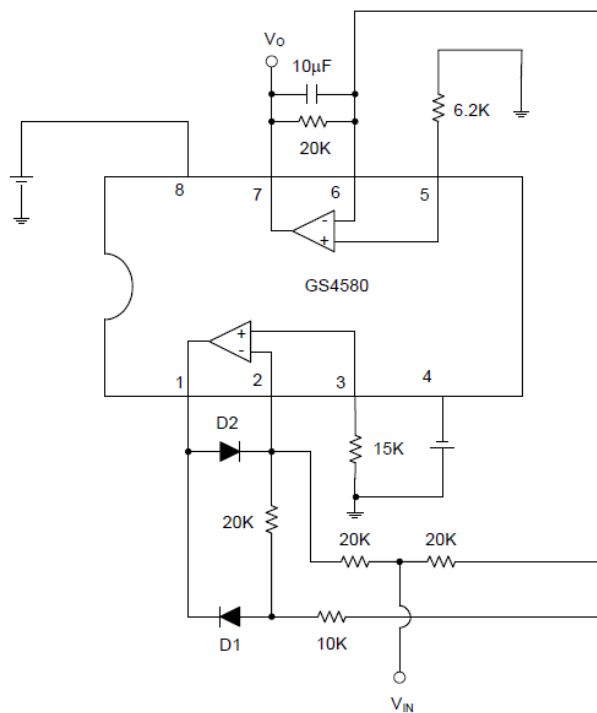

Figure 9. Application of GS4580 in an AC/DC Converter

Typical Applications(Continued)

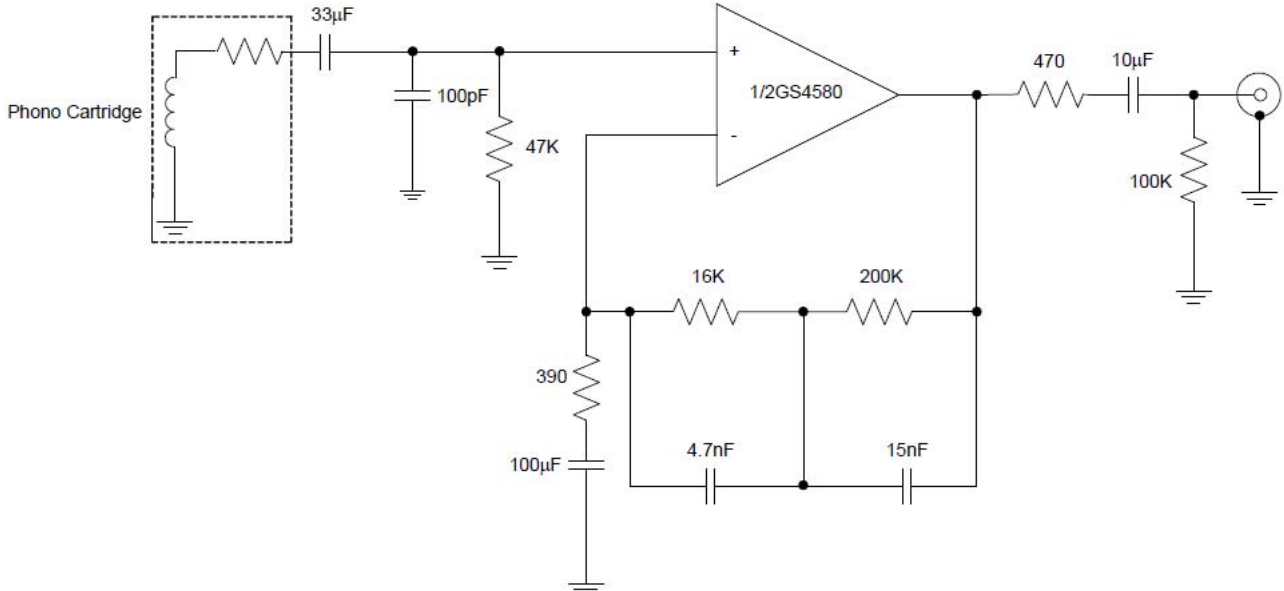

Figure 10. Application of GS4580 in a RIAA Preamp

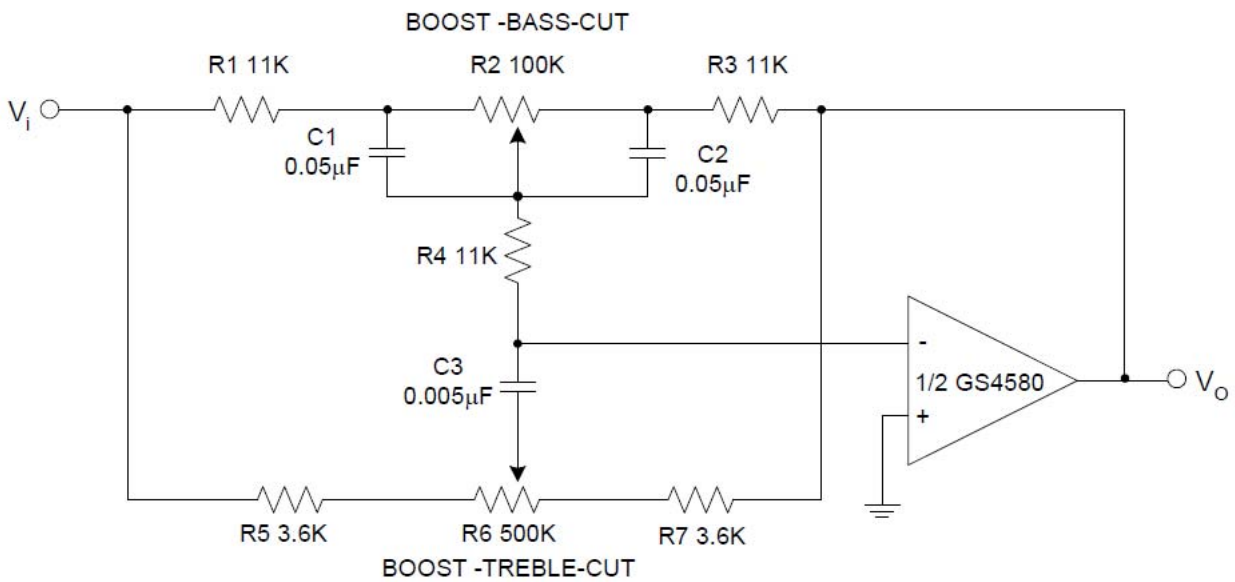
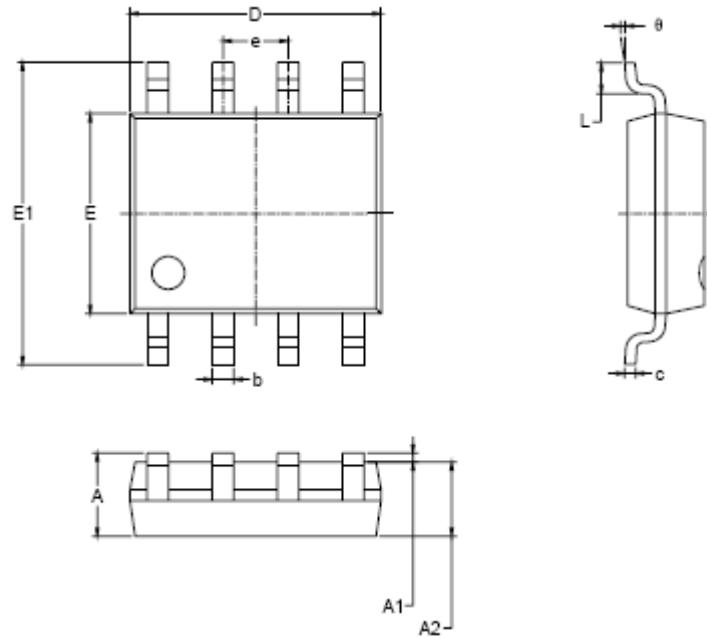

Figure 11. Application of GS4580 in Tone Control

Package Information

SOP-8



Symbol	Dimensions In Millimeters		Dimensions In Inches	
	MIN	MAX	MIN	MAX
A	1.350	1.750	0.053	0.069
A1	0.100	0.250	0.004	0.010
A2	1.350	1.550	0.053	0.061
b	0.330	0.510	0.013	0.020
c	0.170	0.250	0.006	0.010
D	4.700	5.100	0.185	0.200
E	3.800	4.000	0.150	0.157
E1	5.800	6.200	0.228	0.244
e	1.27 BSC		0.050 BSC	
L	0.400	1.270	0.016	0.050
θ	0°	8°	0°	8°

TSSOP-8

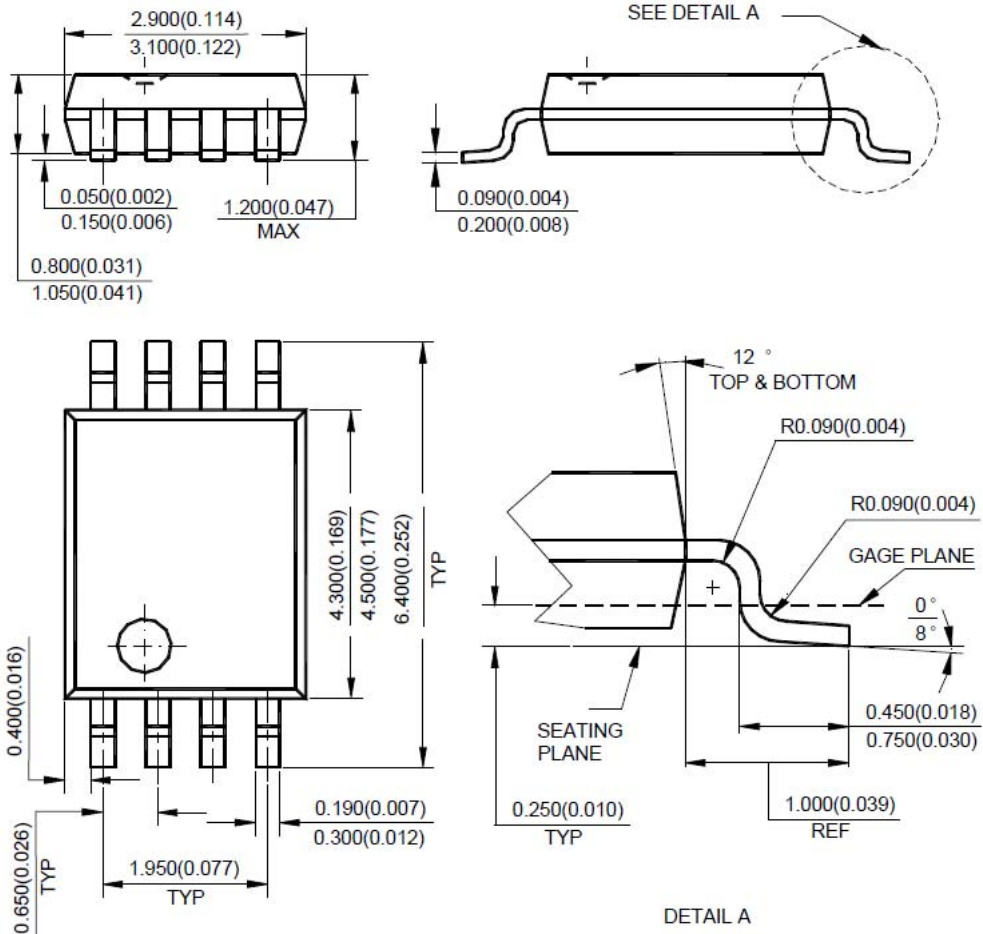

DIP-8

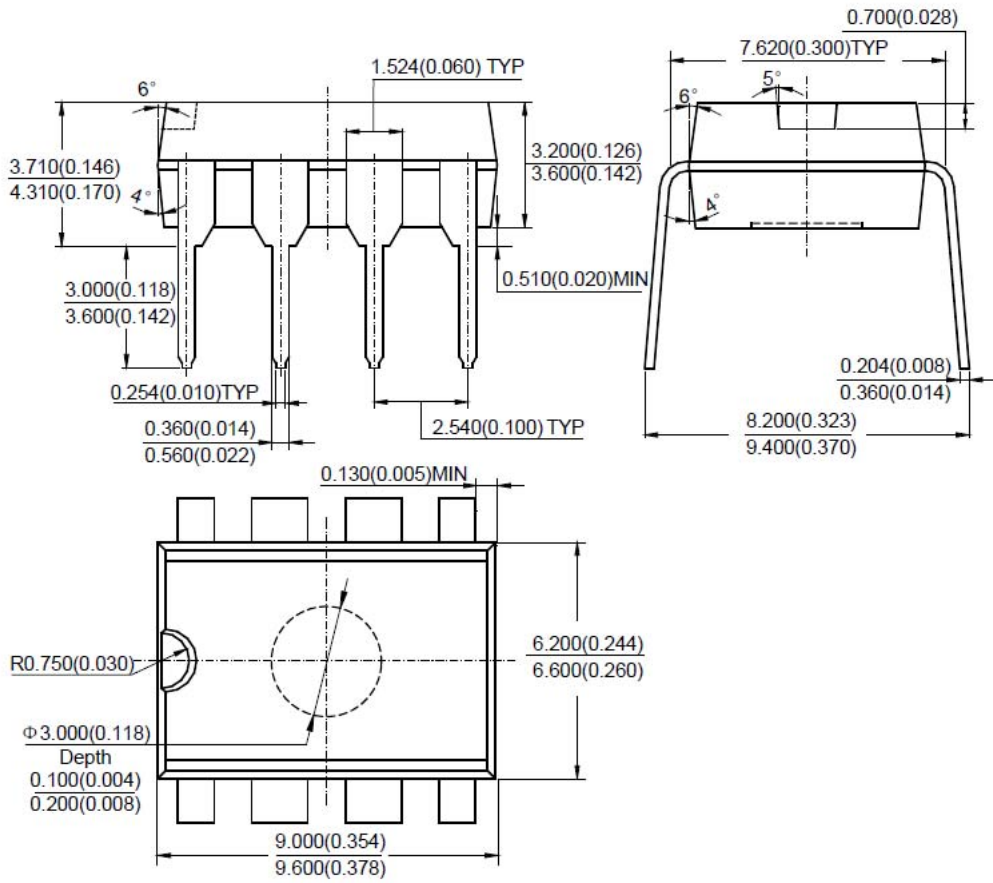

X-ON Electronics

Largest Supplier of Electrical and Electronic Components

Click to view similar products for [Operational Amplifiers - Op Amps](#) category:

Click to view products by [Gainsil](#) manufacturer:

Other Similar products are found below :

[430227FB](#) [UPC451G2-A](#) [UPC824G2-A](#) [LT1678IS8](#) [UPC258G2-A](#) [NCV33202DMR2G](#) [NJM324E](#) [NTE925](#) [AZV358MTR-G1](#)
[AP4310AUMTR-AG1](#) [AZV358MMTR-G1](#) [SCY33178DR2G](#) [NCV5652MUTWG](#) [NCV20034DR2G](#) [NTE778S](#) [NTE871](#) [NTE937](#)
[MCP6V16UT-E/OT](#) [SCY6358ADR2G](#) [UPC4570G2-E1-A](#) [NCS20282FCTTAG](#) [UPC834G2-E1-A](#) [UPC1458G2-E2-A](#) [UPC813G2-E2-A](#)
[UPC458G2-E1-A](#) [UPC824G2-E2-A](#) [UPC4574G2-E2-A](#) [UPC4558G2-E2-A](#) [UPC4560G2-E1-A](#) [UPC4062G2-E1-A](#) [UPC258G2-E1-A](#)
[UPC4742GR-9LG-E1-A](#) [UPC4742G2-E1-A](#) [UPC832G2-E2-A](#) [UPC842G2-E1-A](#) [UPC802G2-E1-A](#) [UPC4741G2-E2-A](#) [UPC4572G2-E2-A](#)
[UPC844GR-9LG-E2-A](#) [UPC259G2-E1-A](#) [UPC4741G2-E1-A](#) [UPC4558G2-E1-A](#) [UPC4574GR-9LG-E1-A](#) [UPC1251GR-9LG-E1-A](#)
[UPC4744G2-E1-A](#) [UPC4092G2-E1-A](#) [UPC4574G2-E1-A](#) [UPC4062G2-E2-A](#) [UPC451G2-E2-A](#) [UPC832G2-E1-A](#)