

APPROVAL SPECIFICATIONS

Title. DC插座

Product Model. DC-470 2.0/351

Customer's Part NO.

Customer's Model:

Customer's Approval Requested.

Please return this copy as a certification of your approval.

Checked by: _____ Date: _____

Approved by: _____ Date: _____

APPROVE	REVIEW	POLT
Jack Wu	孙斌	徐明娥

Shenzhen Gangyuan Microkey Technology Co.,ltd

3.3	<p>DIELECTRIC STRENGTH 耐电压</p>	<p>AC 500V 5ms(50~60Hz)FOR 1 MIN TRIP CURRENT:0.5mA (1) BETWEEN BODY AND CONDUCTOR (2) BETWEEN CONDUCTORS NOT TO BE CONTACT (3) BETWEEN CONDUCTORS NOT TO BE WHEN PLUG IS INSERTED DC 500V 1 MIN 输入 AC 500V (50Hz)/min 电压 1 分钟感度电流为 0.5mA, 按以下接触方法测试: (1) 插座体与排脚之间 (2) 不接触的排脚之间 (3) 插头插入时不接触排脚之间</p>	<p>WITHOUT DAMAGE TO PARTS ARCING OR BREAKDOWN ETC 没有绝缘破坏等异常</p>
-----	------------------------------------	---	--

URABILITY (耐久性)

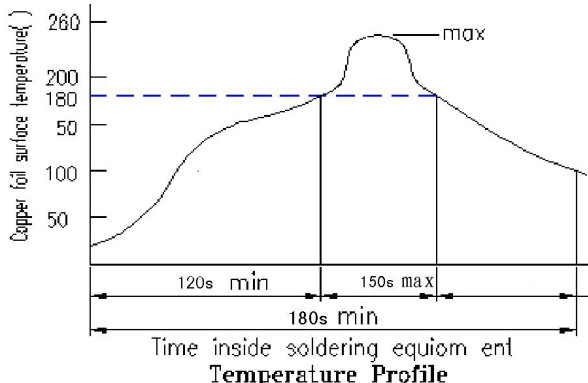
ITEM 项目	TEST CONDITIONS 测试条件	PERFORMANCE 规格
4.1	<p>SOLDERABILITY TEST 可焊性试验</p> <p>THE TOP OF THE TERMINALS SHALL BE DIPPED 1mm IN THE SOLDER BATH OF 240±5°C FOR 3±0.5 SECONDS 端子顶部被浸入锡池中 1mm 深,温度为 230±5°C,时间为 3±0.5 秒</p>	<p>(1) SOLDER WETTING TIME SHALL BE 3 SEC OR LESS 焊接时间应少于 3 秒 (2) THE AREA OF SOLDERING SHOULD BE OVER 75% 焊接面积应有 75%以上</p>
4.2	<p>RESISTANCE TO SOLDERING HEAT TEST 耐焊性试验</p> <p>REFLOW SOLDERING CONDITIONS: PREHEAT:TEMPERATURE ON THE COPPER FOIL SURFACE SHOULD REACH 180 °C .120S AFTER THE P.C.B ENTERED INTO THE SOLDERING EQUIPMENT. TALLEST TEMPERATURE:TEMPERATURE ON THE COPPER FOIL SURFACE SHOULD REACH THE PEAK TEMPERATURE OF 260±5°C WITH IN 20 SECONDS.</p> <p>过回流焊条件: 预热:电镀层表面的温度应达到 180°C,120s 后电路板进入回流焊设备。 最高温度:电镀层表面温度最高为 230±5°C且停留不超过 20 秒。</p>  <p style="text-align: center;">Temperature Profile</p>	<p>WITHOUT DEFOR MATION OF CASE OR EXCESSIVE LOOSENESS OF TEMINALS ELECTRICAL CHARACTERISTICS SHALL BE SATISFIED 本体无变形, 满足于机械、电气性能</p>

4.2	RESISTANCE TO SOLDERING HEAT TEST 耐焊性试验	<p>SOLDERING IRON METHOD: BIT TEMPERATURE $330 \pm 5^{\circ}\text{C}$ APPLICATION TIME OF SOLDERING IRON 3 ± 0.5 SEC HOWEVER EXCESSIVE PRESSURE SHALL NOT BE APPLIED TO THE TERMINAL 手焊接的时候温度需控制在 $330 \pm 5^{\circ}\text{C}$, 时间为 3 ± 0.5 秒, 但不能在排脚上施加异常压力。</p> <p>SOLDERING IRON METHOD: BIT TEMPERATURE $330 \pm 5^{\circ}\text{C}$ APPLICATION TIME OF SOLDERING IRON 3 ± 0.5 SEC HOWEVER EXCESSIVE PRESSURE SHALL NOT BE APPLIED TO THE TERMINAL 手焊接的时候温度需控制在 $330 \pm 5^{\circ}\text{C}$, 时间为 3 ± 0.5 秒, 但不能在排脚上施加异常压力。</p>	
4.3	HUMIDITY TEST 潮湿试验	<p>THE JACK SHALL BE STORED AT A TEMPERATURE OF $40 \pm 2^{\circ}\text{C}$ AND A HUMIDITY OF 90% TO 96% FOR 96 Hr, THEN THE JACK SHALL BE MAINTAINED AT STANDARD ATMOSPHERIC CONDITION FOR 1 Hr FOR OTHER PROCEDURES 放置 $40 \pm 2^{\circ}\text{C}$ 的相应湿度为 90~96% Hr 环境中 96 小时后, 再将样板放在正常环境中 1 小时后进行测试</p>	<p>THERE SHALL BE NO DAMAGE ON APPEARANCE. MECHANICAL AND ELECTRICAL CHARACTERISTICS SHALL BE SATISFIED 外观无异常, 满足于机械、电气性能。</p>
4.4	HEAT TEST 耐热试验	<p>THE JACK SHALL BE STORED AT A TEMPERATURE OF $70 \pm 2^{\circ}\text{C}$ FOR 96 HOURS, AND THEN IT SHALL BE SUBJECTED TO THE CONTROLLED RECOVERY MBASURBM 放置在温度 $70 \pm 2^{\circ}\text{C}$ 中测试 96 小时后, 再放置正常室温中 1 小时来测定</p>	
4.5	COLD TEST 耐寒试验	<p>THE JACK SHALL BE STORED AT A TEMPERATURE OF $-25 \pm 3^{\circ}\text{C}$ FOR 96 HOURS AND THEN IT SHALL BE SUBJECTED TO THE CONTROLLED RECOVERY CONDITIONS FOR 1 HOUR AFTER WHICH 放置在温度 $-25 \pm 3^{\circ}\text{C}$ 中 96 小时后, 再放置常温常湿中 1 小时来测定</p>	<p>THERE SHALL BE NO DAMAGE ON APPEARANCE MECHANICAL AND ELECTRICAL CHARACTERISTICS SHALL BE SATISFIED 外观无异常, 满足于机械、电气性能</p>
4.6	LIFE TEST 寿命试验	<p>WITHOUT LOAD CONNECTION AND DISCONNECTION SHALL BE MADE WITH THE MATING PLUGS AND JACKS FOR 5, 000 CYCLES AT A SPEED OF 10 TO 25 CYCLES/MIN 无负荷 将结合了的标准 Plug(尽量要近于中心的)在 1 分钟内以 10~25 的速度, 进行 5, 000 次插入, 拔出 LOAD: AT RATING CONDITION (NON-INDUCTIVE LOAD) CONNECTION AND DISCONNECTION SHALL BE MADE 1,000 CYCLES AT A SPEED 10 TO 20 CYCLES / MIN 负荷 以定格状态(无诱导负荷)在 1 分钟内以 10~20 次的速度进行 1,000 次插入、拔出</p>	<p>(1) CONTACT RESISTANCE SHALL BE $\leq 0.1 \Omega$ (2) DISCONNECTION FORCE SHALL BE 3 TO 20N (3) MECHANICAL AND ELECTRICAL CHARACTERISTICS SHALL BE SATISFIED (1) 接触电阻 $\leq 0.1 \Omega$ (2) 拔出力是 3~20N (3) 其它: 满足于机械、电气性能</p>

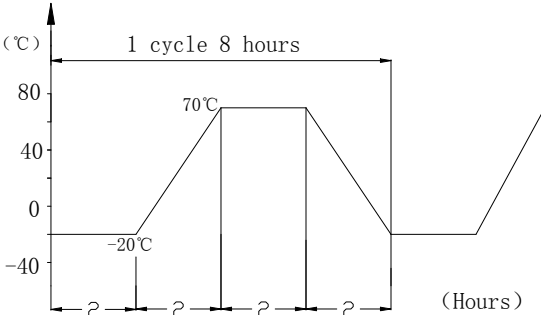
<p>4.7</p>	<p>TEMPARATURE CYCLINGTEST 温度循环测试</p>	<p>THE JACK SHALL BE SUB JECTED TO 5 CYCLES OF THE FOLLOWING CONDITIONS SHOWED IN THE FIGURE,AND THEN SHALL RETURNED ALLOWED TO REMAIN IN ROOM AMBIENT CONDITION FOR 30 MINUTES 将插座以下列条件作 5 个循环, 然后放回室内环境 30 分钟</p> 	<p>THERE SHALL BE NO DEFORMATION OR CRACKS IN MOLDED PART. INSERTION & EXTRACTION FORCE:3 TO 20N CONTACT RESISTANCE:MAX.30M Ω INSULATION RESISTANCE: MIN.100 M Ω DIELECTRIC WITHSTANDING VOLTAGE: 500VAC/MIN(BETWEEN TERMINALS)</p> <p>产品不能变形与破裂 插拔力: 3N 至 20N 接触电阻: 最大 30m Ω 绝缘电阻: 最小 100 M Ω 绝缘耐压: 最小 500VAC (端子之间)</p>
------------	---	---	---

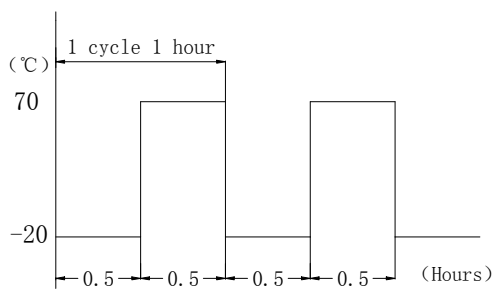
<p>4.8</p>	<p>Cold&HEAT SHOCK TEST 冷热冲击测试</p>	<p>THE JACK SHALL BE SUBJECTED TO 5 CYCLES OF THE FOLLOWING CONDITIONS SHOWED IN THE FIGURE,AND THEN SHALL RETURNED AND ALLOWED TO REMAIN IN ROOM AMBIENT CONDITION FOR 30 MINUTES 将插座以下列条件作 5 个循环, 然后放回室内环境 30 分钟 TEMP (°C)</p> 	<p>THERE SHALL BE NO DEFORMATION OR CRACKS IN MOLDED PART. INSERTION & EXTRACTION FORCE:3 TO 20N CONTACT RESISTANCE:MAX.30M Ω INSULATION RESISTANCE: MIN.100 M Ω DIELECTRIC WITHSTANDING VOLTAGE: 500VAC/MIN(BETWEEN TERMINALS)</p> <p>产品不能变形与破裂 插拔力: 3N 至 20N 接触电阻: 最大 30m Ω 绝缘电阻: 最小 100 M Ω 绝缘耐压: 最小 500VAC (端子之间)</p>
------------	--	--	---

材料

NO.	NAME	
1	盖板	PA66 (黑色)
2	基座	PA66 (黑色)
3	插针	H59-1 黄铜 ϕ 2.0
4	静触片	铁皮 t= 0.3
5	动触片	高精磷铜 t=0.25
6	插针脚	铁皮 t=0.35

制 表	校 对	审 核	备注: 共四页
徐明娥	孙斌	吴观江	

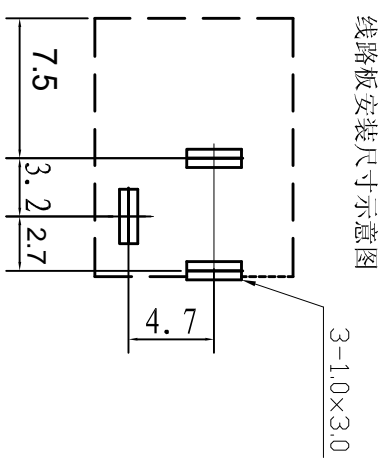
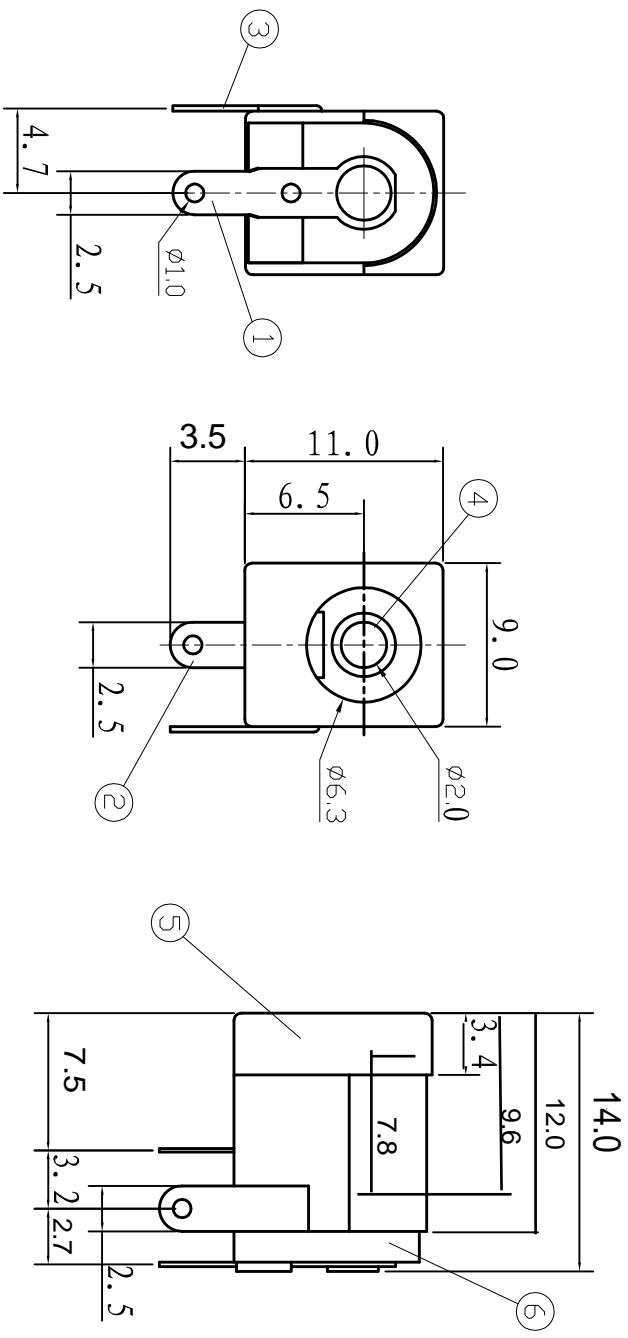

技术要求

使用条件: $-40 \sim 55^{\circ}\text{C}$
 额定负荷: DC 30V 1.0A
 接触电阻: $\leq 0.03\Omega$
 绝缘电阻: $\geq 100M\Omega$ DC250V
 耐压: AC 500V(50Hz)/min
 插拔力: 3~20N
 机械寿命: 5000次

TOLERANCE: UNLESS OTHERWISE SPECIFIED

UNOER 1.5 \pm 0.05	1.5 \sim 10 \pm 0.1	OVER 10 \pm 0.2
----------------------	-------------------------	-------------------

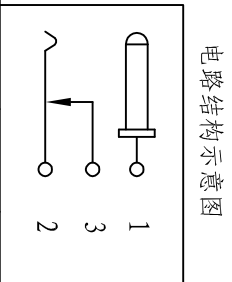

序号	零件图号或代号	名称	数量	材料	备注
6		盖板	1PCS	PA 66 (黑色)	
5		底座	1PCS	PA 66 (黑色)	
4		插针	1PCS	H59-1黄铜 $\phi = 2.0$	电镀: 锡
3		静触点	1PCS	铁皮	电镀: CT
2		动触点	1PCS	高精磷铜 $t=0.25$	电镀: CT
1		插针脚	1PCS	铁皮 $t=0.35$	电镀: CT

DC-470 ϕ 2.0/351
电源插座

深圳市港源实业发展有限公司

阶段	标记	质量	比例
A			1:1

标记	数量	更改单号	签名	日期

旧底图总号	
底图总号	
日期	
签名	

设计	
审核	
工艺	
标准化	
批准	

X-ON Electronics

Largest Supplier of Electrical and Electronic Components

Click to view similar products for [DC Power Connectors](#) category:

Click to view products by [GANGYUAN](#) manufacturer:

Other Similar products are found below :

[1600206-1](#) [163-0308-EX](#) [163-4012-EX](#) [163-4117-EX](#) [163-7421](#) [163-MJ22-EX](#) [171-0721-EX](#) [KLDX-SMT-0202-BPTR](#) [163-0179-EX](#) [163-1000-EX](#) [163-4007-EX](#) [163-4015-EX](#) [171-0722-E](#) [171-7391](#) [K596](#) [KLD-0201-BC](#) [KPPX-D](#) [4C6831AX](#) [TS3PNJ](#) [E16550-0008](#) [VLP-12V-1](#)
[DC PLUG-P1J-P1MR](#) [DC PLUG-P1M-P1MR](#) [09442](#) [AS120-M](#) [CP30240](#) [TAMIYA-M](#) [TAMIYA-MT1](#) [TAMIYA-MT2](#) [4840.1200](#)
[4840.2202](#) [C5080HI-04P-18 + C5080HI-C](#) [JC-135](#) [JC-138](#) [JC-210](#) [JPO-25 \(FC6814\)](#) [JYO-26 \(FC6811\)](#) [JYO-29 \(FC68102\)](#) [KLBPS 3](#) [KLS](#)
[10 SCHWARZ](#) [KLS 3 SCHWARZ](#) [KLS 40 SCHWARZ](#) [KPJXHT-4S](#) [DC-10A FC68148](#) [DC-10B \(FC68149\)](#) [WKLS 2](#) [WKLS 40](#) [FA67555](#)
[XNES/J 210 SCHWARZ](#) [XNES/J 250 SCHWARZ](#) [FC68026](#)