

## **GSWP100W-EVBPA**

# **100W GaN E-HEMT Wireless Power Transfer Evaluation Board, Optimized for Class EF2 Amplifiers**

Technical Manual

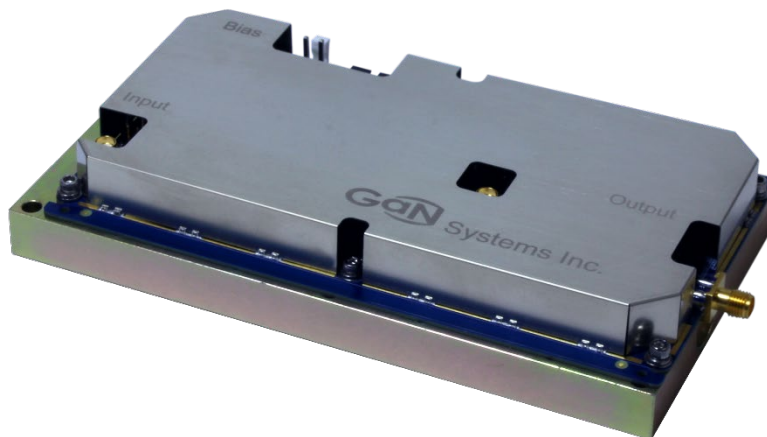

Visit [www.gansystems.com](http://www.gansystems.com) for the latest version of this technical manual.



**DANGER!**

Electrical Shock Hazard - Hazardous high voltage may be present on the board during the test and even brief contact during operation may result in severe injury or death. Follow all locally approved safety procedures when working around high voltage.

Never leave the board operating unattended. After it is de-energized, always wait until all capacitors are discharged before touching the board.

**This board should be handled by qualified personnel ONLY.**



PCB surface and devices can become hot. Contact may cause burns. Do not touch!

**CAUTION**

This product contains parts that are susceptible to damage by electrostatic discharge (ESD) or exposure to voltages in excess of the specified voltage. Always follow ESD prevention procedures when handling the product. Avoid applying excessive voltages to the power supply terminals or signal inputs or outputs, always connected to the load during the test on-going.

## Introduction to Magnetic Resonant Wireless Power Transfer

Recent technological advances in power semiconductors are enabling Wireless Power Transfer (WPT) as a technically and commercially viable option for charging and powering equipment across a wide range of markets, applications, and power levels.

Inductive charging has been in use for a number of years, however, it's burdened with limitations that restrict it to low power applications with tightly controlled alignment between the transmitter and receiver.

A more advantageous approach, magnetic resonant charging, addresses these shortcomings by using a high frequency oscillating magnetic field to transfer energy. The benefits that magnetic resonant charging offers include variable spacing between the transmitter and receiver, the ability to charge through materials such as a desk or an enclosure, one-to-many charging, ease of installation, suitability for high power levels, and fast charging. Table 1 provides a comparison between inductive charging and magnetic resonant charging.

GaN E-HEMTs are a key enabler of magnetic resonant charging because their extremely fast switching speeds, on the order of a few nanoseconds, result in very low switching losses. This allows them to operate efficiently at very high frequencies, such as the 6.78MHz that is commonly used for magnetic resonant charging.

**Table 1 A comparison of Inductive charging and Magnetic Resonant charging**

Charging technology	Inductive	Magnetic Resonant
Frequency range	80-300kHz	6.78MHz
Max transfer range	5mm	<b>50mm</b>
Multi-device	No	<b>Yes, at different power levels</b>
Spatial Freedom	Low	<b>High</b>
Power Range	Low & limited 30W max	<b>Broad &amp; versatile 50W to 20kW+</b>
Efficiency	Limited to 80%	<b>High: up to 95%</b>

A high-level block diagram of a resonant wireless power transfer system is shown in Figure 1. The transmit section is composed of a power amplifier, an impedance matching circuit and a transmit coil. High frequency energy is transferred wirelessly at 6.78MHz to the receive circuit which is comprised of a receive coil, an impedance matching circuit and a rectifier.

The GSWP100W-EVBPA evaluation board is designed to support and expedite the innovation of WPT systems by providing the Power Amplifier, the most challenging aspect of the system design.

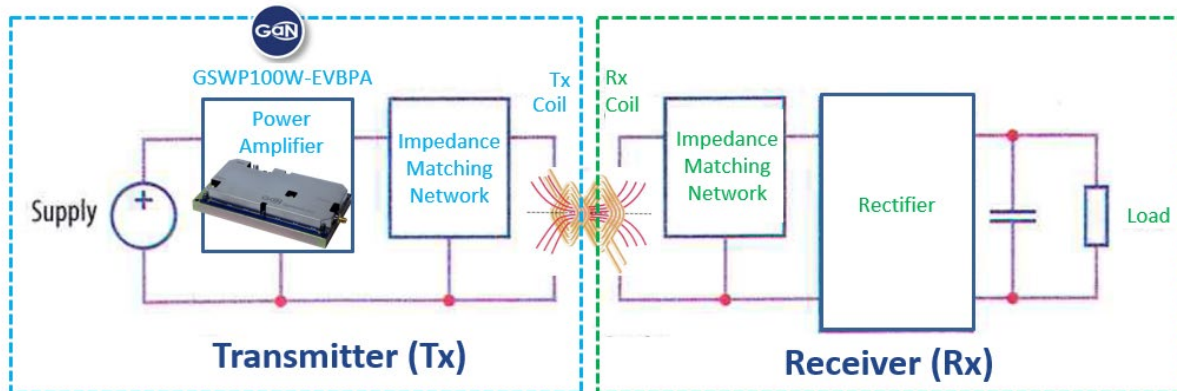

Figure 1 - A magnetic resonant wireless power transfer design.

## Evaluation board overview

The GSWP100W-EVBPA uses GaN Systems’ GS61008P E-HEMTs in a 6.78MHz class EF2 power amplifier. The GS61008Ps are used with the integrated high-speed pSemi PE29102 gate driver in a push-pull configuration. The outputs of the PE29102 are capable of providing switching transition speeds in the nano-seconds range for hard switching applications.

This Technical Manual includes a circuit description, a quick-start guide and measurement results.

## Evaluation Kit Contents and Requirements

### Kit Contents

The GSWP100W-EVBPA includes the following hardware for evaluating the GaN E-HEMT 100W power amplifier.

Table 2 GSWP100W-EVBPA Evaluation Kit Contents

Quantity	Description
1	GaN E-HEMT GS61008P WPT PA evaluation board assembly
1	WPT PA heatplate
1	WPT PA EMC shield
2	2 pins DC cord

## Hardware Requirements

In order to evaluate the performance of the evaluation board, the following equipment is required:

- DC power supply 100V/15A
- TEK scope with current probe TCM0030A
- Fluke 87 multimeter for input current
- 50dB 500W attenuator as load
- Spectrum analyzer
- Power meter
- Thermal meter

## Evaluation Board Assembly Overview

The evaluation board (EVB) is assembled with two GS61008P E-HEMT transistors and two PE29102 GaN E-HEMT drivers. Headers are included for monitoring the signal input, signal output, power connections and detection monitoring signals. Probe points are included for waveform measurements. Provision has been made for a single, suitable heatsink to be fastened against the two E-HEMTs, using the two holes in the center of the bottom heatplate.



Figure 2 • Top side of GSWP100W-EVBPA Evaluation Board Assembly



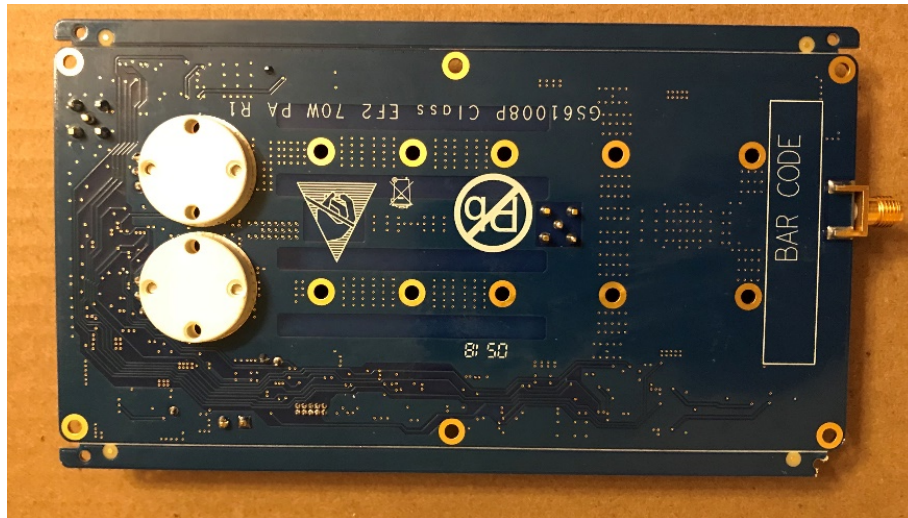

Figure 3 • Bottom side of GSWP100W-EVBPA Evaluation Board Assembly, showing copper coins



Figure 4 • GSWP100W-EVBPA Evaluation Board heatplate

## Block Diagram

The block diagram of the evaluation board is provided in Figures 5 through 7.

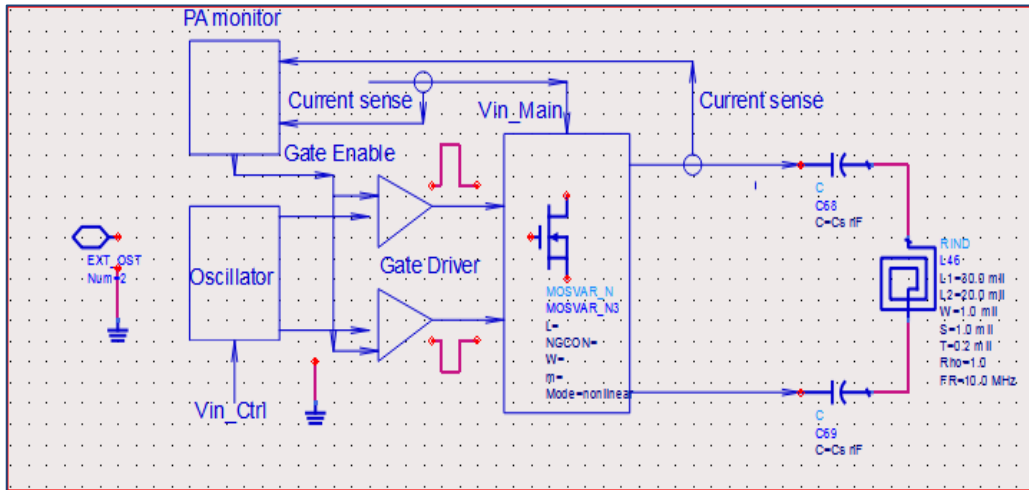

Figure 5 • GSWP100W-EVBPA WPT Push-Pull EVB Block Diagram

Note: The coil in Figure 5 is not included in the EVB.

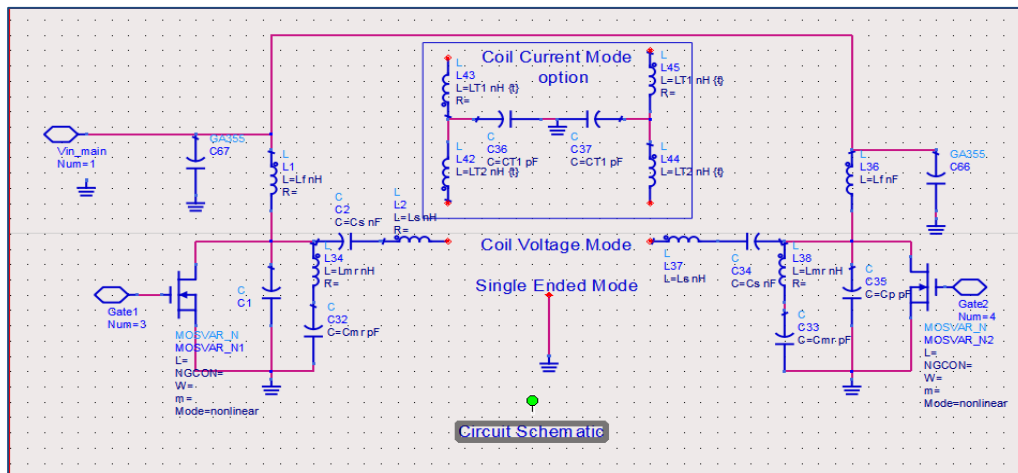

Figure 6 • GSWP100W-EVBPA WPT Class EF2 PA Block Diagram

Note: The switch devices are GaN Systems' GS61008P E-HEMTSs

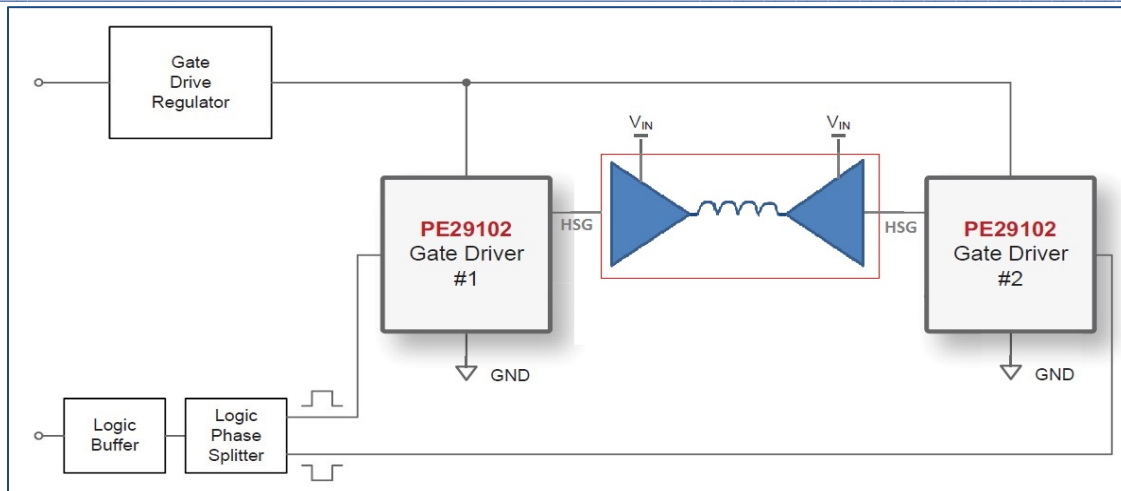

Figure 7 • GSWP100W-EVBPA WPT driver Block Diagram

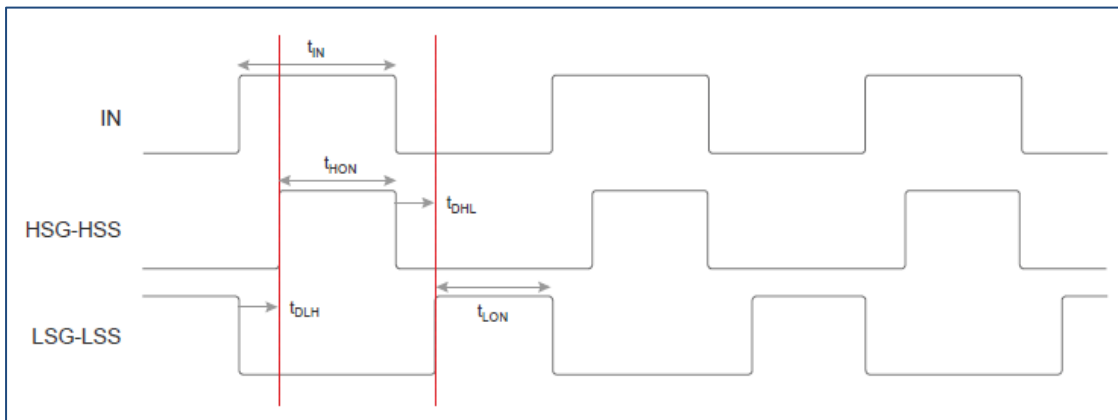

Figure 8 • PE29102 Dead-time Waveforms and Duty Cycle Setting

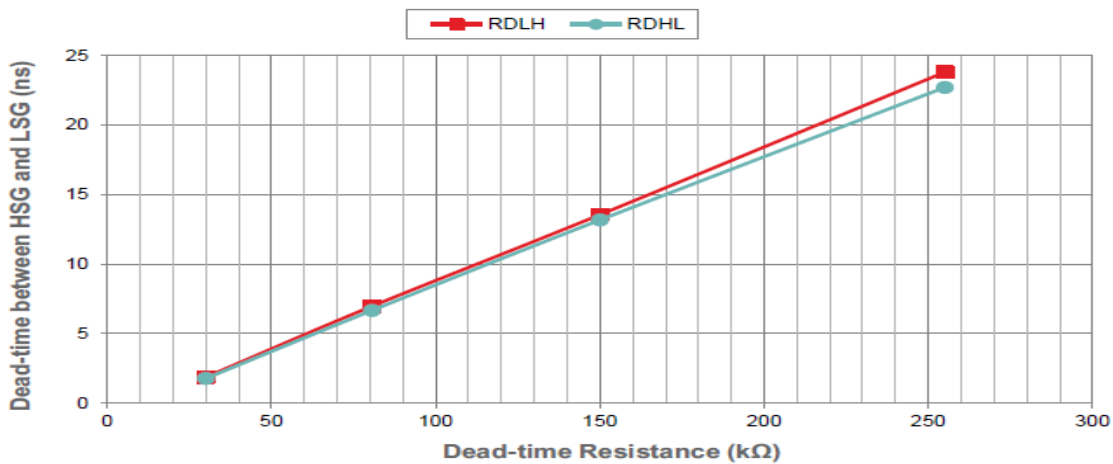

Figure 9 • Dead Time vs Dead Time Resistor



## Circuit Description

The Push-Pull circuit is comprised of two single ended PAs which share a common supply, however; the impedance matching and EMI filters are separated.

The high-side E-HEMTs are powered by a DC source, referred to as the HV supply. It is connected through J32. The voltage of this source not exceed  $33V_{DC}$ .

The low-voltage logic circuitry runs off a  $3.3V_{DC}$  voltage regulator, U88, which is powered from a  $+5V_{DC}$  source connected through JP35. The  $+5V_{DC}$  rail also feeds two PE29102 drivers U86 and U90, which are driven independently by U87, a common logic D-type flip/flop. U87 has a frequency divider configuration, which is driven by a crystal oscillator Y8 at a frequency of 13.56MHz. The two PE29102 gate drives are capable of 6V operation.

The PA can be configured to operate in a number of different modes, which include

- Push-pull configuration with an EMI filter
- Single ended mode
- Operation without an EMI filter
- Operation with an external oscillator signal input. Users can run multiple PAs together at the same frequency for high power operation.

Detailed operation procedures and setup for these alternative configurations are provided in the section titled “quick start guide”.

The PA includes an over-temperature protection circuit. Temperature sensor U9, placed close to the GS61008P E-HEMTs, monitors their temperature. In an over-temperature condition, the PE29102A driver will be disabled through U133 and stop driving the E-HEMTs. The design also includes circuitry to protect against over-current, and load mismatch.

The evaluation board includes an EMI filter, comprised of one low pass filter and one notch filter. The output of PA can be configured, through jumpers, to operate either with or without an EMI filter. The detailed jumper and SMA connector configurations are listed in Table 4

For convenience, test points are provided to monitor and measure the electrical signals. A description of the test points and diagram of their location is provided in Table 5.

The PA also includes a Micro Controller Unit (MCU) monitor interface header, J1. The signals available through J1 can be used to control the PA system for close loop in the WPT system. A definition of the signals available on header J1 is provided in Figure 10.

- Monitor signals on J1.
- Pin1: PA GND
- Pin2: 5V Input
- Pin3: output voltage detection
- Pin4: PA HV DC current
- Pin5: 3.3V DC
- Pin6: over voltage and current
- Pin7: output power detection
- Pin8: Temperature sensor voltage
- Pin9: PA HV DC input
- Pin10: Fan control enable

**Figure 10 • MCU interface definition. Signals on J1**

The PA connectivity is depicted in Figure 11 and includes the RF input and output, the DC biases and the MCU monitor interface.

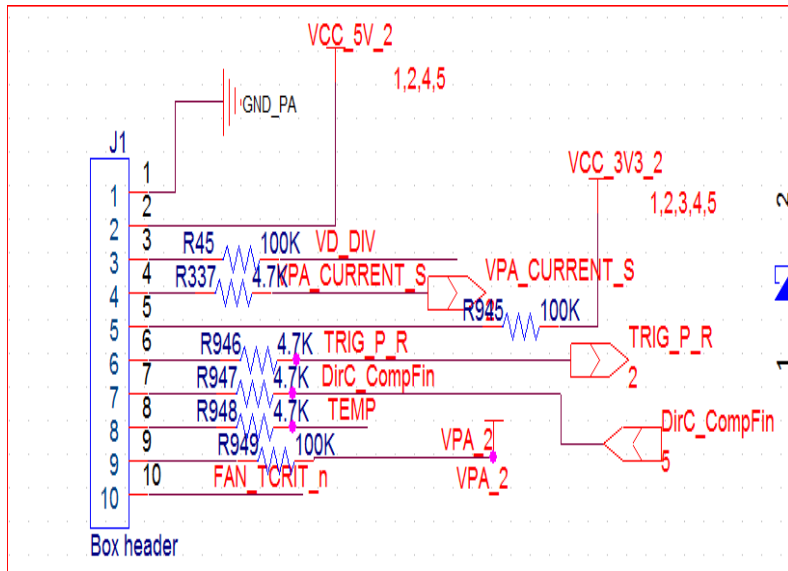

**Figure 11 • Circuit Connectivity**

## Protection Circuit

The PA includes circuitry to protect against input DC overcurrent, device over temperature, output RF overvoltage and Voltage Standing Wave Ratio (VSWR) protection. The protection signals are combined by U133, a 3 inputs OR gate logic chip, and will shut the driver down under a fault condition.

Input DC overcurrent protection (OCP): U91 is the DC current sensor chip, which can handle a maximum of 10A. The output of the current sensor ship is a current sense signal that goes thru buffer OP U122 and is compared to a reference voltage. The reference voltage is set with R101 and

R177. Upon an over current event, a signal is generated to signal OCP\_TRIG.

Overvoltage protection (OVP): The design includes overvoltage protection circuitry for both the high side and the low side. The high side voltage sensor is comprised of C276, C277, and two Schottky diodes; D52 and D44. C276/C277 form a voltage divider, the ratio of which can be changed. Two diodes rectify the RF signal to DC thru C278/C22 and R111 and the resulting voltage represents the high side output. The low side circuit is similar. It's comprised of C270, C280, and two diode D50, D53. These two voltage detection signals go to a two-channel comparator U68 and are combined with OR gate U70 into one overvoltage trigger, OVP\_TRIG.

The OVP and OCP go into a hard combine circuit D45, which a dual diode in one. To generate an overcurrent / overvoltage protection trigger signal.

Standing Wave Ratio (SWR) detection: two of coupler, T2, T83, comprise of the board band bidirectional coupler. The reflection signal goes thru D75, C722, C721, it turns into DC signal which goes thru the buffer OP U132 into comparator U130, of which the reference voltage is set by the R936/R937, the trigger point can be set by the reference voltage, which is refer the SWR. The direction of the coupler is around 15dB at 6.78MHz.

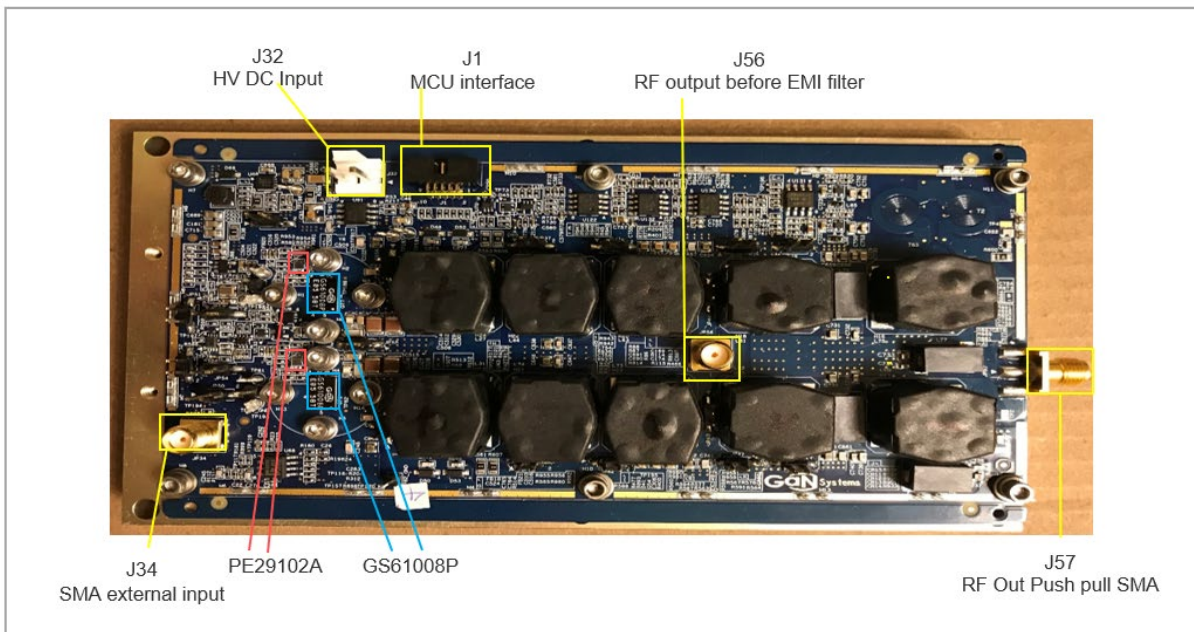

Figure 12 • Connectivity locations

## Thermal Management

Thermal management of the GaN E-HEMTs in this RF power system is a critical aspect of the design. Maintaining low device temperatures through proper thermal management enhances the system reliability and extends the range of operating temperature.

The GS61008P are bottom-side cooled devices that use GaN<sup>PX</sup>® packaging, designed for optimal

thermal performance. For effective thermal management, a hole is cut out of the PCB to permit access to the copper coins. The two GS61008Ps' bottom side thermal pads are soldered directly onto the copper coins on the bottom side of the PCB and the Gate, Drain and Source signals are routed on the top side of the PCB. This set up provides an ultra-low thermal impedance from the die to the copper coins.

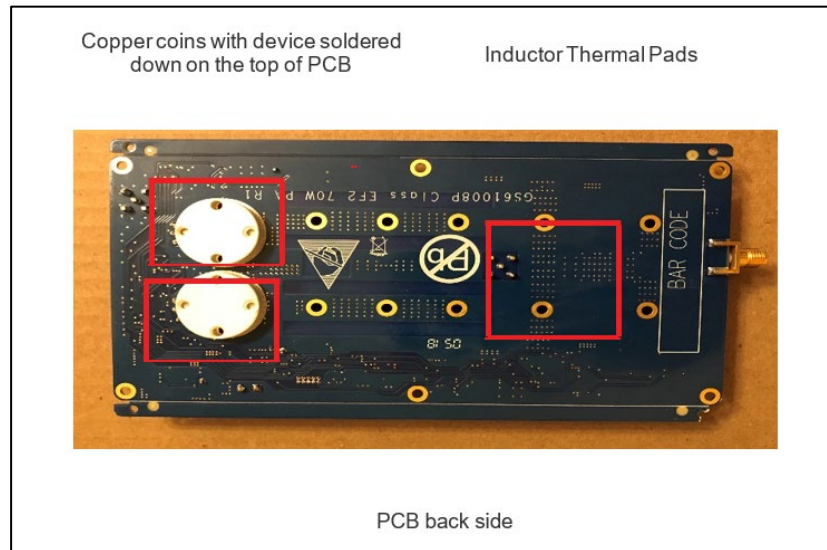

Figure 13 • Copper coins soldered beneath PCB and devices top PCB



Figure 14 • Aluminum heatplate with housing for two copper coins.

## Quick Start Guide

The GSWP100W-EVBPA EVB is designed to as a platform for evaluating the GS61008P E-HEMTs in a Push-Pull Class EF2 PA for WPT. This chapter will guide the user through the evaluation board overview, PA operation, bench setup and test results.

## Evaluation Board Overview

### Kit Contents

The GSWP100W-EVBPA evaluation kit contains:

- Power Amplifier evaluation board assembly
- PA heatplate
- PA EMC shield
- 2 pins DC cord

### Evaluation board specifications

**Table 3:** EVB specifications:

PARAMETER	SPECS
Input Voltage range	33V <sub>DC</sub> max
Tx output power	100W
Tx efficiency (peak)	88%
Topology/Class	EF2
Frequency	6.78 MHz
Switching type	Push/Pull
GaN Systems part number	GS61008P
Number of GS devices	2
Optimized RL (load)	30Ω
Constant current mode	optional

The maximum operating specifications of the evaluation board are as follows:

- Maximum HV supply input operating voltage of 33V<sub>DC</sub>
- Maximum LV supply input operating voltage of 7V<sub>DC</sub>
- Frequency of operation of 6.78MHz.
- Maximum output power of 100W \*

Note: \* The maximum output power depends on the input voltage, as shown in Figures 21 and 24.

### Configurations

The PA can be configured into three different operating options: voltage mode, current mode, and single ended. Table 4 describes how to configure the board using the jumpers provided.

**Table 4:** Configuration options

Jumper	Option	Jumper on/off
<b>JP51</b>	Internal oscillator (default)	JP51 on / JP52 off
<b>JP52</b>	External oscillator	JP51 off / JP52 on
<b>Voltage mode (without EMI filter)</b>	Voltage mode	JP42 off / JP44 off
<b>Current mode (with EMI filter)</b>	Current mode	JP43 off / JP44 on
<b>Voltage mode output</b>	RF output	JP56
<b>Current mode output</b>	RF output	JP57



**Test points**

To monitor the performance of PA, test points are provided and as described in Table 5. All test points are available on the top side of the board, none are on the bottom side. The test points locations are silkscreened on the PCB.

**Table 5: Test point description**

Test point	Description
TP197	U90 input (PE29102 driver)
TP76	U6 input (PE29102 driver)
TP8	Q77 Gate voltage
TP81	Q76 Gate voltage
TP189	Q77 Drain voltage
TP82	Q76 Drain voltage
TP176	60V DC current detection
TP194	External oscillator monitor

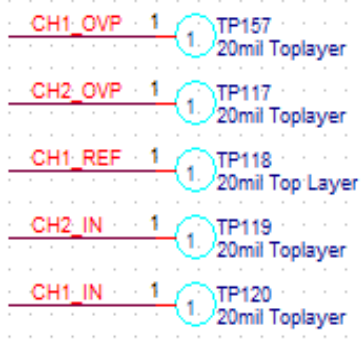

**Evaluation Bench Test Setup**

The test bench setup for the GSWP100W-EVBPA EVB is shown in Figure 15. Ensure that the safety precautions mentioned on page 2 are followed.

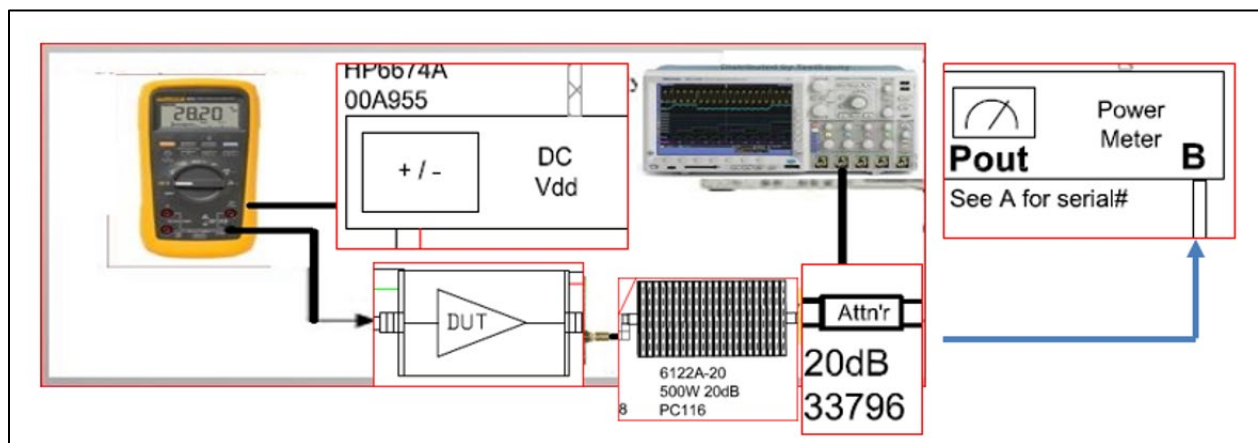

Figure 15 • Bench setup

A recommended list equipment is provided below. Equipment with equivalent performance specifications can be substituted. In all cases, ensure that it is well calibration.

- DC power supply 100V/15A
- TEK scope with current probe TCM0030A

- Fluke 87 multimeter for input current
- 50dB 500W attenuator as load
- Spectrum analyzer: RIGOL DSA 815
- Power meter: GiGa 8542C
- Thermal meter, sensor is located at screw of copper coin

Note: The WPT test setup is normally a non-50Ω system. If the PA is tested under a non-50Ω system, the measurement results may not correlate with 50Ω system due to the mismatch.

## Hardware Operation

The following steps provide a guideline for proper hardware operation and configuration.

- 1) First, set the current limit to 0.3A for the +5V<sub>DC</sub> supply feeding JP35.
- 2) Set the current limit to 1A for the HV DC supply feeding JP32 at a voltage of between +10V<sub>DC</sub> and +30V<sub>DC</sub>.
- 3) Verify that all DC power supplies are turned off.
- 4) Make sure the load is connected to JP56 or JP57.
- 5) Verify the Class EF2 waveform via test points TP8, TP81 with JP32 +5V<sub>DC</sub>.
- 6) Connect the V<sub>DD</sub> power supply to JP32. Apply between 4V to +10V<sub>DC</sub> to JP32. Read the output power at JP56 or JP57.
- 7) Turn on the HV supply to the desired value. Do not exceed the absolute maximum voltage of +33V<sub>DC</sub>. Keep the JP32 +5V<sub>DC</sub> on.
- 8) To power the evaluation board down, reverse the steps above.

## Measurement Technique

When measuring the high frequency content switch node, care must be taken to avoid long ground leads. Measure the switch node by placing the oscilloscope probe tip at JP192 and JP193 (designed for this purpose) or to the closest ground screws. Refer to Figure 16 for the proper probe technique.

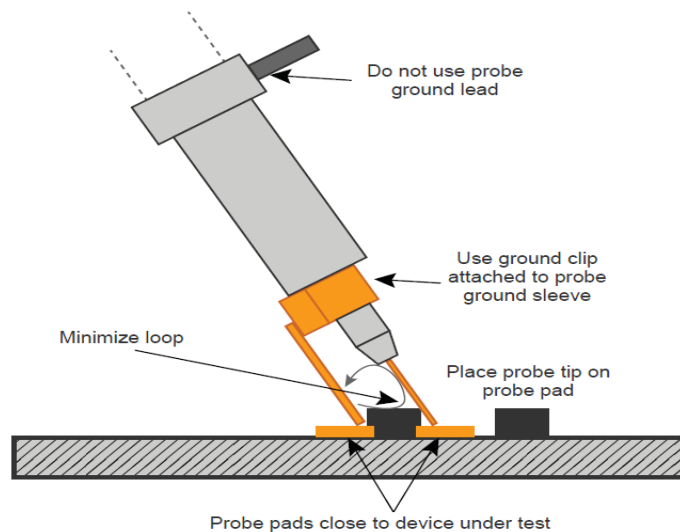

Figure 16 • Proper oscilloscope probe measurement technique

## PA Performance without EMI filter

### Power-on Procedure without EMI filter

- An additional heatsink may be required. The PA heatplate is provided with threaded hole locations that can be used to attach the heatsink to the heatplate with 4-40 screws. To ensure excellent thermal conduction, apply thermal grease to the PA / heatsink interface before screwing the units together. Enough thermal grease should be applied so that a small amount extrudes on all four sides as the screws are tightened. Wipe the assembly clean.
- Make sure jumpers JP43/JP44 are off
- Solder the wires with the SMA connector to JP56.
- Connector the load to JP56
- Plug the 5V<sub>DC</sub> supply into JP35. Pin 1: positive. Pin 2: negative. Turn the supply on and set the DC input voltage to 5V
- Plug the HV supply into JP32. Pin 1: positive. Pin 2: negative. Turn the supply on and ramp the voltage from 0V to 10V.
- Monitor the test point voltage by comparing the power meter measurement to GaN Systems' test data which is available in Appendix A.
- If the measurements correlate, increase the HV supply to 28V<sub>DC</sub>.
- **IMPORTANT:** Ensure the 5V<sub>DC</sub> supply does not exceed 6V during testing.

**Evaluation Results-without EMI filter**

The evaluation results for performance without an EMI filter are captured in Figures 17 through 21.

**Figure 17 • Oscilloscope Plot Showing Both GS61008P Gate Node Signals at TP8, TP81**

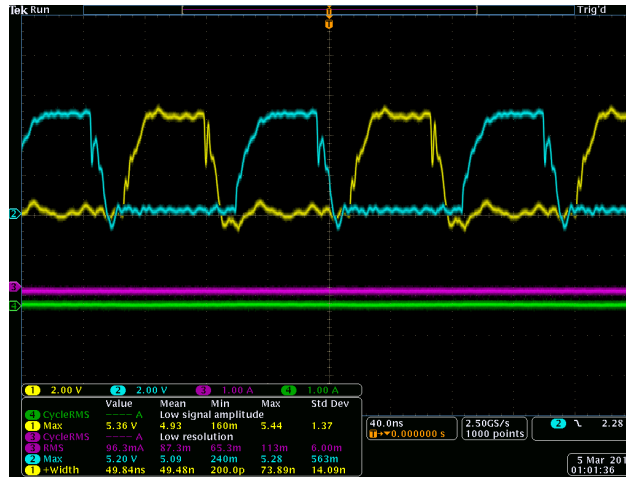

For a Class EF2 power amplifier topology, the optimal efficiency is achieved at a duty cycle of approximately 35%. At that operating point, the PA can work under very ZVS wide impedance range with high efficiency. The PA duty cycle is controlled by gate driver PE29102A. For a detailed time-delay design please refer to Figure 8 and Figure 9. The total resistor value of R955/R965 dominates the dead time of U86, and the delay time of U90 is controlled by R953/R952. Both two of PE29102A operate as high side mode, low side of chip is disable, and to reduce inductance thru shortened length of trace between gate of GS61008P and PE29102A, the pins of low side output of PE29102A are removed in the layout.

Typical waveforms at the devices Drain node are shown in Figure 18. Channel 1 is shown in yellow and channel 2 is shown in blue. At 31V<sub>DC</sub> input voltage, the output power is 100W before the EMI filter.

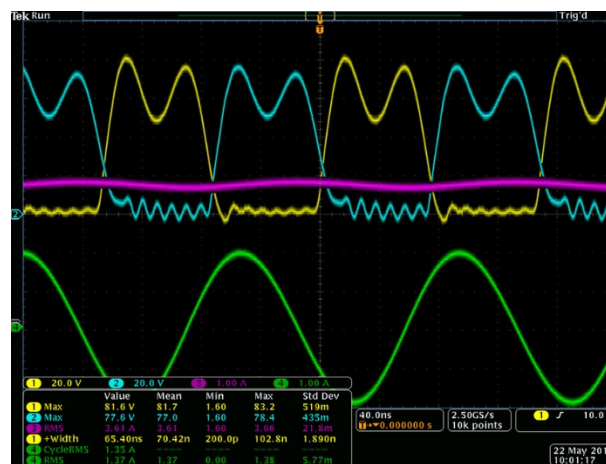

**Figure 18 • Oscilloscope Plot Showing Both GS61008P Drain Node Signals**

The ratio of maximum Drain voltage and input DC voltage is 2.33 which is ideal for a class EF2 amplifier. This operating condition eliminates voltage stress on the transistors and has low second harmonics. The output current shown in green, is not a perfect sinewave due to high order harmonics on the output load. Switch mode Power Amplifiers have a lot of harmonics at the output. One significant advantage of the Class EF2 topology is that it has a lower 2<sup>nd</sup> harmonic when compared to other PA topologies. This advantage results in a Class EF2 PA with much better EMI performance.

Figure 19 shows the spectrum of the PA at 100W output power without an EMI filter. Compared to the fundamental frequency, the 2<sup>nd</sup> harmonic is -35dBc, the 3<sup>rd</sup> harmonic is -20dBc, and the 4<sup>th</sup> harmonic is -34dBc. This extremely low 2<sup>nd</sup> harmonic performance makes it much easier to filter out the PA’s high order harmonic. This allows designers to meet EMI specifications and regulations without additional cost.

The PA’s output power and efficiency are shown in Figure 20. This PA delivers 93% efficiency at 100W output power and 27V<sub>DC</sub> input voltage. This remarkable efficiency performance makes PA the best candidate of the WPT systems, and particularly advantageous for high power applications such as drone, autonomous robot and E-bike charging.

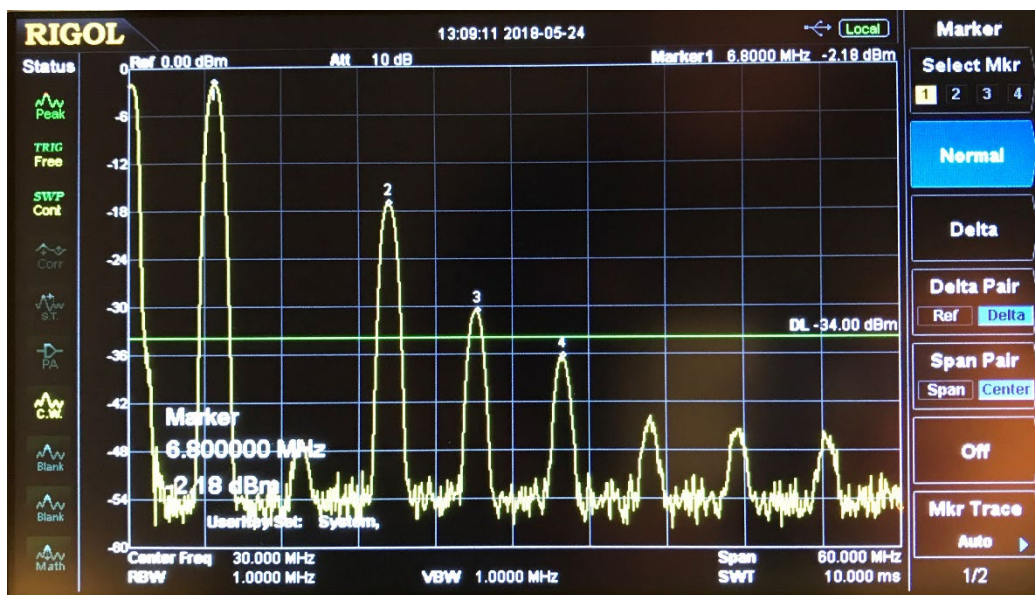
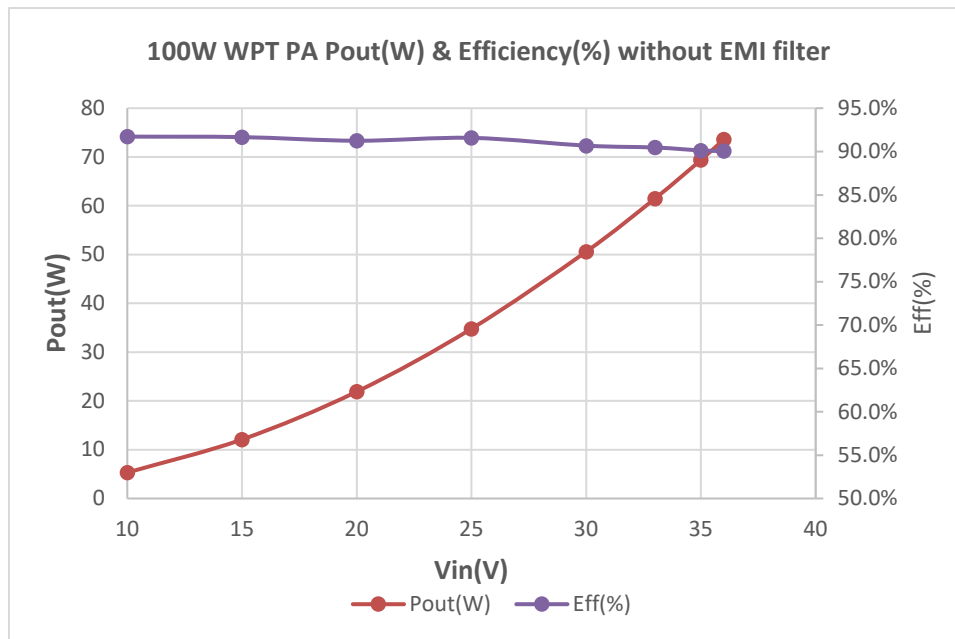

Figure 19 • Spectrum Plot of output terminal JP56 SMA after 49.66dB attenuation at 100W output power



**Figure 20 • Output power and efficiency of PA without EMI filter at JP56 SMA**

Note: With the EMI filter, the maximum power level is limited to 80W, due to the 50Ω test.

The PA’s system reliability is optimized when the temperature rise of each device is kept to a minimum, including that of the GaN E-HEMTs. The GS61008Ps are especially well suited in this regard, for a number of reasons. First, they have very low switching losses which allows them to operate at high efficiency and a low temperature rise at 6.78MHz, the common frequency used for resonant wireless power transfer. Secondly, the bottom-side cooled GaNPX® packaging provides an extremely low thermal impedance for efficient heat transfer to the heatsink, thereby drawing heat out of the device. This GaN based design is able to operate over a wide ambient temperature and with convection cooling, eliminating the need for cooling fans. These advantages support a PA design with excellent thermal performance up to 100W output power.

The temperature plot of the PA design was measured and captured with a SEEK thermal camera and is shown in Figure 21. The hottest devices are the first inductors, with the hottest inductor recording 35°C above ambient. The temperature rise of the GaN E-HEMTs, by comparison, is only 3°C. Because the GaN E-HEMTs run very cool, this allows operation over a very wide temperature range and extends operation to a higher power level while simultaneously simplifying the cooling system design and reducing the cost.



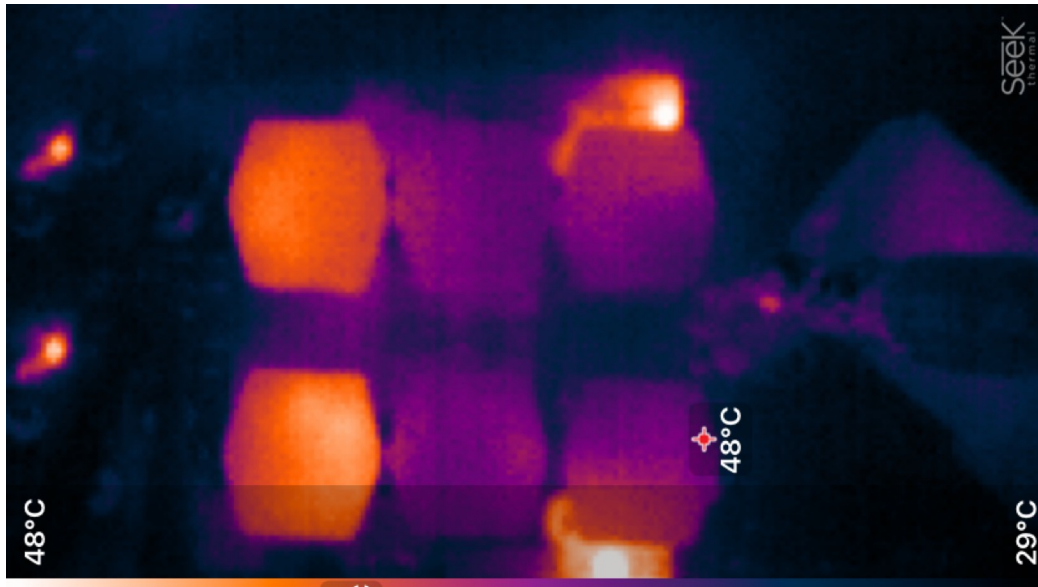

Figure 21 • Thermal measurement of PA without EMI filter at 100W output power

## PA Performance with EMI filter

### Power-on Procedure with EMI filter

- An additional heatsink may be required. The PA heatplate is provided with threaded hole locations that can be used to attach the heatsink to the heatplate with 4-40 screws. To ensure excellent thermal conduction, apply thermal grease to the PA / heatsink interface before screwing the units together. Enough thermal grease should be applied so that a small amount extrudes on all four sides as the screws are tightened. Wipe the assembly clean.
- Make sure jumpers JP43/JP44 are on
- Do not attach a cable or wire to JP56.
- Connect the load to JP57.
- Plug 5V<sub>DC</sub> supply into JP35. Pin 1: positive. Pin 2: negative. Adjust the voltage to 5V.
- Plug the HV supply into JP32. Pin 1: positive. Pin 2: negative. Turn the supply on and ramp the voltage from 0V to 10V
- Monitor the test point voltage by comparing the power meter measurement to GaN Systems' test data which is available in Appendix A.
- If the measurements correlate, increase the HV supply to 28V<sub>DC</sub>.
- **IMPORTANT:** Ensure the 5V<sub>DC</sub> supply does not exceed 6V during testing.
- The optimized impedance of the current mode PA is around 30Ω. Using a 50Ω load will not cause damage, however, the system will operate at a lower efficiency.

### Evaluation Results-with EMI filter

For improved EMI performance, a filter can be used to reduce the higher order harmonics in each side of the push-pull arm. Also, the addition of an EMI filter converts the PA from operating in voltage mode to current mode, which provides a constant current for the WPT system.

The frequency spectrum of the PA is depicted in Figure 22. The 3rd harmonic rejection is around -58dBc, with more than -60dBc rejection on high order harmonics. This outstanding performance will greatly help the WPT system level EMI performance.

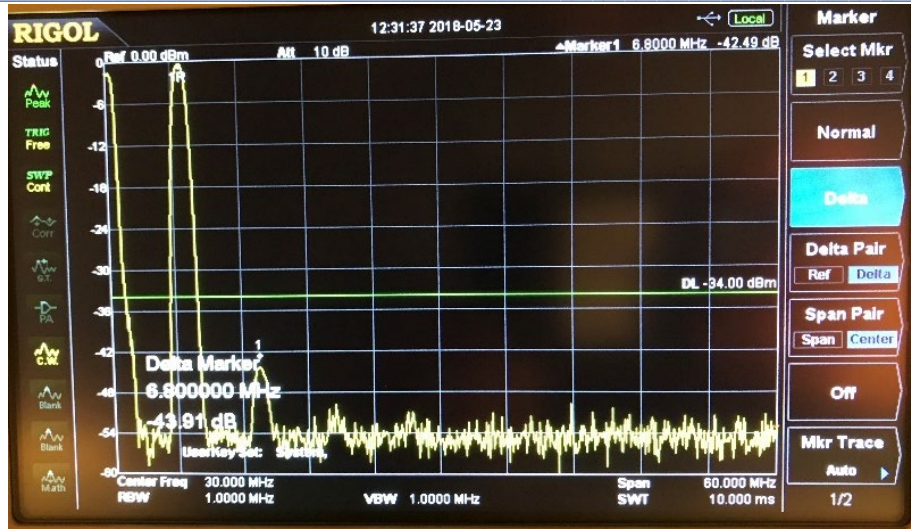

Figure 22 • Spectrum plot of output terminal JP57 SMA after 49.66dB attenuation at 100W output power  
The output power and efficiency with an EMI filter are shown in Figure 23. This PA design delivers 90% efficiency at 100W output power and 31V<sub>DC</sub> input voltage. This efficiency performance is lower than the one of without EMI filter due to the insertion and mismatch loss from the EMI filter. The design of EMI filter is optimal at 30 Ω, but the data is taken at 50 Ω.

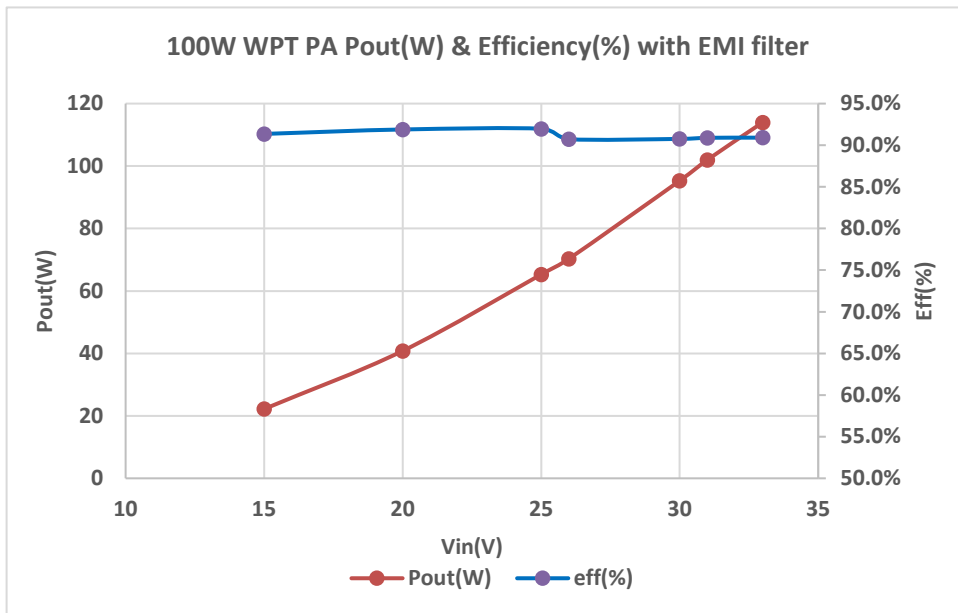

Figure 23 • GSWP100W-EVBPA power (W) and efficiency (%) plotted against input voltage at 50Ω load

The SEEK thermal camera photo of the PA is depicted in Figure 24. The thermal performance with EMI filter is very impressive. The hottest points of the circuit are the two 2<sup>nd</sup> harmonics shunt inductors which have a temperature rise of 35°C. The temperature rise of the GaN devices is a modest 3°C.

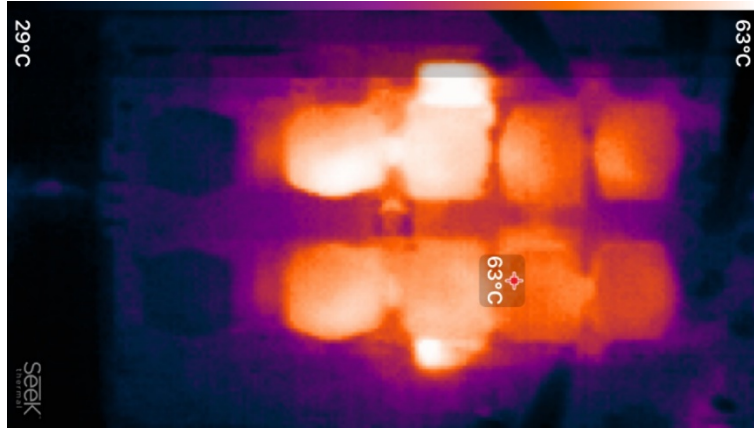

Figure 24 • Thermal measurement of PA with EMI filter at 100W output power

## Technical Resources

This document and additional technical resources are available for download from [www.gansystems.com](http://www.gansystems.com).

## Appendix A:

Sample Test Data with and without EMI filter

### Test Data with EMI filter

50Ω with 49.66dB attenuator

Vin(V)	Iin(A)	Pout(W)	Pin(W)	eff(%)
15	1.62	22.2	24.3	91.4%
20	2.22	40.8	44.4	91.9%
25	2.84	65.3	71.0	92.0%
26	2.98	70.3	77.5	90.7%
30	3.50	95.3	105.0	90.8%
31	3.62	102.0	112.2	90.9%
33	3.80	114.0	125.4	90.9%

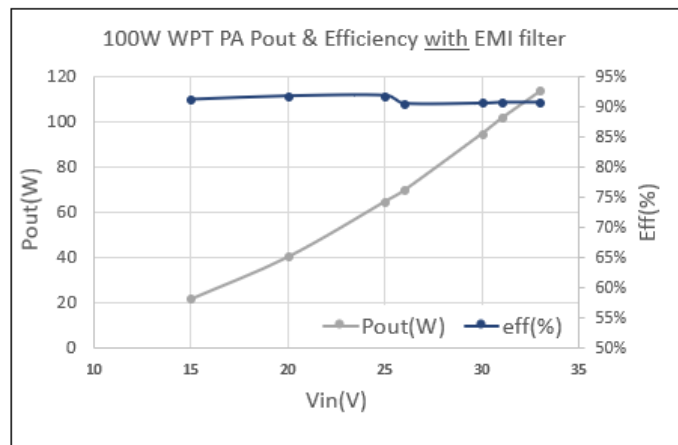

### Test Data without EMI filter

Vin(V)	Iin(A)	Pout(W)	Pin(W)	eff(%)
10	0.58	5.3	5.8	91.7%
15	0.88	12.1	13.2	91.7%
20	1.20	21.9	24.0	91.3%
25	1.52	34.8	38.0	91.6%
30	1.86	50.6	55.8	90.7%
33	2.06	61.5	68.0	90.5%
35	2.20	69.4	77.0	90.1%
36	2.27	73.6	81.7	90.1%

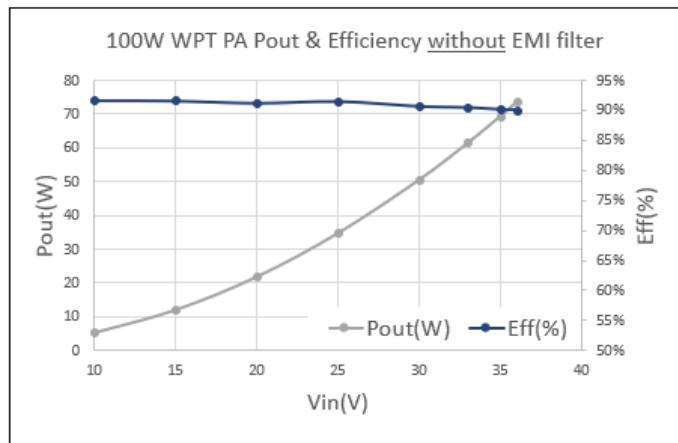

### Evaluation Board/kit Important Notice

GaN Systems Inc. (GaN Systems) provides the enclosed product(s) under the following **AS IS** conditions:

This evaluation board/kit being sold or provided by GaN Systems is intended for use for **ENGINEERING DEVELOPMENT, DEMONSTRATION, and OR EVALUATION PURPOSES ONLY** and is not considered by GaN Systems to be a finished end-product fit for general consumer use. As such, the goods being sold or provided are not intended to be complete in terms of required design-, marketing-, and/or manufacturing-related protective considerations, including but not limited to product safety and environmental measures typically found in end products that incorporate such semiconductor components or circuit boards. This evaluation board/kit does not fall within the scope of the European Union directives regarding electromagnetic compatibility, restricted substances (RoHS), recycling (WEEE), FCC, CE or UL, and therefore may not meet the technical requirements of these directives, or other related regulations.

If this evaluation board/kit does not meet the specifications indicated in the Technical Manual, the board/kit may be returned within 30 days from the date of delivery for a full refund. **THE FOREGOING WARRANTY IS THE EXCLUSIVE WARRANTY MADE BY THE SELLER TO BUYER AND IS IN LIEU OF ALL OTHER WARRANTIES, EXPRESSED, IMPLIED, OR STATUTORY, INCLUDING ANY WARRANTY OF MERCHANTABILITY OR FITNESS FOR ANY PARTICULAR PURPOSE. EXCEPT TO THE EXTENT OF THIS INDEMNITY, NEITHER PARTY SHALL BE LIABLE TO THE OTHER FOR ANY INDIRECT, SPECIAL, INCIDENTAL, OR CONSEQUENTIAL DAMAGES.**

The user assumes all responsibility and liability for proper and safe handling of the goods. Further, the user indemnifies GaN Systems from all claims arising from the handling or use of the goods. Due to the open construction of the product, it is the user's responsibility to take any and all appropriate precautions with regard to electrostatic discharge.

No License is granted under any patent right or other intellectual property right of GaN Systems whatsoever. **GaN Systems assumes no liability for applications assistance, customer product design, software performance, or infringement of patents or any other intellectual property rights of any kind.**

GaN Systems currently services a variety of customers for products around the world, and therefore this transaction **is not exclusive**.

**Please read the Technical Manual and, specifically, the Warnings and Restrictions notice in the Technical Manual prior to handling the product.** Persons handling the product(s) must have electronics training and observe good engineering practice standards.

This notice contains important safety information about temperatures and voltages. For further safety concerns, please contact a GaN Systems' application engineer.



In Canada:

GaN Systems Inc.  
1145 Innovation Drive Suite 101  
Ottawa, Ontario, Canada K2K 3G8  
T +1 613-686-1996

In Europe:

GaN Systems Ltd., German Branch  
Terminalstrasse Mitte 18,  
85356 München, Germany  
T +49 (0) 8165 9822 7260

In the United States:

GaN Systems Corp.  
2723 South State Street, Suite 150,  
Ann Arbor, MI. USA 48104  
T +1 248-609-7643

**[www.gansystems.com](http://www.gansystems.com)**

**Important Notice** – Unless expressly approved in writing by an authorized representative of GaN Systems, GaN Systems components are not designed, authorized or warranted for use in lifesaving, life sustaining, military, aircraft, or space applications, nor in products or systems where failure or malfunction may result in personal injury, death, or property or environmental damage. The information given in this document shall not in any event be regarded as a guarantee of performance. GaN Systems hereby disclaims any or all warranties and liabilities of any kind, including but not limited to warranties of non-infringement of intellectual property rights. All other brand and product names are trademarks or registered trademarks of their respective owners. Information provided herein is intended as a guide only and is subject to change without notice. The information contained herein or any use of such information does not grant, explicitly, or implicitly, to any party any patent rights, licenses, or any other intellectual property rights. General Sales and Terms Conditions apply.

© 2009-2020 GaN Systems Inc. All rights reserved.

## X-ON Electronics

Largest Supplier of Electrical and Electronic Components

*Click to view similar products for [Power Management IC Development Tools](#) category:*

*Click to view products by [Gan Systems](#) manufacturer:*

Other Similar products are found below :

[EVAL-ADM1168LQEBZ](#) [EVB-EP5348UI](#) [MIC23451-AAAYFL EV](#) [MIC5281YMME EV](#) [DA9063-EVAL](#) [ADP122-3.3-EVALZ](#) [ADP130-0.8-EVALZ](#) [ADP130-1.2-EVALZ](#) [ADP130-1.5-EVALZ](#) [ADP130-1.8-EVALZ](#) [ADP1714-3.3-EVALZ](#) [ADP1716-2.5-EVALZ](#) [ADP1740-1.5-EVALZ](#) [ADP1752-1.5-EVALZ](#) [ADP1828LC-EVALZ](#) [ADP1870-0.3-EVALZ](#) [ADP1871-0.6-EVALZ](#) [ADP1873-0.6-EVALZ](#) [ADP1874-0.3-EVALZ](#) [ADP1882-1.0-EVALZ](#) [ADP199CB-EVALZ](#) [ADP2102-1.25-EVALZ](#) [ADP2102-1.875EVALZ](#) [ADP2102-1.8-EVALZ](#) [ADP2102-2-EVALZ](#) [ADP2102-3-EVALZ](#) [ADP2102-4-EVALZ](#) [ADP2106-1.8-EVALZ](#) [ADP2147CB-110EVALZ](#) [AS3606-DB](#) [BQ24010EVM](#) [BQ24075TEVM](#) [BQ24155EVM](#) [BQ24157EVM-697](#) [BQ24160EVM-742](#) [BQ24296MEVM-655](#) [BQ25010EVM](#) [BQ3055EVM](#) [NCV891330PD50GEVB](#) [ISLUSBI2CKIT1Z](#) [LM2744EVAL](#) [LM2854EVAL](#) [LM3658SD-AEV/NOPB](#) [LM3658SDEV/NOPB](#) [LM3691TL-1.8EV/NOPB](#) [LM4510SDEV/NOPB](#) [LM5033SD-EVAL](#) [LP38512TS-1.8EV](#) [EVAL-ADM1186-1MBZ](#) [EVAL-ADM1186-2MBZ](#)