

CUSTOMER _____

CUSTOMER' S P/N _____

DESCRIPTION DIP Power Inductor

SGTE PART NO. GPDB1009-4R7M

SAMPLE NO. S16010901 REVISION NO. A0 DATE 2016/1/9

SPECIFICATION FOR APPROVAL

FULLY APPROVED	REVISE APPROVED

SGTE 感通科技

深圳感通科技有限公司（大陸工廠）

GANTONG TECHNOLOGY (SHENZHEN) CO., LTD.

深圳市平湖街道平湖村萬福路26號

No.26 Wan fu Road, Ping hu Village. Ping hu town, Shenzhen City.

Tel: 0755-28457600

Fax: 0755-28452952

感通科技有限公司（台灣辦事處）

臺北縣汐止市新台5路一段77號10樓之7

10F~7, NO.77, Sec.1, Hsin Tai 5 Road, Shi-chi City, Taipei.

Tel: 886-2-8698-2341

Fax:886-2-8698-2342

納美科技股份有限公司（香港辦事處）

LAPEE TECHNOLOGY LIMITED

香港九龍尖沙嘴加連威老道嘉蘭圍5-11號利時商業大廈17樓1713室

Room 1713 17/F, Rise Commercial Bldg5-11 Granville Cri cuit, Granville Rd, TSim Sha Tsui., Kln

Tel: 852-25301111

Fax: 852-25371111

<http://www.szgte.com>

SPECIFICATION

RoHS
COMPLIANT

Customers Part Number	Item Name	Date	
	DIP Power Inductor	2016/1/9	
Gan Tong Part NO.	Sample NO.	Revision No.	A0
GPDB1009-4R7M	S16010901	Page	1-5

MECHANICAL & DIMENSIONS

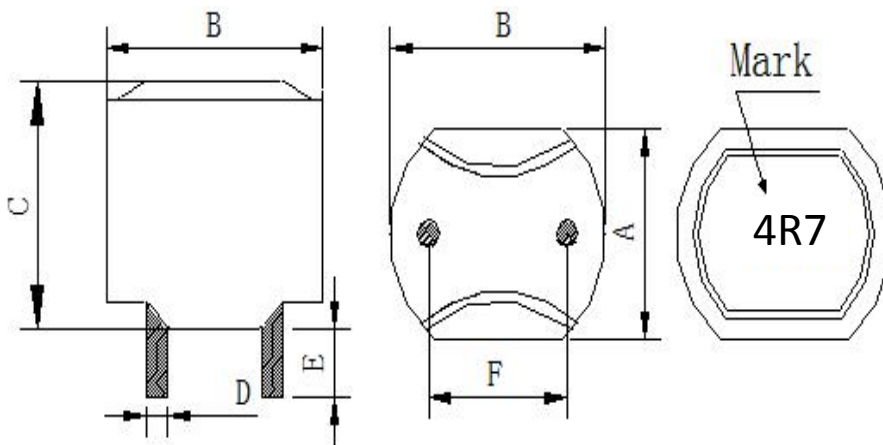

(UNIT: mm)	
A	9.0 ± 0.5
B	10.0 ± 0.5
C	10.5 Max
D	0.8 ± 0.1
E	3.4 ± 0.5
F	6.0 ± 0.5

CIRCUIT

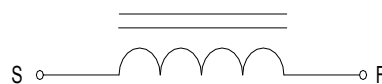

ELECTRICAL REQUIREMENTS:

PARAMETER	SPECIFICATION	CONDITION	TEST INSTRUMENTS
L	$4.7 \pm 20\%$ uH	100KHz/1V	■ LCR Agilent4284A / Chroma 11300
DCR	9 max mΩ	@ 25°C	■ CH16502 IMPEDANCE METER
I-sat	16.0 A mps	$\cong 65\%L0A$	■ A4284A+A42841A LCR METER
I rms	12.0 A mps	$\Delta T \leq 40^\circ C$	■ Chroma /11300+3302+1320+1320S

- I rms: Current that causes a 40°C temperature rise from 25°C ambient.
- I sat: DC current at which the inductance drops 35% from it' s value without current.
- All test Data is referenced to 25°C ambient.
- Operating Temperature Range: -25°C to +125°C.

SPECIFICATION

RoHS
COMPLIANT

Customers Part Number	Item Name	Date	
	DIP Power Inductor	2016/1/9	
Gan Tong Part NO.	Sample NO.	Revision No.	A0
GPDB1009-4R7M	S16010901	Page	2-5

Electrical Characteristic :

PARAMETER	L	DCR	I-sat	Irms	
UNIT	uH	mΩ	A mps	A mps	
SPECIFICATION	4.7 ± 20%	9 max	16.0	12.0	
CONDITION	100KHz/1V	@ 25°C	≧ 65%LOA	ΔT ≦ 40°C	
1	4.91	7.71	76.70%	25°C	
2	4.78	7.79			
3	4.59	7.66			
4	4.77	7.83			
5	4.69	7.55			
6	4.83	7.66			
7	4.92	7.99			
8	4.88	7.55			
9	4.66	7.61			
10	4.79	7.55			
MEAN	4.78	7.69			
R	0.33	0.44			

External Dimensions:

NO	A	B	C	D	E	F		
	9.0± 0.5	10.0± 0.5	10.5 Max	0.8± 0.1	3.4± 0.5	6.0± 0.5		
1	8.97	9.95	9.37	0.79	3.36	5.98		
2	8.98	9.96	9.38	0.81	3.38	6.03		
3	8.95	9.98	9.35	0.82	3.35	6.00		
4	9.00	9.95	9.30	0.77	3.45	5.98		
5	9.00	10.01	9.40	0.81	3.40	5.95		
6	9.01	9.99	9.35	0.80	3.41	6.02		
7	8.96	9.95	9.45	0.75	3.38	6.00		
8	8.99	9.98	9.35	0.79	3.42	6.03		
9	9.00	10.20	9.40	0.78	3.44	5.98		
10	8.98	9.97	9.38	0.81	3.41	5.95		
MEAN	8.98	9.99	9.37	0.79	3.40	5.99		
R	0.06	0.25	0.15	0.07	0.10	0.08		

Inductance measured at 100KHz/1Vrms..

Electrical specifications at 25±5°C. Humidity 60±10%

SPECIFICATION

RoHS
COMPLIANT

Customers Part Number	Item Name	Date	
	DIP Power Inductor	2016/1/9	
Gan Tong Part NO.	Sample NO.	Revision No.	A0
GPDB1009-4R7M	S16010901	Page	3-5

INDUCTANCE (uH) / TEMPERATURE RISE(°C) VS DC BIAS (Amps)

IDC	L(uH)	L/LoA (%)	T(°C)	ΔT(°C)		
0.0 A	4.93	100.00%	25.0	0.0		
2.0 A	4.90	99.39%	26.6	1.6		
4.0 A	4.77	96.75%	28.8	3.8		
6.0 A	4.64	94.12%	31.5	6.5		
8.0 A	4.48	90.87%	36.3	11.3		
10.0 A	4.30	87.22%	42.0	17.0		
12.0 A	4.12	83.57%	50.0	25.0		
14.0 A	3.95	80.12%	63.8	38.8		
16.0 A	3.78	76.67%	80.5	55.5		
18.0 A	3.61	73.23%	97.6	72.6		
20.0 A	3.41	69.17%	117.5	92.5		

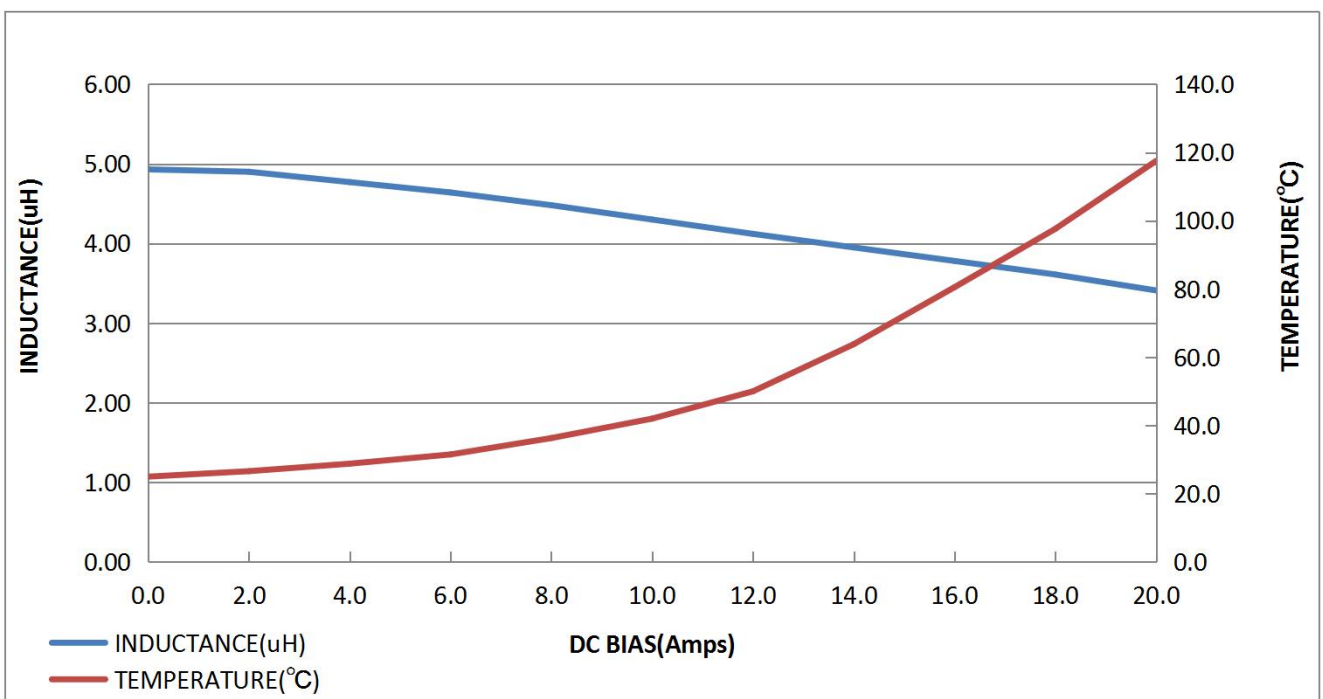

SPECIFICATION

RoHS
COMPLIANT

Customers Part Number	Item Name	Date	
	DIP Power Inductor	2016/1/9	
Gan Tong Part NO.	Sample NO.	Revision No.	A0
GPDB1009-4R7M	S16010901	Page	4-5

PACKAGING

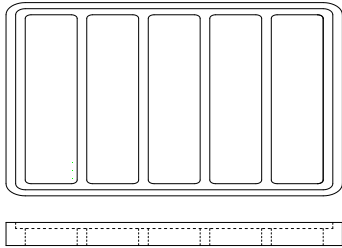

PET Size : 215*148*16mm

Quantity :130PCS/PET

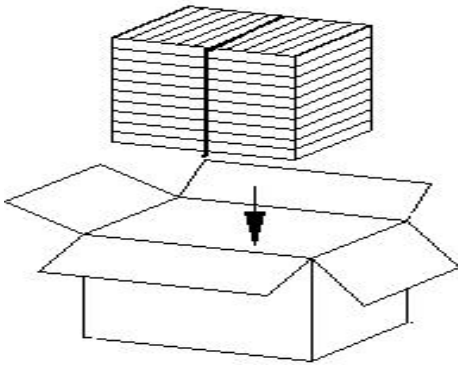

Small box Size : 238*156*165 mm

Quantity : 10PET/Small box

1Small box/1300PCS

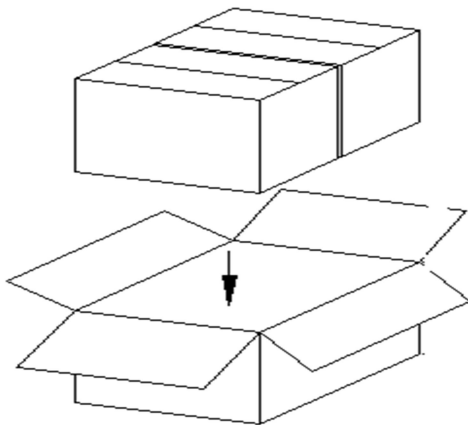

Big box Size : 328*251*175mm

Quantity : 2 Small box/Big box

1 Big box/2600PCS

Storage

1. Temperature and humidity conditions: Less than 40°C and 70% RH.
2. Recommended products should be used within 6 months form the time of delivery.
3. The packaging material should be kept where no chlorine or sulfur exists in the air.

Transportation

1. Products should be handled with care to avoid damage or contamination from perspiration and skin oils.
2. The use of tweezers or vacuum pick up is strongly recommended for individual components.
3. Bulk handling should ensure that abrasion and mechanical shock are minimized.

SPECIFICATION

**RoHS
COMPLIANT**

Customers Part Number	Item Name	Date	
	DIP Power Inductor	2016/1/9	
Gan Tong Part NO.	Sample NO.	Revision No.	A0
GPDB1009-4R7M	S16010901	Page	5-5

SOLDRING CONDITIONS

Figure 1. Re-flow Soldering

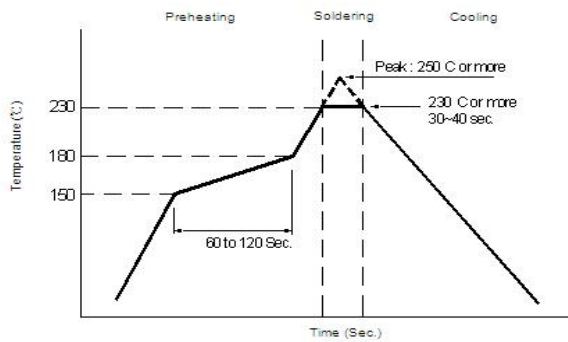
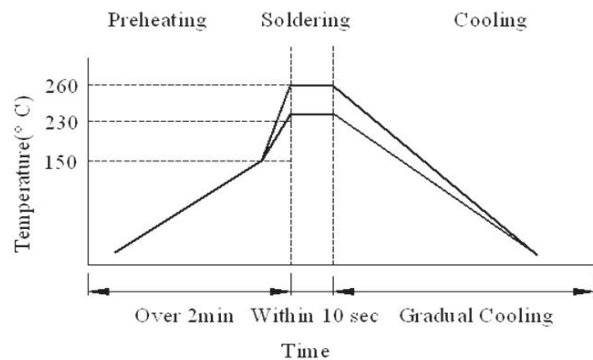

Figure 2. Wave Soldering



Soldering Iron: temperature $350^{\circ}\text{C} \pm 10^{\circ}\text{C}$, dwell time shall be less than 3 sec.

Reliability and Testing Conditions/Surface Mount Type Power Inductors

Item	Specification	Conditions															
Solderability	More than 90% of the terminal electrode should be covered with solder.																
Solder Heat Resistance	Inductance within $\pm 20\%$ of initial value and appearance shall not break.																
Heat resistance	Inductance within $\pm 20\%$ of initial value. No disconnection or short circuit. Appearance shall not break.	After 500 ± 12 hours in $145 \pm 5^{\circ}\text{C}$ and 2 hour drying under normal condition.															
Cold resistance	Inductance within $\pm 20\%$ of initial value. No disconnection or short circuit. Appearance shall not break.	After 500 ± 12 hours in $-40 \pm 2^{\circ}\text{C}$ and 2 hour drying under normal condition.															
Thermal shock	Inductance within $\pm 20\%$ of initial value. No disconnection or short circuit. Appearance shall not break.	After 10 cycles of following condition. <table border="1" style="margin-left: auto; margin-right: auto;"> <thead> <tr> <th>Step</th> <th>Temperature ($^{\circ}\text{C}$)</th> <th>Times (min.)</th> </tr> </thead> <tbody> <tr> <td>1</td> <td>-40 ± 2</td> <td>30</td> </tr> <tr> <td>2</td> <td>Room Temperature</td> <td>Within 3</td> </tr> <tr> <td>3</td> <td>145 ± 5</td> <td>30</td> </tr> <tr> <td>4</td> <td>Room Temperature</td> <td>Within 3</td> </tr> </tbody> </table>	Step	Temperature ($^{\circ}\text{C}$)	Times (min.)	1	-40 ± 2	30	2	Room Temperature	Within 3	3	145 ± 5	30	4	Room Temperature	Within 3
Step	Temperature ($^{\circ}\text{C}$)	Times (min.)															
1	-40 ± 2	30															
2	Room Temperature	Within 3															
3	145 ± 5	30															
4	Room Temperature	Within 3															
Humidity Resistance	Inductance within $\pm 20\%$ of initial value. No disconnection or short circuit. Appearance shall not break.	After 500 ± 12 hours in $40 \pm 2^{\circ}\text{C}$ and 90 to 95% humidity , and 2 hour drying under normal condition.															
* Vibration Test	Inductance within $\pm 20\%$ of initial value and appearance shall not break.	After vibration for 1hour, In each of three orientations at sweep vibration ($10 \sim 55 \sim 10\text{Hz}$) with 1.52mm P-P Amplitudes.															

X-ON Electronics

Largest Supplier of Electrical and Electronic Components

Click to view similar products for [Fixed Inductors](#) category:

Click to view products by [Gantong](#) manufacturer:

Other Similar products are found below :

[CR32NP-151KC](#) [CR32NP-180KC](#) [CR32NP-181KC](#) [CR32NP-1R5MC](#) [CR32NP-390KC](#) [CR32NP-3R9MC](#) [CR32NP-680KC](#) [CR32NP-820KC](#) [CR32NP-8R2MC](#) [CR43NP-390KC](#) [CR43NP-560KC](#) [CR43NP-680KC](#) [CR54NP-181KC](#) [CR54NP-470LC](#) [CR54NP-820KC](#) [CR54NP-8R5MC](#) [70F224AI](#) [MGDQ4-00004-P](#) [MHL1ECTTP18NJ](#) [MHQ1005P10NJ](#) [MHQ1005P1N0S](#) [MHQ1005P2N4S](#) [MHQ1005P3N6S](#) [MHQ1005P5N1S](#) [MHQ1005P8N2J](#) [PE-51506NL](#) [PE-53601NL](#) [PE-53602NL](#) [PE-53630NL](#) [PE-53824SNLT](#) [PE-92100NL](#) [PG0434.801NLT](#) [PG0936.113NLT](#) [9220-20](#) [9310-16](#) [PM06-2N7](#) [PM06-39NJ](#) [A01TK](#) [1206CS-471XJ](#) [HC2LP-R47-R](#) [HC2-R47-R](#) [HC3-2R2-R](#) [HCF1305-3R3-R](#) [1206CS-151XG](#) [RCH664NP-140L](#) [RCH664NP-4R7M](#) [RCH8011NP-221L](#) [RCP1317NP-332L](#) [RCP1317NP-391L](#) [RCR1010NP-470M](#)