

PRODUCT SPECIFICATION

Part Number	MEM2067	Rev	A	Date	11/09/14		
Product Description	Micro SD Memory Card Connector, SMT, Hinged, 1.80mm Profile.				Page	1	
Doc Number	MEM2067	Prepared	AO	Checked	ST	Approved	VJ

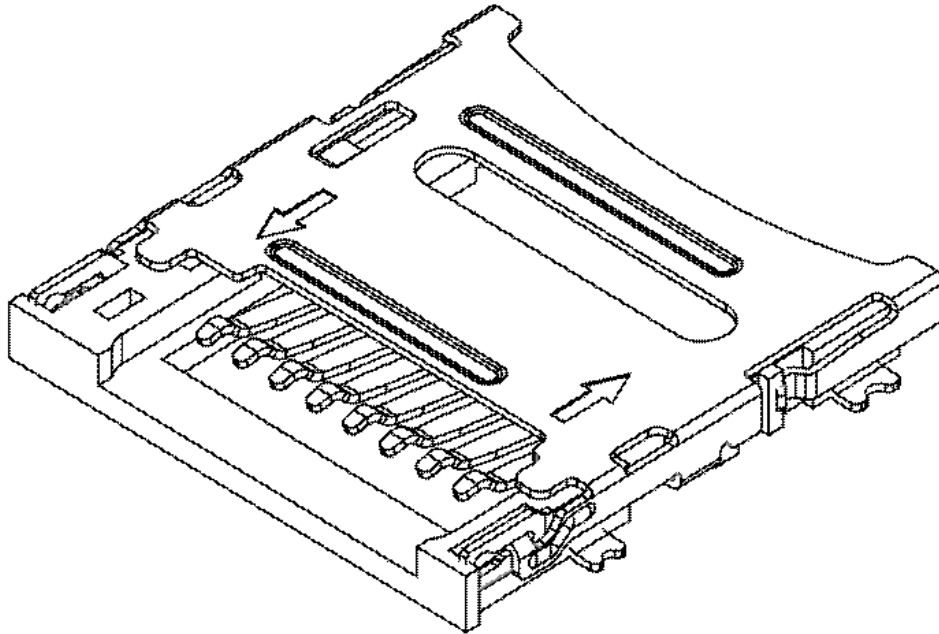

PRODUCT SPECIFICATION

Part Number	MEM2067	Rev	A	Date	11/09/14
Product Description	Micro SD Memory Card Connector, SMT, Hinged, 1.80mm Profile.			Page	2
Doc Number	MEM2067	Prepared	AO	Checked	ST
				Approved	VJ

1.0 SCOPE.

This specification covers the Micro SD Memory Card Connector, SMT, MEM2067 series. (Hinged Type, SMT, 1.80mm profiles).

2.0 PRODUCT NAME AND PART NUMBER.

Micro SD Memory Card Connector, Hinged Type: MEM2067

3.0 PRODUCT SHAPE, DIMENSIONS AND MATERIAL.

Please refer to drawings.

4.0 RATINGS.

- 4.1 Current rating 1.0A AC/DC
- 4.2 Voltage rating 100 V AC/DC
- 4.3 Operating Temperature Range -40°C to +85°C
- 4.4 Humidity 95% R.H. Max.

5.0 TEST AND MEASUREMENT CONDITIONS.

Product is designed to meet electrical, mechanical and environmental performance requirements specified in Paragraph 6.0. All tests are performed in ambient conditions unless otherwise specified.

6.0 PERFORMANCE.

Item	Test Condition	Requirement
Examination of Product	Visual, dimensional and functional inspection as per quality plan.	Product shall meet requirements of product drawing and specification.

PRODUCT SPECIFICATION

Part Number	MEM2067	Rev	A	Date	11/09/14
Product Description	Micro SD Memory Card Connector, SMT, Hinged, 1.80mm Profile.			Page	3
Doc Number	MEM2067	Prepared	AO	Checked	ST
		Approved	VJ		

6.1 Electrical Performance.

Item	Test Condition	Requirement
Contact Resistance	Mate dummy card and measure by dry circuit, 20mV Max. 10mA Max. In accordance with EIA-364-23	100mΩ max initial
Insulation Resistance	Apply 500V DC between adjacent pins or pin and ground. In accordance with EIA-364-21	Greater than 1000MΩ
Dielectric Strength	Apply 500V AC for 1 minute between adjacent terminals and ground. In accordance with EIA-364-20.	No breakdown

6.2 Mechanical Performance.

Item	Test Condition	Requirement
Durability	Insertion and extraction are repeated for 5000 cycles with the actual card at the speed rate of 400-600 cycles/hour.	Contact Resistance: 100mΩ Max. Appearance: No damage
Temperature Rise	Mate card and measure the temperature rise of contact, when rated current is passed. In accordance with EIA-364-70 Method 1	Temperature rise: 30°C Max.
Vibration	Mate dummy card and subject to the following vibration conditions, for a period of 2 hours in each 3 mutually perpendicular axes. Amplitude: 1.52 mm P-P Frequency: 10-55-10 Hz Shall be traversed in 1 minute. In accordance with EIA 364-28	Appearance: No damage Contact Resistance: 100mΩ Max. Discontinuity: 1.0 μsec. Max.

PRODUCT SPECIFICATION

Part Number	MEM2067	Rev	A	Date	11/09/14
Product Description	Micro SD Memory Card Connector, SMT, Hinged, 1.80mm Profile.			Page	4
Doc Number	MEM2067	Prepared	AO	Checked	ST
				Approved	VJ

Item	Test Condition	Requirement
Mechanical Shock	Mate dummy card and subject to the following shock conditions. 3 shocks shall be applied along 3 mutually perpendicular axes. (total of 18 shocks). Test pulse: Half Sine Peak Value: 490m/s ² Duration: 11ms In accordance with EIA 364-27	Appearance: No damage Contact Resistance: 100mΩ Max. Discontinuity: 1.0 μsec. Max.
Temperature Cycling	Mate dummy card and subject to the following conditions for 5 cycles. Upon completion of the test exposure period, the test specimens shall be conditioned at ambient room conditions for 1 to 2 hours, after which the specified measurements shall be performed. 1 cycle: a) -55+/- 3°C 30minutes b) +85+/- 2°C 30minutes Transit time shall be within 3 minutes. In accordance with EIA 364-32 method A condition I	Contact Resistance: 100mΩ Max.

6.3 Environmental Performance and Others.

Item	Test Condition	Requirement
Heat Resistance	Mate dummy card and exposed to 85 ±2°C for 96 hours. Upon completion of the exposure period. The specimens shall be conditions at ambient room conditions for 1 to 2 hours, after which the specified measurements shall be conditions at ambient room conditions for 1 to 2 hours, after which the specified measurement shall be performed. In accordance with EIA 364-17	Appearance: No damage Contact Resistance: 100mΩ Max.
Cold Resistance	Mate dummy card and exposed to -40 +2°C with 90~95% RH for 96 hours. Upon completion of the exposure period, the test specimens shall be conditions at ambient room conditions for 1 to 2 hours, after which the specified measurement shall be performed. In accordance with EIA 364-59	Appearance: No damage Contact Resistance: 100mΩ Max.

PRODUCT SPECIFICATION

Part Number	MEM2067	Rev	A	Date	11/09/14		
Product Description	Micro SD Memory Card Connector, SMT, Hinged, 1.80mm Profile.			Page	5		
Doc Number	MEM2067	Prepared	AO	Checked	ST	Approved	VJ

Item	Test Condition	Requirement
Humidity	40 +/-2°C in temperature with 90~95% RH for 96 hours, after testing connector shall be left alone for 1 to 2 hours in an ambient room. In accordance with EIA 364-31	Appearance: No damage Contact Resistance: 100mΩ Max. Insulation Resistance ≥ 1000MΩ Dielectric Strength: No breakdown
Salt Spray	Mate dummy card and exposed to the following salt mist conditions. Upon completion of the exposure period, salt deposits shall be removed by a gently wash or dip in running water, after which the specified measurements shall be performed. Salt Solution Concentration: 5% Spray Time: 48 hours Ambient Temperature: 35 +2°C In accordance with EIA-364-26.	No corrosion on contact area Contact Resistance: 100mΩ Max.
Solderability	Dip solder tails into the molten solder (held at 230 ±5°C) up to 0.5mm from the tip of tails for 30.5sec. in accordance with EA-364-52	Solder wetting: 95% of immersed area must show no voids, pinholes.
Resist to reflow heat	Mount connector, place in reflow oven and expose to the temperature profile shown in fig 1.0	No evidence of physical damage

PRODUCT SPECIFICATION

Part Number	MEM2067	Rev	A	Date	11/09/14		
Product Description	Micro SD Memory Card Connector, SMT, Hinged, 1.80mm Profile.				Page	6	
Doc Number	MEM2067	Prepared	AO	Checked	ST	Approved	VJ

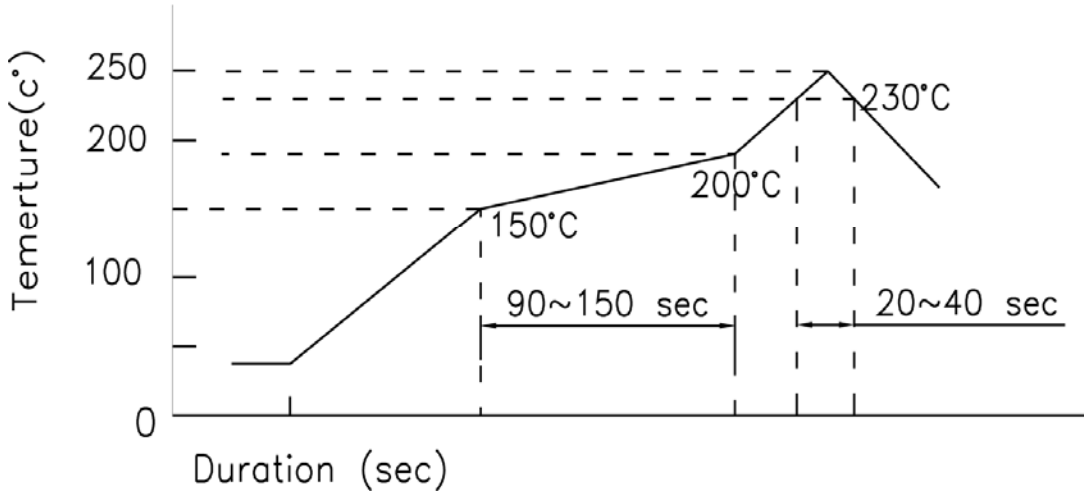

Fig. 1. Recommended Reflow Temp. Profile

7.0 PRODUCT QUALIFICATION AND TEST SEQUENCE

Test Group	Sample Groups									
Test Description	A	B	C	D	E	F	G	H	I	J
Examination of Products	1,5	1,4	1,5	1,3	1,7	1,4	1,5	1,3	1,3	
Contact Resistance	2,6	2,5	2,6		2,4, 6	2,5	2,4			
Insulation Resistance	3,7									
Dielectric Withstanding Voltage	4,8									
Durability		3								
Mechanical shock			3							
Temperature Rise				2						
Vibration			4							
Heat Resistance					3					
Cold Resistance					5					
Humidity	5									
Thermal Shock						3				
Salt Spray							3			
Solderability								2		
Resist to reflow heat									2	

PRODUCT SPECIFICATION

Part Number	MEM2067	Rev	A	Date	11/09/14		
Product Description	Micro SD Memory Card Connector, SMT, Hinged, 1.80mm Profile.			Page	7		
Doc Number	MEM2067	Prepared	AO	Checked	ST	Approved	VJ

Revision details :-

Revision	Information	Page	Release Date
A	Specification Released	-	11/09/14

X-ON Electronics

Largest Supplier of Electrical and Electronic Components

Click to view similar products for [Memory Card Connectors](#) category:

Click to view products by [GCT](#) manufacturer:

Other Similar products are found below :

[M21-033321-005](#) [6407-249V-25273P](#) [6407-249V-25343P](#) [6426-201-21343](#) [69.920.0553.0](#) [FCN-568P068-G/07-4V](#) [809180410000000](#)
[N7E50-7516PG-20-WF](#) [HMCAP001](#) [252-0144-000](#) [2041353-2](#) [33CFAE-DN](#) [502431-1011](#) [617230001](#) [NX1-32T-KT3K\(05\)](#) [95622-003LF](#)
[N7E50-U516RB-50-SIN0005](#) [95079-00CALF](#) [84648-056HLF](#) [33DVIR-29S12R](#) [125A-78C00](#) [MI20A-50PD-SF-EJL\(71\)](#) [KP10S-SF-](#)
[PEJ\(812\)](#) [504536-0691](#) [504580-0691](#) [CCM03-3109 B LFT](#) [MI21-50PD-SF\(91\)](#) [2309923-1](#) [61126-050CAHLF](#) [IC1GA-68PD-1.27DS-EJ\(72\)](#)
[GTFP08432B1HR](#) [G85DT17001P1EU](#) [G85B21611142HHR](#) [GSD090144HR](#) [G85D1140022P1HR](#) [GMCB05801124EU](#) [G85C11101152HHR](#)
[G85B231021B1HR](#) [G85D1160022HHR](#) [XKSIM-114](#) [123A-21M00](#) [123A-30B00](#) [123A-30A00](#) [123A-21A00](#) [123A-21B00](#) [123A-21E00](#)
[123A-30E00](#) [123A-30M00](#) [123A-40A00](#) [123A-40E00](#)