

# PRODUCT SPECIFICATION

<b>Part Number</b>	USB4085	<b>Rev</b>	A	<b>Date</b>	11/04/18		
<b>Product Description</b>	USB Type C Receptacle, Through-hole, PCB Top Mount			<b>Page</b>	1		
<b>Doc Number</b>	USB Type C	<b>Prepared</b>	CC	<b>Checked</b>	VJ	<b>Approved</b>	PH

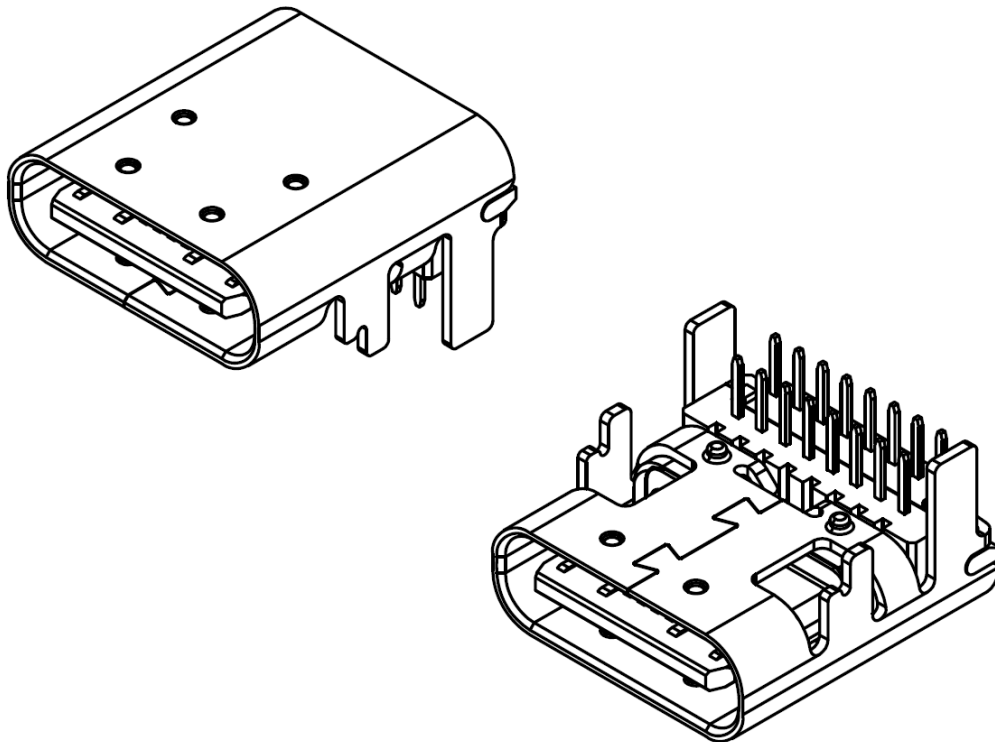

# PRODUCT SPECIFICATION

<b>Part Number</b>	USB4085	<b>Rev</b>	A	<b>Date</b>	11/04/18		
<b>Product Description</b>	USB Type C Receptacle, Through-hole, PCB Top Mount			<b>Page</b>	2		
<b>Doc Number</b>	USB Type C	<b>Prepared</b>	CC	<b>Checked</b>	VJ	<b>Approved</b>	PH

## 1.0 SCOPE.

This specification covers performance, tests and quality requirements for the USB Type C Receptacle range.USB4085.

## 2.0 PRODUCT NAME AND PART NUMBER.

USB Type C Receptacle range.USB4085.

## 3.0 PRODUCT SHAPE, DIMENSIONS AND MATERIAL.

Please refer to drawings.

## 4.0 RATINGS.

4.1 Current rating: 3.00A collectively for VBUS pins(i.e., pins A4, A9, B4, and B9)

4.25A collectively for GND pins(i.e., pins A1, A12, B1, and B12)

1.25A for VCONN (i.e., B5)

0.25A for all other pins, per pin

4.2 Voltage rating ..... 20V DC

4.3 Operating Temperature Range ..... -40°C to +85°C

## 5.0 TEST AND MEASUREMENT CONDITIONS.

Product is designed to meet electrical, mechanical and environmental performance requirements specified below. All tests are performed in ambient conditions unless otherwise specified.

## 6.0 PERFORMANCE.

Test No	Item	Test Condition	Requirement
6.0.1	Examination of Product	Visual, dimensional and functional inspection as per quality plan.	Product shall meet requirements of product drawing and specification.
	Reseating	Manually plug/unplug 3 times	No physical damage

# PRODUCT SPECIFICATION

<b>Part Number</b>	USB4085	<b>Rev</b>	A	<b>Date</b>	11/04/18		
<b>Product Description</b>	USB Type C Receptacle, Through-hole, PCB Top Mount			<b>Page</b>	3		
<b>Doc Number</b>	USB Type C	<b>Prepared</b>	CC	<b>Checked</b>	VJ	<b>Approved</b>	PH

## 6.1 Electrical Performance.

Test No	Item	Test Condition	Requirement
6.1.1	Low Level Contact Resistance	The low level contact resistance measurement is made from the solder tail of the receptacle to the soldering point of the plug. When measured at 20mV Max. open circuit at 100mA. Mated test contacts must be in a connector housing. In accordance with EIA-364-23, Test Condition B	40mΩ max (initial)
6.1.2	Insulation Resistance	Both unmated and Mated connectors, apply 100V DC for 1 minute at sea level between adjacent terminal or ground. In accordance with EIA-364-21.	100 MΩ Min (initial).
6.1.3	Dielectric Strength	Mate connectors, apply 100V AC (RMS) for 1 minute at sea level. In accordance with EIA-364-20.	No Breakdown.
6.1.4	Plug Side Latches Connection To Ground	Measure the resistance from each plug side latch to A1, A12, B1, and B12 individually. The test may be performed to the unmated plug or with a fixture that provides individual access points to pins and side latches without making electrical connection between any of the contacts or side latches being measured.	0.5 Ω maximum from each side latch to A1, A12, B1, and B12.
6.1.5	Contact current rating	A current of 3 A shall be applied collectively to VBUS pins (i.e., pins A4, A9, B4, and B9) and 1.25 A shall be applied to the VCONN pin (i.e., B5) as applicable, terminated through the corresponding GND pins (i.e., pins A1, A12, B1, and B12). A minimum current of 0.25 A shall also be applied individually to all the other contacts, as applicable.	The temperature rise shall not exceed 30°C at the outside surface of the shell.

# PRODUCT SPECIFICATION

<b>Part Number</b>	USB4085	<b>Rev</b>	A	<b>Date</b>	11/04/18		
<b>Product Description</b>	USB Type C Receptacle, Through-hole, PCB Top Mount			<b>Page</b>	4		
<b>Doc Number</b>	USB Type C	<b>Prepared</b>	CC	<b>Checked</b>	VJ	<b>Approved</b>	PH

## 6.2 Mechanical Performance.

Test No	Item	Test Condition	Requirement
6.2.1	Mating/Un-mating Force	Mate/Un-mated at a speed of 12.5mm/min. In accordance with EIA-364-13.	Mating force: within 5N to 20N (initial). Un-Mating force: within 8N to 20N up to 30cycles, within 6N to 20N after 10,000cycles
6.2.2	Durability	10,000 cycles at a cycle rate 500± 50per hour . In accordance with EIA-364-09.	Un-Mating force: within 6N to 20N Contact resistance: 50mΩ max Dielectric Strength: no breakdown
	Durability (Preconditioning)	50 cycles at a cycle rate 500± 50 per hour In accordance with EIA-364-09.	-
6.2.3	Vibration	EIA 364-28 Test Condition VII, Test Letter D 15 minutes in each of 3 mutually perpendicular directions. Both mating halves should be rigidly fixed so as not to contribute to the relative motion of one contact against another. The method of fixturing should be detailed in the test report	No evidence of physical damage and no discontinuity longer than 1 microsecond. Contact resistance: 50mΩ max.
6.2.4	4-Axis Continuity	Shall be tested for continuity under stress using a test fixture	No evidence of physical damage and no discontinuity longer than 1 microsecond.

# PRODUCT SPECIFICATION

<b>Part Number</b>	USB4085	<b>Rev</b>	A	<b>Date</b>	11/04/18		
<b>Product Description</b>	USB Type C Receptacle, Through-hole, PCB Top Mount			<b>Page</b>	5		
<b>Doc Number</b>	USB Type C	<b>Prepared</b>	CC	<b>Checked</b>	VJ	<b>Approved</b>	PH

## 6.3 Environmental Performance and Others.

Test No	Item	Test Condition	Requirement
6.3.1	Cyclic Temperature and Humidity Test	Cycle the connector between 25 °C ±3 °C at 80 % ±3% RH and 65 °C ±3 °C at 50 % ±3% RH. Ramp times should be 0.5 hour and dwell times should be 1.0 hour. Dwell times start when the temperature and humidity have stabilized within the specified levels. Perform 24 such cycles.	Contact Resistance: 50mΩ Max.
6.3.2	Salt Spray	Subject mated connectors to 5±1% salt-solution concentration, 35±2°C for 24 hours. In accordance with EIA-364-26, Test Condition B.	Shall meet visual requirements, No detrimental corrosion allowed in contact area and base metal exposed.
6.3.3	Thermal Shock	Temperature range from -55°C~+85°C .Start from -55°C. After 30 min. change to +85°C, change time is no more than 5min. Total 10 cycles. Test reference standard: EIA 364-32, test condition I	No physical damage. Contact Resistance (Low Level) 50m max.
6.3.4	Solderability	Solder pot temperature: 250±5°C for 3~5 seconds. In accordance with EIA-364-52.	95% of immersed area must show no voids, pin holes.
6.3.5	Temperature life	105° C without applied voltage for 120 hours. EIA-364-17, method A	Contact resistance : 50mΩ max
	Temperature Life (preconditioning)	105° C without applied voltage for 72 hours. EIA-364-17, method A	-
6.3.6	Mixed flowing gas	EIA 364-65, Class II A Samples should be placed in an environmentally controlled 'test chamber' that is monitored by a gas analyzing system for controlled concentrations of the specified gas mixture. Test coupons shall also be used and the weight gain reported. Test duration is 7 days.	Contact resistance : 50mΩ max
6.3.7	Thermal disturbance	Cycle the connector or socket between 15 °C ±3 °C and 85 °C ± 3 °C, as measured on the part. Ramps should be a minimum of 2 °C per minute, and dwell times should insure that the contacts reach the temperature extremes (a minimum of 5 minutes). Humidity is not controlled. Perform 10 such cycles.	Contact resistance : 50mΩ max

# PRODUCT SPECIFICATION

<b>Part Number</b>	USB4085	<b>Rev</b>	A	<b>Date</b>	11/04/18
<b>Product Description</b>	USB Type C Receptacle, Through-hole, PCB Top Mount			<b>Page</b>	6
<b>Doc Number</b>	USB Type C	<b>Prepared</b>	CC	<b>Checked</b>	VJ
		<b>Approved</b>			PH

## 7.0 RESISTANCE TO INFRARED REFLOW SOLDERING HEAT

Parameter	Reference	Specification
Average temperature gradient in preheating		2.5°C/s
Soak time	$T_{soak}$	2-3 minutes
Time above 217°C	$T_1$	60
Time above 230°C	$T_2$	50
Time above 250°C	$T_3$	5
Peak temperature in reflow	$T_{peak}$	255°C(-0/+5°C)
Temperature gradient in cooling		-5°C/s max

### Lead Free Process

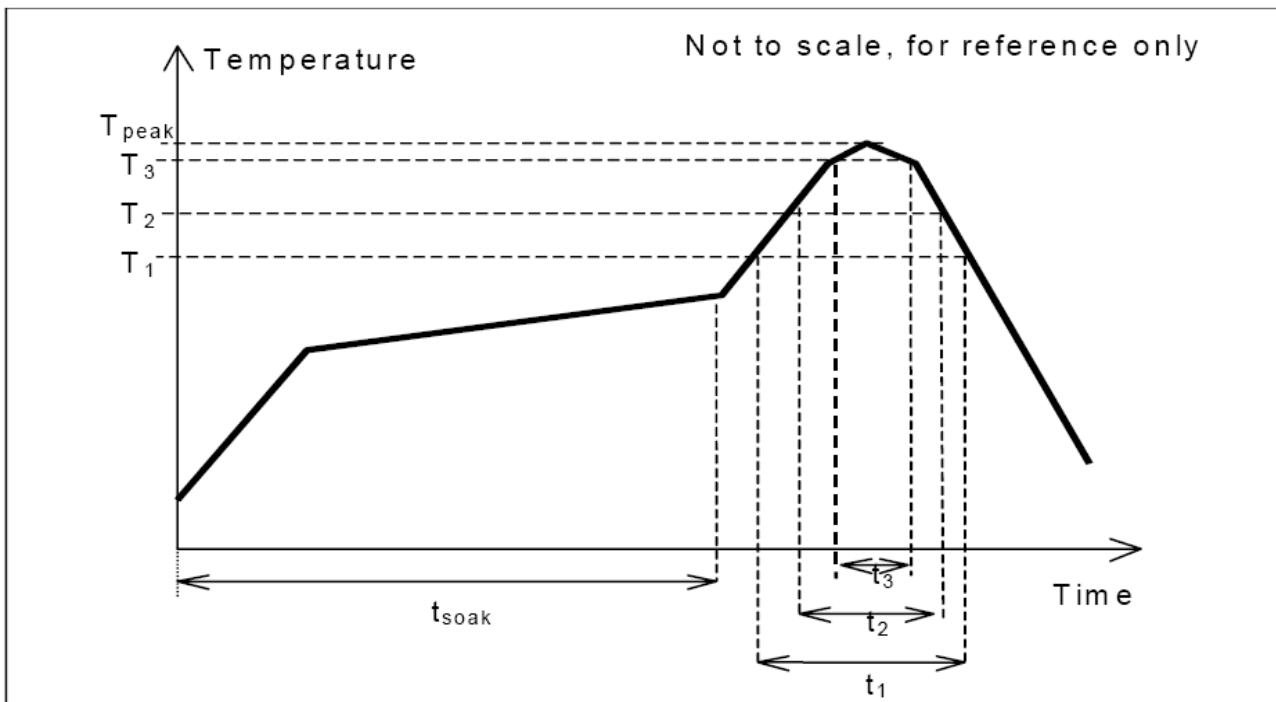

This profile is the minimum requirement for evaluating soldering heat resistance of components. Heat transfer method used for reflow soldering is hot air convection. The actual air temperatures used to achieve the specified profile is higher and largely dependent on the reflow equipment.

# PRODUCT SPECIFICATION

<b>Part Number</b>	USB4085	<b>Rev</b>	A	<b>Date</b>	11/04/18		
<b>Product Description</b>	USB Type C Receptacle, Through-hole, PCB Top Mount			<b>Page</b>	7		
<b>Doc Number</b>	USB Type C	<b>Prepared</b>	CC	<b>Checked</b>	VJ	<b>Approved</b>	PH

## 8.0 PRODUCT QUALIFICATION AND TEST SEQUENCE

Note: each group test needs 5pcs samples.

Test No	Description	Requirement
<b>Group A-1</b>		
6.0.1	Examination	Visual inspection; No physical damage
6.1.1	LLCR	40mΩ Max all contacts
6.2.2	Durability (preconditioning)	50 cycles; No physical damage
6.3.5	Temperature Life	
6.1.1	LLCR	50mΩ Max all contacts
6.0.1	Reseating	No physical damage
6.1.1	LLCR	50mΩ Max all contacts
6.0.1	Examination	Visual inspection; No physical damage
<b>Group A-2</b>		
6.0.1	Examination	Visual inspection; No physical damage
6.1.1	LLCR	40mΩ Max all contacts
6.2.2	Durability (preconditioning)	50 cycles; No physical damage
6.3.3	Thermal Shock	
6.1.1	LLCR	50mΩ Max all contacts
6.3.1	Humidity	
6.1.1	LLCR	50mΩ Max all contacts
6.0.1	Reseating	No physical damage
6.1.1	LLCR	50mΩ Max all contacts
6.0.1	Examination	Visual inspection; No physical damage
<b>Group A-3</b>		
6.0.1	Examination	Visual inspection; No physical damage
6.1.4	Plug Side Latches Connection To Ground	0.5 Ω maximum from each side latch to A1, A12, B1, and B12
6.1.1	LLCR	40mΩ Max all contacts

# PRODUCT SPECIFICATION

<b>Part Number</b>	USB4085	<b>Rev</b>	A	<b>Date</b>	11/04/18		
<b>Product Description</b>	USB Type C Receptacle, Through-hole, PCB Top Mount			<b>Page</b>	8		
<b>Doc Number</b>	USB Type C	<b>Prepared</b>	CC	<b>Checked</b>	VJ	<b>Approved</b>	PH

6.2.2	Durability (preconditioning)	50 cycles; No physical damage
6.3.5	Temperature Life (preconditioning)	
6.1.1	LLCR	50mΩ Max all contacts
6.2.3	Vibration	Discontinuity less than 1μs
6.1.1	LLCR	50mΩ Max all contacts
6.0.1	Examination	Visual inspection; No physical damage
<b>Group A-4</b>		
6.0.1	Examination	Visual inspection; No physical damage
6.1.1	LLCR	40mΩ Max all contacts
6.2.2	Durability (preconditioning)	50 cycles; No physical damage
6.3.5	Temperature Life (preconditioning)	
6.1.1	LLCR	50mΩ Max all contacts
6.3.6	Mixed Flowing Gases	
6.1.1	LLCR	50mΩ Max all contacts
6.3.7	Thermal Disturbance	
6.1.1	LLCR	50mΩ Max all contacts
6.0.1	Reseating	No physical damage
6.1.1	LLCR	50mΩ Max all contacts
6.0.1	Examination	Visual inspection; No physical damage
<b>Group A-7</b>		
6.0.1	Examination	Visual inspection; No physical damage
6.1.3	DWV	No breakdown or flashover
6.1.1	LLCR	40mΩ Max all contacts
6.2.2	Durability (preconditioning)	No physical damage
6.2.1	Insertion Force	Within the range of 5N to 20N.
6.2.1	Extraction force	Within the range of 8N to 20N. Initial Reading
6.2.2	Durability	25cycles, No physical damage



# PRODUCT SPECIFICATION

<b>Part Number</b>	USB4085	<b>Rev</b>	A	<b>Date</b>	11/04/18		
<b>Product Description</b>	USB Type C Receptacle, Through-hole, PCB Top Mount			<b>Page</b>	9		
<b>Doc Number</b>	USB Type C	<b>Prepared</b>	CC	<b>Checked</b>	VJ	<b>Approved</b>	PH

6.2.1	Extraction force	Within: a) 33% of initial reading & b) 8N to 20N
6.2.2	Durability	Perform 2468cycles and then rotate the plug or socket 180° and then perform 2500cycles. rotate the plug or socket 180° and then perform 2500cycles. rotate the plug or socket 180° and then perform 2500cycles. No physical damage
6.2.1	Extraction force	Within the range of 6N to 20N.
6.1.1	LLCR	50mΩ Max all contacts
6.1.3	DWV	No breakdown or flashover
6.1.2	Insulation Resistance	100 MΩ Max.
6.0.1	Examination	Visual inspection; No physical damage
<b>Group B-1</b>		
6.0.1	Examination	Visual inspection; No physical damage
6.2.4	4-Axis Continuity	Discontinuity less than 1μs
6.0.1	Examination	Visual inspection; No physical damage
<b>Group B-5</b>		

Test			Common Requirements
Title	EIA 364 Test	Severity or Condition of Test	
Critical Dimensions	18	According to USBIF requirement	All dimensions for component level qualification and overmold only for cable and adaptor assemblies.
EMC Shielding Spring Inspection	n/a	Visual inspection for compliance with Figure 1	No EMC shielding spring finger tip of the USB Full-Featured Type-C plug or USB 2.0 Type-C plug shall be exposed in the plug housing opening of the unmated Type_C plug.

# PRODUCT SPECIFICATION

<b>Part Number</b>	USB4085	<b>Rev</b>	A	<b>Date</b>	11/04/18
<b>Product Description</b>	USB Type C Receptacle, Through-hole, PCB Top Mount			<b>Page</b>	10
<b>Doc Number</b>	USB Type C	<b>Prepared</b>	CC	<b>Checked</b>	VJ
		<b>Approved</b>			PH

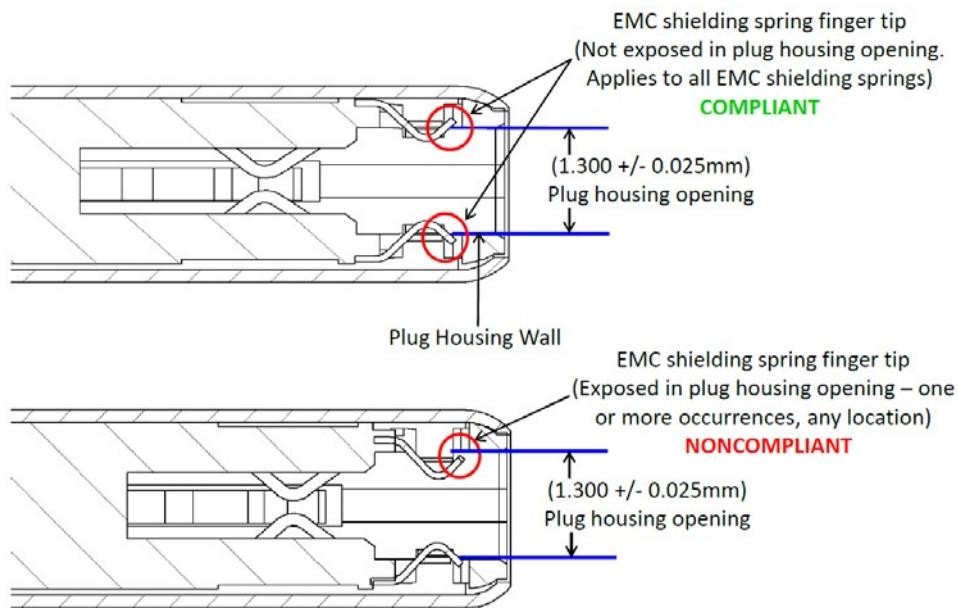

**Figure 1 EMC Shielding Spring Tip Requirements**

<b>Group B-6</b>		
6.0.1	Examination	Visual inspection; No physical damage
6.1.5	Contact Current Rating	The Temperature Rise shall not exceed 30°C
6.0.1	Examination	Visual inspection; No physical damage

# PRODUCT SPECIFICATION

<b>Part Number</b>	USB4085	<b>Rev</b>	A	<b>Date</b>	11/04/18		
<b>Product Description</b>	USB Type C Receptacle, Through-hole, PCB Top Mount			<b>Page</b>	11		
<b>Doc Number</b>	USB Type C	<b>Prepared</b>	CC	<b>Checked</b>	VJ	<b>Approved</b>	PH

## Revision details :-

Revision	Information	Page	Release Date
A	Specification released.	-	11/04/18

## X-ON Electronics

Largest Supplier of Electrical and Electronic Components

*Click to view similar products for [USB Connectors](#) category:*

*Click to view products by [GCT](#) manufacturer:*

Other Similar products are found below :

[65-647-8-BK-BU](#) [950](#) [952](#) [E8144-B01021-L](#) [A-USB B-TOP-C](#) [MUSBA511N5](#) [MUSBD11135](#) [217450-1](#) [KMBVX-TH-5S-B30](#) [896-30-004-00-000000](#) [KUSBVX-BS1N-W30](#) [KUSBX-AP-KIT-SCBLK](#) [KUSBX-AS2N-W](#) [KUSBX-SMT2AP1S-W](#) [KUSBX-SMT2AP1S-W30](#) [935](#) [957](#) [30-498-6](#) [SK-60A-2](#) [17-210051](#) [1734082-1](#) [30-1574](#) [30-470](#) [30-489](#) [30-541](#) [30-572-3](#) [A-USB A-2P-C](#) [MIKROE-1451](#) [USBFTV2PEM2G](#) [USBFTVC6ZN](#) [KUSBX-AS2N-W30](#) [KUSBX-SLAS1N-W](#) [KUSBX-SMT-AS1N-W30](#) [4689-1](#) [1-1734084-2](#) [E8110-001-01](#) [33UBARS1-04SW11](#) [33UBAR-04SW11](#) [USBF21ZNSCC](#) [USBBFTV6ZC](#) [10135326-001LF](#) [M9177/3-1](#) [USB-A-S-F-B-VT](#) [925](#) [4198](#) [690-024-633-031](#) [KUSBEX-BSFS1N-W](#) [USBFTVC6MRG](#) [UA-20BMFA-SL8001](#) [17-250101](#)