

GE Industrial Solutions is a first class global supplier of low and medium voltage products including wiring devices, residential and industrial electrical distribution components, automation products, enclosures and switchboards. Demand for the company's products comes from wholesalers, installers, panelboard builders, contractors, OEMs and utilities worldwide.

[www.ge.com/ex/industrialsolutions](http://www.ge.com/ex/industrialsolutions)  
[www.ge.com/uk/industrialsolutions](http://www.ge.com/uk/industrialsolutions)

**Belgium**

GE Industrial Belgium  
Nieuwevaart 51  
B-9000 Gent  
Tel. +32 (0)9 265 21 11

**Finland**

GE Industrial Solutions  
Kuortaneenkatu 2  
FI-00510 Helsinki  
Tel. +358 (0)10 394 3760

**France**

GE Industrial Solutions  
Paris Nord 2  
13, rue de la Perdrix  
F-95958 Roissy CDG Cédex  
Tel. +33 (0)800 912 816

**Germany**

GE Industrial Solutions  
Robert-Bosch Str. 2a  
D-50354 Hürth-Efferen  
Tel. +49 (0) 2233/ 9719-0

**Hungary**

GE Hungary Kft.  
Váci ut 81-83.  
H-1139 Budapest  
Tel. +36 1 447 6050

**Italy**

GE Industrial Solutions  
Centro Direzionale Colleoni  
Via Paracelso 16  
Palazzo Andromeda B1  
I-20864 Agrate Brianza (MB)  
Tel. +39 039 637 3701

**Netherlands**

GE Industrial Solutions  
Parallelweg 10  
NL-7482 CA Haaksbergen  
Tel. +31 (0)53 573 03 03

**Poland**

GE Power Controls  
Ul. Odrowaza 15  
03-310 Warszawa  
Tel. +48 22 519 76 00

**Portugal**

GE Industrial Solutions  
Rua Camilo Castelo Branco, 805  
Apartado 2770  
P-4401-601 Vila Nova de Gaia  
Tel. +351 22 374 60 00

**Russia**

GE Industrial Solutions  
27/8, Electrozavodskaya street  
Moscow, 107023  
Tel. +7 495 937 11 11

**South Africa**

GE Industrial Solutions  
130 Gazelle Avenue  
Corporate Park Midrand 1685  
P.O. Box 76672 Wendywood 2144  
Tel. +27 11 238 3000

**Spain**

GE Industrial Solutions  
P.I. Clot del Tufau, s/n  
E-08295 Sant Vicenç de Castellet  
Tel. +34 900 993 625

**United Arab Emirates**

GE Industrial Solutions  
Injaz Building, 3rd Floor  
Dubai Internet City  
PO Box 11549, Dubai  
Tel. +971 4 4546912

**United Kingdom**

GE Industrial Solutions  
Houghton Centre  
Salhouse Road  
Blackmills  
Northampton  
NN4 7EX  
Tel. +44 (0)800 587 1239

**Asia and Far East**

GE Industrial Solutions  
4F, Building 2, CTP, No1 Hua Tuo Rd.  
Zhang Jiang Hi-Tech Park  
Shanghai, China 201203  
Tel. +86 21 3877 7888

**Latin America**

GE Industrial Solutions  
790 N.W. 107th Avenue, Suite 200  
Miami, FL 33172 USA  
Tel. +1 305 551 5155

**North America**

GE Industrial Solutions  
41 Woodford Avenue  
Plainville CT, USA 06062  
and  
12305 Kurland Drive  
Houston, TX USA 77034  
Tel. +1 800-431-7867

# Controls and Power Electronics

ED.04

## For industrial applications





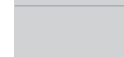
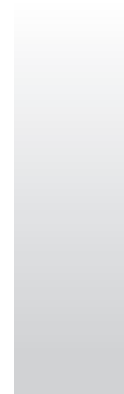

Intro

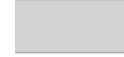

**POWER DEVICES**

Contactors and overload relays

A

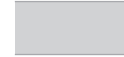

Auxiliary relays and contactors

B

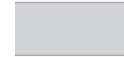

Motor protection devices

C



Applications

D

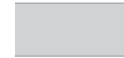

Main switches

E



**AUXILIARY DEVICES**

Control and signalling units

F

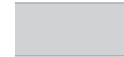

Electronic relays and limit switches

G

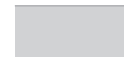

**POWER ELECTRONICS**

Speed drive units

H

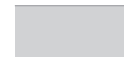

Soft starters

I

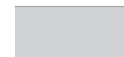

Lighting dimmer-stabilizer/Numerical index

J/X

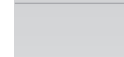
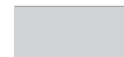

## A

### Contactors and thermal overload relays

#### Efficor - Global contactors



Compact starter either with thermal overload relay or manual motor starter.

● A.2

#### Series EA - Minicontactors



Three pole minicontactors  
7A (AC3)  
16A (AC1)

● A.42

#### Series M - Contactors



3 and 4P (4NO, 2NO+2NC, 4NC)  
6, 9 and 12A (AC-3)  
20A (AC-1) Control circuit AC and DC

● A.44

#### Series CL - Contactors



3 and 4P (4NO, 2NO+2NC) 9 to 105A (AC-3) 25 to 140A (AC-1) AC, DC and with electronic module

● A.52

#### Series CK - Contactors



3 and 4P (4NO) 150 to 825A (AC-3) 200 to 1250A (AC-1) AC, DC and with electronic module

● A.62

#### Series MTO - Thermal overload relays



For minicontactors series M from 0.11 to 14A

● A.68

#### Series RT - Thermal overload relays



For contactors series CL and CK from 0.16 to 850A  
Class 10A, 10, 20, 30

● A.70

#### Series RE - Electronic overload relays



For contactors series CL from 0.1 to 150A

● A.74

#### EntelliPro



Intelligent motor management relay

● A.76

#### Series CSCN - Contactors for capacitors switching

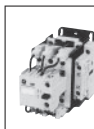

● A.144

#### Series 390.R - Clapper contactors



40A to 800A (AC-3)  
45A to 1200A (AC-1)

● A.150

## B

### Plug-in relays and auxiliary contactors

#### Series PRC - Plug-in relays



Miniature plug-in relays  
Standard 8-11 pin plug-in relays  
Interface relay

● B.2

#### Series M - Auxiliary contactors

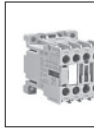

I<sub>th</sub> = 16A

● B.8

#### Series RL - Auxiliary contactors



I<sub>th</sub> = 20A

● B.14

## C

### Motor protection devices

#### Surion - Manual motor starter



Thermal and magnetic protection -  
Magnetic protection only  
Setting ranges from 0.1 to 63A

● C.2

#### Series SFK - Motor protection circuit breaker



Thermal and magnetic protection of AC and DC motors  
Setting ranges from 0.1 to 25A

● C.32

## D

### Applications

#### Technical data

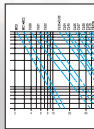

Utilization categories  
Electrical endurance  
Machine directive -  
B10d value for contactors

● D.3-D.8

#### Selection tables / Dimensional drawings / Wiring diagrams

● D.9-D.48

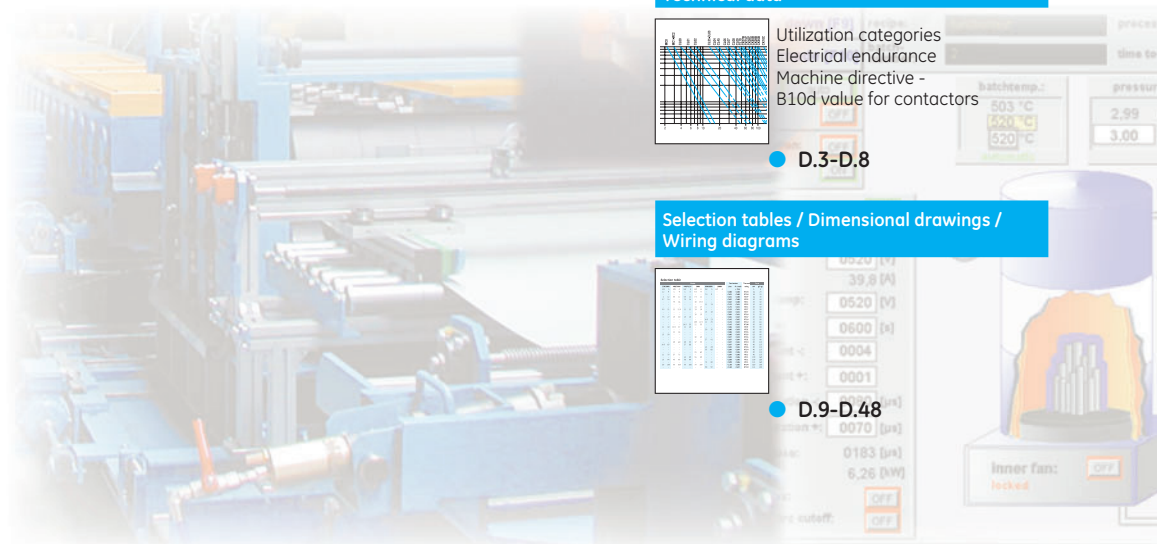

## E

### Main switches

#### Series ML



**Standard programme**  
Main switches and emergency-stop switches for machinery  
**enclosed switches**

● E.4

#### Switches for photovoltaic applications



To isolate the solar panels from the inverter, from 16 to 100Adc

● E.13

## F

### Control and signalling units

#### Series P9 - Panel mounting - Units Ø 22 mm



● F.8

#### Series P9 - Base mounting



● F.23

#### Series P9 - Push-button stations / Equipped boxes



● F.24-F.25

#### Series P9 - Common accessories



● F.30

#### Series 077 - Units Ø 30 mm



● F.42

#### Series 105 - Signalling devices



● F.57

## G

### Electronic relays and limit switches

#### Series NMV - Multivoltage relays



**22.5mm module**  
Direct supply voltage (24-240V AC/DC)  
With transformer

● G.2

#### Series D - Single voltage electronic timers



**45mm module**  
Direct supply voltage

● G.3

#### Limit switches

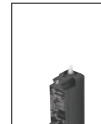

**Series IS and IM**  
Metal and thermoplastic limit switches  
**Series IUG**  
Thermoplastic limit switches  
**Series IZ**  
Miniature thermoplastic limit switches  
**Series 114FCT**  
Three pole limit switches

● G.22

#### Pressure switches

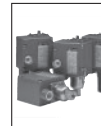

**Series 115**

● G.36

## H

### Speed drive units

#### VAT20



Single-phase or three-phase digital inverters for controlling the speed of three-phase induction AC motors from 0.2 to 2.2 kW IP20 or IP65

● H.2

#### VAT200



From 0.4 to 2.2kW at 200V, single phase power supply  
From 0.4 to 7.5kW at 200V, three phase power supply  
From 0.75 to 11kW at 400V, three phase power supply

● H.8

#### AF6 drives



Drives designed for general purpose applications

● H.18

## I

### Softstarters

#### ASTAT S - Soft starter



Small soft starter with integral by-pass

● I.3

#### ASTAT XT - Digital soft starter



Digital soft starter for 3 phase standard induction motors

● I.8

Extended index

Intro

A

B

C

D

E

F

G

H

I

J/X

Visit [www.ge.com/ex/industrialsolutions](http://www.ge.com/ex/industrialsolutions) and click on 

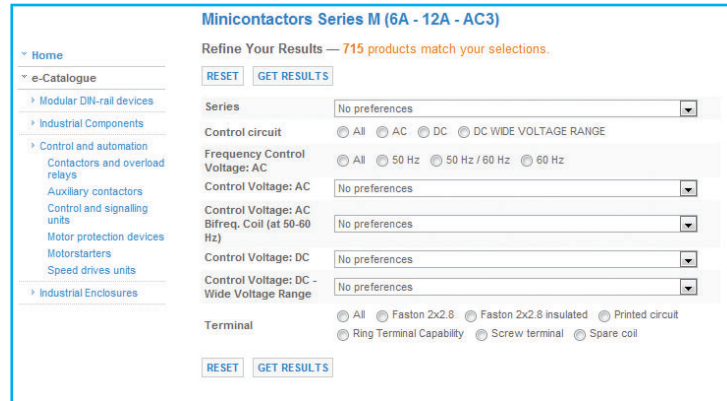

- All product info available in one central place
- All product info is available to download, print or e-mail
- Always the latest up-to-date info

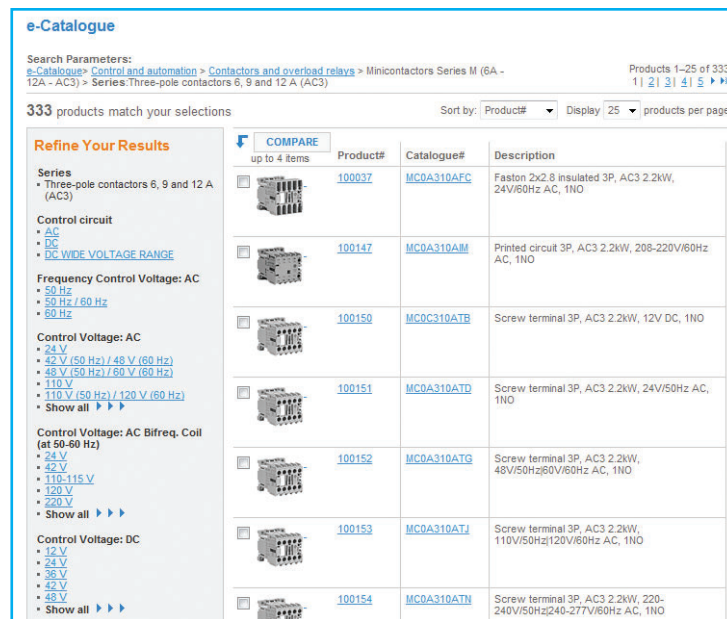

- Use the **Quick-search** using a **part number** or **keyword**
- Find a product by using the **parametric search**, simply enter the technical characteristics you are looking for
- **Compare** up to 4 products and view the technical data and accessories on a single page
- **High resolution images** are available by clicking on the small product image
- Product pages contain all available data: **technical specifications, dimensional and CAD drawings, product descriptions, ...**
- The data also displays the **available functions and accessories** for each product

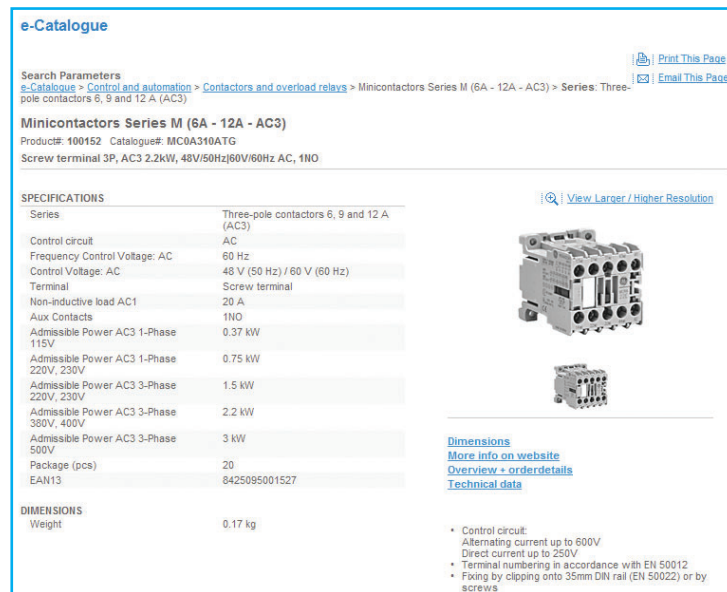

SPECIFICATIONS	
Series	Three-pole contactors 6, 9 and 12 A (AC3)
Control circuit	AC
Frequency Control Voltage: AC	60 Hz
Control Voltage: AC	48 V (50 Hz) / 60 V (60 Hz)
Terminal	Screw terminal
Non-inductive load AC1	20 A
Aux Contacts	1NO
Admissible Power AC3 1-Phase 115V	0.37 kW
Admissible Power AC3 1-Phase 220V, 230V	0.75 kW
Admissible Power AC3 3-Phase 220V, 230V	1.5 kW
Admissible Power AC3 3-Phase 380V, 400V	2.2 kW
Admissible Power AC3 3-Phase 500V	3 kW
Package (pcs)	20
EAN13	6425095001527

### High resolution images available

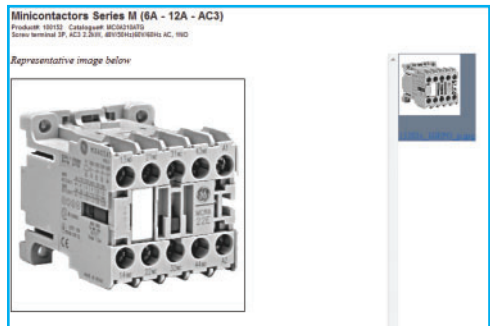

- Control circuit: Alternating current up to 600V, Direct current up to 250V
- Terminal numbering in accordance with EN 50012
- Fixing by clipping onto 35mm DIN rail (EN 50022) or by screws



## Order codes

- A.2 New **Efficor** global contactors
- A.42 **Series EA** - Three pole minicontactors
- A.44 **Series M** - Three and four pole contactors
- A.52 **Series CL** - Three and four pole contactors
- A.62 **Series CK** - Three and four pole contactors
- A.68 **Series MTO** - Thermal overload relays
- A.70 **Series RT** - Thermal overload relays
- A.74 **Series RE** - Electronic overload relay
- A.76 **EntelliPro** - Intelligent motor management relay
- A.144 **Series CSCN** - Contactors for capacitors switching
- A.150 **Series 390.R** - Clapper contactors

## POWER DEVICES

## Contactors and overload relays

Intro

A

## Technical data

- A.83 Series M Auxiliary relays and contactors
- A.91 Series CL
- A.102 Series CK Motor protection devices
- A.120 Series MTO
- A.122 Series RT Applications
- A.128 Series RE Main switches

B

C

D

E

## Dimensional drawings

- A.110 Series M
- A.112 Series CL AUXILIARY DEVICES Control and signalling units

F

- A.118 Series CK
- A.121 Series MTO Electronic relays and limit switches

G

- A.126 Series RT
- A.130 Series RE POWER ELECTRONICS Speed drive units

H

## Wiring diagrams

- A.131 Series M Soft starters
- A.132 Series CL
- A.133 Series CK Lighting dimmer-stabilizer/Numerical index

I

J/X



## Most reliable technology

- Standard materials for food & beverage and transportation purposes ... complying the latest rail standards
- Highest reliable product performance for worldwide applications
- Energy efficient design ... ecological mindset

### Best electrical endurance

Electrical endurance > 1.7 million operations  
AC3 category at rated current

Reliability data per standard EN ISO 13849-1

EC09-12 2x10<sup>6</sup>ops  
EC18-25 1.7x10<sup>6</sup>ops  
EC32-40 1.37x10<sup>6</sup>ops

### Widest temperature operation

from -40°C to +55°C  
Suitable for extreme temperatures

### Reduced flammability risk and lower toxicity

For demanding applications as lifts, appliances and transportation

### Lowest noise production: 32dBA

Perfect answer to demanding applications like hospitals

### Compliant with International standards for plastic parts

NF 16-101 & NF 16-102  
DIN 5510.2  
Safe ecological plastic for all applications

### Only one frame covering 9 up to 40A series

#### Three different depths

- Depth 1: 9A up to 18A
- Depth 2: 25A
- Depth 3: 32A up to 40A



## High installation benefits

- Smart, various wiring and connectivity technologies ... fast assembly of starter solutions
- Smaller product dimensions for panel design and motor control centers ... integrated auxiliary contacts in standard product
- Modular and compact motor starter solutions

## Best in class

- Highest B10d data as per ISO.13849-1
- Optimized power per size
- Lower number of stock keeping units ... reducing stock complexity for distributors, panelbuilders and OEM customers
- Outstanding range of power contactors and motor starter solutions ... including wide range of accessories

## Standards

IEC/EN 60947-1  
IEC/EN 60947-4-1  
IEC/EN 60947-5-1  
EN 50005  
UL 508  
CSA 22.2/14  
VDE 0660/102

## Approvals

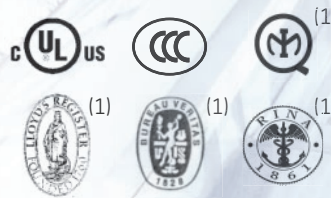

(1) In progress



A new dimension



## Compact starter

Significant space reduction in the cabinet: Compact starter either with thermal overload relay or manual motor starter.

Starter mounting plates for friendly maintenance (easy removal of MMS Surion and/or contactor).  
 Busbar systems and wiring kits allow safe cabling avoiding mistakes, guaranteeing finger safe protection up to 6kV.

### Contactor with manual motor starter

Link module for compact starter  
 Full coil access at the bottom

### Contactor with thermal overload relay

Uniformity in compact design  
 Thermal overload relay mounted direct to the contactor.  
 All connections available



Even efficient



in global contactors

efficor™

Benefits

Intro

A

B

C

D

E

F

G

H

I

J/X



New

# Secure connection

## Smart connectivity

- Design of intelligent base plate

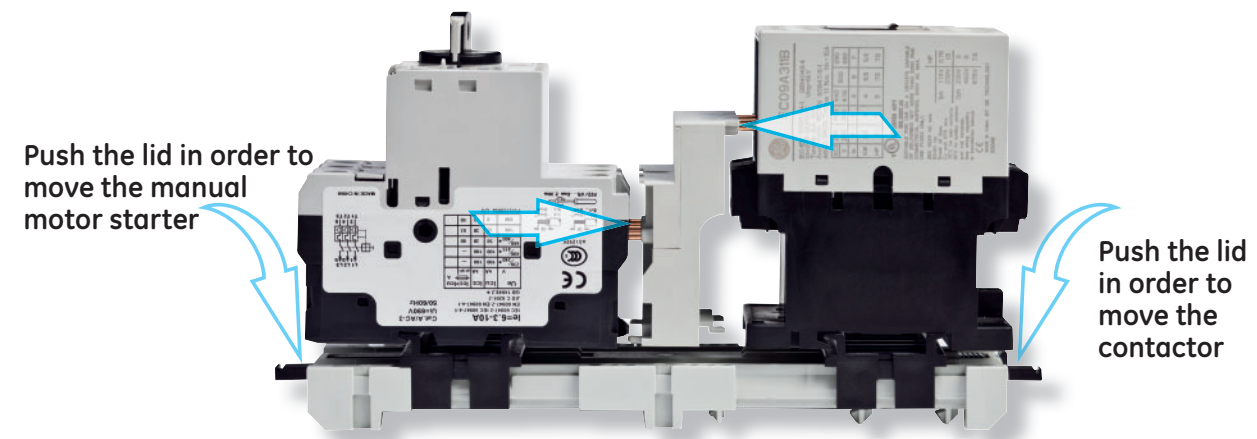
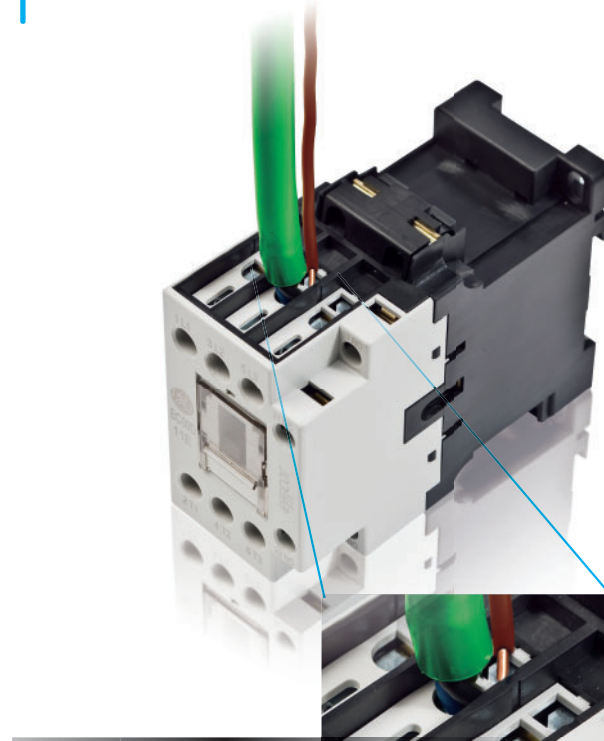
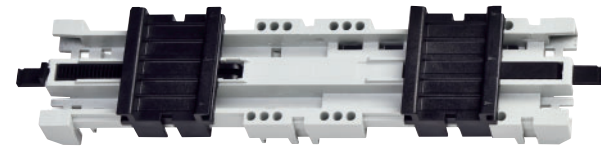

Global contactors

Intro

A

B

C

D

E

F

G

H

I

J/X

# Time saving

# Main advantages

## Double box terminals

**Identical torque (2.2 Nm) for 9A up to 40A contactors.**  
No need for different screwdrivers.

- Double box clamps for the whole range
- Cables from 0.75mm<sup>2</sup> up to 16mm<sup>2</sup> in the same box clamps terminal for 4kW up to 18.5kW.
- No risk for loosing cables
- Avoid temperature rising on the small cable

## No tools needed

Mounting or dismounting the contactors on/from the DIN-rail can be done without tools.  
Even for the mounting of accessories and auxiliaries to the contactor no tools are required.

## Quick assembly of direct online starter

- User friendly design of link modules and base plates to combine manual motor starter and contactor.
- Smart busbar systems and wiring kits.

## Easy identification

Self explanatory description of the catalogue number is an important advantage

**Example: EC 09 A 3 11 B 230**

- EC:** Means Efficor Contactor range
- 09:** 9A in AC3 application
- A:** Type of control voltage
  - A stands for AC
  - D stands for DC
- 3:** Number of main poles
  - 3 stands for 3 poles
  - 4 stands for 4 poles
- 11:** Number of auxiliary contacts built-in 1NO and 1NC
- B:** Type of terminal
  - B stands for Box terminal
  - R stands for Ring terminal
- 230:** Coil voltage
- W:** End character for DC contactors
  - W stands for Wide voltage and built-in diode
  - L stands for Low consumption

- Time saving
- Space saving
- Stock saving
- Secure connection
- Energy efficiency design
- Reliable technology
- Smart connecting



Benefits

Intro

A

B

C

D

E

F

G

H

I

J/X



New

3 pole contactors - Double box terminals

Max. operating current		Admissible power AC3				Electrical endurance	Aux. cont.	Control circuit														
Not inductive load AC1 A	Motors <440V 3Ph 50/60Hz AC3 A	220-230V	380-400V	440V	500V	Cat. AC3 Operations	NO NC	AC			DC			Pack								
		kW HP	kW HP	kW HP	kW HP			Voltage	Cat. no.	Ref. no.	Voltage	Cat. no. <sup>(1)</sup>	Ref. no.									
25	9	2.2 3	4 5.5	4 5.5	5.5 7.5	1.7x10 <sup>6</sup>		1 1 12	EC09A311B012	267001	12	EC09D311B012W	267085	5								
								1 1 24	EC09A311B024	267002	24	EC09D311B024W	267086	5								
								1 1 42	EC09A311B042	267003	36	EC09D311B036W	267087	5								
								1 1 48	EC09A311B048	267004	48	EC09D311B048W	267088	5								
								1 1 110	EC09A311B110	267005	60	EC09D311B060W	267089	5								
								1 1 120	EC09A311B120	267006	72	EC09D311B072W	267090	5								
								1 1 208	EC09A311B208	267007	110	EC09D311B110W	267091	5								
								1 1 230	EC09A311B230	267008	125	EC09D311B125W	267092	5								
								1 1 240	EC09A311B240	267009	230	EC09D311B230W	267093	5								
								1 1 400	EC09A311B400	267010	250	EC09D311B250W	267094	5								
								1 1 440	EC09A311B440	267011	440	EC09D311B440W	267095	5								
								1 1 480	EC09A311B480	267012	24	EC09D311B024L	267096	5								
								1 1 500	EC09A311B500	267013	48	EC09D311B048L	267097	5								
								1 1 575	EC09A311B575	269075	110	EC09D311B110L	267098	5								
								1 1 600	EC09A311B600	267014	230	EC09D311B230L	267099	5								
								25	12	3 4	5.5 7.5	5.5 7.5	7.5 10	1.7x10 <sup>6</sup>		1 1 12	EC12A311B012	267015	12	EC12D311B012W	267100	5
																1 1 24	EC12A311B024	267016	24	EC12D311B024W	267101	5
1 1 42	EC12A311B042	267017	36	EC12D311B036W	267102	5																
1 1 48	EC12A311B048	267018	48	EC12D311B048W	267103	5																
1 1 110	EC12A311B110	267019	60	EC12D311B060W	267104	5																
1 1 120	EC12A311B120	267020	72	EC12D311B072W	267105	5																
1 1 208	EC12A311B208	267021	110	EC12D311B110W	267106	5																
1 1 230	EC12A311B230	267022	125	EC12D311B125W	267107	5																
1 1 240	EC12A311B240	267023	230	EC12D311B230W	267108	5																
1 1 400	EC12A311B400	267024	250	EC12D311B250W	267109	5																
1 1 440	EC12A311B440	267025	440	EC12D311B440W	267110	5																
1 1 480	EC12A311B480	267026	24	EC12D311B024L	267111	5																
1 1 500	EC12A311B500	267027	48	EC12D311B048L	267112	5																
1 1 575	EC12A311B575	269076	110	EC12D311B110L	267113	5																
1 1 600	EC12A311B600	267028	230	EC12D311B230L	267114	5																
32	18	4 5.5	7.5 10	7.5 10	10 13.5	1.7x10 <sup>6</sup>										1 1 12	EC18A311B012	267029	12	EC18D311B012W	267115	5
																1 1 24	EC18A311B024	267030	24	EC18D311B024W	267116	5
								1 1 42	EC18A311B042	267031	36	EC18D311B036W	267117	5								
								1 1 48	EC18A311B048	267032	48	EC18D311B048W	267118	5								
								1 1 110	EC18A311B110	267033	60	EC18D311B060W	267119	5								
								1 1 120	EC18A311B120	267034	72	EC18D311B072W	267120	5								
								1 1 208	EC18A311B208	267035	110	EC18D311B110W	267121	5								
								1 1 230	EC18A311B230	267036	125	EC18D311B125W	267122	5								
								1 1 240	EC18A311B240	267037	230	EC18D311B230W	267123	5								
								1 1 400	EC18A311B400	267038	250	EC18D311B250W	267124	5								
								1 1 440	EC18A311B440	267039	440	EC18D311B440W	267125	5								
								1 1 480	EC18A311B480	267040	24	EC18D311B024L	267126	5								
								1 1 500	EC18A311B500	267041	48	EC18D311B048L	267127	5								
								1 1 575	EC18A311B575	269077	110	EC18D311B110L	267128	5								
								1 1 600	EC18A311B600	267042	230	EC18D311B230L	267129	5								
								45	25	7.5 10	11 15	12 16	15 20	1.5x10 <sup>6</sup>		1 1 12	EC25A311B012	267043	12	EC25D311B012W	267130	1
																1 1 24	EC25A311B024	267044	24	EC25D311B024W	267131	1
1 1 42	EC25A311B042	267045	36	EC25D311B036W	267132	1																
1 1 48	EC25A311B048	267046	48	EC25D311B048W	267133	1																
1 1 110	EC25A311B110	267047	60	EC25D311B060W	267134	1																
1 1 120	EC25A311B120	267048	72	EC25D311B072W	267135	1																
1 1 208	EC25A311B208	267049	110	EC25D311B110W	267136	1																
1 1 230	EC25A311B230	267050	125	EC25D311B125W	267137	1																
1 1 240	EC25A311B240	267051	230	EC25D311B230W	267138	1																
1 1 400	EC25A311B400	267052	250	EC25D311B250W	267139	1																
1 1 440	EC25A311B440	267053	440	EC25D311B440W	267140	1																
1 1 480	EC25A311B480	267054	24	EC25D311B024L	267141	1																
1 1 500	EC25A311B500	267055	48	EC25D311B048L	267142	1																
1 1 575	EC25A311B575	269078	110	EC25D311B110L	267143	1																
1 1 600	EC25A311B600	267056	230	EC25D311B230L	267144	1																
60	32	9 12	15 22	15 22	18 25	1.5x10 <sup>6</sup>										0 0 12	EC32A300B012	267057	12	EC32D300B012W	267145	1
																0 0 24	EC32A300B024	267058	24	EC32D300B024W	267146	1
								0 0 42	EC32A300B042	267059	36	EC32D300B036W	267147	1								
								0 0 48	EC32A300B048	267060	48	EC32D300B048W	267148	1								
								0 0 110	EC32A300B110	267061	60	EC32D300B060W	267149	1								
								0 0 120	EC32A300B120	267062	72	EC32D300B072W	267150	1								
								0 0 208	EC32A300B208	267063	110	EC32D300B110W	267151	1								
								0 0 230	EC32A300B230	267064	125	EC32D300B125W	267152	1								
								0 0 240	EC32A300B240	267065	230	EC32D300B230W	267153	1								
								0 0 400	EC32A300B400	267066	250	EC32D300B250W	267154	1								
								0 0 440	EC32A300B440	267067	440	EC32D300B440W	267155	1								
								0 0 480	EC32A300B480	267068	24	EC32D300B024L	267156	1								
								0 0 500	EC32A300B500	267069	48	EC32D300B048L	267157	1								
								0 0 575	EC32A300B575	269079	110	EC32D300B110L	267158	1								
								0 0 600	EC32A300B600	267070	230	EC32D300B230L	267159	1								
								60	40	11 15	18.5 25	22 30	25 34	1.5x10 <sup>6</sup>		0 0 12	EC40A300B012	267071	12	EC40D300B012W	267160	1
																0 0 24	EC40A300B024	267072	24	EC40D300B024W	267161	1
0 0 42	EC40A300B042	267073	36	EC40D300B036W	267162	1																
0 0 48	EC40A300B048	267074	48	EC40D300B048W	267163	1																
0 0 110	EC40A300B110	267075	60	EC40D300B060W	267164	1																
0 0 120	EC40A300B120	267076	72	EC40D300B072W	267165	1																
0 0 208	EC40A300B208	267077	110	EC40D300B110W	267166	1																
0 0 230	EC40A300B230	267078	125	EC40D300B125W	267167	1																
0 0 240	EC40A300B240	267079	230	EC40D300B230W	267168	1																
0 0 400	EC40A300B400	267080	250	EC40D300B250W	267169	1																
0 0 440	EC40A300B440	267081	440	EC40D300B440W	267170	1																
0 0 480	EC40A300B480	267082	24	EC40D300B024L	267171	1																
0 0 500	EC40A300B500	267083	48	EC40D300B048L	267172	1																
0 0 575	EC40A300B575	269080	110	EC40D300B110L	267173	1																
0 0 600	EC40A300B600	267084	230	EC40D300B230L	267174	1																

(1) End character: W = Wide voltage and built-in diode  
L = Low consumption

Global contactors

Intro

A

B

C

D

E

F

G

H

I

J/X



New

4 pole contactors - Double box terminals

Max. operating current		Admissible power AC1				Electrical endurance	Power cont.	Control circuit						
Not inductive load AC1 A	Motors <440V 3Ph 50/60Hz AC3 A	220-230V kW	380-400V kW	440V kW	500V kW	Cat. AC1 Operations	NO NC	AC			DC			Pack
								Voltage	Cat. no.	Ref. no.	Voltage	Cat. no. <sup>(1)</sup>	Ref. no.	
25	12	9.5	16.5	18	21.5	4x10 <sup>5</sup>	4 0	12	EC12A400B012	267175	12	EC12D400B012W	267231	5
								24	EC12A400B024	267176	24	EC12D400B024W	267232	5
								42	EC12A400B042	267177	36	EC12D400B036W	267233	5
								48	EC12A400B048	267178	48	EC12D400B048W	267234	5
								110	EC12A400B110	267179	60	EC12D400B060W	267235	5
								120	EC12A400B120	267180	72	EC12D400B072W	267236	5
								208	EC12A400B208	267181	110	EC12D400B110W	267237	5
								230	EC12A400B230	267182	125	EC12D400B125W	267238	5
								240	EC12A400B240	267183	230	EC12D400B230W	267239	5
								400	EC12A400B400	267184	250	EC12D400B250W	267240	5
								440	EC12A400B440	267185	440	EC12D400B440W	267241	5
								480	EC12A400B480	267186				
								500	EC12A400B500	267187	24	EC12D400B024L	267242	5
								575	EC12A400B575	269081	48	EC12D400B048L	267243	5
								600	EC12A400B600	267188	110	EC12D400B110L	267244	5
											230	EC12D400B230L	267245	5
32	18	12	22	23	27.5	6x10 <sup>5</sup>	4 0	12	EC18A400B012	267189	12	EC18D400B012W	267246	5
								24	EC18A400B024	267190	24	EC18D400B024W	267247	5
								42	EC18A400B042	267191	36	EC18D400B036W	267248	5
								48	EC18A400B048	267192	48	EC18D400B048W	267249	5
								110	EC18A400B110	267193	60	EC18D400B060W	267250	5
								120	EC18A400B120	267194	72	EC18D400B072W	267251	5
								208	EC18A400B208	267195	110	EC18D400B110W	267252	5
								230	EC18A400B230	267196	125	EC18D400B125W	267253	5
								240	EC18A400B240	267197	230	EC18D400B230W	267254	5
								400	EC18A400B400	267198	250	EC18D400B250W	267255	5
								440	EC18A400B440	267199	440	EC18D400B440W	267256	5
								480	EC18A400B480	267200				
								500	EC18A400B500	267201	24	EC18D400B024L	267257	5
								575	EC18A400B575	269082	48	EC18D400B048L	267258	5
								600	EC18A400B600	267202	110	EC18D400B110L	267259	5
											230	EC18D400B230L	267260	5
45	25	17	29	32	39	6.5x10 <sup>5</sup>	4 0	12	EC25A400B012	267203	12	EC25D400B012W	267261	5
								24	EC25A400B024	267204	24	EC25D400B024W	267262	5
								42	EC25A400B042	267205	36	EC25D400B036W	267263	5
								48	EC25A400B048	267206	48	EC25D400B048W	267264	5
								110	EC25A400B110	267207	60	EC25D400B060W	267265	5
								120	EC25A400B120	267208	72	EC25D400B072W	267266	5
								208	EC25A400B208	267209	110	EC25D400B110W	267267	5
								230	EC25A400B230	267210	125	EC25D400B125W	267268	5
								240	EC25A400B240	267211	230	EC25D400B230W	267269	5
								400	EC25A400B400	267212	250	EC25D400B250W	267270	5
								440	EC25A400B440	267213	440	EC25D400B440W	267271	5
								480	EC25A400B480	267214				
								500	EC25A400B500	267215	24	EC25D400B024L	267272	5
								575	EC25A400B575	269083	48	EC25D400B048L	267273	5
								600	EC25A400B600	267216	110	EC25D400B110L	267274	5
											230	EC25D400B230L	267275	5
60	32	22.5	39.5	43	52	8x10 <sup>5</sup>	4 0	12	EC32A400B012	267217	12	EC32D400B012W	267276	1
								24	EC32A400B024	267218	24	EC32D400B024W	267277	1
								42	EC32A400B042	267219	36	EC32D400B036W	267278	1
								48	EC32A400B048	267220	48	EC32D400B048W	267279	1
								110	EC32A400B110	267221	60	EC32D400B060W	267280	1
								120	EC32A400B120	267222	72	EC32D400B072W	267281	1
								208	EC32A400B208	267223	110	EC32D400B110W	267282	1
								230	EC32A400B230	267224	125	EC32D400B125W	267283	1
								240	EC32A400B240	267225	230	EC32D400B230W	267284	1
								400	EC32A400B400	267226	250	EC32D400B250W	267285	1
								440	EC32A400B440	267227	440	EC32D400B440W	267286	1
								480	EC32A400B480	267228				
								500	EC32A400B500	267229	24	EC32D400B024L	267287	1
								575	EC32A400B575	269084	48	EC32D400B048L	267288	1
								600	EC32A400B600	267230	110	EC32D400B110L	267289	1
											230	EC32D400B230L	267290	1



Order codes

Intro

A

B

C

D

E

F

G

H

I

J/X

New

(1) End character: W = Wide voltage and built-in diode  
L = Low consumption



2NO - 2NC contactors - Double box terminals

Max. operating current		Admissible power AC3				Electrical endurance	Power cont.	Control circuit							
Not inductive load AC1 A	Motors <440V 3Ph 50/60Hz AC3 A	220-230V	380-400V	440V	500V	Cat. AC3 Operations	NO	NC	AC			DC			Pack
		kW HP	kW HP	kW HP	kW HP				Voltage	Cat. no.	Ref. no.	Voltage	Cat. no. <sup>(1)</sup>	Ref. no.	
25	12	3 4	5.5 7.5	5.5 7.5	7.5 10	1.7x10 <sup>6</sup>	2	2	12	EC12AB00B012	267291	12	EC12DB00B012W	267347	5
							2	2	24	EC12AB00B024	267292	24	EC12DB00B024W	267348	5
							2	2	42	EC12AB00B042	267293	36	EC12DB00B036W	267349	5
							2	2	48	EC12AB00B048	267294	48	EC12DB00B048W	267350	5
							2	2	110	EC12AB00B110	267295	60	EC12DB00B060W	267351	5
							2	2	120	EC12AB00B120	267296	72	EC12DB00B072W	267352	5
							2	2	208	EC12AB00B208	267297	110	EC12DB00B110W	267353	5
							2	2	230	EC12AB00B230	267298	125	EC12DB00B125W	267354	5
							2	2	240	EC12AB00B240	267299	230	EC12DB00B230W	267355	5
							2	2	400	EC12AB00B400	267300	250	EC12DB00B250W	267356	5
							2	2	440	EC12AB00B440	267301	440	EC12DB00B440W	267357	5
							2	2	480	EC12AB00B480	267302				
							2	2	500	EC12AB00B500	267303	24	EC12DB00B024L	267358	5
							2	2	575	EC12AB00B575	269115	48	EC12DB00B048L	267359	5
							2	2	600	EC12AB00B600	267304	110	EC12DB00B110L	267360	5
													230	EC12DB00B230L	267361
32	18	4 5.5	7.5 10	7.5 10	10 13.5	1.5x10 <sup>6</sup>	2	2	12	EC18AB00B012	267305	12	EC18DB00B012W	267362	5
							2	2	24	EC18AB00B024	267306	24	EC18DB00B024W	267363	5
							2	2	42	EC18AB00B042	267307	36	EC18DB00B036W	267364	5
							2	2	48	EC18AB00B048	267308	48	EC18DB00B048W	267365	5
							2	2	110	EC18AB00B110	267309	60	EC18DB00B060W	267366	5
							2	2	120	EC18AB00B120	267310	72	EC18DB00B072W	267367	5
							2	2	208	EC18AB00B208	267311	110	EC18DB00B110W	267368	5
							2	2	230	EC18AB00B230	267312	125	EC18DB00B125W	267369	5
							2	2	240	EC18AB00B240	267313	230	EC18DB00B230W	267370	5
							2	2	400	EC18AB00B400	267314	250	EC18DB00B250W	267371	5
							2	2	440	EC18AB00B440	267315	440	EC18DB00B440W	267372	5
							2	2	480	EC18AB00B480	267316				
							2	2	500	EC18AB00B500	267317	24	EC18DB00B024L	267373	5
							2	2	575	EC18AB00B575	269116	48	EC18DB00B048L	267374	5
							2	2	600	EC18AB00B600	267318	110	EC18DB00B110L	267375	5
													230	EC18DB00B230L	267376
45	25	7.5 10	11 15	12 16	15 20	1.5x10 <sup>6</sup>	2	2	12	EC25AB00B012	267319	12	EC25DB00B012W	267377	5
							2	2	24	EC25AB00B024	267320	24	EC25DB00B024W	267378	5
							2	2	42	EC25AB00B042	267321	36	EC25DB00B036W	267379	5
							2	2	48	EC25AB00B048	267322	48	EC25DB00B048W	267380	5
							2	2	110	EC25AB00B110	267323	60	EC25DB00B060W	267381	5
							2	2	120	EC25AB00B120	267324	72	EC25DB00B072W	267382	5
							2	2	208	EC25AB00B208	267325	110	EC25DB00B110W	267383	5
							2	2	230	EC25AB00B230	267326	125	EC25DB00B125W	267384	5
							2	2	240	EC25AB00B240	267327	230	EC25DB00B230W	267385	5
							2	2	400	EC25AB00B400	267328	250	EC25DB00B250W	267386	5
							2	2	440	EC25AB00B440	267329	440	EC25DB00B440W	267387	5
							2	2	480	EC25AB00B480	267330				
							2	2	500	EC25AB00B500	267331				
							2	2	575	EC25AB00B575	269117				
							2	2	600	EC25AB00B600	267332				
							60	32	9 12	15 22	15 22	18 25	1.5x10 <sup>6</sup>	2	2
2	2	24	EC32AB00B024	267334	24	EC32DB00B024W								267393	1
2	2	42	EC32AB00B042	267335	36	EC32DB00B036W								267394	1
2	2	48	EC32AB00B048	267336	48	EC32DB00B048W								267395	1
2	2	110	EC32AB00B110	267337	60	EC32DB00B060W								267396	1
2	2	120	EC32AB00B120	267338	72	EC32DB00B072W								267397	1
2	2	208	EC32AB00B208	267339	110	EC32DB00B110W								267398	1
2	2	230	EC32AB00B230	267340	125	EC32DB00B125W								267399	1
2	2	240	EC32AB00B240	267341	230	EC32DB00B230W								267400	1
2	2	400	EC32AB00B400	267342	250	EC32DB00B250W								267401	1
2	2	440	EC32AB00B440	267343	440	EC32DB00B440W								267402	1
2	2	480	EC32AB00B480	267344											
2	2	500	EC32AB00B500	267345											
2	2	575	EC32AB00B575	269118											
2	2	600	EC32AB00B600	267346											

(1) End character: W = Wide voltage and built-in diode  
L = Low consumption

Global contactors

Intro

A

B

C

D

E

F

G

H

I

J/X



New

Auxiliary contactors - Double box terminals - Ith 20A



Contacts		Control circuit						
NO •3  •4	NC  •1  •2	AC			DC			Pack
		Voltage	Cat. no.	Ref. no.	Voltage	Cat. no. <sup>(1)</sup>	Ref. no.	
4	0	12	ECACA440B012	268140	12	ECACD440B012W	268210	5
4	0	24	ECACA440B024	268141	24	ECACD440B024W	268211	5
4	0	42	ECACA440B042	268142	36	ECACD440B036W	268212	5
4	0	48	ECACA440B048	268143	48	ECACD440B048W	268213	5
4	0	110	ECACA440B110	268144	60	ECACD440B060W	268214	5
4	0	120	ECACA440B120	268145	72	ECACD440B072W	268215	5
4	0	208	ECACA440B208	268146	110	ECACD440B110W	268216	5
4	0	230	ECACA440B230	268147	125	ECACD440B125W	268217	5
4	0	240	ECACA440B240	268148	230	ECACD440B230W	268218	5
4	0	400	ECACA440B400	268149	250	ECACD440B250W	268219	5
4	0	440	ECACA440B440	268150	400	ECACD440B440W	268220	5
4	0	480	ECACA440B480	268151				
4	0	500	ECACA440B500	268152	24	ECACD440B024L	268221	5
4	0	575	ECACA440B575	268673	48	ECACD440B048L	268222	5
4	0	600	ECACA440B600	268153	110	ECACD440B110L	268223	5
4	0				230	ECACD440B230L	268224	5
3	1	12	ECACA431B012	268154	12	ECACD431B012W	268225	5
3	1	24	ECACA431B024	268155	24	ECACD431B024W	268226	5
3	1	42	ECACA431B042	268156	36	ECACD431B036W	268227	5
3	1	48	ECACA431B048	268157	48	ECACD431B048W	268228	5
3	1	110	ECACA431B110	268158	60	ECACD431B060W	268229	5
3	1	120	ECACA431B120	268159	72	ECACD431B072W	268230	5
3	1	208	ECACA431B208	268160	110	ECACD431B110W	268231	5
3	1	230	ECACA431B230	268161	125	ECACD431B125W	268232	5
3	1	240	ECACA431B240	268162	230	ECACD431B230W	268233	5
3	1	400	ECACA431B400	268163	250	ECACD431B250W	268234	5
3	1	440	ECACA431B440	268164	400	ECACD431B440W	268235	5
3	1	480	ECACA431B480	268165				
3	1	500	ECACA431B500	268166	24	ECACD431B024L	268236	5
3	1	575	ECACA431B575	268674	48	ECACD431B048L	268237	5
3	1	600	ECACA431B600	268167	110	ECACD431B110L	268238	5
3	1				230	ECACD431B230L	268239	5
2	2	12	ECACA422B012	268168	12	ECACD422B012W	268240	5
2	2	24	ECACA422B024	268169	24	ECACD422B024W	268241	5
2	2	42	ECACA422B042	268170	36	ECACD422B036W	268242	5
2	2	48	ECACA422B048	268171	48	ECACD422B048W	268243	5
2	2	110	ECACA422B110	268172	60	ECACD422B060W	268244	5
2	2	120	ECACA422B120	268173	72	ECACD422B072W	268245	5
2	2	208	ECACA422B208	268174	110	ECACD422B110W	268246	5
2	2	230	ECACA422B230	268175	125	ECACD422B125W	268247	5
2	2	240	ECACA422B240	268176	230	ECACD422B230W	268248	5
2	2	400	ECACA422B400	268177	250	ECACD422B250W	268249	5
2	2	440	ECACA422B440	268178	400	ECACD422B440W	268250	5
2	2	480	ECACA422B480	268179				
2	2	500	ECACA422B500	268180	24	ECACD422B024L	268251	5
2	2	575	ECACA422B575	268675	48	ECACD422B048L	268252	5
2	2	600	ECACA422B600	268181	110	ECACD422B110L	268253	5
2	2				230	ECACD422B230L	268254	5
1	3	12	ECACA413B012	268182	12	ECACD413B012W	268400	5
1	3	24	ECACA413B024	268183	24	ECACD413B024W	268401	5
1	3	42	ECACA413B042	268184	36	ECACD413B036W	268402	5
1	3	48	ECACA413B048	268185	48	ECACD413B048W	268403	5
1	3	110	ECACA413B110	268186	60	ECACD413B060W	268404	5
1	3	120	ECACA413B120	268187	72	ECACD413B072W	268405	5
1	3	208	ECACA413B208	268188	110	ECACD413B110W	268406	5
1	3	230	ECACA413B230	268189	125	ECACD413B125W	268407	5
1	3	240	ECACA413B240	268190	230	ECACD413B230W	268408	5
1	3	400	ECACA413B400	268191	250	ECACD413B250W	268409	5
1	3	440	ECACA413B440	268192	400	ECACD413B440W	268410	5
1	3	480	ECACA413B480	268193				
1	3	500	ECACA413B500	268194	24	ECACD413B024L	268411	5
1	3	575	ECACA413B575	268676	48	ECACD413B048L	268412	5
1	3	600	ECACA413B600	268195	110	ECACD413B110L	268413	5
1	3				230	ECACD413B230L	268414	5
0	4	12	ECACA404B012	268196	12	ECACD404B012W	268270	5
0	4	24	ECACA404B024	268197	24	ECACD404B024W	268271	5
0	4	42	ECACA404B042	268198	36	ECACD404B036W	268272	5
0	4	48	ECACA404B048	268199	48	ECACD404B048W	268273	5
0	4	110	ECACA404B110	268200	60	ECACD404B060W	268274	5
0	4	120	ECACA404B120	268201	72	ECACD404B072W	268275	5
0	4	208	ECACA404B208	268202	110	ECACD404B110W	268276	5
0	4	230	ECACA404B230	268203	125	ECACD404B125W	268277	5
0	4	240	ECACA404B240	268204	230	ECACD404B230W	268278	5
0	4	400	ECACA404B400	268205	250	ECACD404B250W	268279	5
0	4	440	ECACA404B440	268206	400	ECACD404B440W	268280	5
0	4	480	ECACA404B480	268207				
0	4	500	ECACA404B500	268208	24	ECACD404B024L	268281	5
0	4	575	ECACA404B575	268677	48	ECACD404B048L	268282	5
0	4	600	ECACA404B600	268209	110	ECACD404B110L	268283	5
0	4				230	ECACD404B230L	268284	5

(1) End character: **W** = Wide voltage and built-in diode  
**L** = Low consumption

Catalogue number structure

Example: ECACA440B012

**EC:** Means Efficor Contactor range

**AC:** Auxiliary Contact

**A:** A stands for AC

**D:** D stands for DC

**4:** Available contacts

**40** 4NO/0NC

**31** 3NO/1NC

**22** 2NO/2NC

**13** 1NO/3NC

**04** 0NO/4NC

**B:** Type of terminal

**B** stands for Box terminal

**R** stands for Ring terminal

**012:** Coil voltage (012 up to 600V)

Order codes

Intro

A

B

C

D

E

F

G

H

I

J/X



New

Spare coils for contactors and auxiliary contactors - Box clamp terminals

	Voltage	Use for	Cat. no.	Ref. no.	Pack	
AC coil Voltage in AC 50/60Hz 	12Vac	EC09A...EC18A, ECACA...B	ECCS1A012S	268687	5	
	24Vac	EC09A...EC18A, ECACA...B	ECCS1A024S	268688	5	
	42Vac	EC09A...EC18A, ECACA...B	ECCS1A042S	268689	5	
	48Vac	EC09A...EC18A, ECACA...B	ECCS1A048S	268690	5	
	110Vac	EC09A...EC18A, ECACA...B	ECCS1A110S	268691	5	
	120Vac	EC09A...EC18A, ECACA...B	ECCS1A120S	268692	5	
	208Vac	EC09A...EC18A, ECACA...B	ECCS1A208S	268693	5	
	230Vac	EC09A...EC18A, ECACA...B	ECCS1A230S	268694	5	
	240Vac	EC09A...EC18A, ECACA...B	ECCS1A240S	268695	5	
	400Vac	EC09A...EC18A, ECACA...B	ECCS1A400S	268696	5	
	440Vac	EC09A...EC18A, ECACA...B	ECCS1A440S	268697	5	
	480Vac	EC09A...EC18A, ECACA...B	ECCS1A480S	268698	5	
	500Vac	EC09A...EC18A, ECACA...B	ECCS1A500S	268699	5	
	575Vac	EC09A...EC18A, ECACA...B	ECCS1A575S	268984	5	
	600Vac	EC09A...EC18A, ECACA...B	ECCS1A600S	268700	5	
	DC Wide Voltage range (W) Operating range: +25% Un -30% Un	12Vdc	EC09D...EC18D, ECACD...B	ECCS1D012S	268701	5
		24Vdc	EC09D...EC18D, ECACD...B	ECCS1D024S	268702	5
36Vdc		EC09D...EC18D, ECACD...B	ECCS1D036S	268703	5	
48Vdc		EC09D...EC18D, ECACD...B	ECCS1D048S	268704	5	
60Vdc		EC09D...EC18D, ECACD...B	ECCS1D060S	268705	5	
72Vdc		EC09D...EC18D, ECACD...B	ECCS1D072S	268706	5	
110Vdc		EC09D...EC18D, ECACD...B	ECCS1D110S	268707	5	
125Vdc		EC09D...EC18D, ECACD...B	ECCS1D125S	268708	5	
230Vdc		EC09D...EC18D, ECACD...B	ECCS1D230S	268709	5	
250Vdc		EC09D...EC18D, ECACD...B	ECCS1D250S	268710	5	
440Vdc		EC09D...EC18D, ECACD...B	ECCS1D440S	268711	5	
DC Low Consumption (L) VDC < 3.3W for EC09 up to EC18	24Vdc	EC09D...EC18D, ECACD...B	ECCS1D024SL	268712	5	
	48Vdc	EC09D...EC18D, ECACD...B	ECCS1D048SL	268713	5	
	110Vdc	EC09D...EC18D, ECACD...B	ECCS1D110SL	268714	5	
	230Vdc	EC09D...EC18D, ECACD...B	ECCS1D230SL	268715	5	
AC coil Voltage in AC 50/60Hz 	12Vac	EC25A...EC40A...B	ECCS2A012S	268716	5	
	24Vac	EC25A...EC40A...B	ECCS2A024S	268717	5	
	42Vac	EC25A...EC40A...B	ECCS2A042S	268718	5	
	48Vac	EC25A...EC40A...B	ECCS2A048S	268719	5	
	110Vac	EC25A...EC40A...B	ECCS2A110S	268720	5	
	120Vac	EC25A...EC40A...B	ECCS2A120S	268721	5	
	208Vac	EC25A...EC40A...B	ECCS2A208S	268722	5	
	230Vac	EC25A...EC40A...B	ECCS2A230S	268723	5	
	240Vac	EC25A...EC40A...B	ECCS2A240S	268724	5	
	400Vac	EC25A...EC40A...B	ECCS2A400S	268725	5	
	440Vac	EC25A...EC40A...B	ECCS2A440S	268726	5	
	480Vac	EC25A...EC40A...B	ECCS2A480S	268727	5	
	500Vac	EC25A...EC40A...B	ECCS2A500S	268728	5	
	575Vac	EC25A...EC40A...B	ECCS2A575S	268985	5	
	600Vac	EC25A...EC40A...B	ECCS2A600S	268729	5	
	DC Wide Voltage range (W) Operating range: +25% Un -30% Un	12Vdc	EC25AD...EC40D...B	ECCS2D012S	268730	5
		24Vdc	EC25AD...EC40D...B	ECCS2D024S	268731	5
36Vdc		EC25AD...EC40D...B	ECCS2D036S	268732	5	
48Vdc		EC25AD...EC40D...B	ECCS2D048S	268733	5	
60Vdc		EC25AD...EC40D...B	ECCS2D060S	268734	5	
72Vdc		EC25AD...EC40D...B	ECCS2D072S	268735	5	
110Vdc		EC25AD...EC40D...B	ECCS2D110S	268736	5	
125Vdc		EC25AD...EC40D...B	ECCS2D125S	268737	5	
230Vdc		EC25AD...EC40D...B	ECCS2D230S	268738	5	
250Vdc		EC25AD...EC40D...B	ECCS2D250S	268739	5	
440Vdc		EC25AD...EC40D...B	ECCS2D440S	268740	5	
DC Low Consumption (L) VDC < 5.5W for EC25 up to EC40	24Vdc	EC25AD...EC40D...B	ECCS2D024SL	268741	5	
	48Vdc	EC25AD...EC40D...B	ECCS2D048SL	268742	5	
	110Vdc	EC25AD...EC40D...B	ECCS2D110SL	268743	5	
	230Vdc	EC25AD...EC40D...B	ECCS2D230SL	268744	5	

Global contactors

Intro

A

B

C

D

E

F

G

H

I

J/X



Accessories for contactors

Auxiliary contact blocks

	Contacts				Box clamp terminals		Pack
	NO	NC	NO EM	NC EM	Cat. no.	Ref. no.	
	•3  •4	•1  •2	•7  •8	•5  •6			

Frontal auxiliary blocks

	<b>2 contacts</b>						
	1	1	-	-	ECFA211S	268872	5
	2	0	-	-	ECFA220S	268873	5
	0	2	-	-	ECFA202S	268874	5
	<b>4 contacts</b>						
	4	0	-	-	ECFA440S	268881	5
	3	1	-	-	ECFA431S	268882	5
	2	2	-	-	ECFA422S	268883	5
	1	3	-	-	ECFA413S	268884	5
	0	4	-	-	ECFA404S	268885	5
1	1	1	1	ECFA422SE	268886	5	

Lateral auxiliary blocks

	<b>Contact block</b>						
	2	0	-	-	ECLA220S	268899	10
	1	1	-	-	ECLA211S	268900	10
	0	2	-	-	ECLA202S	268901	10
	<b>Mechanical interlock</b>						
	0	0	-	-	ECMI	268908	10
	0	2	-	-	ECMI02S	268910	10

Pneumatic timer<sup>(1)</sup>

	NO	NC	Time	Type	Box clamp terminals		Pack
					Cat. no.	Ref. no.	
	•7  •8	•5  •6					
	1	1	0.1-30 s	delay ON	ECPT30SC	268913	5
	1	1	1-60 s	delay ON	ECPT60SC	268914	5
	1	1	0.1-30 s	delay OFF	ECPT30SD	268916	5
	1	1	1-60 s	delay OFF	ECPT60SD	268917	5

All accessories can be used with all type of contactors.  
 (1) Use only with contactor coil in AC voltage.

Order codes

Intro

A

B

C

D

E

F

G

H

I

J/X

Accessories for contactors (continued)

Mechanical latch

NC	Use with	Coil voltage 50/60HZ	Coil voltage DC	Box clamp terminals		Pack
				Cat. no.	Ref. no.	
	EC09A up to EC18A, ECACA	24-32V	-	ECML1AS032	268919	5
	EC09A up to EC18A, ECACA	42-60V	-	ECML1AS060	268920	5
	EC09A up to EC18A, ECACA	110-127V	-	ECML1AS127	268921	5
	EC09A up to EC18A, ECACA	220-240V	-	ECML1AS277	268922	5
	EC09A up to EC18A, ECACA	380-480V	-	ECML1AS480	268923	5
	EC09A up to EC18A, ECACA	500-690V	-	ECML1AS660	268924	5
	EC25A up to EC40A	24-32V	-	ECML2AS032	268925	5
	EC25A up to EC40A	42-60V	-	ECML2AS060	268926	5
	EC25A up to EC40A	110-127V	-	ECML2AS127	268927	5
	EC25A up to EC40A	220-240V	-	ECML2AS277	268928	5
	EC25A up to EC40A	380-480V	-	ECML2AS480	268929	5
	EC25A up to EC40A	500-690V	-	ECML2AS660	268930	5
	EC09D up to EC18D, ECACD	-	24-36V	ECML1DS036	269325 <sup>(1)</sup>	5
	EC09D up to EC18D, ECACD	-	42-48V	ECML1DS048	269326 <sup>(1)</sup>	5
	EC09D up to EC18D, ECACD	-	60-72V	ECML1DS072	269327 <sup>(1)</sup>	5
	EC09D up to EC18D, ECACD	-	110-277V	ECML1DS177	269328 <sup>(1)</sup>	5
	EC09D up to EC18D, ECACD	-	220-250V	ECML1DS250	269329 <sup>(1)</sup>	5
	EC09D up to EC18D, ECACD	-	440V	ECML1DS440	269330 <sup>(1)</sup>	5
EC25D up to EC40D	-	24-36V	ECML2DS036	269331 <sup>(1)</sup>	5	
EC25D up to EC40D	-	42-48V	ECML2DS048	269332 <sup>(1)</sup>	5	
EC25D up to EC40D	-	60-72V	ECML2DS072	269333 <sup>(1)</sup>	5	
EC25D up to EC40D	-	110-277V	ECML2DS277	269334 <sup>(1)</sup>	5	
EC25D up to EC40D	-	220-250V	ECML2DS250	269335 <sup>(1)</sup>	5	
EC25D up to EC40D	-	440V	ECML2DS440	269336 <sup>(1)</sup>	5	

(1) No use with DC version low consumption

Surge suppressor (plug-in)



Description	Suppressor type	Voltage	Cat. no.	Ref. no.	Pack
Diode type, DC 12-440V	DI	DC	ECSUDI440	268931	10
RC type, AC 24-48V	RC	AC	ECSURC048	268932	10
RC type, AC 50-127V	RC	AC	ECSURC127	268933	10
RC type, AC 130-250V	RC	AC	ECSURC250	268934	10
RC type, AC 230-440V	RC	AC	ECSURC440	268935	10
RC type, AC 400-600V	RC	AC	ECSURC600	268936	10
Varistor type, AC/DC 24-48V	VA	AC/DC	ECSUVA048	268937	10
Varistor type, AC/DC 50-127V	VA	AC/DC	ECSUVA127	268938	10
Varistor type, AC/DC 130-250V	VA	AC/DC	ECSUVA250	268939	10
Varistor type, AC/DC 230-440V	VA	AC/DC	ECSUVA440	268940	10
Varistor type, AC/DC 400-600V	VA	AC/DC	ECSUVA600	268941	10



Global contactors  
Intro  
A  
B  
C  
D  
E  
F  
G  
H  
I  
J/X

Accessories for starters

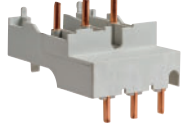
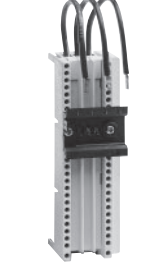
Fuseless starter kits

	Use with	Description	Cat. no.	Ref. no.	Pack
	GPS1 - EC09A up to EC25A	Link module	ECM1AL25	268954	5
	GPS1 - EC32A	Link module	ECM1AL32	268955	5
	GPS2 - EC32A and EC40A	Link module	ECM2AL40	268956	5
	GPS1 - EC09 up to EC25	25A - 60mm busbar adapter 45x200mm	PBF23EBDA	107152	4
	GPS2 - EC32 up to EC40	63A - 60mm busbar adapter 54x200	PBF23ECDA	107153	4
	EC09-EC40	45mm busbar adapter empty for reversing/star-delta application	ECBSRSD1	267403	4
	EC09-EC40	54mm busbar adapter empty for reversing/star-delta application	ECBSRSD2	267404	4
	EC09-EC40	9mm busbar adapter empty for contactor lateral blocks	ECBSLS	267405	10
		60mm universal busbar support	ECBS60S	267406	10
		Lateral protection for universal busbar support	ECBSLP	267407	10
	GPS1 - EC09 up to EC32	Base plate 45mm	ECBP45	268962	5
	GPS2 - EC32 and EC40	Base plate 55mm	ECBP55	268953	5

Wiring kits for reversing starters

	Use with	Description	Cat. no.	Ref. no.	Pack
	EC09A up to EC25A	Suitable to be used for upper and lower connections with and without overload relay <b>with</b> mechanical interlock	ECKS1RV	268948	1
	EC32A and EC40A	Suitable to be used for upper and lower connections with and without overload relay <b>with</b> mechanical interlock	ECKS2RV	268950	1

Wiring kits for star delta starters

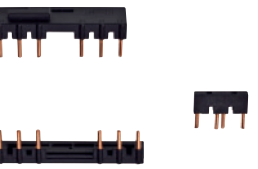
	Use with	Description	Cat. no.	Ref. no.	Pack
	EC09 up to EC25	Suitable to be used for upper and lower connections with and without overload relay	ECKS1YD	268951	1
	EC32 and EC40	Suitable to be used for upper and lower connections with and without overload relay	ECKS2YD	268952	1

Parallel busbar

	Use with	Description	Cat. no.	Ref. no.	Pack
	EC09 up to EC25	Parallel busbar for 2 contactors	ECBB1B2	268942	5
	EC32 and EC40	Parallel busbar for 2 contactors	ECBB2B2	268945	5

Parallel poles

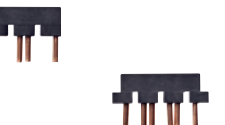
	Use with	Description	Cat. no.	Ref. no.	Pack
	EC09 up to EC25	3 poles in parallel	EC3PP1B	268943	6
	EC09 up to EC25	4 poles in parallel	EC4PP1B	268944	6
	EC32 and EC40	3 poles in parallel	EC3PP2B	268946	6
	EC32 and EC40	4 poles in parallel	EC4PP2B	268947	6

Order codes

Intro

A

B

C

D

E

F

G

H

I

J/X



New

Thermal overload relays

Thermal overload relays

Trip class 10	Setting range		Fuses		Use with	Box clamp terminals		
	Min. A	Max. A	AM A	gL-gG A		Cat. no.	Ref. no.	Pack
	0.16	0.26	2	2		ECRT1B10B	268996	5
	0.25	0.41	2	2		ECRT1B10C	268997	5
	0.40	0.65	2	2		ECRT1B10D	268998	5
	0.65	1.10	2	4		ECRT1B10F	268999	5
	1.00	1.50	4	6		ECRT1B10G	269000	5
	1.30	1.90	4	6	EC09	ECRT1B10H	269001	5
	1.80	2.70	6	10	EC12	ECRT1B10J	269002	5
	2.50	4.00	8	16		ECRT1B10K	269003	5
	4.00	6.30	12	20	EC18	ECRT1B10L	269004	5
	5.50	8.50	16	20		ECRT1B10M	269005	5
	8.00	12.00	20	25		ECRT1B10N	269006	5
	10.00	16.00	25	35		ECRT1B10P	269007	5
	14.50	18.00	32	50		ECRT1B10S	269008	5
	17.50	22.00	40	63		ECRT1B10T	269009	5
	8.00	12.00	20	25		ECRT2B10N	268103	5
	10.00	16.00	25	35		ECRT2B10P	268104	5
	14.50	18.00	32	50	EC25	ECRT2B10S	268105	5
	17.50	22.00	40	63	EC32	ECRT2B10T	268106	5
	21.00	26.00	40	63	EC40	ECRT2B10U	268107	5
	25.00	32.00	50	80		ECRT2B10V	268108	5
	30.00	40.00	63	100		ECRT2B10W	268109	5



Accessories

Use with	Description	Cat. no.	Ref. no.	Pack
<b>Base for separate mounting</b>				
ECRT1	DIN EN500022-35	ECRT1BS	268963	1
ECRT2	DIN EN500022-35	ECRT2BS	268964	1
<b>Push-button with flexible cable</b>				
ECRT1	0.5 m	RTXS	113855	1
	1 m	RTXSL	113856	1
	backside reset	RTXBS	108864	1
<b>Remote electrical reset</b>				
ECRT1 and ECRT2	12 VAC/DC	RTXRRB	113661	1
	24 VAC/DC	RTXRRD	113662	1
	48 VAC/DC	RTXRRG	113663	1
	110-240VAC/DC	RTXRRJ	113664	1
	220/415VAC/DC	RTXRRN	113665	1
	380/480VAC/DC	RTXRRU	113666	1



Global contactors

Intro

A

B

C

D

E

F

G

H

I

J/X



New

### Conformity to standards

IEC/EN 60947-1	GB14048.4
IEC/EN 60947-4-1	UL508
IEC/EN 60947-5-1	UL486E
IEC/EN 60947-5-4	CSA2.22-14
EN50011	NF F16 101/102
EN50012	
EN50005	

### Approvals/Marking

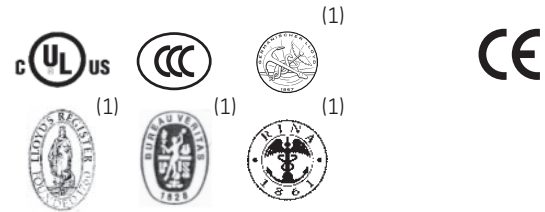

(1) In progress

### Ambient conditions

Storage temperature	-55°C to +80°C
Operation temperature	-40°C to +55°C
	-40°C to +70°C <sup>(1)</sup>
Altitude	<2000m

(1) From 100% to 110% of rated control voltage, without additional auxiliary blocks

### Climatic resistance (IEC 68-2)

<b>Continuous tests 40 / 125 / 56</b>	
<b>Cold (72h)</b>	Temperature -40°C
<b>Dry heat (96h)</b>	Temperature +125°C Relative humidity < 50%
<b>Humid heat (56h)</b>	Temperature +40°C Relative humidity 95%
<b>Cyclic tests (6 cycles)</b>	
	Humid heat
<b>First half-cycle</b>	Low temperature +25°C Relative humidity 93%
<b>Second half-cycle</b>	Low temperature +55°C Relative humidity 95°C

### Mounting positions

#### Installation capabilities

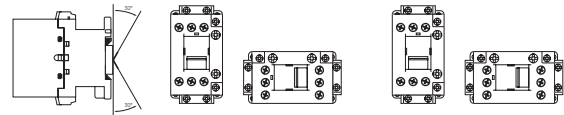

#### With de-rating values

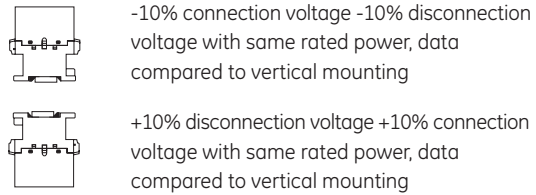

### Terminal capacity and tightening torque

Conventional Thermal Current (Ith)		(A)	Head type	EC09 - EC18	EC25	EC32 - EC40
<b>Box terminals</b>						
	Solid, stranded and finely stranded w/o end sleeve	(mm²)	Slot & P22	32	45	60
	Finely stranded with end sleeve	(mm²)	Slot & P22	0.75...6	0.75...10	0.75...16
	Finely stranded w/o end sleeve	(mm²)	Slot & P22	0.75...6	0.75...10	0.75...16
	AWG wires			18...10	18..8	18..6
	Tightening torque	(Nm) (Lb x in.)		2.2 / 20	2.2 / 20	2.2 / 20
	Finely stranded w/o end sleeve	(mm²)	Slot & P22	0.75...6	0.75...10	0.75...16
	AWG wires			18...10	18..8	18..6
	Tightening torque	(Nm) (Lb x in.)		2.2 / 20	2.2 / 20	2.2 / 20
	Finely stranded with end sleeve	(mm²)	Slot & P22	0.75...6	0.75...10	0.75...16
	AWG wires			18...10	18..8	18..6
	Tightening torque	(Nm) (Lb x in.)		2.2 / 20	2.2 / 20	2.2 / 20

Technical data

Intro

A

B

C

D

E

F

G

H

I

J/X



New

Electrical endurance

Category AC1 (3P & 4P contactors)

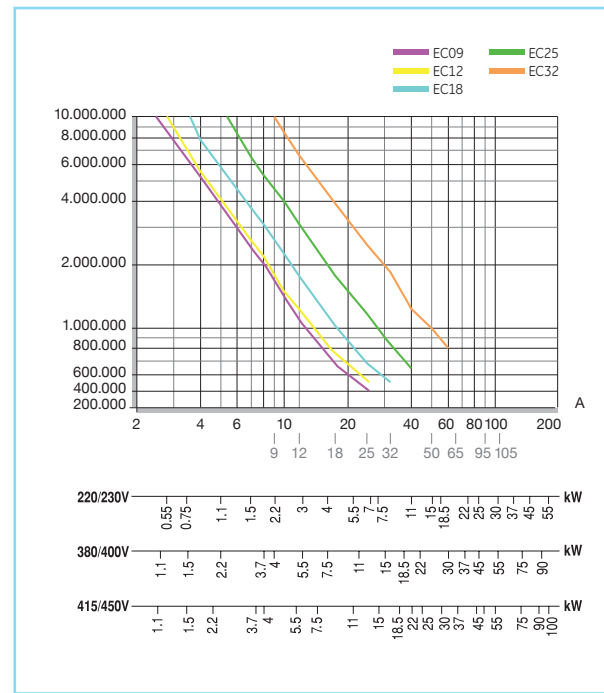

Category AC3 (3P contactors)

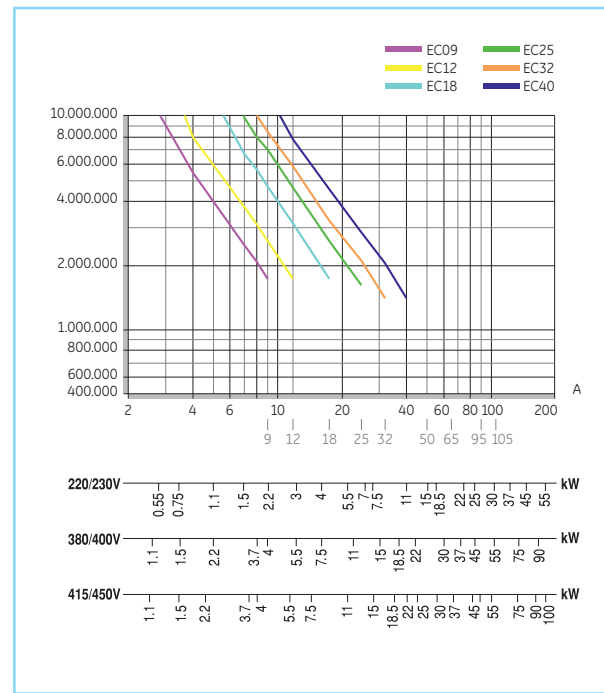

Category AC4 (3P contactors)

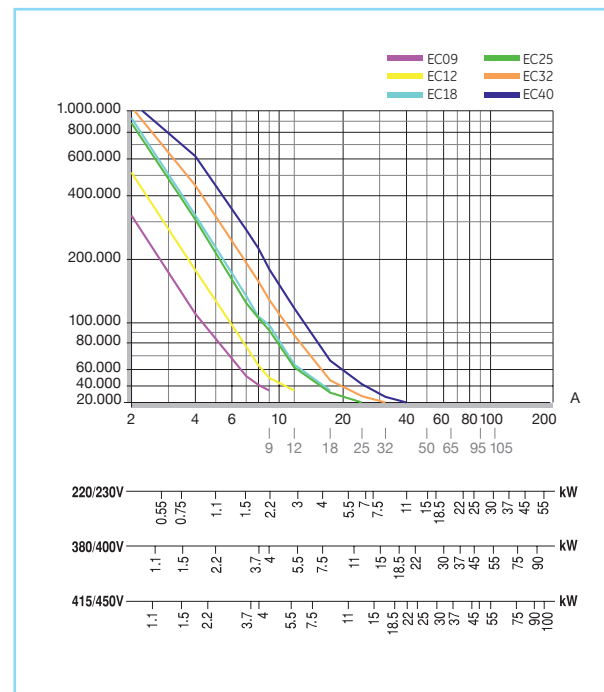

Power circuit

		EC 09	EC 12	EC18	EC 25	EC 32	EC 40
<b>Three pole version</b>							
Rated thermal current I <sub>th</sub> at θ ≤ 55°C	(A)	25	25	32	45	60	60
Rated operational current I <sub>e</sub> AC-3	(A)	9	12	18	25	32	40
Rated operational voltage U <sub>e</sub>	(V)	690V acc. IEC 60947-4-1 / 600V acc. UL-CSA					
<b>Four pole version</b>							
Rated thermal current I <sub>th</sub> at θ ≤ 55°C	(A)	-	25	32	45	60	-
Rated operational voltage U <sub>e</sub>	(V)	690V acc. IEC 60947-4-1 / 600V acc. UL-CSA					
<b>Three and four pole version</b>							
Rated insulation voltage U <sub>i</sub>	(V)	1000V acc. IEC 60947-4-1 / 600V acc. UL-CSA					
Maximum continuous current AC-1	(A)	25	25	32	45	60	60
Frequency limits	(Hz)	25..400	25..400	25..400	25..400	25..400	25..400
Making capacity (RMS) (IEC- 60947) U = 500V	(A)	220	220	220	315	520	520
<b>Breaking capacity (RMS) (acc. IEC-60947)</b>							
U <sub>e</sub> = 500V	(A)	220	220	220	315	520	520
U <sub>e</sub> = 690V	(A)	120	120	120	144	232	232
<b>Short-time current from cold state</b>							
1s	(A)	570	570	570	790	1265	1265
5s	(A)	254	254	254	355	565	565
10s	(A)	180	180	180	250	400	400
30s	(A)	104	104	104	145	231	231
1min	(A)	74	74	74	102	164	164
3min	(A)	42	42	42	60	95	95
Recovery time	(min)	10	10	10	10	10	10
<b>Protection against short-circuit with fuses without thermal overload relay</b>							
<b>Coordination type 1</b>							
gL-gG (U = 500V, 50kA or U = 415V, 80kA)	(A)	40	40	50	63	80	80
<b>Coordination type 2</b>							
gL-gG (U = 500V, 50kA or U = 415V, 80kA)	(A)	25	35	40	50	63	80
Average Impedance per pole	(mΩ)	2.25	2.25	2.25	1.6	1.2	1.2
<b>Power dissipation per pole</b>							
AC-1	(W)	1.41	1.41	2.30	3.24	4.32	4.32
AC-3	(W)	0.18	0.32	0.73	1.00	1.23	1.92
<b>Insulation resistance</b>							
Between adjacent poles	(MΩ)	>10	>10	>10	>10	>10	>10
Between poles and earth	(MΩ)	>10	>10	>10	>10	>10	>10
Between input and output	(MΩ)	>10	>10	>10	>10	>10	>10

Technical data

Intro

A

B

C

D

E

F

G

H

I

J/X



New

**Control circuit - Alternating current**

		EC09 up to EC18	EC25 up to EC40
Rated insulation voltage Ui	(V)	1000	1000
Standard voltages Us 50Hz	(V)	12-600	12-600
Standard voltages Us 60Hz	(V)	12-600	12-600
<b>Voltage operating limits 50/60Hz coils</b>			
Operating 50Hz xUs		0.8 - 1.1	0.8 - 1.1
Operating 60Hz xUs		0.85 - 1.1	0.85 - 1.1
Pick-up 50Hz xUs		0.5...0.8	0.6...0.8
Pick-up 60Hz xUs		0.85 - 1.1	0.85 - 1.1
Drop out 50Hz xUs		0.35...0.55	0.30...0.55
Drop out 60Hz xUs		0.35...0.55	0.30...0.55
<b>Maximum consumption bifrequency coils (cold state)</b>			
Magnetic circuit closed (50Hz/60Hz)	(VA)	9.8 / 6.8	11.4 / 7.6
Magnetic circuit opened (50Hz/60Hz)	(VA)	70.1 / 68.2	144 / 138
<b>Power factor</b>			
Magnetic circuit closed cos φ		0.24	0.20
Magnetic circuit opened cos φ		0.85	0.70
<b>Opening and closing times</b>			
Values between +10% Us and -20% Us			
Making time on energisation (NO)	(ms)	10 - 25	10 - 25
Breaking time on de-energisation (NO)	(ms)	5 - 15	5 - 15
Values at Us			
Making time on energisation (NO)	(ms)	10 - 25	10 - 25
Making time on de-energisation (NO)	(ms)	5 - 15	5 - 15
<b>Mechanical endurance</b>			
Bifrequency coils (at 50Hz)	10 <sup>6</sup> ops.	10	10
Maximum rate			
AC-1 at rated power	ops./h	1200	1200
AC-2 at rated power	ops./h	1200	1000
AC-3 at rated power	ops./h	1200	1000
AC-4 at rated power	ops./h	360	240
No load	ops./h	7200	7200

**Control circuit - Direct current**

		Coils with Wide voltage range		Coils with Low consumption	
		EC09 up to EC18	EC25 up to EC40	EC09 up to EC18	EC25 up to EC40
Rated insulation voltage Ui	(V)	1000	1000	1000	1000
Standard voltages Us DC	(V)	12 - 400	12 - 400	12 - 400	12 - 400
<b>Operating Limits</b>					
Operating xUs	(VDC)	0.70 - 1.25	0.70 - 1.25	0.80 - 1.1	0.80 - 1.1
Pick Up xUs	(VDC)	0.45 - 0.65	0.45 - 0.65	0.48 - 0.68	0.48 - 0.68
Drop Out xUs	(VDC)	0.12 - 0.30	0.12 - 0.30	0.12 - 0.30	0.12 - 0.30
<b>Maximum consumption at Us</b>					
Magnet circuit open and closed (cold state)	(W)	7.5	9.5	3.6	5.5
<b>Opening and closing times</b>					
Values between +10% Us and -20% Us					
Making time on energisation (NO)	(ms)	33 - 78	35 - 154	47 - 173	48 - 96
Breaking time on de-energisation (NO)	(ms)	14 - 18	15 - 26	12 - 15	8 - 26
Values at Us					
Making time on energisation (NO)	(ms)	33 - 78	35 - 66	44 - 83	33 - 75
Breaking time on de-energisation (NO)	(ms)	14 - 18	15 - 24	13 - 20	12 - 24
<b>Mechanical endurance</b>					
	10 <sup>6</sup> ops.	10	10	10	10
Maximum rate					
AC-1 at rated power	ops./h	1200	1200	1200	1200
AC-2 at rated power	ops./h	1200	1000	1200	1000
AC-3 at rated power	ops./h	1200	1000	1200	1000
AC-4 at rated power	ops./h	360	240	360	240
No load	ops./h	7200	7200	7200	7200

(1) 4.4 for 230 Vdc version



### Built-in auxiliary contacts

		EC09 up to EC25
Rated insulation voltage UI according to IEC 60947	(V)	1000
Rated thermal current Ith at $\theta \leq 55^\circ\text{C}$	(A)	10
<b>Making capacity (r.m.s.) acc. to IEC 60947</b>		
AC-15 $U_e \leq 400\text{V}$ , 50/60Hz	(A)	105
DC-13 $U_e \leq 220\text{Vdc}$	(A)	105
<b>Breaking capacity (r.m.s.) acc. to IEC 60947</b>		
AC-15 $U_e \leq 400\text{V}$ , 50/60Hz	(A)	105
DC-13 $U_e \leq 220\text{Vdc}$	(A)	2
<b>AC-15</b> rated voltage and current $U_e$ - $I_e$ according to IEC	(V-A)	110/120-10
		220/230-10
		380/400-6
		415/450-5
		500-4
		690/660-2
according to UL, CSA		A600
<b>DC-13</b> rated voltage and current $U_e$ - $I_e$ according to IEC	(V-A)	24-6
		48-4
		110-2
		220-0.7
		440-0.35
according to UL, CSA		Q600
Electrical endurance	$10^6$ ops.	0.2
Minimum operational power (operational safety)		17 V - 5mA
Short-circuit protection Max. fuse class gl-gG without welding	(A)	10
Insulation resistance	Between contacts	(M $\Omega$ )
	Between contacts and earth	(M $\Omega$ )
<b>Guaranteed no overlap between NO and NC contacts</b>		
Space		1.3mm
Impedance of the contacts	(M $\Omega$ )	2.7

### Auxiliary contact blocks

		ECFA/ECLA
Rated insulation voltage UI according to IEC 60947	(V)	1000
Rated thermal current Ith at $\theta \leq 55^\circ\text{C}$	(A)	10
<b>Making capacity (Ieff) according to IEC 60947</b>		
AC-15 $U_e \leq 400\text{V}$ , 50/60Hz	(A)	60
DC-13 $U_e \leq 220\text{Vdc}$	(A)	60
<b>Breaking capacity (Ieff) according to IEC 60947</b>		
AC-15 $U_e \leq 400\text{V}$ , 50/60Hz	(A)	60
DC-13 $U_e \leq 220\text{V}$ , DC	(A)	0.95
<b>AC-15</b> rated voltage and current $U_e$ - $I_e$ according to IEC	(V-A)	110/120-6
		220/230-6
		380/400-4
		415/450-3.5
		500-2.5
		690/660-1.5
according to UL, CSA		A600
<b>DC-13</b> rated voltage and current $U_e$ - $I_e$ according to IEC	(V-A)	24-4
		48-2
		110-0.7
		220-0.3
		440-0.15
according to UL, CSA		Q600
Electrical endurance	$10^6$ ops.	0.2
Mechanical endurance	$10^6$ ops.	10
Minimum operational current (operational safety)		17-5 V-mA
Short-circuit protection Max. fuse class gl-gG without welding	(A)	10
Insulation resistance	Between contacts	(M $\Omega$ )
	Between contacts and earth	(M $\Omega$ )
<b>Guaranteed no overlap between NO and NC contacts</b>		
Space		1.6mm for ECFA / 2.2mm for ECLA
Impedance of the contacts	(M $\Omega$ )	2.7

Technical data

Intro

A

B

C

D

E

F

G

H

I

J/X



New

### Mechanical latch blocks

Rated insulation voltage Ui	(V)	1000
Standard voltages Us: 50 to 60Hz and DC	(V)	24-660 & 24-440
Operating limits		85% to 110%
Consumption for unlatching (auto cut-out)		
24 to 72V		30W / 25VA
110 to 440V		15W / 12VA
<b>Electrical unlatching control</b>		18
Minimum impulse	(ms)	15 - 25
Maintained		Auto cut by internal contact
Manual unlatching control		By manual push-button
<b>Electrical making control</b>		
Minimum pulse	(ms)	40 (auto cut)
Manual making control		By manual push-button
Auxiliary contact NC		
<b>AC-15 utilisation</b> according to IEC	(V-A)	110/120-6 220/230-6 380/400-4 415/450-3.5 500-2.5 690/660-1.5
according to UL/CSA		A600
<b>DC-13 utilisation</b> according to IEC	(V-A)	24-4 48-2 110-0.7 220-0.3 440-0.15
according to UL/CSA		Q600
Mechanical endurance	10 <sup>6</sup> ops.	0.2

#### Wiring diagrams

Alternating current	
Alternating current / Direct current	

### Terminal capacity

Terminal capacity		Screw plate ECMLSA, ECMLSD
Flexible wire	(mm <sup>2</sup> )	2x0.5...2.5
AWG wire	(mm <sup>2</sup> )	2x20...14
Standard gauge		A3
Tightening torque	(Nm/Lb-in)	1.1 / 10

- Global contactors
- Intro
- A
- B
- C
- D
- E
- F
- G
- H
- I
- J/X

## Thermal mechanical overload relays for contactors from 0.16 to 40A

- Control circuit up to 690VAC
- Power circuit ECRT1, ECRT2: up to 690V
- Thermal protection against balanced overload.
- Three-pole differential (phase unbalance protection).
- Automatic ambient temperature compensation.
- Front mounted selector for choosing utilization current.
- Manual trip lever (tripping test).
- Tripping indicator (0-1).
- IP20 protection
- Reset button, 4 positions:
  - Manual RESET
  - Manual RESET and STOP
  - Automatic RESET with STOP
  - Automatic RESET without STOP

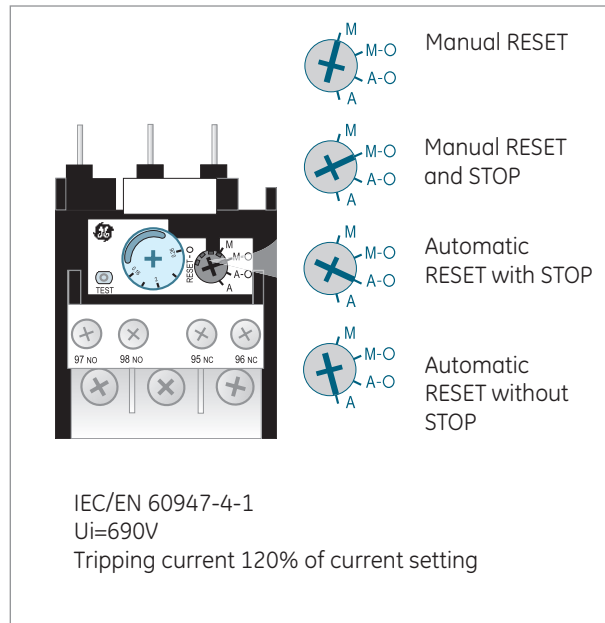

## Standards

- IEC 7 EN 60947-4-1
- IEC EN 60947-5-1
- GB14048.4
- UL508
- CSA22.2/14
- VDE 0660

## Approvals/Marking

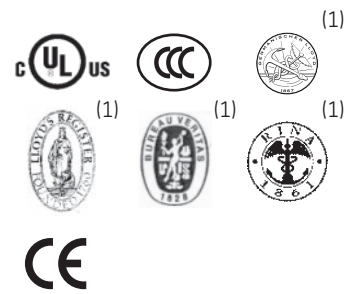

(1) In progress

## Tripping curves

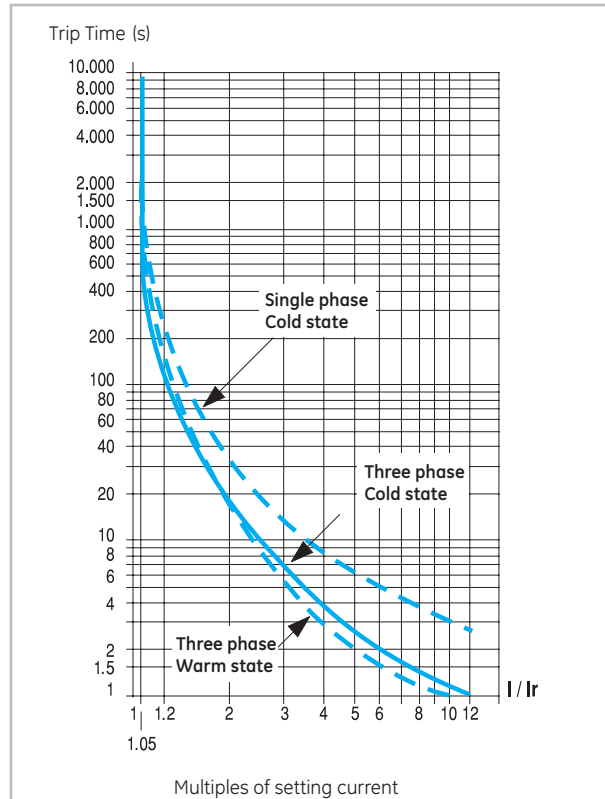

Technical data

Intro

A

B

C

D

E

F

G

H

I

J/X



New

A.21

### Thermal mechanical overload relays

Class		10A
Setting range	(A)	0.16..40
Suitable for		All Efficor contactors
<b>Main circuit</b>		
Rated insulation voltage	(V)	690
Frequency limits	(Hz)	0-400
<b>Control circuit</b>		
Rated insulation voltage (IEC60947-4) Ui	(V)	690
Rated thermal current Ith	(A)	10
<b>Operation current</b>		
AC-15 - rated voltage and current Ue-Ie	(V-A)	110/120-3 220/230-2 380/400-1 480/500-0.8 690/660-0.3
DC-13 - rated voltage and current Ue-Ie	(V-A)	24-2 48-1.4 110-0.6 220-0.3 440-0.1
Utilisation according UL and CSA		B600-Q600
Protective fuse type gL	(A)	10
Terminal capacity	(mm <sup>2</sup> )	0.75..10
Tightening capacity	(Nm)	2.2 / 20

### Terminal capacity

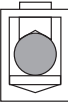
Clamp terminal - Flexible	(mm <sup>2</sup> )		0.75..10
			18..8
Clamp terminal - Standard gauge			B6
			2.2 / 20

### Ambient conditions

Storage temperature	-55°C to +80°C
Operation temperature (compensated)	-25°C to +60°C
Altitude <2000 m	without any changes in characteristics
Relative humidity	40°C, 95% no cond.
Protection treatment	Salt spary test

### Remote electrical reset

Power consumption	
AC	100VA
DC	100W

Coils not suitable for continuous operating duty

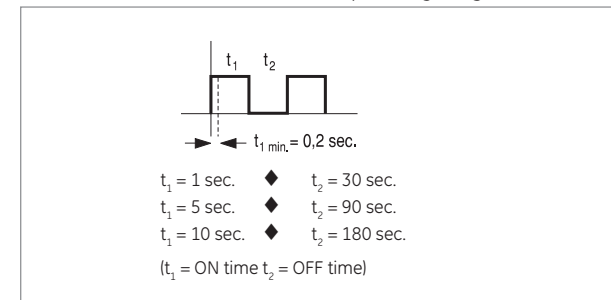

### Mounting positions

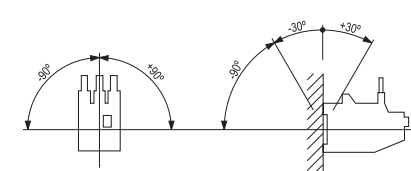

Inclination angle axis Y and Z:  $\pm 30^\circ$

Global contactors

Intro

A

B

C

D

E

F

G

H

I

J/X



New

Coordination table Type 2 with 50kA at 415V and 500V

Thermal Overload Relay	Current setting range (Aac)	415VAC												500VAC							
		Rated Power (kW)	Rated Current (A)	I <sub>n</sub> Current (kA)	I <sub>q</sub> Current (kA)	SCPDP				With MCCB as SCPDP				Rated Power (kW)	Rated Current (A)	I <sub>n</sub> Current (kA)	I <sub>q</sub> Current (kA)	With Fuse MMS as SCPDP			
						SCPDP		Contactor		SCPDP (MCCB)		Contactor						SCPDP		Contactor	
						Type	Rat. (Aac)	Type	Rat. (Aac)	Type	Rat. (Aac)	Type	Rat. (Aac)					Type	Rat. (Aac)	Type	Rat. (Aac)
ECRT1B10B	0.16 - 0.26	0.06	0.21	1	80	MMS	0.26	EC09A3	9	-	-	-	-	0.06	0.17	1	50	MMS	0.26	EC09A3	9
ECRT1B10C	0.25 - 0.41	0.09	0.31	1	80	Fuse	2	EC09A3	9	-	-	-	-	0.12	0.33	1	50	Fuse	2	EC09A3	9
ECRT1B10D	0.4 - 0.65	0.12	0.4	1	80	Fuse	4	EC09A3	9	-	-	-	-	0.18	0.48	1	50	Fuse	4	EC09A3	9
ECRT1B10F	0.65 - 1.1	0.25	0.8	1	80	Fuse	4	EC09A3	9	-	-	-	-	0.25	0.66	1	50	Fuse	4	EC09A3	9
ECRT1B10G	1.0 - 1.5	0.37	1.1	1	80	Fuse	6	EC09A3	9	-	-	-	-	0.55	1.2	1	50	Fuse	6	EC09A3	9
ECRT1B10H	1.3 - 1.9	0.55	1.5	1	80	Fuse	6	EC09A3	9	-	-	-	-	0.75	1.5	1	50	Fuse	6	EC09A3	9
ECRT1B10J	1.8 - 2.7	0.75	1.9	1	80	Fuse	6	EC09A3	9	-	-	-	-	1.1	2.1	1	50	Fuse	6	EC09A3	9
ECRT1B10K	2.5 - 4.0	1.5	3.4	1	80	Fuse	10	EC09A3	9	-	-	-	-	1.5	2.6	1	50	Fuse	10	EC09A3	9
ECRT1B10L	4.0 - 6.3	2.2	4.5	1	80	Fuse	16	EC09A3	9	-	-	-	-	3	5.3	1	50	Fuse	16	EC09A3	9
ECRT1B10M	5.5 - 8.5	3	6.5	1	80	Fuse	20	EC09A3	9	-	-	-	-	3.7	6	1	50	Fuse	20	EC09A3	9
ECRT1B10N/ ECRT2B10N	8.0 - 12	4	8	1	80	Fuse	25	EC09A3	9	MCCB	12.5	EC25A3	25	5.5	9	1	50	Fuse	25	EC09A3	9
ECRT1B10P/ ECRT2B10P	10.0 - 16.0	5.5	11	1	80	Fuse	35	EC012A3	12	MCCB	12.5	EC25A3	25	7.5	12	1	50	Fuse	35	EC12A3	12
ECRT1B10S/ ECRT2B10S	14.5 - 18.0	7.5	14.8	1	80	Fuse	40	EC018A3	18	MCCB	20	EC25A3	32	10	15.5	1	50	Fuse	40	EC18A3	18
ECRT1B10T/ ECRT2B10T	17.5 - 22	-	-	-	-	-	-	-	-	-	-	-	-	11	18.4	3	50	Fuse	40	EC18A3	18
ECRT2B10U	21.0 - 26	11	21	3	80	Fuse	50	EC025A3	25	MCCB	30	EC25A3	32	15	23	3	50	Fuse	50	EC25A3	25
ECRT2B10V	25.0 - 32.0	15	28	3	80	Fuse	63	EC032A3	32	MCCB	30	EC32A3	32	17.5	26.5	3	50	Fuse	63	EC32A3	32
ECRT2B10W	30.0 - 40	18.5	35	3	80	Fuse	80	EC040A3	40	MCCB	50	EC40A3	40	22	33	3	50	Fuse	80	EC40A3	40

Thermal overload relays, Trip Class: 10A  
 Rated operational voltage: 415Vac, 500Vac  
 Rated insulation voltage: 690Vac  
 Rated frequency: 50Hz  
 Rated duty: Eight hour duty  
 Pollution degree: 3  
 Rated conditional short-circuit protection device current: 80kA at 415Vac; 50kA at 500Vac

Technical data

Intro

A

B

C

D

E

F

G

H

I

J/X

Surion GPS high breaking capacity (Thermal Magnetic). Coordination Type 2 - 65kA at 380/400 & 415V

Motor <sup>(1)</sup>			Manual Motor Starter				Contactor	Box clamp	Minimum frontal electrical safety clearance	Links
Rated Power	Rated current (A)		Cat.No.	Rated current (In)	Thermal current	Magnetic current	Series	Smallest wire Cu (pvc) <sup>(2)</sup>		Cat.No.
kW	380/400V	415V		(A)	Setting range (A)	(A)		380/415V (mm <sup>2</sup> )	(mm)	
0.06	0.23	0.21	GPS1BHAB	0.25	0.16-0.25	3.2	EC9A..	0.75	20	ECM1AL25
0.09	0.34	0.31	GPS1BHAC	0.4	0.25-0.4	5.2	EC9A..	0.75	20	ECM1AL25
0.12	0.44	0.4	GPS1BHAD	0.63	0.4-0.63	8.2	EC9A..	0.75	20	ECM1AL25
0.18	0.65	0.63	GPS1BHAE	1	0.63-1	13	EC9A..	0.75	20	ECM1AL25
0.25	0.9	0.8	GPS1BHAE	1	0.63-1	13	EC9A..	0.75	20	ECM1AL25
0.37	1.25	1.1	GPS1BHAF	1.6	1-1.6	20.5	EC9A..	0.75	20	ECM1AL25
0.55	1.6	1.5	GPS1BHAF	1.6	1-1.6	20.5	EC9A..	0.75	20	ECM1AL25
0.75	2	1.9	GPS1BHAG	2.5	1.6-2.5	32.5	EC9A..	0.75	20	ECM1AL25
1.1	2.6	2.5	GPS1BHAH	4	2.5-4	52	EC9A..	0.75	20	ECM1AL25
1.5	3.5	3.4	GPS1BHAH	4	2.5-4	52	EC9A..	0.75	20	ECM1AL25
2.2	5	4.5	GPS1BHAJ	6.3	4-6.3	82	EC9A..	0.75	20	ECM1AL25
3	7	6.5	GPS1BHAK	10	6.3-10	130	EC9A..	1.5	20	ECM1AL25
4	9	8	GPS1BHAK	10	6.3-10	130	EC9A..	1.5	20	ECM1AL25
5.5	12	11	GPS1BHAL	13	9-13	169	EC12A..	2.3	20	ECM1AL25
7.5	16	14	GPS1BHAM	16	11.0-16	208	EC18A..	4	20	ECM1AL25
11	22.5	21	GPS1BHAP	25	19-25	325	EC25A..	6	20	ECM1AL25
15	30	28	GPS1BHAR	32	24-32	416	EC32A..	6	20	ECM1AL32
18.5	37	35	GPS2BHAS	40	28-40	520	EC40A..	10	20	ECM1AL32

(1) Current are relevant to four pole motors not having special characteristics of torque. Inrush currents: ≤ 8 time rated current for ≤ 1s.  
 (2) The minimum cycle cross-sections are referred to an ambient temperature of 30°C max. in free air and are selected to withstand the maximum let-through energy and the motor rated current. Besides the user has to consider the drop voltage, the type of laying and ambient temperature.

Global contactors  
Intro  
A  
B  
C  
D  
E  
F  
G  
H  
I  
J/X

**Record Plus Coordination Type 2 at 80kA at 380/400 & 415V**

Motor <sup>(1)</sup>			MCCB				Contactor			Overload relay	Box clamp	Clearance	
Rated Power	Rated current (A)		Cat.No.	Rated current (In)	Thermal Current	Magnetic Current	Operating current	Admissible power	Setting Range	Smallest wire Cu (pvc) <sup>(2)</sup>	Min. frontal electrical safety clearance		
	380/400V	415V										(A)	Setting range (A)
4	9	8	FD63	12.5	12.5	169	EC25A..	25	11	ECRT2	8-12	1.5	20
5.5	12	11	FD63	12.5	12.5	169	EC25A..	25	11	ECRT2	10-16	1.5	20
7.5	16	14.8	FD63	20	20	210	EC32A..	32	15	ECRT2	14.5-18	4	20
11	22.5	21	FD63	30	30	300	EC32A..	32	15	ECRT3	21-26	6	20
15	30	28	FD63	30	30	450	EC32A..	32	15	ECRT3	25-35	6	20
18.5	37	35	FD63	50	50	500	EC40A..	40	18.5	ECRT3	30-40	10	20

**Record Plus Coordination Type 2 at 80kA at 500/525V**

Motor <sup>(1)</sup>			MCCB				Contactor			Overload relay	Box clamp	Clearance	
Rated Power	Rated current (A)		Cat.No.	Rated current (In)	Thermal Current	Magnetic Current	Operating current	Admissible power	Setting Range	Smallest wire Cu (pvc) <sup>(2)</sup>	Min. frontal electrical safety clearance		
	380/400V	415V										(A)	Setting range (A)
7.5	12		FD63	12.5	12.5	-	EC32A..	32	15	ECRT2	10-19	4	20
11	18.4		FD63	20	20	-	EC32A..	32	18.5	ECRT3	17.5-25	6	20
15	23		FD63	30	30	-	EC40A..	40	18.5	ECRT3	21-29	6	20
18.5	29		FD63	30	30	-	EC40A..	40	18.5	ECRT3	25-35	10	20

(1) Current are relevant to four pole motors not having special characteristics of torque. Inrush currents: ≤ 8 time rated current for ≤ 1s.

(2) The minimum cycle cross-sections are referred to an ambient temperature of 30°C max. in free air and are selected to withstand the maximum let-through energy and the motor rated current. Besides the user has to consider the drop voltage, the type of laying and ambient temperature.

Technical data

Intro

A

B

C

D

E

F

G

H

I

J/X



New

**Contact sequence**

Device	Rating	Basic contactor	Built-in auxiliary		Auxiliary contact blocks - Front mounted-4P		
			NO	NC	40	.04	22
3P contactors 3NO	EC09	0 3.5 5	0 3.5 5	0 2 5			
	EC12						
	EC18				0 3 5	0 1.3 5	0 1.3 5
EC25	0 4 6	0 3.5 6	0 1.7 6				
				0 3 6	0 1.3 6	0 1.3 6	
EC32 EC40	0 4 6						
				0 3 6	0 1.2 6	0 1.2 6	
4P contactors 4NO	EC12						
	EC18						
4P contactors 2NO+2NC	EC09	0 3.3 5			0 3.3 5		0 3.3 5
	EC12						
EC25 EC32 EC40	0 4 6			0 4 6			
				0 2 6	0 2 6	0 2 6	

**Contact sequence (auxiliary contactors)**

4P contactors 4NO	ECAC09	0 3.3 5			0 3.3 5		0 3.3 5
	ECAC12						
	ECAC18						
	ECAC25				0 1.7 5	0 1.7 5	0 1.7 5
4P contactors 2NO+2NC	ECAC09	0 3.3 5			0 3.3 5		0 3.3 5
	ECAC12						
	ECAC18						
	ECAC25	0 1.7 5			0 1.7 5	0 1.7 5	0 1.7 5

- Global contactors
- Intro
- A
- B
- C
- D
- E
- F
- G
- H
- I
- J/X



New



		Auxiliary contact blocks - Front mounted-2P				Auxiliary contact blocks - Front mounted-2P			
		31	13	11	02	20	02	20	11
		0 3 5  0 1.3 5	0 3 5  0 1.3 5	0 3.4 5  0 1.3 5	0 1.3 5  0 1.3 5	0 3.4 5  0 1.5 5	0 3.7 5  0 1.5 5	0 3.7 5  0 1.5 5	0 3.7 5  0 1.5 5
		0 3 6  0 1.3 6	0 3 6  0 1.3 6	0 3.2 6  0 1.1 6	0 1.1 6  0 1.1 6	0 3.2 6  0 1.3 6	0 3.8 6  0 1.3 6	0 3.8 6  0 1.3 6	0 3.8 6  0 1.3 6
		0 3 6  0 1.2 6	0 3 6  0 1.2 6	0 3.2 6  0 1.1 6	0 1.1 6  0 1.1 6	0 3.2 6  0 1.3 6	0 3.8 6  0 1.3 6	0 3.8 6  0 1.3 6	0 3.8 6  0 1.3 6
		0 1.5 6  0 1.5 6	0 1.5 6  0 1.5 6	0 3.5 6  0 1.5 6	0 1.5 6  0 1.5 6	0 3.5 6  0 1.5 6	0 1.5 6  0 1.5 6	0 3.5 6  0 1.5 6	0 3.5 6  0 1.5 6
		0 3.3 5  0 1.7 5	0 3.3 5  0 1.7 5	0 3.3 5  0 1.7 5	0 1.7 5  0 1.7 5	0 3.3 5  1.7 5	0 1.7 5  1.7 5	0 3.3 5  0 1.7 5	0 3.3 5  0 1.7 5
		0 4 6  0 2 6	0 4 6  0 2 6	0 4 6  0 2 6	0 2 6  0 2 6	0 4 6  0 2 6	0 4 6  0 2 6	0 4 6  0 2 6	0 4 6  0 2 6
		0 3.3 5  0 1.7 5	0 3.3 5  0 1.7 5	0 3.3 5  0 1.7 5	0 1.7 5  0 1.7 5	0 3.3 5  0 1.7 5	0 1.7 5  0 1.7 5	0 3.3 5  0 1.7 5	0 3.3 5  0 1.7 5
		0 3.3 5  0 1.7 5	0 3.3 5  0 1.7 5	0 3.3 5  0 1.7 5	0 1.7 5  0 1.7 5	0 3.3 5  0 1.7 5	0 1.7 5  0 1.7 5	0 3.3 5  0 1.7 5	0 3.3 5  0 1.7 5

Technical data

Intro

A

B

C

D

E

F

G

H

I

J/X



New

## Terminal numbering

### 3P and 4P contactors

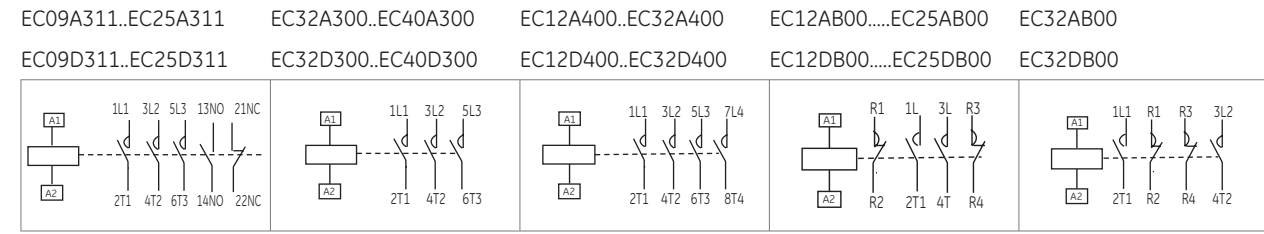

### Auxiliary contactors

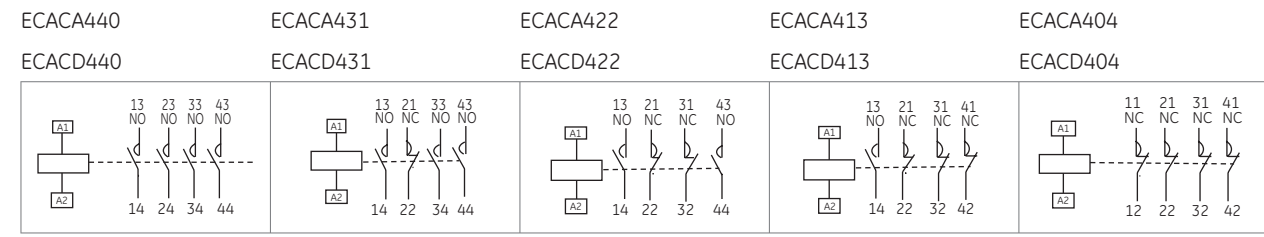

### Auxiliary contact blocks - Front mounting

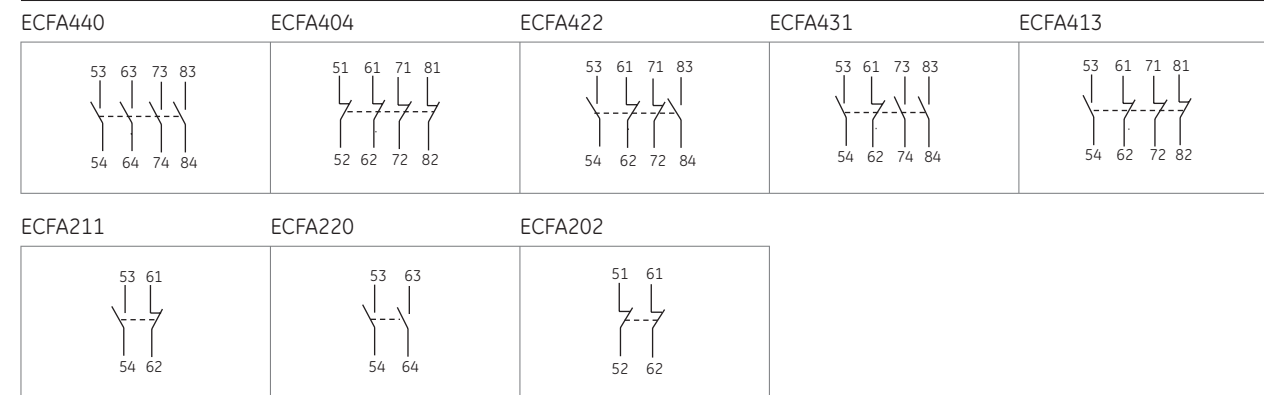

### Auxiliary contact blocks - Lateral mounting

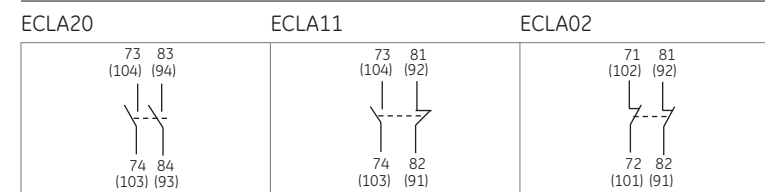

### Mechanical and mechanical/electrical interlock

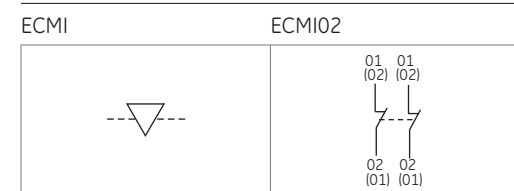

**Terminal numbering (continued)**

*Pneumatic timer blocks*

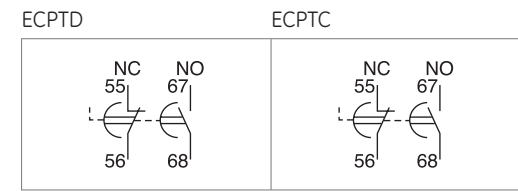

*Voltage suppressor blocks*

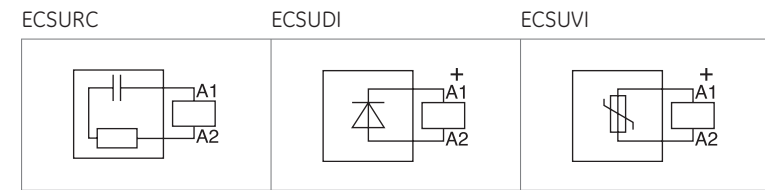

*Mechanical latch block*

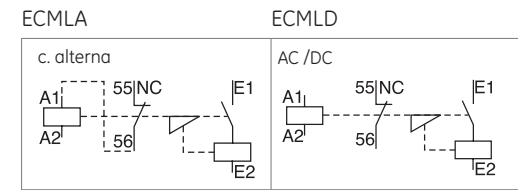

Technical data

Intro

A

B

C

D

E

F

G

H









I

J/X

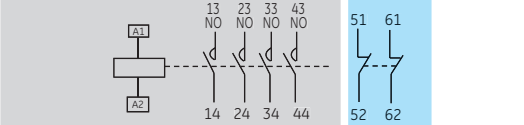

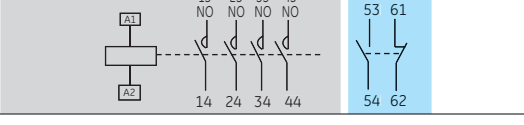
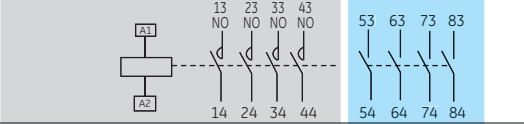
New

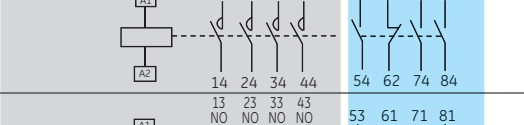
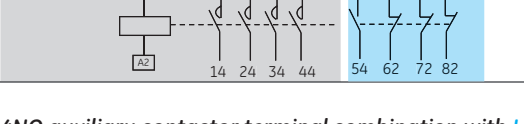
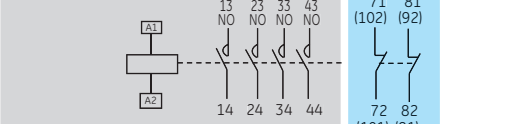
Terminal numbering according to EN 50011

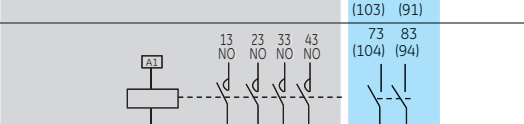
Auxiliary contacts	Description			Possible basic auxiliary contactors + Auxiliary contacts blocks to be added
<b>4NO auxiliary contactor terminal combination with 2P FRONTAL block</b>				
	42E	4	2	ECACA440 ECACD440 +ECFA202
	60E	6	0	ECACA440 ECACD440 +ECFA220
	51E	5	1	ECACA440 ECACD440 +ECFA211
<b>4NO auxiliary contactor terminal combination with 4P FRONTAL block</b>				
	80E	8	0	ECACA440 ECACD440 +ECFA440
	44E	4	4	ECACA440 ECACD440 +ECFA440
	62E	6	2	ECACA440 ECACD440 +ECFA422
	71E	7	1	ECACA440 ECACD440 +ECFA431
	53E	5	3	ECACA440 ECACD440 +ECLFA413
<b>4NO auxiliary contactor terminal combination with LATERAL - block mounted on the RIGHT side of contactor</b>				
	42	4	2	ECACA440 ECACD440 +ECLA202
	51	5	1	ECACA440 ECACD440 +ECLA211
	60	6	0	ECACA440 ECACD440 +ECLA220

Global contactors

Intro

A

B

C

D

E

F



G

H







I

J/X

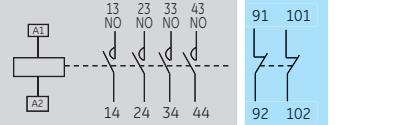
Terminal numbering according to EN 50011 (continued 1)

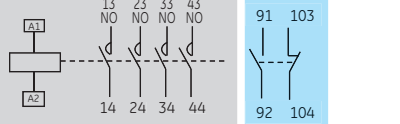
Auxiliary contacts	Description			Possible basic auxiliary contactors + Auxiliary contacts blocks to be added
--------------------	-------------	---	---	---

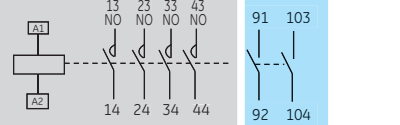







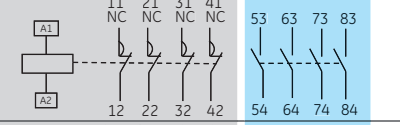

4NO auxiliary contactor terminal combination with LATERAL - block mounted on the LEFT side of contactor

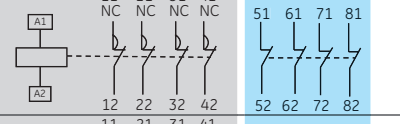
	42	4	2	ECACA440 ECACD440 +ECLA202	
	51	5	1	ECACA440 ECACD440 +ECLA211	
	6	6	0	ECACA440 ECACD440 +ECLA220	

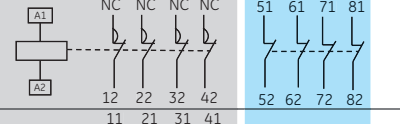
4NC auxiliary contactor terminal combination with 2P FRONTAL block

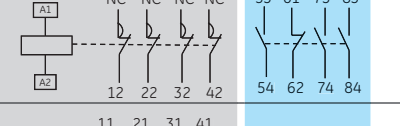
	06E	6	0	ECACA404 ECACD404 +ECFA202	
	24E	2	4	ECACA404 ECACD404 +ECFA220	
	15E	5	1	ECACD404 ECACA404 +ECFA211	

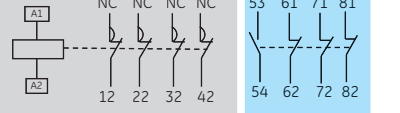
4NC auxiliary contactor terminal combination with 4P FRONTAL block

	44E	4	4	ECACA404 ECACD404 +ECFA440	
	08E	0	8	ECACA404 ECACD404 +ECFA404	
	26E	2	6	ECACA404 ECACD404 +ECFA422	
	35E	3	5	ECACA404 ECACD404 +ECFA431	
	17E	1	7	ECACA404 ECACD404 +ECLA413	

Technical data

Intro

A

B

C

D

E

F

G

H



I

J/X









New

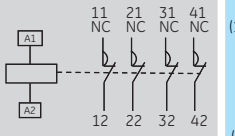

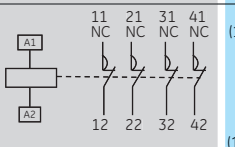

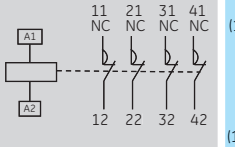

Terminal numbering according to EN 50011 (continued 2)

Auxiliary contacts	Description			Possible basic auxiliary contactors + Auxiliary contacts blocks to be added
--------------------	-------------	---	---	---

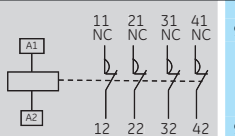
4NC auxiliary contactor terminal combination with LATERAL - block mounted on the RIGHT side of contactor

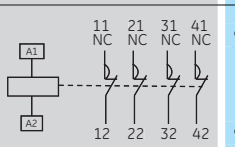
	42	0	6	ECACA404 ECACD404 +ECLA202	
	15	1	5	ECACA404 ECACD404 +ECLA211	
	24	2	4	ECACA404 ECACD404 +ECLA220	

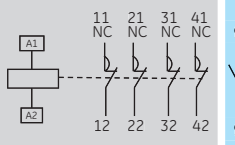
4NC auxiliary contactor terminal combination with LATERAL - block mounted on the LEFT side of contactor

	42	4	2	ECACA440 ECACD440 +ECLA202	
	51	5	1	ECACA440 ECACD440 +ECLA211	
	6	6	0	ECACA440 ECACD440 +ECLA220	

Global contactors

Intro

A

B

C

D

E

F



G

H

I

J/X







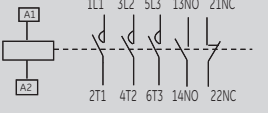
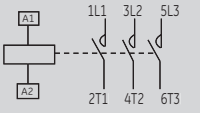



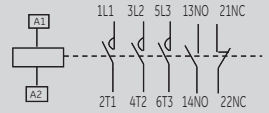

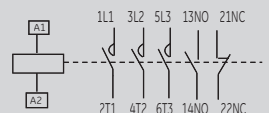
Terminal numbering according to EN 50012

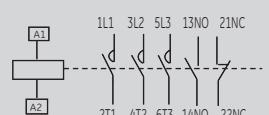
Auxiliary contacts	Description			Possible basic auxiliary contactors + Auxiliary contacts blocks to be added
--------------------	-------------	---	---	---

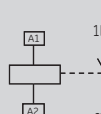
Terminal numbering according to EN 50012

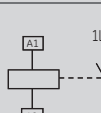
	11E	1	1	EC09A311..EC25A311 EC09D311..EC25D311
	-	0	0	EC32A300..EC40A300 EC32D300..EC40D300

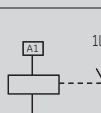
FRONT mounted auxiliary contact blocks with 2 contacts each

	13	1	3	EC09A311..EC25A311 EC09D311..EC25D311 +ECFA202	
	31	3	1	EC09A311..EC25A311 EC09D311..EC25D311 +ECFA220	
	22	2	2	EC09A311..EC25A311 EC09D311..EC25D311 +ECFA211	
	02	0	2	EC32A300..EC40A300 EC32D300..EC40D300 +ECFA202	
	20	2	0	EC32A300..EC40A300 EC32D300..EC40D300 +ECFA220	
	11	1	1	EC32A300..EC40A300 EC32D300..EC40D300 +ECFA211	

LATERAL mounted auxiliary contact blocks with 2 contacts each - RIGHT side mounted

	13	1	3	EC09A311..EC25A311 EC09D311..EC25D311 +ECLA220	
	22	2	2	EC09A311..EC25A311 EC09D311..EC25D311 +ECLA211	

Technical data

Intro

A

B

C

D

E

F

G

H



I

J/X









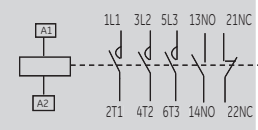

New

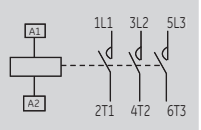

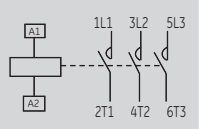

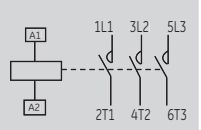





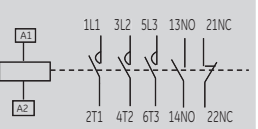

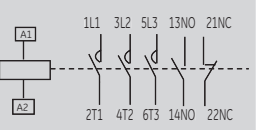
Terminal numbering according to EN 50012 (continued 1)

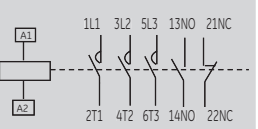
Auxiliary contacts	Description			Possible basic auxiliary contactors + Auxiliary contacts blocks to be added
--------------------	-------------	---	---	---

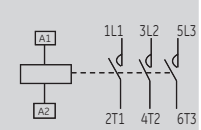
LATERAL mounted auxiliary contact blocks with 2 contacts each - RIGHT side mounted (continued)

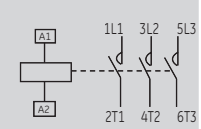
	31	3	1	EC09A311..EC25A311 EC09D311..EC25D311 +ECLA220	
	02	0	2	EC32A300..EC40A300 EC32D300..EC40D300 +ECLA202	
	11	1	1	EC32A300..EC40A300 EC32D300..EC40D300 +ECLA211	
	20	2	0	EC32A300..EC40A300 EC32D300..EC40D300 +ECLA220	

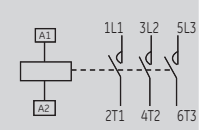
LATERAL mounted auxiliary contact blocks with 2 contacts each - LEFT side mounted

	13	1	3	EC09A311..EC25A311 EC09D311..EC25D311 +ECLA202	
	22	2	2	EC09D311..EC25D311 EC09A311..EC25A311 +ECLA211	
	31	3	1	EC09A311..EC25A311 EC09D311..EC25D311 +ECLA220	
	02	0	2	EC32A300..EC40A300 EC32D300..EC40D300 +ECLA202	
	11	1	1	EC32A300..EC40A300 EC32D300..EC40D300 +ECLA211	
	20	2	0	EC32A300..EC40A300 EC32D300..EC40D300 +ECLA220	

Global contactors

Intro

A

B

C

D

E

F

G

H

I

J/X



New



Terminal numbering according to EN 50012 (continued 2)

Auxiliary contacts	Description	NO	NC	Possible basic auxiliary contactors + Auxiliary contacts blocks to be added
--------------------	-------------	----	----	---

FRONT mounted auxiliary contact blocks with 4 contacts each

	51	5	1	EC09A311..EC25A311 EC09D311..EC25D311 +ECFA440
	15	1	5	EC09A311..EC25A311 EC09D311..EC25D311 +ECFA404
	33	3	3	EC09A311..EC25A311 EC09D311..EC25D311 +ECFA422
	42	4	2	EC09A311..EC25A311 EC09D311..EC25D311 +ECFA431
	24	2	4	EC09A311..EC25A311 EC09D311..EC25D311 +ECFA413
	40	4	0	EC09A311..EC25A311 EC09D311..EC25D311 +ECFA440
	04	0	4	EC09A311..EC25A311 EC09D311..EC25D311 +ECFA404
	22	2	2	EC32A300..EC40A300 EC32D300..EC40D300 +ECFA422
	31	3	1	EC32A300..EC40A300 EC32D300..EC40D300 +ECFA431
	13	1	3	EC32A300..EC40A300 EC32D300..EC40D300 +ECFA413

Technical data

Intro

A

B

C

D

E

F

G

H

I

J/X



New

Dimensions and weights

Contactors

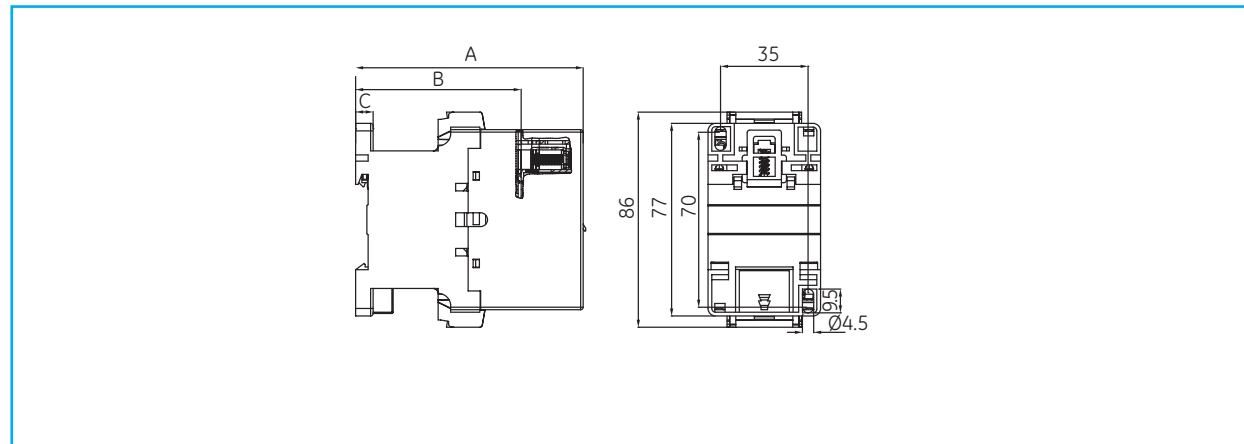

Dimensions in mm	EC09A3 - EC18A3	EC25A3	EC32A3 - EC40A3	EC09D3 - EC18D3	EC25D3	EC32D3 - EC40D3
A	92	97	102	102	110	115
B	66.2	66.2	67.2	76.2	80.2	81.2
C	7	7	7	7	7	7
Weight in g	350	490	530	620	700	740

Thermal overload relay ECRT1

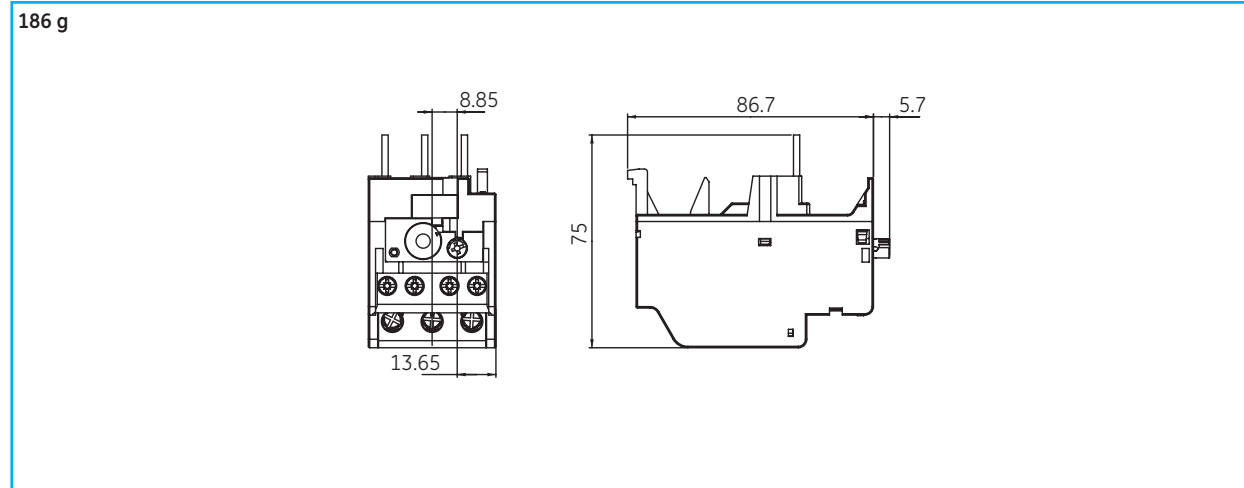

Thermal overload relay ECRT2

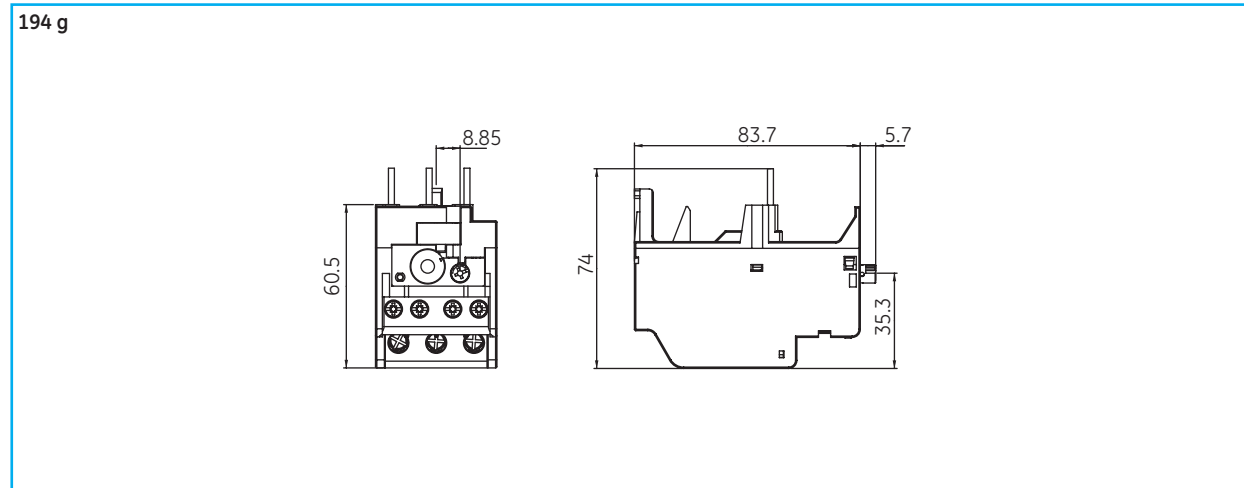

Global contactors

Intro

A

B

C

D

E

F

G

H

I

J/X

Combination of contactor EC09A-12A-18A and thermal overload relay ECRT1

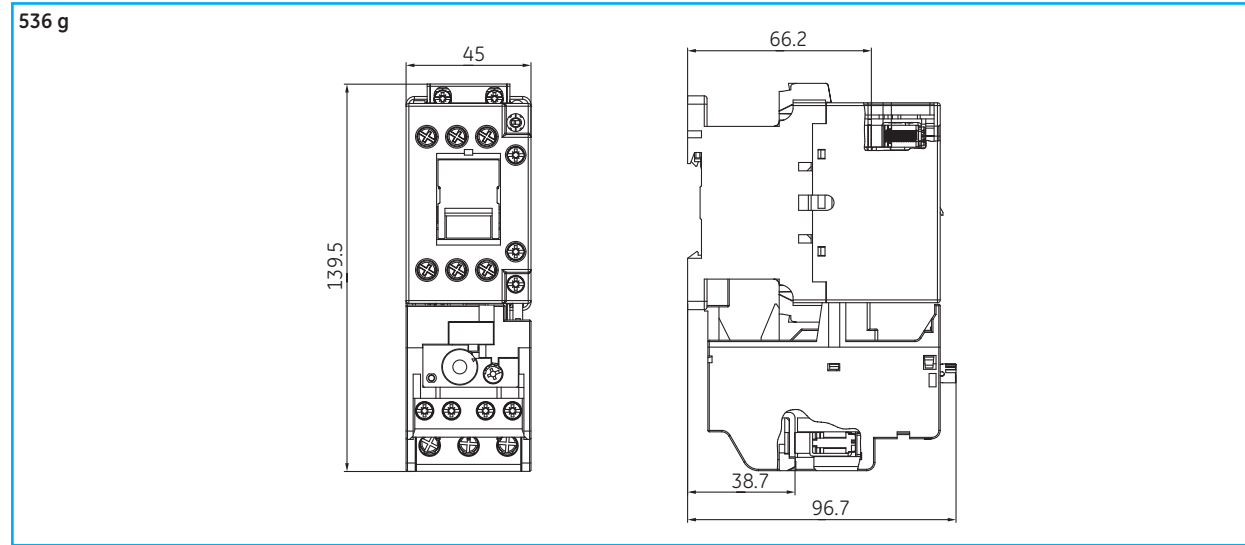

Combination of contactor EC25A and thermal overload relay ECRT2

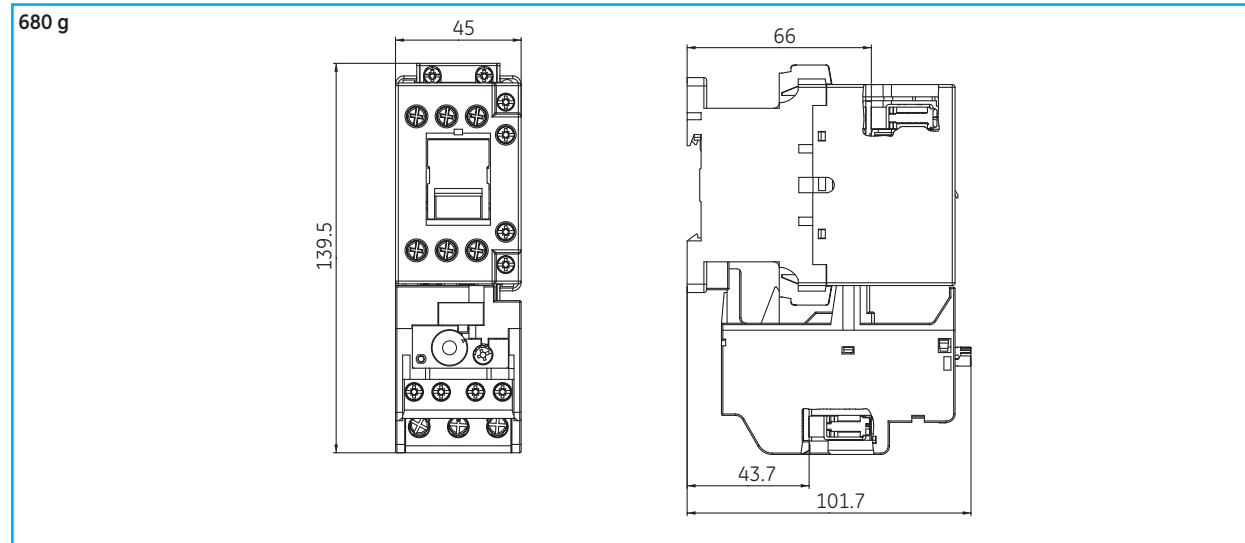

Combination of contactor EC32A-40A and thermal overload relay ECRT2

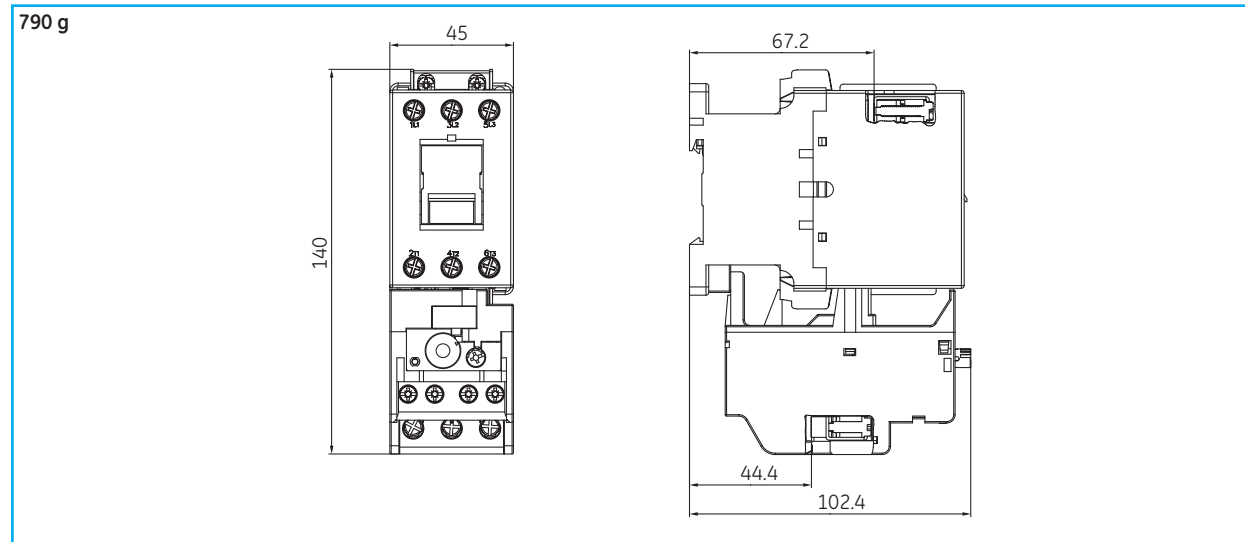

Technical data

Intro

A

B

C

D

E

F

G

H

I

J/X



New

Dimensions and weights

Auxiliary contactors ECACA

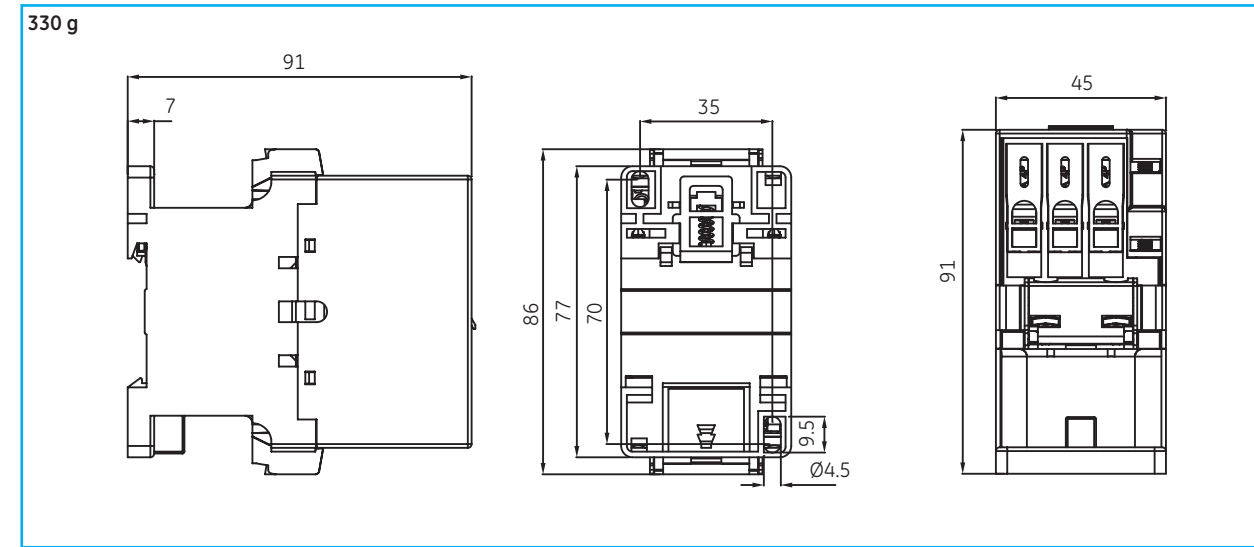

Frontal auxiliary contact block 2P ECFA2S

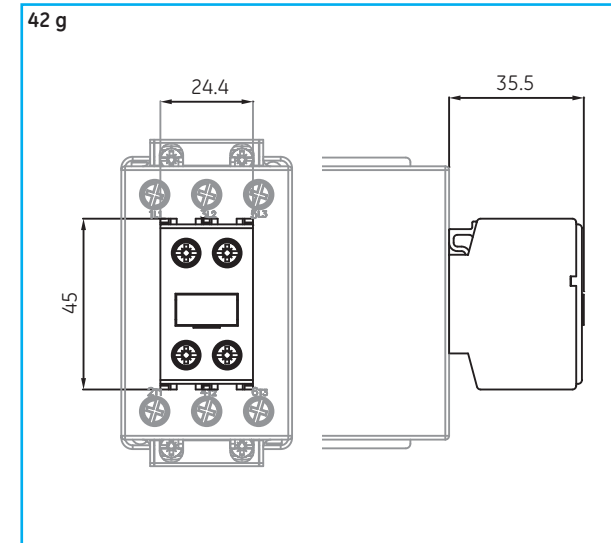

Frontal auxiliary contact block 4P ECFA4S

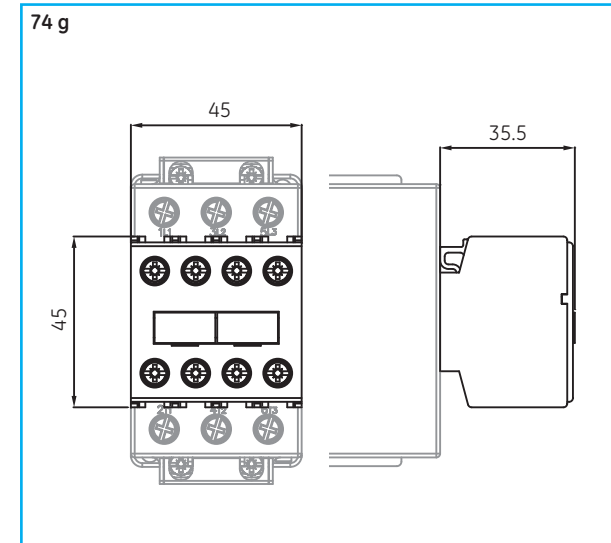

Lateral auxiliary contact block ECLA

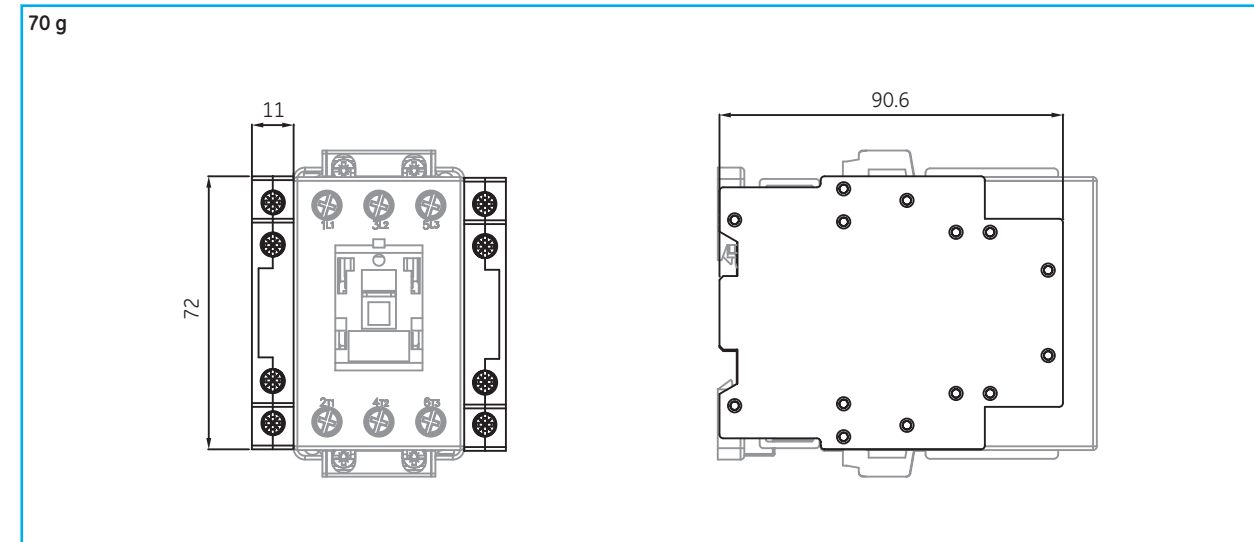

Global contactors  
Intro  
A  
B  
C  
D  
E  
F  
G  
H  
I  
J/X

**Lateral auxiliary mechanical interlock ECMI**

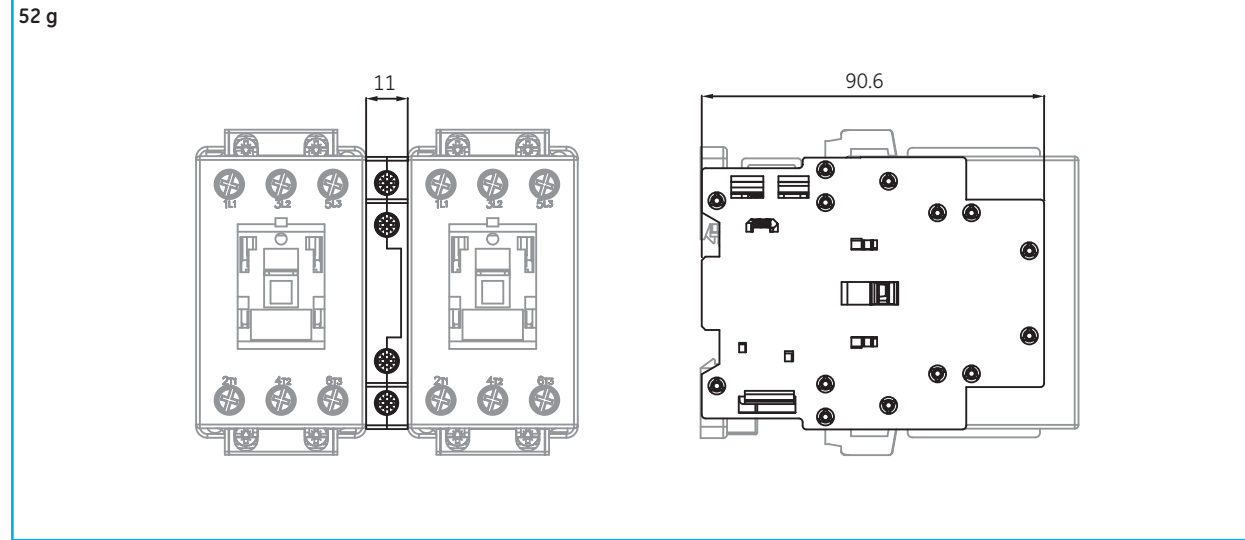

**Pneumatic timer ECPT**

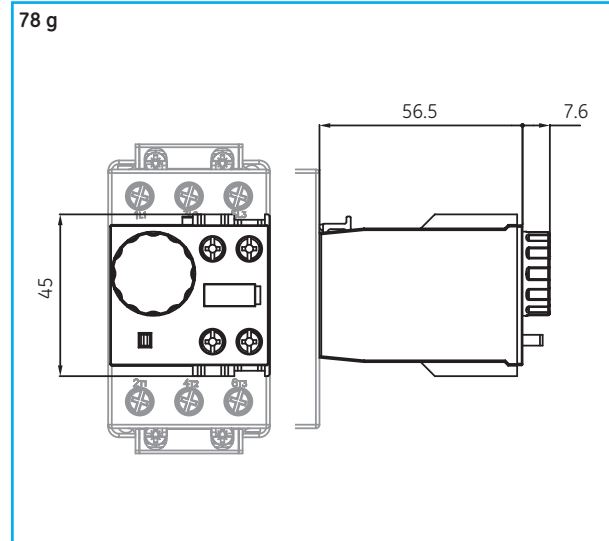

**Mechanical latch ECML**

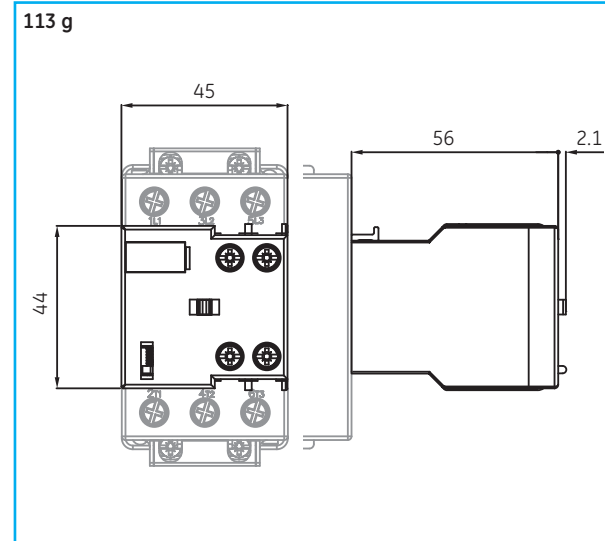

Technical data

Intro

A

B

C

D

E

F

G

H

I

J/X



New

**Dimensions and weights**

**Starter combination of manual motor starter Surion GPS1 and contactor EC09A-12A-18A**

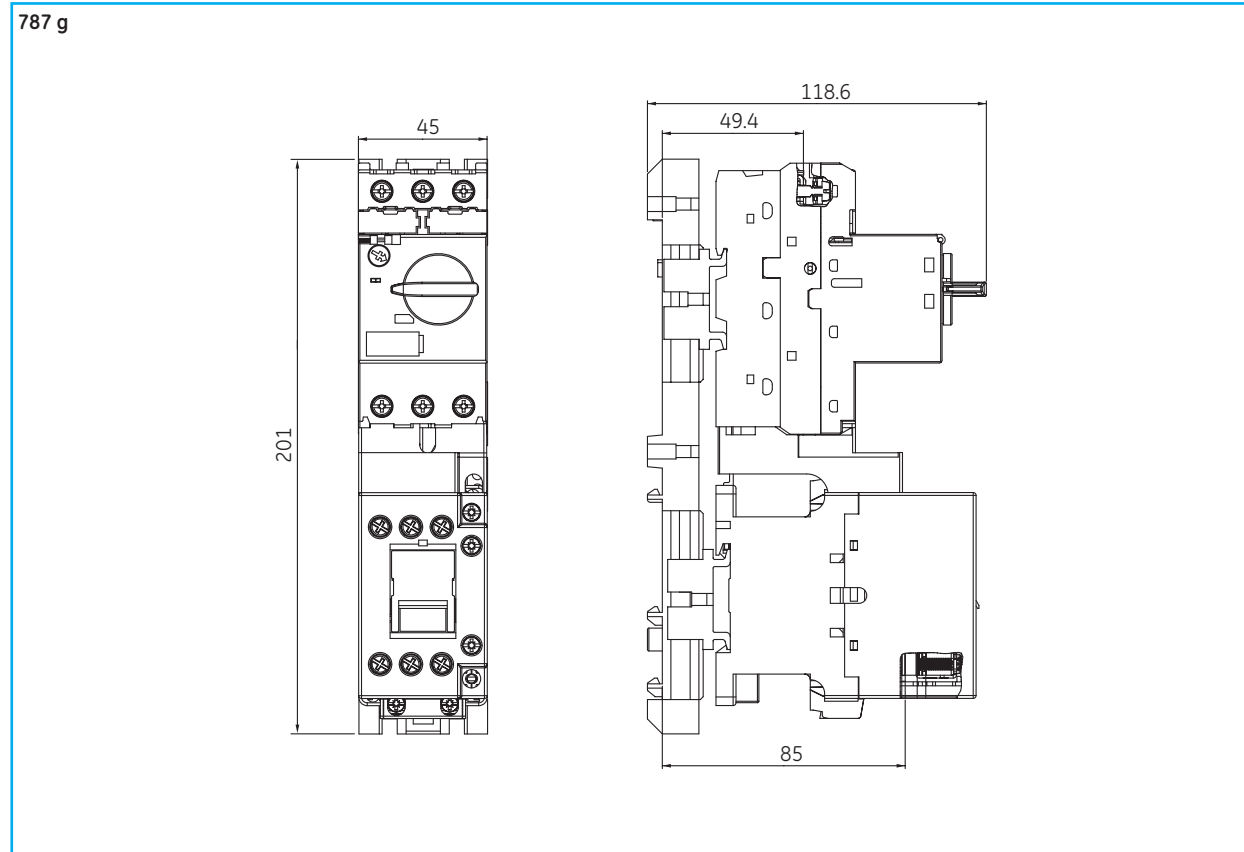

**Starter combination of manual motor starter Surion GPS1 and contactor EC25A**

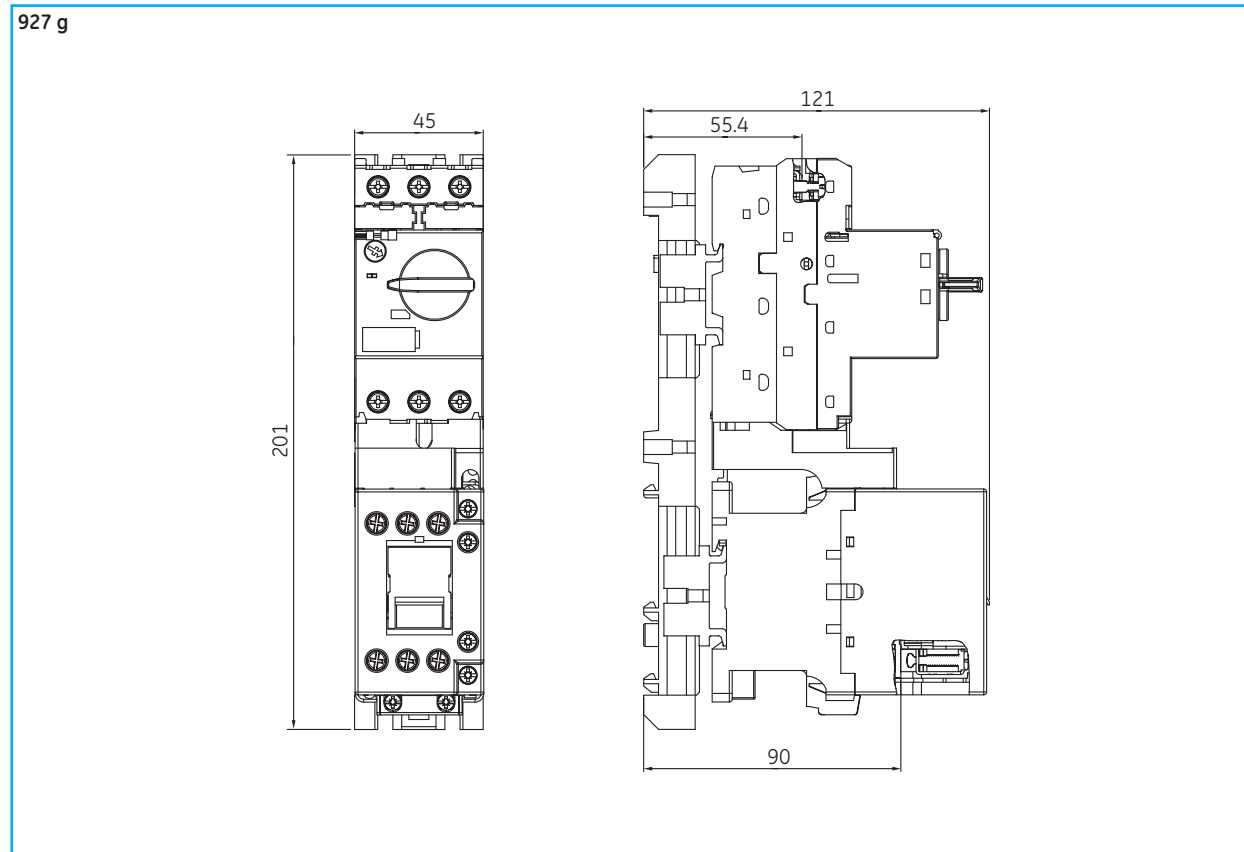

- Global contactors
- Intro
- A
- B
- C
- D
- E
- F
- G
- H
- I
- J/X

Starter combination of manual motor starter Surion GPS1 and contactor EC32A

967 g

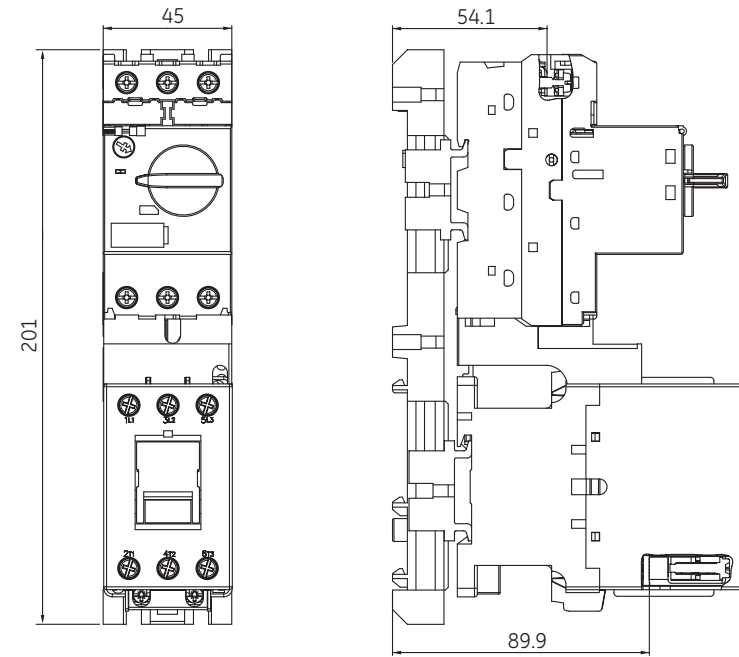

Starter combination of manual motor starter Surion GPS2 and contactor EC40A

1368 g

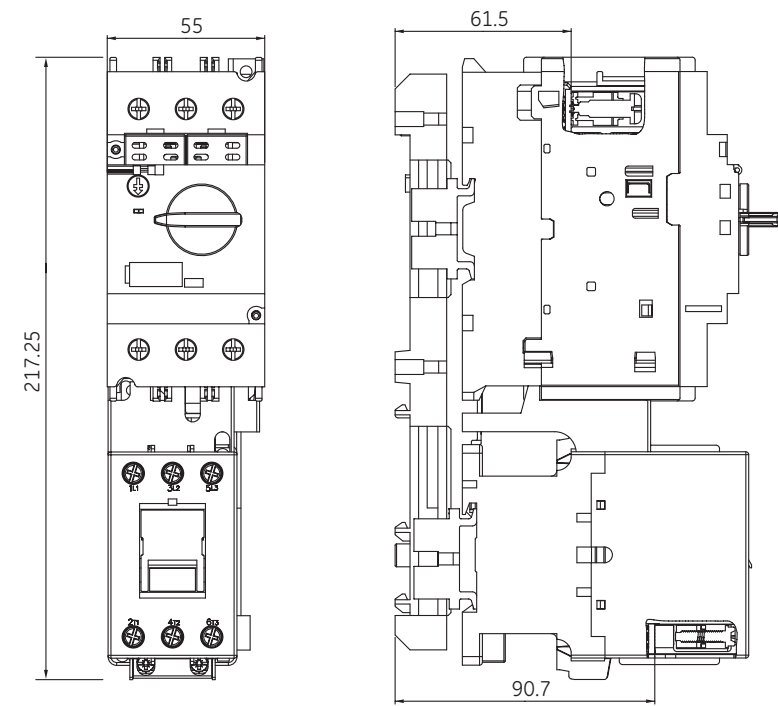

Technical data

Intro

A

B

C

D

E

F

G

H

I

J/X



New

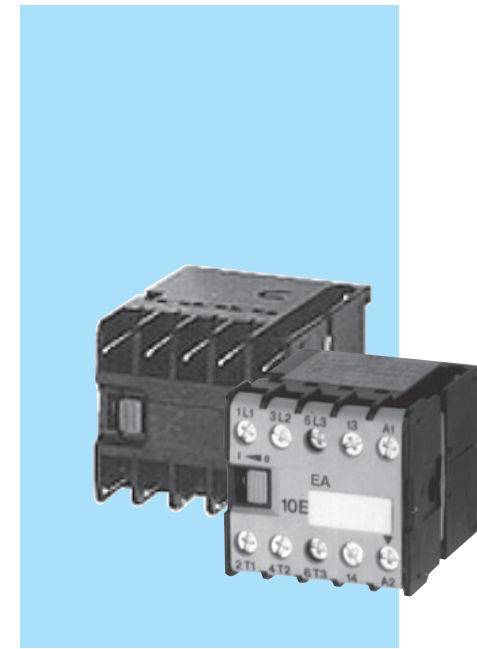

**Three pole minicontactors**  
**7A (AC3)**  
**16A (AC1)**

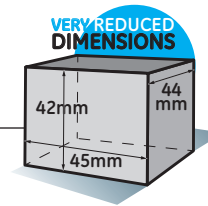

- Control circuit:
  - Alternating current up to 230VAC at 50/60Hz
  - Direct current up to 110VDC
- Low consumption:
  - Only 1.2 WDC
  - 2.4W In AC
- Power circuit: Up to 400VAC
- Rating:
  - 7.3A AC3 at 400V
  - 16A AC1
  - Ith 16A
  - AC15: - 6A 230V
  - 4A 400V
- Motor rating AC-3 duty, 3 phases
  - 230V 1.5kW
  - 400/415V 3kW
- Very reduced dimensions: 42/45/44mm (HxWxD)
- Lateral carrier
- Terminal numbering in accordance with EN 50012
- Fixing by clipping onto 35mm DIN rail (EN 50022-35) or by screws
- Terminal versions:
  - Screws as standard
  - Solder pin for circuit board application
- Integrated one auxiliary contact block: 1NO or 1NC
- No accessories
  - No available additional auxiliary contacts
  - Stand-alone thermal protection

**Standards**

IEC/EN 60947-1  
 IEC/EN 60947-4-1  
 VDE 0660  
 BS5424

**Approvals**





AC contactors



Power rating AC3 (kW)		Terminal	Poles	Auxiliary contacts		Control circuit	Voltage	Cat. no.	Ref. no.	Pack
230V	400V			NO	NC					
1.5	3	Screw	3	1	0	AC	24	EA07A310S024	247990	10
1.5	3	Screw	3	0	1	AC	24	EA07A301S024	247991	10
1.5	3	Screw	3	1	0	AC	48	EA07A310S048	247992	10
1.5	3	Screw	3	0	1	AC	48	EA07A301S048	247993	10
1.5	3	Screw	3	1	0	AC	110	EA07A310S110	247994	10
1.5	3	Screw	3	0	1	AC	110	EA07A301S110	247995	10
1.5	3	Screw	3	1	0	AC	230	EA07A310S230	247996	10
1.5	3	Screw	3	0	1	AC	230	EA07A301S230	247997	10
1.5	3	Screw	3	1	0	DC	24	EA07D310S024	247998	10
1.5	3	Screw	3	0	1	DC	24	EA07D301S024	247999	10
1.5	3	Screw	3	1	0	DC	110	EA07D310S110	248000	10
1.5	3	Screw	3	0	1	DC	110	EA07D301S110	248001	10
1.1	1.5	Solder pin	3	1	0	AC	24	EA07A310I024	248004	10
1.1	1.5	Solder pin	3	0	1	AC	24	EA07A301I024	248005	10
1.1	1.5	Solder pin	3	1	0	DC	48	EA07D310I048	248006	10
1.1	1.5	Solder pin	3	0	1	DC	48	EA07D301I048	248007	10
1.1	1.5	Solder pin	3	1	0	DC	110	EA07D310I110	248008	10
1.1	1.5	Solder pin	3	0	1	DC	110	EA07D301I110	248009	10
1.1	1.5	Solder pin	3	1	0	AC	230	EA07A310I230	248002	10
1.1	1.5	Solder pin	3	0	1	AC	230	EA07A301I230	248003	10

Order codes

Intro

A

B

C

D

E

F

G

H

I

VX



NEW in 2013

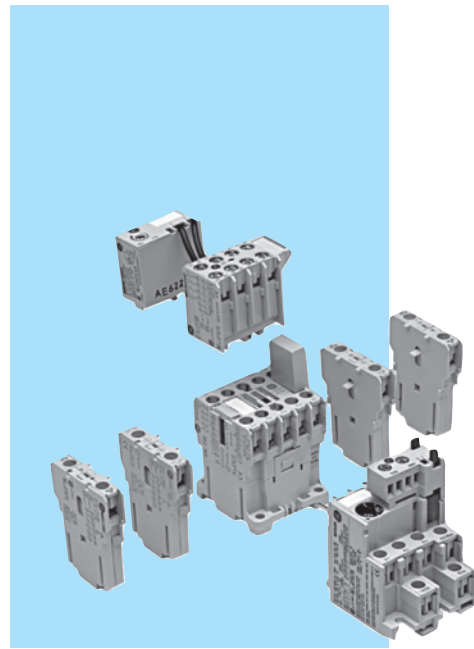

### Three and four pole contactors 9 and 12A (AC3) 20A (AC1)

- Control circuit: Alternating current up to 600V  
Direct current up to 440V
- Terminal numbering in accordance with EN 50012
- Fixing by clipping onto 35 mm DIN rail (EN 50022-35) or by screws
- Screws and fast-on terminals protected against accidental contact in accordance with VDE 0106 T.100 and VBG4
- Versions: Ring terminal and printed circuit terminals
- Facility to mount instant and timed auxiliary contact blocks and voltage suppressor block
- Degree of protection IP20 (EN 60529).
- Maximum number of auxiliary contacts to be added: 6

#### Standards

IEC/EN 60947-1	BS 4794
IEC/EN 60947-4-1	NFC 63-110
IEC/EN 60947-5-1	CSA C22.2/14
EN 50003	VDE 0660
EN 50005	SEV 10254
EN 50012	JIS C8325
UL 508	JEM 1038
NEMA ICS-1	CENELEC HD 419

#### General data

	MC1...	MC2...
Maximum number of poles	4	4
Rated thermal current (I <sub>th</sub> ) θ ≤ 60° (1)	(A) 20	20
Rated operational current I <sub>e</sub> (2) (3x440V, 50/60Hz, AC3)	(A) 9	12
Rated insulation current U <sub>i</sub>	(V) 750	750
Rated operational current U <sub>e</sub>	(V) 690	690

#### Approvals



(Contact GE for details)

- Order codes ● pg. A.45
- Auxiliary contact blocks ● pg. A.48
- Accessories ● pg. A.50
- Technical data ● pg. A.83
- Terminal numbering ● pg. A.89
- Dimensions ● pg. A.110

#### Standard voltages

To complete the catalogue number, replace the symbol ♦ by the code corresponding to the voltage and frequency of the control circuit (other voltages on request)

##### Alternating current (V). Bifrequency coil

♦	10	1	2	9	3	4	5	6	7	8	12	13
AC	12	24	42	48	110	120	220	230	240	440	380	400
50/60Hz					115							

##### Operating voltages limits with bifrequency coils:

With 60Hz = 0.85 to 1.1 x U<sub>s</sub>

With 50Hz = 0.8 to 1.1 x U<sub>s</sub> in continuous service (ED=100%) with a maximum ambient temperature of 40°C

##### Alternating current (V).

♦	A	E	G	K	M	N	S	U	W	Y
AC			48	115		220	260	380	415	500
50Hz				127		240		400	440	
AC	6	32	60		208	240		440	480	600
60Hz					220	277				

##### Direct current (V)

♦	A	B	C	D	E	F	G	H	I	J	K	L	N	17	R	S	16
DC	6	12	32	24	36	42	48	60	72	110	120	125	220	230	240	250	440

##### Direct current (V) - Wide voltage range

♦	WD	WE	WG	WI	WJ	WN
DC	24	33	48	72	110	220



Three pole contactors



Max.operat.current Non-inductive loads AC1 <sup>(2)</sup> A	Motors <440V, 3 ~ 50/60Hz AC3 <sup>(3)</sup> A	Admissible power AC3						Aux. contacts		Control circuit: Alternating current		Control circuit: Direct current					
		1-phase		3-phase				•3	•1	Cat. no. <sup>(1)</sup>	Pack	Cat. no. <sup>(1)</sup>	Pack				
		115V	220V	220V	380V	500V	230V	400V	•4	•2	Ref. no. see bottom		Ref. no. see bottom				
		kW	kW	kW	kW	kW	kW	kW									
		HP	HP	HP	HP	HP	HP	HP									
<b>Terminal: screw</b>																	
20	9	0.56	1.12	2.2	4	4	0.75	1.5	3	5.5	5.5	1	0	MC1A310AT ♦	20	MC1C310AT ♦	10
												0	1	MC1A301AT ♦	20	MC1C301AT ♦	10
20	12	0.75	2	3	5.5	5.5	1	2.6	4	7.3	7.3	1	0	MC2A310AT ♦	20	MC2C310AT ♦	10
												0	1	MC2A301AT ♦	20	MC2C301AT ♦	10
<b>Terminal: ring terminal</b>																	
20	9	0.56	1.12	2.2	4	4	0.75	1.5	3	5.5	5.5	1	0	MC1A310AR ♦	20	MC1C310AR ♦	10
												0	1	MC1A301AR ♦	20	MC1C301AR ♦	10
20	12	0.75	2	3	5.5	5.5	1	2.6	4	7.3	7.3	1	0	MC2A310AR ♦	20	MC2C310AR ♦	10
												0	1	MC2A301AR ♦	20	MC2C301AR ♦	10
<b>Terminal: faston 2x2.8 insulated <sup>(5)</sup></b>																	
16 <sup>(4)</sup>	9	0.56	1.12	2.2	4	4	0.75	1.5	3	5.5	5.5	1	0	MC1A310AF ♦	20	MC1C310AF ♦	10
												0	1	MC1A301AF ♦	20	MC1C301AF ♦	10
<b>Terminal: printed circuit</b>																	
20	9	0.56	1.12	2.2	4	4	0.75	1.5	3	5.5	5.5	1	0	MC1A310AI ♦	20	MC1C310AI ♦	10
												0	1	MC1A301AI ♦	20	MC1C301AI ♦	10
20	12	0.75	2	3	5.5	5.5	1	2.6	4	7.3	7.3	1	0	MC2A310AI ♦	20	MC2C310AI ♦	10
												0	1	MC2A301AI ♦	20	MC2C301AI ♦	10
<b>Spare coil</b>																	
														MB0A ♦	10	MB0C ♦	10

(1) To complete the catalogue number, replace the symbol ♦ by the code corresponding to the voltage and frequency of the control circuit (other voltages on request) (see A.44)  
 (2) Electrical endurance AC-1: MC1... 0.3 x 10<sup>6</sup> operations  
 MC2... 0.35 x 10<sup>6</sup> operations  
 (3) Electrical endurance AC-3: MC1... (9A) = 0.85 x 10<sup>6</sup> operations  
 MC2... (12A) = 0.6 x 10<sup>6</sup> operations  
 (4) Terminal with wire 1.5 mm<sup>2</sup>: I<sub>e</sub> = 16A  
 with wire 1 mm<sup>2</sup>: I<sub>e</sub> = 10A  
 Insulated terminal type B 2.8 x 0.8 and wire 1 mm<sup>2</sup> I<sub>e</sub> = 8A in accordance with DIN 46247.  
 (5) Fast-on 1 x 6.3 terminals on request (replace letter F by H in the catalogue number)

Order codes

Intro

A

B

C

D

E

F

G

H

I

J/X

For reference numbers, see chapter X, pg. X.2



Three pole interface contactors



Max. oper. current Non-inductive load AC1 A	Motors <440V, 3 ~ 50/60Hz AC3 <sup>(3)</sup> A	Admissible power AC3					Aux. contacts •3  •4	Voltage 24V D.C, coil 1.2W <sup>(1)</sup>			Voltage 24V D.C, coil 2W <sup>(2)</sup>			
		1-phase		3-phase				Cat. no. <sup>(1)</sup>	Ref. no.	Pack	Cat. no. <sup>(1)</sup>	Ref. no.	Pack	
20	9	0.56	1.12	2.2	4	4	1	0	MC1I310ATD	100572	10	MC1K310ATD	100576	10
							0	1	MC1I301ATD	100573	10	MC1K301ATD	100577	10
20	12	0.75	2	3	5.5	5.5	1	0	MC2I310ATD	100559	10	MC2K310ATD	103590	10
							0	1	MC2I301ATD	100538	10	MC2K301ATD	103591	10
<b>Spare coil</b>									MB0ID	100470	10	MB0KD	100471	10



- (1) No possibility of adding instantaneous auxiliary contact blocks.
- (2) Facility to mount an instantaneous auxiliary contact block of two contacts or two instantaneous auxiliary contact blocks of one contact.
- (3) Electrical endurance AC-3:  
 MC0... (6A) = 1.2 x 10<sup>6</sup> operations.  
 MC1... (9A) = 0.85 x 10<sup>6</sup> operations.  
 MC2... (12A) = 0.6 x 10<sup>6</sup> operations.

Multipack. Series M

To reduce the amount of waste packaging material and to save time during installation, we offer the opportunity to order contactors in a multipack without the individual packaging.

Product	Type	Standard pack	Multipack (1)
Contactors	MC1...MC2a	20	40

(1) The quantity ordered must be a multiple of the quantity in each multipack (with the same frame/size and coil voltage)

How to order

To order a multipack, add the suffix **MP** to the standard catalogue number

Example	Standard pack	Multipack
	MCOA310ATN	MCOA310ATN MP (40 pieces)



Four poles contactors



Max.oper.current Non-inductive load AC1 <sup>(2)</sup> A	Motors <440V, 3 ~ 50/60Hz AC3 <sup>(3)</sup> A	Admissible power AC3					Poles	Control circuit: Alternating current		Control circuit: Direct current		
		1-phase		3-phase				Cat. no. <sup>(1)</sup>	Pack	Cat. no. <sup>(1)</sup>	Pack	
		115V	220V	220V	380V	500V			Ref. no. see bottom			
		HP	HP	HP	HP	HP			Ref. no. see bottom			
<b>Screw terminal</b>												
20	9	<b>AC1</b>					4	0	MC1A400AT	20	MC1C400AT	10
		2.3	4.4	7.5	13	17	2	2	MC1AB00AT	20	MC1CB00AT	10
		-	-	-	-	-	0	4	MC1AA00AT	20		
		<b>AC3</b>										
		0.56	1.12	2.2	4	4						
		0.75	1.5	3	5.5	5.5						
20	12	<b>AC1</b>					4	0	MC2A400AT	20	MC2C400AT	10
		2.3	4.4	7.5	13	17	2	2	MC2AB00AT	20	MC2CB00AT	10
		-	-	-	-	-						
		<b>AC3</b>										
		0.75	2	3	5.5	5.5						
		1	2.6	4	7.3	7.3						
<b>Terminal: faston 2x2.8 insulated <sup>(5)</sup></b>												
16 <sup>(4)</sup>	9	<b>AC1</b>					4	0	MC1A400AF	20	MC1C400AF	10
		2.3	4.4	7.5	13	17	2	2	MC1AB00AF	20	MC1CB00AF	10
		-	-	-	-	-	0	4	MC1AA00AF	20		
		<b>AC3</b>										
		0.56	1.12	2.2	4	4						
		0.75	1.5	3	5.5	5.5						
<b>Terminal: printed circuit</b>												
20	9	<b>AC1</b>					4	0	MC1A400AI	20	MC1C400AI	10
		2.3	4.4	7.5	13	17	2	2	MC1AB00AI	20	MC1CB00AI	10
		-	-	-	-	-	0	4	MC1AA00AI	20		
		<b>AC3</b>										
		0.56	1.12	2.2	4	4						
		0.75	1.5	3	5.5	5.5						
<b>Spare coil</b>								MB0A	10	MB0C	10	

- (1) To complete the catalogue number, replace the symbol ♦ by the code corresponding to the voltage and frequency of the control circuit (see A.44)
- (2) Electrical endurance AC-1: MC1... 0.3 x 10<sup>6</sup> operations  
MC2... 0.35 x 10<sup>6</sup> operations
- (3) Electrical endurance AC-3: MC1... (9A) = 0.85 x 10<sup>6</sup> operations  
MC2... (12A) = 0.6 x 10<sup>6</sup> operations
- (4) Terminal with wire 1.5 mm<sup>2</sup>: le = 16A  
with wire 1 mm<sup>2</sup>: le = 10A  
Insulated terminal type B 2.8 x 0.8 and wire of 1 mm<sup>2</sup> le = 8A in accordance with DIN 46247.
- (5) Faston 1 x 6.3 terminals on request, (replace letter F by H in the catalogue number).

For reference numbers, see chapter X, pg. X.2

Order codes

Intro

A

B

C

D

E

F

G

H

I

J/X



Instantaneous auxiliary contact blocks

Front mounting



Number contacts	Combinations with basic contactor 10E	Contacts in acc. with EN 50012	Contacts in acc. with EN 50005	Aux. contacts		Cat. no.	Ref. no.	Pack
<p>• Two or four additional contacts, to cover combinations of 3 or 5 contacts without increasing the surface area of the basic contactor</p>								
<b>Screw terminal</b>								
2	21E	11		1	1	MACN211AT	100999	10
2	12E	02		0	2	MACN202AT	100998	10
2			20	2	0	MARN220AT	100994	10
2			11	1	1	MARN211AT	100993	10
2			02	0	2	MARN202AT	100992	10
4	41E	31		3	1	MACN431AT	100997	10
4	32E	22		2	2	MACN422AT	100996	10
4	23E	13		1	3	MACN413AT	100995	10
4			40	4	0	MARN440AT	100991	10
4			31	3	1	MARN431AT	100990	10
4			22	2	2	MARN422AT	100989	10
4			13	1	3	MARN413AT	100988	10
4			04	0	4	MARN404AT	100987	10
<b>Ring terminal</b>								
2	21E	11		1	1	MACN211AR	103557	10
2	12E	02		0	2	MACN202AR	103558	10
2			20	2	0	MARN220AR	103349	10
2			11	1	1	MARN211AR	103350	10
2			02	0	2	MARN202AR	103351	10
4	41E	31		3	1	MACN431AR	103559	10
4	32E	22		2	2	MACN422AR	103560	10
4	23E	13		1	3	MACN413AR	103561	10
4			40	4	0	MARN440AR	103352	10
4			31	3	1	MARN431AR	103353	10
4			22	2	2	MARN422AR	103354	10
4			13	1	3	MARN413AR	103355	10
4			04	0	4	MARN404AR	103300	10

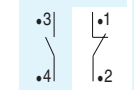

- Contactors
- Intro
- A
- B
- C
- D
- E
- F
- G
- H
- I
- J/X



Instantaneous auxiliary contact blocks (continued)

Lateral mounting



Number contacts	Combinations with basic contactor 10E	Contacts in acc. with EN 50012	Contacts in acc. with EN 50005	Aux. contacts +3   +4 +1   +2	Cat. no.	Ref. no.	Pack
-----------------	--	--------------------------------	--------------------------------	-------------------------------------	----------	----------	------

• One or two additional blocks, to cover combinations of 1 or 2 contacts without increasing the height of the basic unit contactor

Screw terminal							
1	20	10		1	0	MACL110AT	100560 10
1	11E	01		0	1	MACL101AT	100561 10

Ring terminal							
1	20	10		1	0	MACL110AR	103555 10
1	11E	01		0	1	MACL101AR	103556 10

Terminal: faston 2x2.8 insulated (1)							
1	20	10		1	0	MACL110AF	100562 10
1	11E	01		0	1	MACL101AF	100563 10

Terminal: printed circuit							
1	20	10		1	0	MACL110AI	100564 10
1	11E	01		0	1	MACL101AI	100565 10

• One or two additional blocks, when up to 6 or 7 contacts are needed (combination possible with frontal blocks)  
 • One or two additional blocks on both sides, to cover up to five contacts (combination possible only with lateral blocks)

Screw terminal							
1			10	1	0	MARL110ATS	100519 10
1			01	0	1	MARL101ATS	100520 10

Ring terminal							
1			10	1	0	MARL110ARS	103299 10
1			01	0	1	MARL101ARS	103298 10

Terminal: faston 2x2.8 insulated (1)							
1			10	1	0	MARL110AFS	100521 10
1			01	0	1	MARL101AFS	100522 10

Terminal: printed circuit							
1			10	1	0	MARL110AIS	100523 10
1			01	0	1	MARL101AIS	100524 10

(1) Terminal with wire 1 mm<sup>2</sup>: Ie = 10A  
 Insulated terminal type B 2.8 x 0.8 with wire 1 mm<sup>2</sup>: Ie = 8A, in accordance with DIN 46247

Order codes

Intro

A

B

C

D

E

F

G

H

I

J/X









### Direct-on-line starters

#### 6 to 12A (AC-3)

- Power circuit: up to 690V AC
- Control circuit: up to 600V AC
- Polycarbonate enclosure (IP40 - IP65)
  - Shock resistance
  - Total insulation  $\square$
  - 4 knock-out input holes PG13.5
  - Cable entry in the base
- Terminals protected against accidental contact
- 16 setting ranges from 0.11 up to 14A
- Start contact block

#### Series M - Direct-on-line starters

	Push-buttons	Protection degree	Cat. no.	Ref. no	Pack
Empty boxes	Start/Stop + Reset	IP40	MG0004PATO	209780	1
		IP65	MG0006PATO	209781	1
	Reset only	IP40	MG0004RATO	137567	1
		IP65	MG0006RATO	116402	1
	Start/Emergency stop	IP40	MG0004QATO	137566	1
		IP65	MG0006QATO	116074	1
Start contact block	Laterally mounted to the contactor, allowing the electrical operation the box push-button which incises on it.		MAGL110AT	100608	1

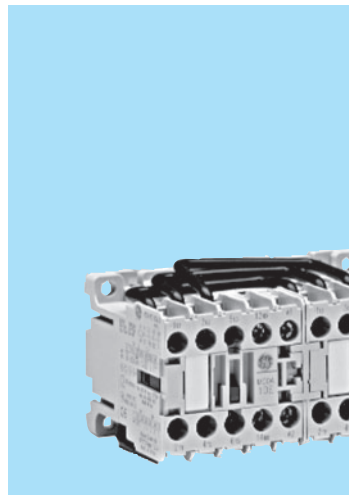

### Reversing starters

#### 6 to 12A (AC-3)

- Power circuit: up to 690V AC
- Control circuit: up to 600V AC  
up to 250V DC
- Assembled versions on request.
- Screw and push-on terminals protected against accidental contact.
- Protection degree IP20 in accordance with EN 60529.
- Facility to mount instant and timed auxiliary contact blocks and voltage suppressor blocks.

#### Series M - Reversing starters

	Description	For use with contactor	ac/dc	Cat. no.	Ref. no.	Pack.
Wiring kits for reversing starters	Suitable to be used with link modules	MC1., MC2..	ac/dc	WKMIU	101421	1
	Upper and lower connections without overload relays					

Wiring diagrams ● page A.134  
Dimensions ● page A.137

Order codes

Intro

A

B

C

D

E

F

G

H

I

J/X



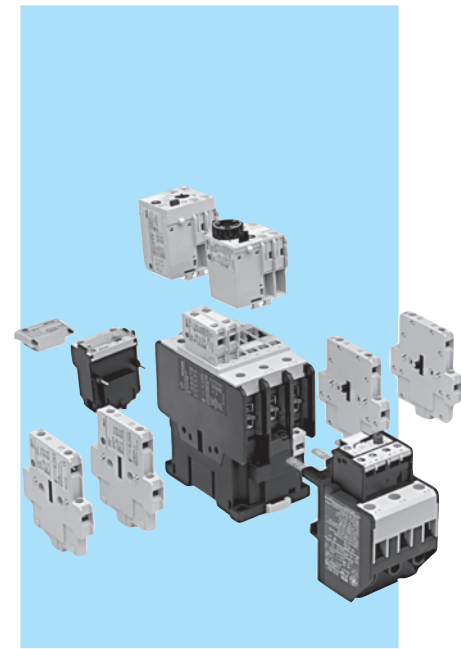

### Three and four pole contactors 9 to 105A (AC3) 25 to 140A (AC1)

- Control circuit: Alternating current up to 690V  
Direct current up to 440V
- Terminal numbering in accordance with EN 50005 and EN 50012
- Fixing by clipping onto 35mm DIN rail EN 50022-35 or by screws
- Screws protected against accidental contact in accordance with VDE 0106 T.100, VBG4.
- Ring terminal version
- Three coil terminals
- Mounting possibilities of front/side instantaneous auxiliary contact blocks, timed auxiliary contact blocks, mechanical latch, transient suppressor block and interface modules.
- Degree of protection: IP20 to CL00 ... CL02  
IP10 to CL25 ... CL10
- Maximum number of auxiliary contacts: 4 for CL00 ... CL25  
6 for CL04 ... CL45  
8 for CL06 ... CL10

#### Standards

IEC/EN 60947-1	CSA 22.2/14
IEC/EN 60947-4-1	NFC 63-110
IEC/EN 60947-5-1	ASE 1025
EN 50005	VDE 0660/102
UL 508	CENELEC HD 419
NEMA ICS 1	
BS 5424 & 775	

#### Approvals

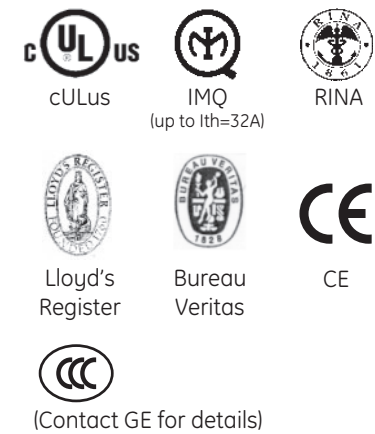

- Order codes ● pg. A.53
- Auxiliary contact blocks ● pg. A.57
- Accessories ● pg. A.58
- Technical data ● pg. A.91
- Terminal numbering ● pg. A.99
- Dimensions ● pg. A.112

#### Standard voltages

To complete the catalogue number, replace the symbol ♦ by the code corresponding to the voltage and frequency of the control circuit.

##### Alternating current (V). Dual-frequency coil

♦	1	2	9	3	4	5	6	7	13	8	15
AC	24	42	48	110	120	220	230	240	400	440	480
50/60Hz	115										

##### Alternating current (V).

♦	E	K	L	N	T	U	W	Y	Z
AC	32	127		220		380	415	500	660
50Hz				230		400			690
AC			208	277	380	480	460	600	
60Hz									

##### Direct current (V)

For contactors type CL...D / Operating limits: 0.80 ... 1.10 x Us

♦	B	D	E	F	G	H	I	J	K	N	P	R	T	X
Voltage	12	24	36	42	48	60	72	110	120	220	230	240	250	440
	125													

Coil with electronic module for contactors CL...E (can also be used with alternating current)

♦	D	F	H	J	N	Y
Voltage	24	42	60	110	220	440
	28	48	72	125	250	

##### Direct current (V). Coil with wide voltage range (0.70 ... 1.30 x Us)

For contactors type CL...D

♦	WB	WD	WE	WF	WG	WH	WI	WJ	WK	WN	WP	WR	WT	WX
DC	12	24	33	42	48	60	72	110	125	220	230	240	250	440

Maximum number of add-on auxiliary contact blocks:

##### Coil with electronic module for contactors CL...E

♦	WD	WE	WF	WH	WJ	WN
Voltage	24	33	48	72	110	220

CL00D...CL02D : 2NO or 1NC  
CL03D...CL45D : 1NO and 1NC  
CL05D...CL10D : 4NO or 2NC  
CL05E...CL10E : 4 cont. aux.

Different auxiliary contact configurations, contact us.



Three pole contactors. Screw terminal

Max.oper.current Non- inductive load	Motors <440V, 3~ 50/60Hz AC3 AC3 A	Admissible power AC3				Electrical endurance Operations	Aux. contacts	Control circuit: Alternating current		Control circuit: Direct current		Control circuit: Coil with electronic module (AC/DC)	
		220V 230V	380V 400V	415V 440V	500V 440V			Cat. AC3	Cat. no. (1)	Pack (3)	Cat. no. (1)	Pack (3)	Cat. no. (1)
25	9	2.2 3	4 5.5	4 5.5	5.5 7.5	2x10 <sup>6</sup>	1 0	0 0	CL00A310T CL00A301T	5 5	CL00D310T CL00D301T	10 10	- -
25	12	3 4	5.5 7.5	5.5 7.5	7.5 10	2x10 <sup>6</sup>	1 0	0 1	CL01A310T CL01A301T	5 5	CL01D310T CL01D301T	10 10	- -
32	18	4 5.5	7.5 10	7.5 10	10 13.5	1.7x10 <sup>6</sup>	1 0	0 1	CL02A310T CL02A301T	5 5	CL02D310T CL02D301T	10 10	- -
45	25	7.5 10	11 15	11 15	15 20	1.2x10 <sup>6</sup>	0 0	0 0	CL25A300T	5	CL25D300T	10	-
45	25	7.5 10	12 16	12 16	15 20	2x10 <sup>6</sup>	1 0	0 1	CL03A310M CL03A301M	10 10	CL03D310M CL03D301M	10 10	- -
60	32	9 12	16 22	16 22	18.5 25	2x10 <sup>6</sup>	1 0	0 1	CL04A310M CL04A301M	10 10	CL04D310M CL04D301M	10 10	- -
60	40	11 15	18.5 25	22 30	25 34	2x10 <sup>6</sup>	0 0	0 0	CL45A300M	10	CL45D300M	10	-
90	50	15 20	22 30	25 34	30 40	1.8x10 <sup>6</sup>	0 0	0 0	CL06A300M	1	CL06D300M	1	CL06E300M
110	65	18.5 25	30 40	37 50	40 55	1.7x10 <sup>6</sup>	0 0	0 0	CL07A300M	1	CL07D300M	1	CL07E300M
110	80	22 30	37 50	45 60	45 60	1.5x10 <sup>6</sup>	0 0	0 0	CL08A300M	1	CL08D300M	1	CL08E300M
140	95	25 34	45 60	50 68	55 75	1.7x10 <sup>6</sup>	0 0	0 0	CL09A300M	1	CL09D300M	1	CL09E300M
140	105	30 40	55 75	55 75	65 88	1.5x10 <sup>6</sup>	0 0	0 0	CL10A300M	1	CL10D300M	1	CL10E300M
Spare coils						CL00 - CL25	LB1A		5	LB1D	5	-	
						CL03 - CL45	LB3A		5	LB3D	5	-	
						CL06 - CL10	LB4A		5	LB4D	1	-	
						coil + electronic module CL06E - CL10E						LB4E	1

(1) To complete the catalogue number, replace the symbol ♦ by the code corresponding to the voltage and frequency of the control circuit (see A.52).  
 (2) Equipped with two blocks BCLF  
 (3) Multipack, see below

Multipack. Series M and Series CL

To reduce the amount of waste packaging material and to save time during installation, we offer the opportunity to order contactors in a multipack without the individual packaging.

Product	Type	Standard pack	Multipack (1)
Contactors	CL00A...CL25A...	20	40
	CL03...CL45...	10	20

(1) The quantity ordered must be a multiple of the quantity in each multipack (with the same frame/size and coil voltage)

How to order

For reference numbers, see chapter X, pg. X.4

To order a multipack, add the suffix MP to the standard catalogue number

Example	Standard pack	Multipack
	CL03A400MJ	CL03A400MJ MP (20 pieces)

Order codes

Intro

A

B

C

D

E

F

G

H

I

J/X



Three pole contactors. Ring terminal

Max.oper.current Non- inductive load AC1 A	Motors <440V, 3~ 50/60Hz AC3 A	Admissible power AC3				Electrical endurance Cat. AC3 Operations	Aux. contacts		Control circuit: Alternating current		Control circuit: Direct current	
		220V 230V	380V 400V	415V 440V	500V		kW HP	kW HP	kW HP	kW HP	Cat. no. (1)	Pack (2)
25	9	2.2 3	4 5.5	4 5.5	5.5 7.5	2x10 <sup>6</sup>	1 0	0 1	CL00A310R CL00A301R	5	CL00D310R CL00D301R	10
25	12	3 4	5.5 7.5	5.5 7.5	7.5 10	2x10 <sup>6</sup>	1 0	0 1	CL01A310R CL01A301R	5	CL01D310R CL01D301R	10
32	18	4 5.5	7.5 10	7.5 10	10 13.5	1.7x10 <sup>6</sup>	1 0	0 1	CL02A310R CL02A301R	5	CL02D310R CL02D301R	10
45	25	7.5 10	11 15	11 15	15 20	1.2x10 <sup>6</sup>	0	0	CL25A300R	5	CL25D300R	10
45	25	7.5 10	12 16	12 16	15 20	2x10 <sup>6</sup>	1 0	0 1	CL03A310R CL03A301R	10	CL03D310R CL03D301R	10
60	32	9 12	16 22	16 22	18.5 25	2x10 <sup>6</sup>	1 0	0 1	CL04A310R CL04A301R	10	CL04D310R CL04D301R	10
60	40	11 15	18.5 25	22 30	25 34	2x10 <sup>6</sup>	0	0	CL45A300R	10	CL45D300R	10
90	50	15 20	22 30	25 34	30 40	1.8x10 <sup>6</sup>	0	0	CL06A300R	1	CL06D300R	1
110	65	18.5 25	30 40	37 50	40 55	1.7x10 <sup>6</sup>	0	0	CL07A300R	1	CL07D300R	1
110	80	22 30	37 50	45 60	45 60	1.5x10 <sup>6</sup>	0	0	CL08A300R	1	CL08D300R	1
140	95	25 34	45 60	50 68	55 75	1.7x10 <sup>6</sup>	0	0	CL09A300R	1	CL09D300R	1
140	105	30 40	55 75	55 75	65 88	1.5x10 <sup>6</sup>	0	0	CL10A300R	1	CL10D300R	1

Spare coils	CL00 - CL25	LB1A	5	LB1D	5
	CL03 - CL45	LB3A	5	LB3D	5
	CL06 - CL10	LB4A	5	LB4D	1

(1) To complete the catalogue number, replace the symbol ♦ by the code corresponding to the voltage and frequency of the control circuit (see A.52).  
 (2) Multipack, see A.53

For reference numbers, see chapter X, pg. X.4



Four pole contactors. Screw terminal



Max.oper.current Non-inductive loads		Admissible power AC1				Electrical endurance Cat. AC1 Operations	Power contacts		Control circuit: Alternating current		Control circuit: Direct current		Control circuit: Coil with electronic module (AC/DC)	
AC1 A	AC3 A	220V kW	380V kW	415V kW	500V kW		4	0	Cat. no. (1)	Pack (2)	Cat. no. (1)	Pack (2)	Cat. no. (1)	Pack (2)
		230V	400V	440V				Ref. no. see bottom		Ref. no. see bottom		Ref. no. see bottom		
25	12	9.5	16.5	18	21.5	1.5x10 <sup>6</sup>	4	0	CL01A400T♦	5	CL01D400T♦	10	-	
32	18	12	22	23	27.5	1.5x10 <sup>6</sup>	4	0	CL02A400T♦	5	CL02D400T♦	10	-	
45	25	17	29	32	39	2x10 <sup>6</sup>	4	0	CL03A400M♦	10	CL03D400M♦	10	-	
60	32	22.5	39.5	43	52	1.5x10 <sup>6</sup>	4	0	CL04A400M♦	10	CL04D400M♦	10	-	
90	50	34	59	64	78	1.5x10 <sup>6</sup>	4	0	CL05A400M♦	1	CL05D400M♦	1	CL05E400M♦	
110	65	42	72.5	79	95	1.8x10 <sup>6</sup>	4	0	CL07A400M♦	1	CL07D400M♦	1	CL07E400M♦	
140	95	53	92	100	121	1.8x10 <sup>6</sup>	4	0	CL09A400M♦	1	CL09D400M♦	1	CL09E400M♦	



Max.oper.current Non-inductive loads		Admissible power AC3				Electrical endurance Cat. AC3 Operations	Power contacts		Control circuit: Alternating current		Control circuit: Direct current		Control circuit: Coil with electronic module (AC/DC)	
AC1 A	Motors <440V, 3~ 50/60Hz AC3 A	220V kW	380V kW	415V kW	500V kW		2	2	Cat. no. (1)	Pack (2)	Cat. no. (1)	Pack (2)	Cat. no. (1)	Pack (2)
		230V	400V	440V				Ref. no. see bottom		Ref. no. see bottom		Ref. no. see bottom		
25	12	3 4	5.5 7.5	5.5 7.5	7.5 10		2	2	CL01AB00T♦	5	CL01DB00T♦	5	-	
32	18	4 5.5	7.5 10	7.5 10	10 13.5		2	2	CL02AB00T♦	5	CL02DB00T♦	5	-	
45	25	7.5 10	12 16	12 16	15 20		2	2	CL03AB00M♦	10	CL03DB00M♦	10	-	
60	32	9 12	16 22	16 22	18.5 25		2	2	CL04AB00M♦	10	CL04DB00M♦	10	-	
90	40	11 15	18.5 25	22 30	25 34		2	2	CL05AB00M♦	1	CL05DB00M♦	1	CL05EB00M♦	
110	65	18.5 25	30 40	37 50	40 55		2	2	CL07AB00M♦	1	CL07DB00M♦	1	CL07EB00M♦	
110	80	22 30	37 50	45 60	45 60		2	2	CL08AB00M♦	1	CL08DB00M♦	1	CL08EB00M♦	

Spare coils



CL00 - CL25	LB1A ♦	5	LB1D ♦	5	-
CL03 - CL45	LB3A ♦	5	LB3D ♦	5	-
CL05A - CL08A	LB4A ♦	5	LB4D ♦	1	-
Coil + Electronic module CL05E - CL08E	LB4E ♦	1	-	-	LB4E ♦

(1) To complete the catalogue number, replace the symbol ♦ by the code corresponding to the voltage and frequency of the control circuit (see A.52).  
 (2) Multipack, see A.53

Order codes

Intro

A

B

C

D

E

F

G

H

I

J/X

For reference numbers, see chapter X, pg. X.4



Four poles. Ring terminal



Max.oper.current Non-inductive load	AC1 A	AC3 A	Admissible power AC1				Electrical endurance Operations	Power contacts	Control circuit: Alternating current		Control circuit: Direct current		
			220V 230V	380V 400V	415V 440V	500V			kW	kW	kW	kW	Cat. no. (1)
25	12	12	9.5	16.5	18	21.5	1.5x10 <sup>6</sup>	4	0	CL01A400R♦	5	CL01D400R♦	10
32	18	18	12	22	23	27.5	1.5x10 <sup>6</sup>	4	0	CL02A400R♦	5	CL02D400R♦	10
45	25	25	17	29	32	39	2x10 <sup>6</sup>	4	0	CL03A400R♦	10	CL03D400R♦	10
60	32	32	22.5	39.5	43	52	1.5x10 <sup>6</sup>	4	0	CL04A400R♦	10	CL04D400R♦	10
90	50	50	34	59	64	78	1.5x10 <sup>6</sup>	4	0	CL05A400R♦	1	CL05D400R♦	1
110	65	65	42	72.5	79	95	1.8x10 <sup>6</sup>	4	0	CL07A400R♦	1	CL07D400R♦	1
140	95	95	53	92	100	121	1.8x10 <sup>6</sup>	4	0	CL09A400R♦	1	CL09D400R♦	1



Max.oper.current Non-inductive load	Motors <440V, 3~ 50/60Hz	AC3 A	Admissible power AC3				Power contacts	Control circuit: Alternating current		Control circuit: Direct current		
			220V 230V	380V 400V	415V 440V	500V		kW HP	kW HP	kW HP	kW HP	Cat. no. (1)
25	12	12	3	5.5	5.5	7.5	2	2	CL01AB00R♦	5	CL01DB00R♦	5
32	18	18	4	7.5	7.5	10	2	2	CL02AB00R♦	5	CL02DB00R♦	5
45	25	25	7.5	12	12	15	2	2	CL03AB00R♦	10	CL03DB00R♦	10
60	32	32	9	16	16	18.5	2	2	CL04AB00R♦	10	CL04DB00R♦	10

Spare coils





CL00 - CL25	LR1A ♦	5	LR1D ♦	5
CL03 - CL45	LR3A ♦	5	LR3D ♦	5
CL05A - CL08A	LR4A ♦	5	LR4D ♦	1

(1) To complete the catalogue number, replace the symbol ♦ by the code corresponding to the voltage and frequency of the control circuit (see A.52).  
 (2) Multipack, see A.53

For reference numbers, see chapter X, pg. X.4





Auxiliary contact blocks

Instantaneous		Number of contacts	Contacts				Type	Time	Cat. no.	Ref. no.	Pack
			•3 •4	•1 •2	•7 •8	•5 •6					
	Frontal mounting	Terminal: screw									
		1	1	0	0	0			BCLF10	104700	10
		1	0	1	0	0			BCLF01	104701	10
		1	0	0	1	0			BCLF10G	104702	10
	1	0	0	0	1			BCLF01G	104703	10	
	Terminal: ring terminal										
	1	1	0	0	0			BCRF10	108901	10	
	1	0	1	0	0			BCRF01	108902	10	
	Side mounting	Terminal: screw									
		2	2	0	0	0			BCLL20	104706	10
		2	1	1	0	0			BCLL11	104707	10
		For combinations of more than 4 front-mounted and 2 side-mounted auxiliary contact blocks									
	2	2	0	0	0			BRLL20	104704	10	
	2	1	1	0	0			BRLL11	104705	10	
	2	0	2	0	0			BRLL02	106622	10	
	Terminal: ring terminal										
2	0	0	1	1	Delay ON	0.1 - 30 sec.	BTLF30C	104709	10		
2	0	0	1	1	Delay ON	1 - 60 sec.	BTLF60C	104710	10		
2	0	0	1	1	Delay OFF	0.1 - 30 sec.	BTLF30D	104711	10		
2	0	0	1	1	Delay OFF	1 - 60 sec.	BTLF60D	104712	10		
Terminal: ring terminal											
2	0	0	1	1	Delay ON	0.1 - 30 sec.	BTRF30C	108903	10		
2	0	0	1	1	Delay ON	1 - 60 sec.	BTRF60C	108904	10		
2	0	0	1	1	Delay OFF	0.1 - 30 sec.	BTRF30D	108905	10		
2	0	0	1	1	Delay OFF	1 - 60 sec.	BTRF60D	108906	10		
Seaking cover protection for pneumatic timer								BTLFX	113001	5	

Pneumatic timer

	Front mounting	Terminal: screw									
		2	0	0	1	1	Delay ON	0.1 - 30 sec.	BTLF30C	104709	10
		2	0	0	1	1	Delay ON	1 - 60 sec.	BTLF60C	104710	10
		2	0	0	1	1	Delay OFF	0.1 - 30 sec.	BTLF30D	104711	10
	2	0	0	1	1	Delay OFF	1 - 60 sec.	BTLF60D	104712	10	
	Terminal: ring terminal										
	2	0	0	1	1	Delay ON	0.1 - 30 sec.	BTRF30C	108903	10	
	2	0	0	1	1	Delay ON	1 - 60 sec.	BTRF60C	108904	10	
2	0	0	1	1	Delay OFF	0.1 - 30 sec.	BTRF30D	108905	10		
2	0	0	1	1	Delay OFF	1 - 60 sec.	BTRF60D	108906	10		
Seaking cover protection for pneumatic timer								BTLFX	113001	5	

Accessories

		Number of contacts	Contacts				For use with:	Cat. no. <sup>(1)</sup>	Ref. no.	Pack
			•3 •4	•1 •2	•7 •8	•5 •6				
	Interlock	Mechanical								
		-	-	-	-	-	CL00 ... CL10	BELA	104723	5
	Mech./ electrical									
	2	0	2	-	-	CL00 ... CL10	BELA02	104724	5	
Support interlock										
Only for direct current contactors						CL00D...CL10D	SBELA	101017	5	
	Mechanical latch blocks	Frontal mounted to the contactor								
							CL00 ... CL10	RMLF ♦	see bottom	10
		♦	D	G	HC	J	N	U	Y	
50Hz		24, 32	42, 48		110, 115, 120, 127	220, 230, 240	380, 400, 415, 440, 480	500, 660/690		
60Hz		24, 32	48, 60		110, 115, 120, 127	208, 220, 240, 277	380, 400, 415, 440, 480	600		
DC		24, 32, 36	42, 48	60, 72	110, 120, 125	220, 230, 240, 250	440			

1) To complete the catalogue number, replace the symbol ♦ by the code corresponding to the voltage and frequency of the control circuit (see A.52).

For reference numbers, see chapter X, pg. X.4



Order codes

Intro

A

B

C

D

E

F

G

H

I

J/X

Accessories

	For use with:	Type	Control circuit	Ue	Cat. no.	Ref. no.	Pack
 <p><b>Transient voltage suppressor block</b></p>	Fixation to the coil terminals, that allows simultaneous use with the auxiliary contact blocks.						
	CL00 ... CL45	R/C	AC	12V ... 48V	<b>BSLR2G</b>	104713	10
	CL00 ... CL45	R/C	AC	50V ... 127V	<b>BSLR2K</b>	104714	10
	CL00 ... CL45	R/C	AC	130V ... 250V	<b>BSLR2R</b>	104715	10
	CL05A ... CL10A	R/C	AC	12V ... 48V	<b>BSLR3G</b>	104716	10
	CL05A ... CL10A	R/C	AC	50V ... 127V	<b>BSLR3K</b>	104717	10
	CL05A ... CL10A	R/C	AC	130V ... 250V	<b>BSLR3R</b>	104718	10
	CL__D	Diode	DC	12V ... 600V	<b>BSLDZ</b>	104719	10
	CL00 ... CL10	Varistor	AC / DC	24V ... 48V	<b>BSLV3G</b>	104720	10
	CL00 ... CL10	Varistor	AC / DC	50V ... 127V	<b>BSLV3K</b>	104721	10
	CL00 ... CL10	Varistor	AC / DC	130V ... 250V	<b>BSLV3R</b>	104722	10
	CL00 ... CL10	Varistor	AC / DC	277V ... 500V	<b>BSLV3U</b>	110836	10

	For use with:	Control circ.	Type	Time	Cat. no.	Ref. no.	Pack
 <p><b>Electronic timer module</b></p>	Fixation to the coil terminals, that allows simultaneous use with the auxiliary contact blocks.						
	CL00 ... CL10	24-250V AC/DC	delay ON	0.1 - 2 sec.	<b>BETL02C</b>	113602	5
	CL00 ... CL10	24-250V AC/DC	delay ON	1.5 - 45 sec.	<b>BETL45C</b>	113603	5
	CL00 ... CL10	24-250V AC/DC	delay OFF	0.1 - 2 sec.	<b>BETL02D</b>	113604	5
	CL00 ... CL10	24-250V AC/DC	delay OFF	1.5 - 45 sec.	<b>BETL45D</b>	113605	5

Accessories

	For use with:		Cat. no.	Ref. no.	Pack
<p><b>Identification</b></p>	CL00 ... CL10	Sheets of labels (sheets of 260 labels each)	<b>EAT 260</b>	100548	1
	CL00 ... CL10	Labelling plate base (50 pieces in one pack)	<b>SPR</b>	100549	1
<p><b>Pole terminal protector IPXXB</b></p>	CL03 ... CL04		<b>PTP04</b>	113850	8
	CL45		<b>PTP45</b>	113851	6
	CL05 ... CL08		<b>PTP08</b>	113852	8
	CL09 ... CL10		<b>PTP10</b>	113853	8

Spares

	For use with:	Number of sets	Type	Cat. no.	Ref. no.	Pack
<p><b>Contact kits</b></p>	CL03_3 /CL03_4	3	NO	<b>V31203B</b>	104743	1
	CL03_B	4	2NAO-2NC	<b>VB1203B</b>	133170	1
	CL04_3 /CL04_4	3	NO	<b>V31204B</b>	104745	1
	CL04_B	4	2NO-2NC	<b>VB1204B</b>	133885	1
	CL45_3	3	NO	<b>V31245B</b>	104758	1
	CL05_4	4	NO	<b>V31205B</b>	104747	1
	CL05_B	4	2NO-2NC	<b>VB1205B</b>	104748	1
	CL06_	3	NO	<b>V31206B</b>	104749	1
	CL07_3 /CL07_4	3	NO	<b>V31207B</b>	104750	1
	CL07_B	4	2NO-2NC	<b>VB1207B</b>	104751	1
	CL08_3 /CL08_4	3	NO	<b>V31208B</b>	104752	1
	CL08_B	4	2NO-2NC	<b>VB1208B</b>	104753	1
	CL09_	3	NO	<b>V31209B</b>	104754	1
	CL10_	3	NO	<b>V31210B</b>	104755	1







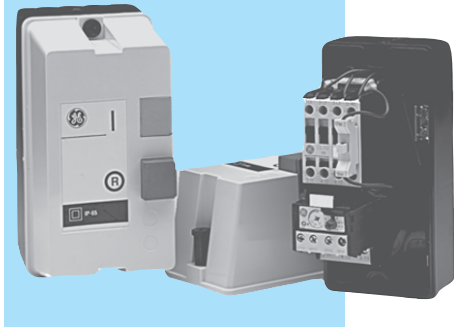

Direct-on-line starters

Series CL  
9 to 105A (AC-3)

- Power circuit: up to 690V AC
- Control circuit: up to 690V AC
- Protection degree IP00



Series CL - Direct-on-line starters

	For use with	Push-buttons	Protection degree	Cat. no.	Ref. no	Pack	
 <p>Empty boxes</p>	CL00, CL01, CL02	Start/Stop + Reset	IP40	LG0004P1B0	209344	1	
			IP65	LG0006P1B0	200004	1	
		Without push-buttons	IP40	LG0004S1B0	209347	1	
			IP65	LG0006S1B0	116011	1	
			Only Reset	IP40	LG0004R1B0	116651	1
				IP65	LG0006R1B0	116652	1
	CL25	Start/Stop + Reset	IP40	LG2504P1B0	100885	1	
			IP65	LG2506P1B0	101095	1	
		Only Reset	IP40	LG2504R1B0	116226	1	
	CL04	Start/Stop + Reset	IP65	LG2506R1B0	133611	1	
			IP40	LG0404P1B0	116653	1	
		Only Reset	IP65	LG0406P1B0	116656	1	
IP40			LG0404R1B0	133264	1		
CL25, CL04	Without push-buttons	IP65	LG0406R1B0	133265	1		
		IP40	LG0404S1B0	116996	1		
		IP65	LG0406S1B0	116997	1		
 <p>Neutral terminal</p>				BNL	104797	10	
 <p>Conversion to permanent control</p>	Pressure-fixed between push-buttons in direct-on-line enclosures for mechanical interlocking into permanent control.			EPL	104798	10	
 <p>Start contact block</p>	Pressure-fixed onto the front of direct-on-line starters allowing electrical operation using the start push-button on the enclosure			BMLF	104800	10	

Order codes

Intro

A

B

C

D

E

F

G

H

I

J/X



### Reversing starters

#### 9 to 40A (AC-3)

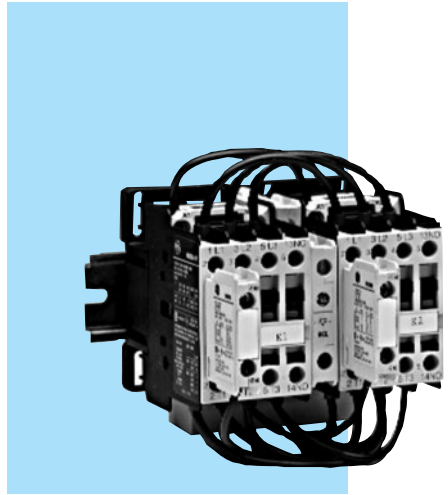

- Power circuit: up to 690V AC
- Control circuit: up to 690V AC
- IP00 version
- Polycarbonate enclosure (IP40 - IP65)
  - Shock resistance
  - Total insulation
  - 4 knock-out input holes
- Empty enclosures version
- Start contact block

#### Series CL - Reversing starters

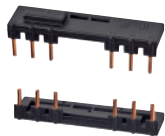
	Description	For use with contactor	ac/dc	Cat. no.	Ref. no.	Pack.
 Wiring kits for reversing starters	Suitable to be used with link modules Upper and lower connections without overload relays	CL00... CL01... CL02...	ac/dc	WKLI02P	101422	1
Plate	Metallic plate	CL06, CL07, CL08		WKI0910	241751	1
		CL08, CL09, CL10		WKI0608	241752	1

### Star-delta starters

#### Series CL

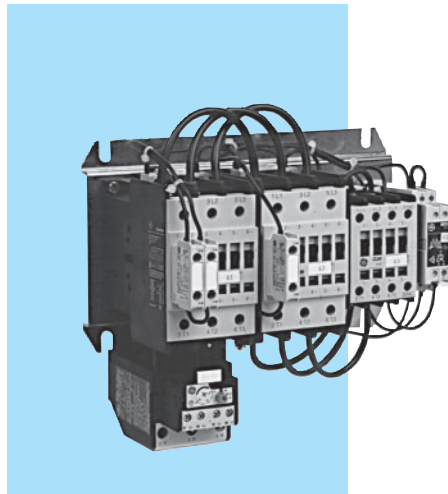

- Power circuit: up to 690V AC
- Control circuit: up to 690V AC
- Protection degree IP00
- Use delay setting by electronic relay NMET
- Terminals protected against accidental contact

#### Series CL - Star-delta starters

		Line-delta contactor	Cat. no.	Ref. no.	Pack
Busbar sets for power circuit		CL00	WKLE00	103238	1
		CL01, CL02	WKLE02	103241	1
Plate	Metallic plate	CL06, CL07, CL08	WLS0	103247	1
		CL09, CL10	WLS01	241750	1

Order codes [page A.60](#)  
 Wiring diagrams [page A.132](#)  
 Dimensions [page A.137](#)





Notes

Grid of dotted lines for notes.

Order codes

Intro

A

B

C

D

E

F

G

H

I

J/X



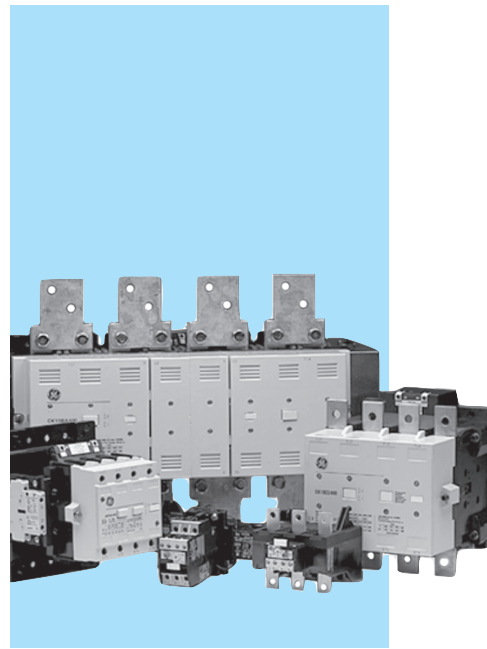

**Three and four pole contactors**  
**150 to 825A (AC3)**  
**200 to 1250A (AC1)**

- Control circuit: Alternating current up to 690V  
Direct current up to 500V
- Degree of protection IP00 (IPxxB with accessories)
- CK07...CK13: auxiliary and coil terminals originally protected against accidental contacts.  
Protection for power contacts on request (see accessories)
- Terminals protected against accidental contacts according to VDE 0106 T.100, VBG4.
- CK...E with electronic module suitable for DC and AC. (50/60Hz)
- CK contactors always provided with one auxiliary contact block BCLL11 (1NO+1NC)

**Standards**

IEC/EN 60947-1	CSA 22.2/14
IEC/EN 60947-4-1	CENELEC HD 419
IEC/EN 60947-5-1	NFC 63-110
EN 50005	ASE 1025
UL 508	UNE 20109
NEMA ICS 1	VDE 0660/102
BS 5424 & 775	

**Approvals/Marking**

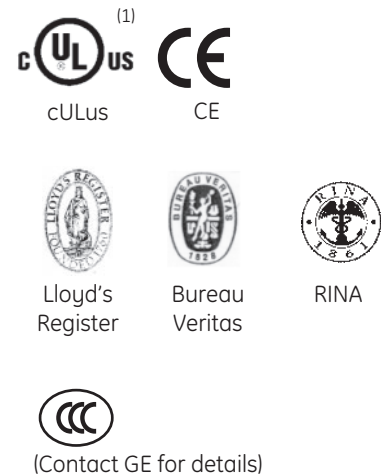

(Contact GE for details)

**Standard voltages**

To complete the catalogue number, replace the symbol ♦ by the code corresponding to the voltage and frequency of the control circuit.

**Alternating current (V)**

Three-pole contactors: CK75CA3..., CK08CA3..., CK85BA3...  
 Four-pole contactors: CK07BA4..., CK08BA4...

♦	C	D	F	G	H	I	J	K	M	N	R	S	T	U	V	W	X	Y	Z
50Hz		24	42	48			110	127		220	240			380		415	440	500	660
										230			400						690
60Hz	24		48		110	120			220	277		240	380	480	440				600

**Alternating current (V). Dual-frequency coil**

Three-pole contactors: CK75CA3..., CK08CA3..., CK85BA3...  
 Four-pole contactors: CK07BA4..., CK08BA4...

♦	1	2	3	6	13
50/60Hz	24	48	110	230	400

**Alternating current (V)**

Three-pole contactors: CK13BA3...  
 Four-pole contactors: CK13BA4...

♦	J	N	U	Y	Z
50/60Hz	110	220	380	480	600
	240	440	500	660	

**Control circuit with rectifier bridge**

♦	J	N	U
50Hz	110	220	380
	230	400	
60Hz	120	240	480

**Direct current (V). With electronic module (0.7 ... 1.3 x Us)**

Three-pole contactors: CK75CE3..., CK08CE3...

♦	WD	WE	WF	WH	WJ	WN
Voltage	24	33	48	72	110	220

**Alternating c. / Direct c. (V). With electronic module (0.8 ... 1.10 x Us)**

Three-pole & four-pole contactors: CK ..... E.....

♦	D	F	J	N	U	Y
Voltage	24	42	110	220	380	440
	28	48	127	250	415	500

(1) CK13 not UL

- Order codes ● pg. A.63
- Aux. contact blocks ● pg. A.64
- Accessories & Spares ● pg. A.65
- Technical data ● pg. A.102
- Dimensions ● pg. A.118



Three pole contactors



Max.oper.current Non-inductive loads AC1 A	Motors <440V, 3 ~ 50/60Hz AC3 A	Admissible power AC3					Electrical endurance Cat. AC3 Operations	Control circuit: Alternating current		Control circuit: A.C. / D.C.	
		220V 230V	380V 400V	415V 440V	440V 440V	500V		Cat. no. <sup>(1)</sup> Ref. no. see bottom	Pack	Cat. no. <sup>(1)</sup> Ref. no. see bottom	Pack
250	150	45 60	75 100	80 108	80 108	100 135	1.7x10 <sup>6</sup>	CK75CA311 ♦	1	CK75CE311 ♦	1
250	185	55 75	90 125	100 135	100 135	110 150	1.2x10 <sup>6</sup>	CK08CA311 ♦	1	CK08CE311 ♦	1
315	205	65 88	110 150	125 170	125 170	132 180	1.7x10 <sup>6</sup>	CK85BA311 ♦	1	CK85BE311 ♦	1
315	250	75 100	132 180	132 180	132 180	160 220	1.5x10 <sup>6</sup>	-		CK09BE311 ♦	1
450	309	90 125	160 220	160 220	185 250	200 270	1.1x10 <sup>6</sup>	-		CK95BE311 ♦	1
600	420	125 170	220 300	230 312	230 312	300 405	1x10 <sup>6</sup>	-		CK10CE311 ♦	1
700	550	160 220	280 380	315 425	315 425	400 540	0.8x10 <sup>6</sup>	-		CK11CE311 ♦	1
1000	700	220 300	375 510	400 540	425 580	480 650	0.7x10 <sup>6</sup>	-		CK12BE311 ♦	1
1250	825	250 340	450 610	450 610	450 610	500 680	0.7x10 <sup>6</sup> (2)	CK13BA311 ♦	1	-	

Spare coil	CK75CA3 ... CK08CA3	C12168 ♦	1	-
	CK85BA3	C04255 ♦	1	-
	CK13BA3	C08998 ♦	1	-
	Control circuit with incorporated rectifier bridge CK13BA3	C09120 ♦	1	-
Coil	CK75CE3 ... CK08CE3	-		KB4E ♦ 1
	CK85BE3 ... CK95BE3	-		KB5E ♦ 1
	CK12BE3	-		KB6E ♦ 1
	CK10CE3 ... CK11CE3	-		KB7E ♦ 1
Electronic module	CK75CE3 ... CK08CE3	-		KM4E ♦ 1
	CK85BE3 ... CK95BE3	-		KM5E ♦ 1
	CK12BE3	-		KM6E ♦ 1
	CK10CE3 ... CK11CE3	-		KM7E ♦ 1

(1) To complete the catalogue number, replace the symbol ♦ by the code corresponding to the voltage and frequency of the control circuit (see A.62).  
 (2) CK13 non allow the aux. block in right side.

Order codes

Intro

A

B

C

D

E

F

G

H

I

J/X

For reference numbers, see chapter X, pg. X.5



Four pole contactors

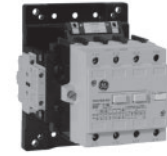

Max.oper. current	Admissible power						Electrical endurance	Control circuit: Alternating current	Control circuit: A.C. / D.C.			
	AC3		AC1						Cat. AC3	Cat. no. (1)	Pack	
Non-inductive loads AC1	380V	220V	380V	415V	440V	500V	Operations	Ref. no. see bottom	Ref. no. see bottom			
A	400V	230V	400V									
200	55	105	76	131	143	151	173	1x10 <sup>6</sup>	CK07BA41	1	CK07BE411	1
325	100	185	123	214	233	247	281	0.6x10 <sup>6</sup>	CK08BA411	1	CK08BE411	1
400	132	250	152	263	287	304	346	0.6x10 <sup>6</sup>	-		CK09BE411	1
500	160	309	191	329	359	380	415	0.6x10 <sup>6</sup>	-		CK95BE411	1
600	220	408	228	395	431	456	519	0.5x10 <sup>6</sup>	-		CK10CE411	1
700	280	530	266	460	503	533	606	0.4x10 <sup>6</sup>	-		CK11CE411	1
1000	375	680	381	658	719	762	866	0.4x10 <sup>6</sup>	-		CK12BE411	1
1250	450	800	476	822	898	952	1082	0.6x10 <sup>6</sup> (2)	CK13BA411	1		

Spare coil		Cat. no.	Pack	Ref. no.
	CK07BA4	C04255	1	-
	CK08BA4	C04787	1	-
	CK13BA4	C08998	1	-
	Control circuit with incorporated rectifier bridge CK13BA4	C09120	1	-
Coil		Cat. no.	Pack	Ref. no.
	CK07BE4	-		KB5E
	CK08BE4 ... CK95BE4, CK12BE4	-		KB6E
	CK10CE4 ... CK11CE4	-		KB7E
Electronic module		Cat. no.	Pack	Ref. no.
	CK07BE4	-		KM5E
	CK08BE4 ... CK95BE4, CK12BE4	-		KM6E
	CK10CE4 ... CK11CE4	-		KM7E

(1) To complete the catalogue number, replace the symbol ♦ by the code corresponding to the voltage and frequency of the control circuit (see A.62).  
 (2) CK13 non allow the aux. block in right side.

Auxiliary instantaneous contact block



Side mounting



Number of contacts	Contacts				Cat. no.	Ref. no.	Pack
	•3	•1	•7	•5			
2	0	0	0	BCLL20	104706	10	
2	1	1	0	BCLL11	104707	10	
2	1	1	0	BCLL11-K(1)	248083	10	
combinations of more than 2 blocks							
2	2	0	0	BRLL20	104704	10	
2	1	1	0	BRLL11	104705	10	
2	0	2	0	BRLL02	106622	10	

(1) For high shock/vibrations environments

For reference numbers, see chapter X, pg. X.5



Accessories

	For use with:	Mounting	Voltage	Ue	Cat. no.	Ref. no.	Pack	
 <p><b>Transient voltage suppressor</b></p>	Fixation to the coil terminals, that allows simultaneous use with the auxiliary contact blocks.							
	CK75 ... CK08		AC	24V - 48V	<b>BSLR3G</b>	104716	10	
	CK75 ... CK08		AC	50V - 127V	<b>BSLR3K</b>	104717	10	
	CK75 ... CK08		AC	130V - 240V	<b>BSLR3R</b>	104718	10	
	CK75 ... CK08		AC	227V - 500V	<b>BSLV3U</b>	110836	10	
	CK85 ... CK13		AC	24V	<b>KRC24</b>	104760	10	
	CK85 ... CK13		AC	260V	<b>KRC48/260</b>	104761	10	
	CK85 ... CK13		AC	415V	<b>KRC380/415</b>	104762	10	
	 <p><b>Mechanical interlock</b></p>	CK07B ... CK12	Horizontal			<b>BEKH</b>	104763	1
		CK07B ... CK95	Vertical			<b>BEKVS 1</b>	104786	1
CK10C ... CK12B		Vertical			<b>BEKVA 1</b>	104785	1	
CK13		Vertical			<b>BEKV</b>	104764	1	
<p><b>Pole terminal protection</b></p>	CK75C ... CK08C	1 pole. VDE0106			<b>CM1CA5F</b>	105200	1	
	CK85B ... CK12B	1 pole. VDE0106	Contactors 3P		<b>C09476</b>	104766	6	
	CK08B ... CK12B	1 pole. VDE0106	Contactors 4P		<b>C09479</b>	204800	8	
	CK75C ... CK08C	1 pole IPXXB			<b>PTPCK75</b>	103747	1 <sup>(1)</sup>	
	CK85B ... CK95B	1 pole IPXXB			<b>PTPCK95</b>	103748	3 <sup>(2)</sup>	
	CK10C ... CK12B	1 pole IPXXB			<b>PTPCK11</b>	103749	1 <sup>(1)</sup>	

(1) One phase  
(2) Three pole

Spares

	For use with:	Type		Cat. no.	Ref. no.	Pack
 <p><b>Contact kits</b></p>	One set consists of two fixed contacts, one moving contact and accessory parts. When contact replacement is needed, it is recommended to replace all the contacts at the same time.					
	CK07B	NA		<b>V1107BA</b>	113612	1
	CK75C	NA		<b>V1175CA</b>	113613	1
	CK08C	NA		<b>V1108CA</b>	113614	1
	CK08B	NA	Contactors 4P	<b>V1108BA</b>	113505	1
	CK85B	NA		<b>V1185BA</b>	113615	1
	CK09B	NA		<b>V1109BA</b>	113616	1
	CK09B	NA	Contactors 4P	<b>V1109BA</b>	113899	1
	CK95B	NA		<b>V1195BA</b>	113617	1
	CK10C	NA		<b>V1110CE</b>	113618	1
	CK11C	NA		<b>V1111CE</b>	113619	1
	CK12B	NA		<b>V1112BA</b>	113620	1
	CK13B	NA		<b>V1113BA</b>	113621	1

Order codes

Intro

A

B

C

D

E

F

G

H

I

J/X



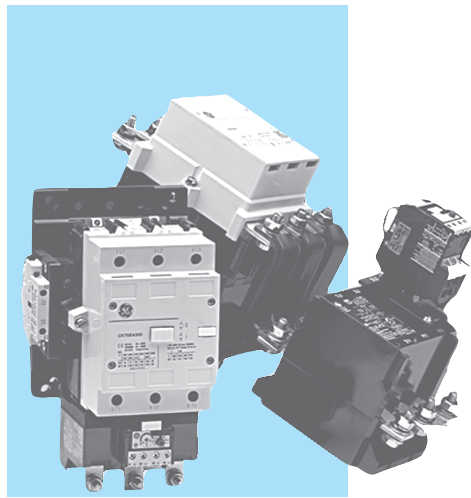

**Direct-on-line starters**

**150 to 825A (AC-3)**

- Power circuit: up to 1000V AC
- Control circuit: up to 690V AC
- Protection degree IP00
- Terminals protected against accidental contact: IP20
  - KG75 to KG12: Coil and auxiliary terminals with built-in protection  
Main terminals protector on request
  - KG13: Coil and auxiliary terminals with built-in protection

**Series CK - Direct-on-line starters. IP00**

			Cat. no.	Ref. no.	Pack
Connection sets	Busbar set for power circuit	CK85,CK09,CK95	KVP85G	104770	1
		CK10,CK11	KVP10G	104771	1
		CK12	KVP12G	104767	1
Plate	Metallic plate	CK85, CK09, CK95	PVP85G	241747	1
		CK10, CK11	PVP10G	241748	1
		CK12	PCP12G	241749	1

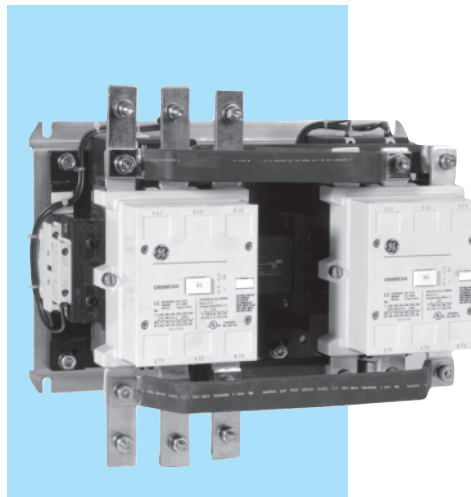

**Reversing starters**

**150 to 825A (AC-3)**

- Power circuit: up to 1000V AC
- Control circuit: up to 690V AC
- Protection degree IP00

**Series CK - Reversing starters. IP00**

	Description	For use with contactor	Cat. no.	Ref. no.	Pack.
Connection sets	Busbar set for power circuit	CK75, CK08	KVP75U	113627	1
		CK85, CK09, CK95	KVP85U	113628	1
		CK10, CK11	KVP10U	133374	1
		CK12	KVP12U	113630	1
	Busbar set for power circuit For assembly with thermal overload relay.	CK75, CK08	KVP75I	133370	1
		CK85, CK09, CK95	KVP85I	113631	1
		CK10, CK11	KVP10I	133371	1
		CK12	KVP12I	113633	1
Plate	Metallic plate	CK75, CK08	KVB75I	104690	1
		CK85, CK95	KVB95I	104691	1
		CK10, CK11	KVB10I	104692	1
		CK12	KVB12I	104693	1

Order codes ● page A.66-67  
 Wiring diagrams ● page A.135  
 Dimensions ● page A.138





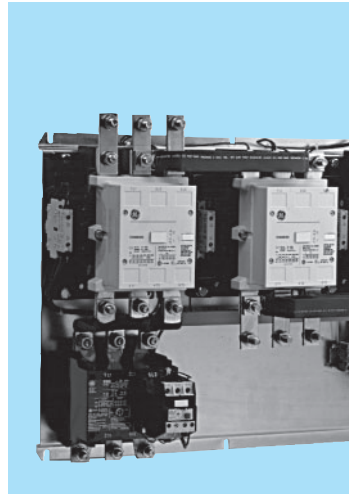

**Star-delta starters**

**Series CK**

- Power circuit: up to 1000V AC
- Control circuit: up to 690V AC
- Protection degree IP00
- Protection against accidental contacts: IP20
  - KE75: Built-in protection
  - KE08 - KE12: Coil and auxiliary terminals with built-in protection  
Main terminals protector on request
  - KE13: Coil and auxiliary terminals with built-in protection

**Series CK - Star-delta starters. IP00**

		Line-delta contactor	Star contactor	Cat. no.	Ref. no.	Pack
<b>Busbar sets for power circuit</b>		CK75, CK08	CK75, CK08	KVP75E	133378	1
		CK85, CK09, CK95	CK75, CK08	KVP08E	116212	1
		CK95	CK85, CK09, CK95	KVP85E	133379	1
		CK10, CK11	CK85, CK09, CK95	KVP95E	113637	1
		CK10, CK11	CK10, CK11	KVP10E	133380	1
		CK12	CK10, CK11	KVP12E	116235	1
<b>Plate</b>	Metallic plate	CK75, CK08		KVB75E	104694	1
		CK85, CK95		KVB95E	104695	1
		CK10, CK11		KVB10E	104597	1
		CK12		KVB12E	104587	1

Order codes

Intro

A

B

C

D

E

F

G

H

I

J/X



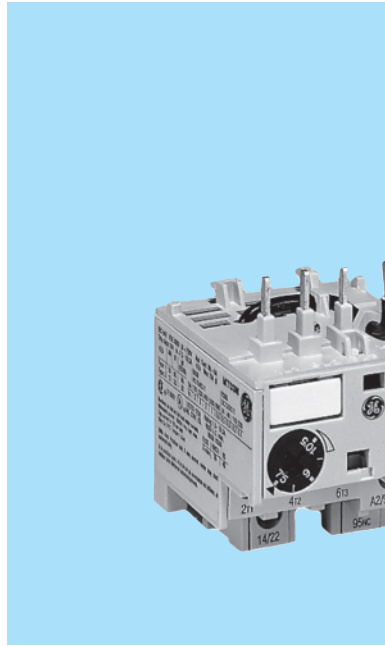

### Thermal overload relays for contactors from 0.11 to 14A

- Control circuit up to 690V
- Power circuit up to 690V
- Three-pole differential (phase unbalance protection)
- Automatic ambient temperature compensation between -25°C and +60°C
- Choice of manual or automatic reset
- Direct connection to contactor or independent mounting using accessories.
- Screw and Ring terminal versions
- Terminals protected against accidental contact in accordance with VDE 0106 T.100 and VBG4.
- Terminal numbering in accordance with EN 50005
- Degree of protection IP20 (EN 60529)
- Additional auxiliary contact block 1NO (with manual reset only)

#### Standards

IEC/EN 60947-4-1	CSA 22.2/14
IEC/EN 60947-5-1	NI C 63-650
UNE 115	VDE 0660
NFC 63-650	UL 508

#### General characteristics

- Thermal protection against balanced overload.
- Three-pole differential (phase unbalance protection).
- Automatic ambient temperature compensation.
- Front mounted selector for choosing utilisation current.
- Reset button, 2 positions :  
Manual(H) and Automatic(A) by turning the blue selector.
- Stop push button, independent of reset (red).
- Manual trip lever (tripping test).
- Tripping indicator (0-1).
- To facilitate wiring arrangements terminal 96 fits directly onto coil terminal (A2) and terminal 14/22 fits directly onto the feedback auxiliary contact.

#### Approvals/Marking



Order codes ● pg. A.69  
 Technical data ● pg. A.120  
 Dimensions ● pg. A.121



Thermal overload relays for contactors



For use with:	Setting range (regulation)		Fuse				Terminal: screw		Terminal: ring terminal		Pack
			aM		gL		Cat. no.	Ref. no.	Cat. no.	Ref. no.	
			Type 2	Type 1	Type 2	Type 1					
	min. A	max. A	A	A	A	A					
MC0...	0.11	0.17	0.5	0.5	0.5	0.5	<b>MT03A</b>	101000	<b>MT03RA</b>	103540	10
MC1...	0.17	0.26	0.85	1	1	1	<b>MT03B</b>	101001	<b>MT03RB</b>	103541	10
MC2...	0.26	0.43	1	2	2	4	<b>MT03C</b>	101002	<b>MT03RC</b>	103542	10
	0.43	0.65	1	4	2	8	<b>MT03D</b>	101003	<b>MT03RD</b>	103543	10
	0.65	1	2	6	4	12	<b>MT03E</b>	101004	<b>MT03RE</b>	103544	10
	0.85	1.3	2	6	4	12	<b>MT03F</b>	101005	<b>MT03RF</b>	103545	10
	1.1	1.6	2	10	4	16	<b>MT03G</b>	101006	<b>MT03RG</b>	103546	10
	1.35	2	4	10	6	16	<b>MT03H</b>	101007	<b>MT03RH</b>	103547	10
	1.7	2.4	4	16	6	25	<b>MT03I</b>	101008	<b>MT03RI</b>	103548	10
	2.2	3.2	4	20	6	32	<b>MT03J</b>	101009	<b>MT03RJ</b>	103549	10
	2.5	4	4	20	6	32	<b>MT03R</b>	101015			10
	3	4.7	6	20	10	32	<b>MT03K</b>	101010	<b>MT03RK</b>	103550	10
	4	6.3	10	32	16	50	<b>MT03L</b>	101011	<b>MT03RL</b>	103551	10
	5.5	8	12	50	20	63	<b>MT03M</b>	101012	<b>MT03RM</b>	103552	10
	7.5	10.5	16	50	25	80	<b>MT03N</b>	101013	<b>MT03RN</b>	103553	10
	10	14	20	32	32	100	<b>MT03P</b>	101014	<b>MT03RP</b>	103554	10

Accessories



Input terminals

Terminal	Cat. no.	Ref. no.	Pack
Screw	<b>MVE0T</b>	101020	5
Ring terminal	<b>MVE0R</b>	103562	5



Base

For separate mounting onto standard EN 50022-35 profile

<b>MVB0T</b>	101021	5
--------------	--------	---



Auxiliary contact block

Frontal fixing to the relay  
With trip indicator (0-I)  
One block per relay and only for manual reset

Screw	<b>MATV10AT</b>	101022	10
Ring terminal	<b>MATV10AR</b>	103563	10

Identification

Sheets of labels (sheets of 260 labels each)  
Labeling plate base (50 pieces in one pack)

<b>EAT 260</b>	100548	1
<b>SPR</b>	100549	1

Order codes

Intro

**A**

B

C

D

E

F

G

H

I

J/X



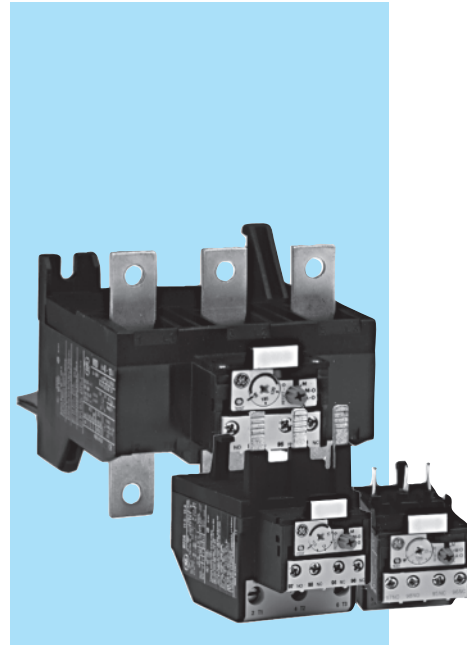

**Thermal overload relays  
for contactors from  
0.16 to 850A**

- Control circuit up to 690V AC
- Power circuit:
  - RT1, RT12: up to 690V
  - RT2, RT22, RT3, RT32, RT4/4L, RT5/5L & RT6/6L: up to 1000V
- Thermal protection against normal overloads.
- Three pole differential (phase unbalance protection).
- Protection against long starting times.
- Automatic ambient temperature compensation between - 25°C + 60°C.
- Front mounted test button.
- Trip indication.
- Independent auxiliary contacts with double rupture (1NO + 1NC).
- Function selector:
  - Manual RESET
  - Manual RESET and STOP
  - Automatic RESET with STOP
  - Automatic RESET without STOP

**Standards**

IEC/EN 60947-4-1	CSA 22.2/14
IEC/EN 60947-5-1	NI C 63-650
UNE 115	VDE 0660
NFC 63-650	UL 508
CEI 17-50	

**Approvals/Marking**

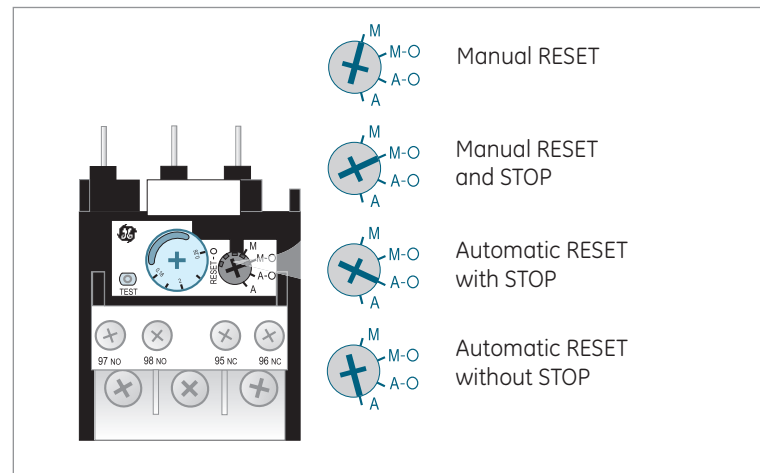
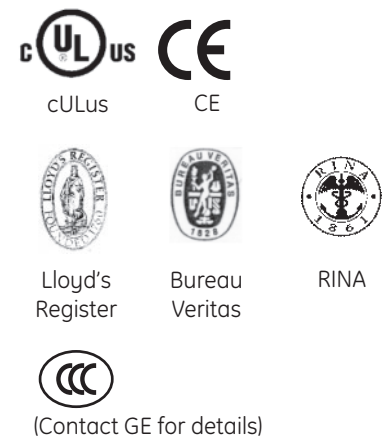

Order codes ● pg. A.71  
 Technical data ● pg. A.122  
 Dimensions ● pg. A.123



**Thermal overload relays for contactors**



	For use with:	Setting range (regulation)		Fuses <sup>(1)</sup>		Srew terminal		Ring terminal		Pack	
				aM	gL - gG						
		min. A	max. A	A	A	Cat. no.	Ref. no.	Cat. no.	Ref. no.		
<b>Class 10A</b>	CL00	0.16	0.26	2	2	RT1B	113700	RT1RB	114087	5	
	CL01	0.25	0.41	2	2	RT1C	113701	RT1RC	114088	5	
	CL02	0.4	0.65	2	2	RT1D	113702	RT1RD	114089	5	
	CL25	0.65	1.1	2	4	RT1F	113703	RT1RF	114090	5	
	CL03	1.0	1.5	4	6	RT1G	113704	RT1RG	114091	5	
	CL04	1.3	1.9	4	6	RT1H	113705	RT1RH	114092	5	
	CL45	1.8	2.7	6	10	RT1J	113706	RT1RJ	114093	5	
		2.5	4.0	8	16	RT1K	113707	RT1RK	114094	5	
		4.0	6.3	12	20	RT1L	113708	RT1RL	114095	5	
		5.5	8.5	16	20	RT1M	113709	RT1RM	114096	5	
		8.0	12.0	20	25	RT1N	113710	RT1RN	114097	5	
		10.0	16.0	25	35	RT1P	113711	RT1RP	114098	5	
		14.5	18.0	32	50	RT1S	113712	RT1RS	114099	5	
		17.5	22.0	40	50	RT1T	113713	RT1RT	114100	5	
		21.0	26.0	40	63	RT1U	113714	RT1RU	114101	5	
		25.0	32.0	50	80	RT1V	113715	RT1RV	114102	5	
	30.0	40.0	63	100	RT1W	113716	RT1RW	114103	5		
	<b>Class 10</b>	CL05	11.5	15.0	32	35	RT2A	113717	RT2RA	114104	1
		CL06	14.5	19.0	40	50	RT2B	113718	RT2RB	114132	1
		CL07	18.5	25.0	50	63	RT2C	113719	RT2RC	114106	1
CL08		24.0	32.0	63	100	RT2D	113720	RT2RD	114133	1	
CL09		30.0	43.0	80	125	RT2E	113721	RT2RE	114134	1	
		42.0	55.0	100	160	RT2G	113722	RT2RG	114109	1	
CL10		54.0	65.0	125	160	RT2H	113723	RT2RH	114146	1	
		64.0	82.0	125	200	RT2J	113724	RT2RJ	114136	1	
		78.0	97.0	125	200	RT2L	113725	RT2RL	114235	1	
90.0		110	160	250	RT2M	113726	RT2RM	114113	1		
<b>Class 20</b>	CL00	0.4	0.65	2	2	RT12D	139138	RT12RD	114060	5	
	CL01	0.65	1.1	2	4	RT12F	139139	RT12RF	114061	5	
	CL02	1	1.5	4	6	RT12G	139140	RT12RG	114062	5	
	CL25	1.3	1.9	4	6	RT12H	139141	RT12RH	114063	5	
		1.8	2.7	8	10	RT12J	139142	RT12RJ	114159	5	
	CL03	2.5	4.1	8	16	RT12K	113640	RT12RK	114114	5	
	CL04	4	6.3	12	20	RT12L	113641	RT12RL	114115	5	
		5.5	8.5	16	20	RT12M	113642	RT12RM	114116	5	
	CL45	8	12	20	35	RT12N	113643	RT12RN	114117	5	
		10	16	25	35	RT12P	113644	RT12RP	114118	5	
		14.5	18	32	50	RT12S	113645	RT12RS	114119	5	
		17.5	22	40	50	RT12T	113646	RT12RT	114120	5	
		21	26	40	63	RT12U	113647	RT12RU	114121	5	
		25	32	50	80	RT12V	113648	RT12RV	114122	5	
		30	40	63	100	RT12W	113649	RT12RW	114123	5	
		CL05	24	32	63	80	RT22D	113650	RT22RD	114124	1
			30	43	80	100	RT22E	113651	RT22RE	114141	1
			42	55	100	160	RT22G	113652	RT22RG	114126	1
	54		65	125	160	RT22H	113653	RT22RH	114127	1	
	CL08		64	82	125	200	RT22J	113654	RT22RJ	114128	1
	CL09		78	97	125	200	RT22L	113655	RT22RL	114143	1
	CL10		90	110	160	250	RT22M	113656	RT22RM	114130	1

(1) Most suitable fuse in accordance with IEC 60947-4-1.

(continued on page A.72)

Order codes

Intro

A

B

C

D

E

F

G

H

I

J/X



## Thermal overload relays for contactors (continued)

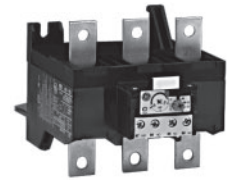

	For use with:	Setting range (regulation)		Fuses <sup>(1)</sup>		Cat.no. (Screw terminal)	Ref. no.	Pack	
		min.	max.	aM	gL - gG				
		A	A	A	A				
<b>Class 10</b>	CK75	55	80	125	200	RT3B	113727	1	
	CK08	63	90	125	200	RT3C	113728	1	
	Direct mounting	90	120	160	250	RT3D	113729	1	
		110	140	200	315	RT3E	113730	1	
		140	190	250	355	RT3F	113731	1	
		CK85	120	190	250	315	RT4N	113732	1
	CK09	175	280	315	400	RT4P	113733	1	
	CK95 <sup>(2)</sup>	200	310	400	500	RT4R	113734	1	
	CK10	120	190	250	315	RT5A	113750	1	
	CK11	175	280	315	400	RT5B	113751	1	
	CK12 <sup>(3)</sup>	250	400	500	630	RT5C	113752	1	
		315	500	630	800	RT5D	113753	1	
		430	700	800	1000	RT5E	113754	1	
CK13 <sup>(4)</sup>	500	850	100	1250	RT6A	113760	1		
<b>Class 20</b>	CK75	63	90	125	200	RT32C	113657	1	
	CK08	90	120	160	250	RT32D	113658	1	
	Direct	110	140	200	315	RT32E	113659	1	
	ounting	140	190	250	355	RT32F	113660	1	
<b>Class 30</b>	CL...	2,5	4	10	16	RT4LA	113735	1	
	CK...	4	6,5	12	20	RT4LB	113736	1	
	Mounting with screws	5,5	8,5	16	25	RT4LC	113737	1	
		7,5	11	20	32	RT4LD	113738	1	
		10	16	25	40	RT4LE	113739	1	
		12,5	20	32	50	RT4LF	113740	1	
		17	27	50	80	RT4LG	113741	1	
		26	40	80	125	RT4LH	113742	1	
		32	52	100	160	RT4LJ	113743	1	
		45	70	125	160	RT4LK	113744	1	
		60	90	160	200	RT4LL	113745	1	
		80	125	200	250	RT4LM	113746	1	
		CK85	120	190	250	315	RT4LN	113747	1
		CK09	175	280	315	400	RT4LP	113748	1
		CK95 <sup>(2)</sup>	200	310	400	500	RT4LR	113749	1
		CK10	120	190	250	315	RT5LA	113755	1
		CK11	175	280	315	400	RT5LB	113756	1
	CK12 <sup>(3)</sup>	250	400	500	630	RT5LC	113757	1	
		315	500	630	800	RT5LD	113758	1	
		430	700	800	1000	RT5LE	113759	1	
	CK13 <sup>(4)</sup>	500	850	1000	1250	RT6LA	113761	1	

(1) Most suitable fuse in accordance with IEC 60947-4-1.

(2) Fitting direct to the contactor.

(3) Fitting direct to the contactor: by means of a coupling and connection set.

Separate mounting: with screws on DIN rail / with cable connection.

(4) RT6A = RT1 with right setting range plus RTXP, independent mounting base adaptor, to be utilised with current transformer connected by passing cable chosen by customer. Current transformer data on request.

Accessories



Base for separate mounting

			Cat. no.	Ref. no.	Pack
	DIN EN50022-35				
	RT1		RTXP	105170	1
	RT2		RT2XP	113764	1

Setting range cover protection

RT...			RTX3	113762	1
-------	--	--	------	--------	---



Push-button with flexible cable

	for distance RESET				
	RT1... - RT6... (front)	0.5 meters	RTXS	113855	1
	RT1... - RT6... (front)	1 meters	RTXSL	113856	1
	RT1..., RT2..., RT4..., RT5..., RT6... (back)		RTXBS	108864	1

Terminal protection

	for RT3 or CK75C/CK08C				
	Thermal overload relay	1 pole IPxxB	PTPCK75	103747	1
	Connection contactor-relay	3 poles	RT3PXX3P	110565	1



Remote electrical reset

RT1... - RT6...			RTXRR ♦		1
-----------------	--	--	---------	--	---

Available coil voltages (V)

♦	B	D	G	J	N	U	X
AC/DC	12	24	48	110	220	380	440
				240	415	480	

Order codes

Intro

A

B

C

D

E

F

G

H

I

J/X



**Electronic overload relays**

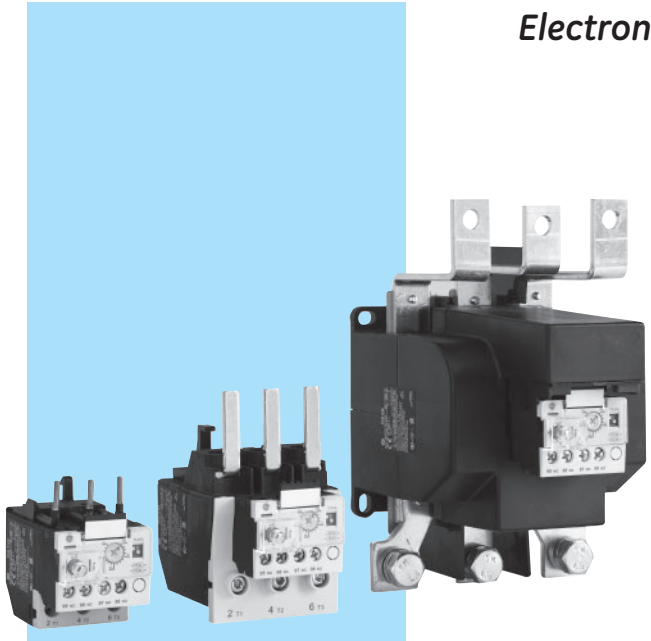

Approvals/Marking



Product features

> Your benefits

Lower power consumption	> Saving space into cabinet
Great accuracy	> Better motor protection
Full reliability	> Low risk to burn motor
Phase unbalance protection	> Better motor protection and current control
Direct fitting to contactors Series CL	> Compact starter
Interchangeable with thermal overload relay	> No need to redesign existing cabinet
Multiple trip class selection	> One device cover for start time motor
Manual / Auto reset	> One device for two solutions

Main characteristics



- Setting range from 0.1 up to 150A
- Self powered
- Thermal memory
- Phase loss protection
- Phase unbalance protection
- Direct fitting to contactors Series CL
- Interchangeable with thermal overload relay
- Multiple trip class selection
- Manual / Auto reset
- Increased flexibility, less order codes, less stock
- Tripp class: 5 - 10 - 20 - 30

Order codes ● pg. A.75  
 Technical data ● pg. A.128  
 Dimensions ● pg. A.130





Electronic overload relays for contactors

	Suitable for	Setting range (A)		Fuses (A) <sup>(1)</sup>	Cat. no.	Ref. no.	Pack.
		Min.	Max.	gL - gG			
 <b>Frame 1</b>	CL00...CL45	0,1	0,5	2	RE1D	101866	5
		0,4	2	4	RE1H	101867	5
		1,0	5	10	RE1K	101868	5
		1,6	8	20	RE1M	101869	5
		6,4	32	63	RE1S	101870	5
		9,0	45	80	RE1W	101871	5
		 <b>Frame 2</b>	CL05...CL10	15	75	125	RE2H
22	110			125	RE2M	101873	1
 <b>Frame 3</b>	CK75-CK08	30	150	250	RE3E	101874	1

Accessories

		Cat. no.	Ref. no.	Pack.
 Transparent cover for pushbutton reset	For frames 1, 2 and 3	RETC	247795	10
pendent mounting base adaptor	Frame 1	RE1XP	247302	1
pendent mounting base adaptor	Frame 2	RE2XP	247303	1

(1) Most suitable fuse in accordance with IEC 60947-4-1, see coordination table on pg. A.128.

Order codes

Intro

A

B

C

D

E

F

G

H

I

J/X





**Intelligent motor management relay  
EntelliPro ES3 / ES5**

- Motor protection and motor control
- Pre-programmed motor typicals
- Communication Interface to Profibus-DP and Modbus RTU system
- Status information from motor and switchgear
- Maintenance information,
- Management of settings and configuration
- Predefined control logic
- Internal event recording with time stamping
- Local control and display devices

**Protection**

- Overload (Class 5 to 40)
- Earth fault (Residual current)
- Phase loss
- Thermistor (PTC)
- Start current
- Blocked rotor
- Under load
- Maximum starts per time
- Self monitoring
- External device monitoring

**Diagnostic**

- Time to overload trip, release
- Number of operations
- Number of motor starts
- Motor ON-time, OFF-time
- Number of overload trips
- Number of thermistor trips
- Maximum currents
- Trip currents

**Drive typicals**

- Direct-on-line
- Reverse
- Star delta
- Star delta reverse
- Softstarter
- Softstarter reverse
- Dahlander
- Pole changing starter
- Solenoid valve
- Actuator

**Approvals/Marking**



**Order information (see page A.77)**

**EntelliPro ES3 DP 2 2**

ES3 = Standard device  
ES5 = Medium device

2 = Power supply and 7 digital inputs, voltage 24V DC  
3 = Power supply and 7 digital inputs, voltage 110-240V AC

0 = no additional 9 digital inputs available  
2 = additional 9 digital input, voltage 24V DC  
3 = additional 9 digital input, voltage 110-240V AC

Order codes ● pg. A.77  
Technical data ● pg. A.78  
Dimensions ● pg. A.80

New



**Intelligent motor management relay**



Type	Voltage	Ref. No.
<b>Standard device (I/O 7 digital inputs / 3 digital outputs)</b>		
EntelliPro ES3 DP 2 0	24V DC	720003
EntelliPro ES3 DP 3 0	240V AC	720004
<b>Mid device (I/O 16 digital inputs / 8 digital outputs + 4-20 mA output)</b>		
EntelliPro ES5 DP 2 2	24V DC / 24V DC	720005
EntelliPro ES5 DP 2 3	24V DC / 240V AC	720006
EntelliPro ES5 DP 3 3	240V AC / 240V AC	720007
<b>Transformer</b>		
EntelliPro CT8	1,4A - 8A	720022
EntelliPro CT32	5,4A - 32A	720023
EntelliPro CT64	10,7A - 64A	720024
EntelliPro CT630	105A - 630A	720025
<b>HMI Control panel</b>		
EntelliPro CP3	HMI 3,3" LCD	720028
EntelliPro CP5	HMI 7" color TFT-LCD	720029
<b>Parameterizing user software</b>		
WinESG V3	EntelliPro software tool for Windows	720020
<b>Demonstration KIT</b>		
Demo-case	Demonstration KIT for EntelliPro	720030

Order codes

Intro

A

B

C

D

E

F

G

H

I

J/X



New

Intelligent motor management relay

Overload tripping curves IEC 60947-4-1 (3-Pole / 3-Wire)

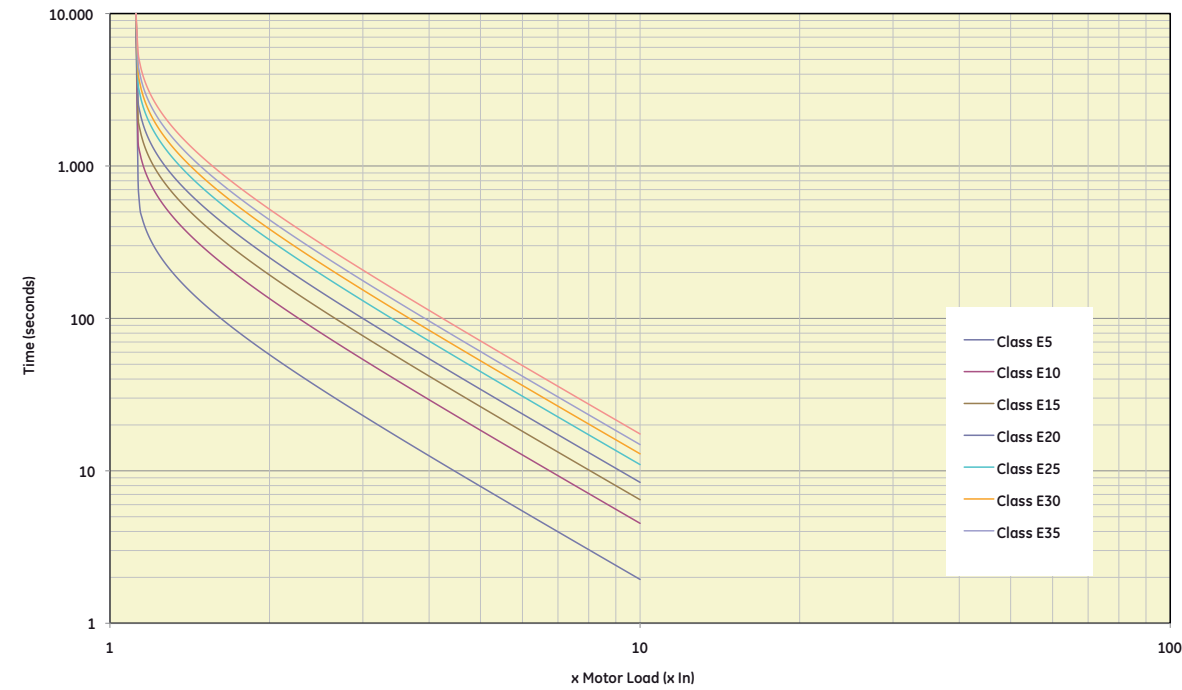

Current (x In)	Class E5 (sec)	Class E10 (sec)	Class E15 (sec)	Class E20 (sec)	Class E25 (sec)	Class E30 (sec)	Class E35 (sec)	Class E40 (sec)	Tolerance (%)
1.2	314.70	734.29	1048.99	1363.68	1783.28	2097.98	2412.67	2832.27	10
1.4	156.93	366.16	523.09	680.01	889.25	1046.17	1203.10	1412.83	10
1.6	103.43	241.33	344.75	448.18	586.08	689.50	792.93	930.83	10
1.8	75.21	175.49	250.70	325.91	426.19	501.40	576.61	676.90	10
2	57.80	134.86	192.66	250.46	327.53	385.33	443.12	520.19	10
2.5	34.41	80.29	114.70	149.11	194.99	229.40	263.81	309.69	10
3	23.26	54.10	77.85	101.91	133.65	155.70	178.76	209.50	10
3.5	16.79	39.02	56.31	73.91	97.03	112.62	129.22	151.34	10
4	12.74	29.56	42.80	56.34	74.06	85.60	98.14	114.86	10
4.5	10.02	23.22	33.74	44.56	58.66	67.48	77.30	90.40	10
5	8.11	18.75	27.36	36.26	47.81	54.71	62.62	73.16	10
5.5	6.71	15.48	22.68	30.19	39.86	45.37	51.87	60.55	10
6	5.65	13.01	19.10	24.31	31.97	37.52	43.16	50.43	10
6.5	4.83	11.10	16.43	20.76	27.33	32.06	36.89	43.06	10
7	4.18	9.59	13.40	17.96	23.67	27.76	31.94	37.25	10
7.2	3.90	9.08	12.78	17.00	22.42	26.28	30.25	35.26	10
8	3.20	7.39	10.40	13.88	18.33	21.47	24.71	28.76	20
9	2.60	5.89	8.40	11.09	14.68	17.18	18.90	22.98	20
10	2.30	5.20	7.40	9.10	12.19	14.13	16.27	18.85	20

Motor management relay

Intro

A

B

C

D

E

F

G

H

I

J/X



New

Overload tripping curves IEC 60947-4-1 (2-Pole / 2-Wire)

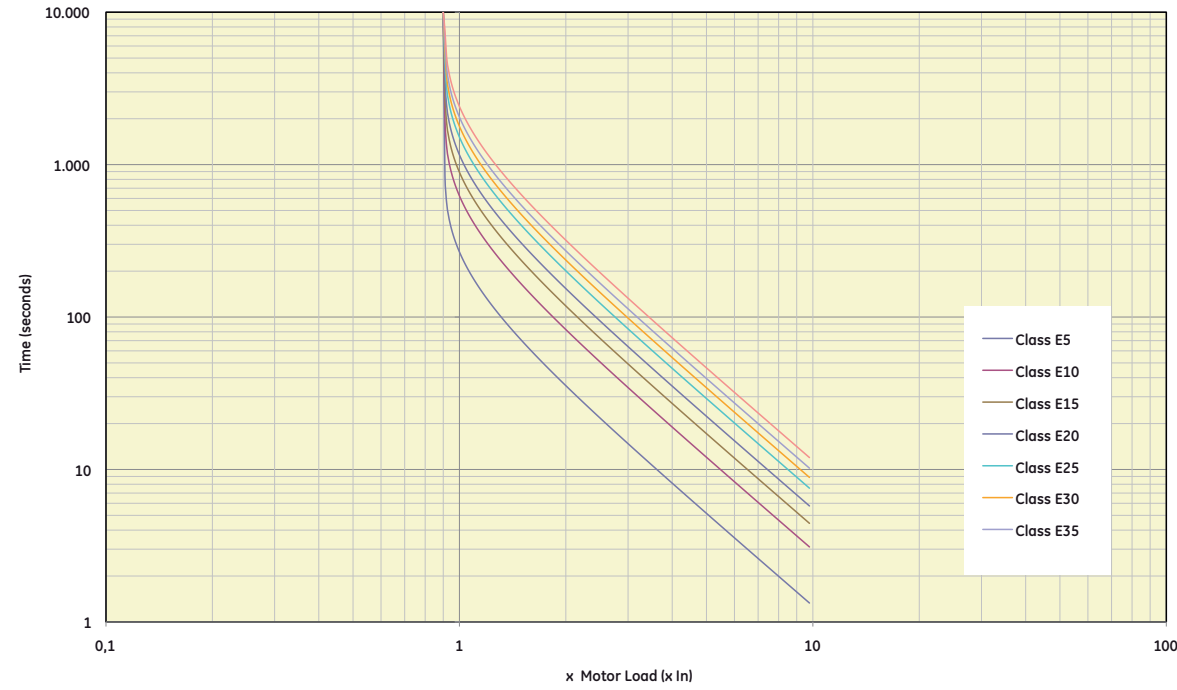

Current (x In)	Class E5 (sec)	Class E10 (sec)	Class E15 (sec)	Class E20 (sec)	Class E25 (sec)	Class E30 (sec)	Class E35 (sec)	Class E40 (sec)	Tolerance (%)
1	267.42	623.99	891.41	1158.83	1515.39	1782.81	2050.24	2406.80	10
1.2	130.59	304.72	435.31	565.91	740.03	870.63	1001.22	1175.35	10
1.4	83.87	195.69	279.56	263.43	475.25	559.12	642.98	754.81	10
1.6	59.72	139.35	199.07	258.79	338.42	398.14	457.88	537.48	10
1.8	45.12	105.27	150.39	195.51	255.67	300.78	345.90	406.06	10
2	35.46	82.75	118.21	153.67	200.96	236.42	271.88	319.17	10
2.5	21.73	50.71	72.45	94.18	123.16	144.90	166.63	195.61	10
3	14.76	34.44	49.20	63.97	83.65	98.41	113.17	132.85	10
3.5	10.70	24.98	35.68	46.39	60.66	71.36	82.07	96.34	10
4	8.13	18.97	27.09	35.22	46.06	54.19	62.32	73.15	10
4.5	6.39	14.90	21.29	27.67	36.19	42.57	48.96	57.48	10
5	5.15	12.02	17.17	22.33	29.20	34.35	39.50	46.37	10
5.5	4.25	9.91	14.15	18.40	24.06	28.30	32.55	38.21	10
6	3.56	8.31	11.86	15.42	20.17	23.73	27.29	32.04	10
6.5	3.03	7.06	10.09	13.12	17.16	20.18	23.21	27.25	10
7	2.80	6.30	8.79	11.70	15.47	17.88	20.94	24.36	10
7.2	2.60	6.05	8.42	11.09	14.66	16.92	19.83	23.07	10
8	2.20	4.90	6.80	9.14	12.09	13.78	16.22	19.04	20
9	1.75	3.80	5.66	7.21	9.61	10.98	13.00	15.05	20
10	1.66	3.50	5.30	6.39	7.87	8.98	12.19	14.01	20

Technical data

Intro

A

B

C

D

E

F

G

H

I

J/X



New

Dimensional drawings

EntelliPro ES3/ES5

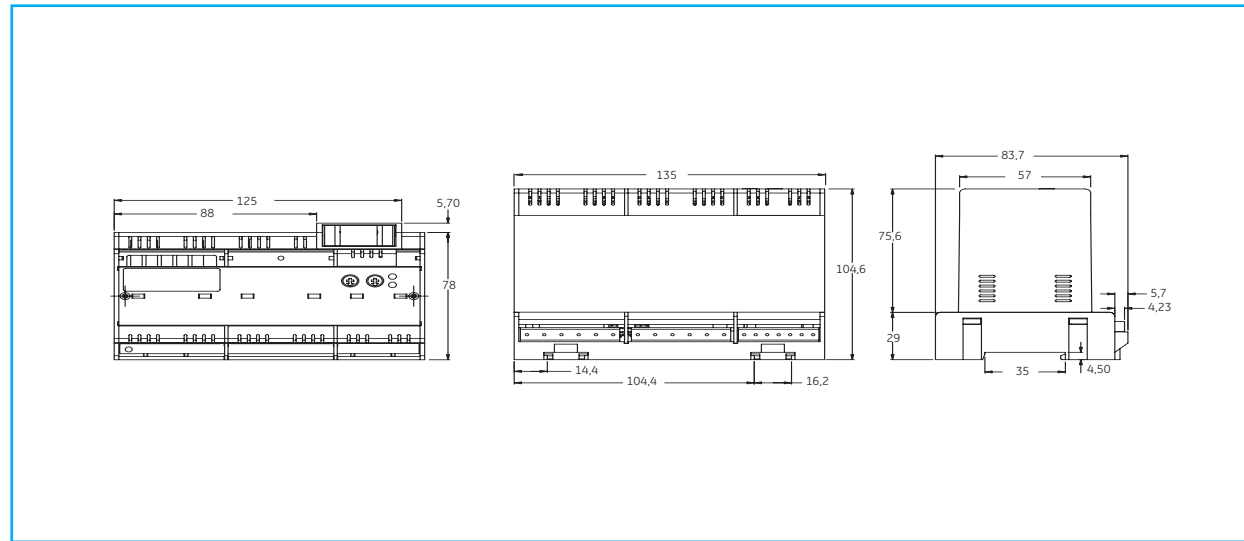

Transformers

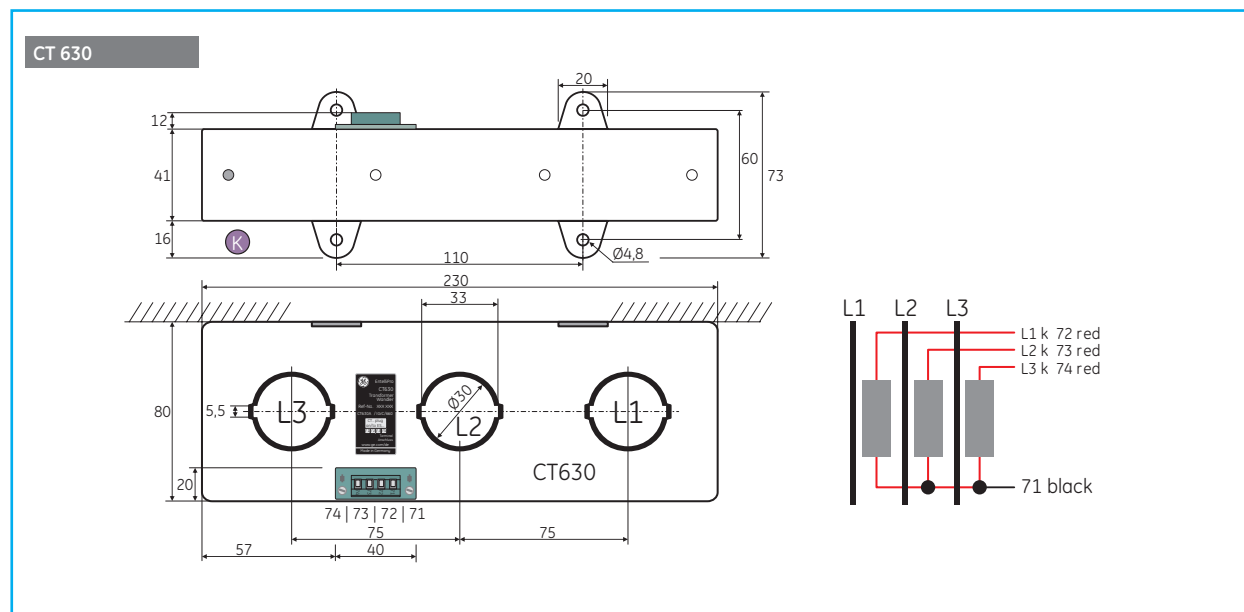
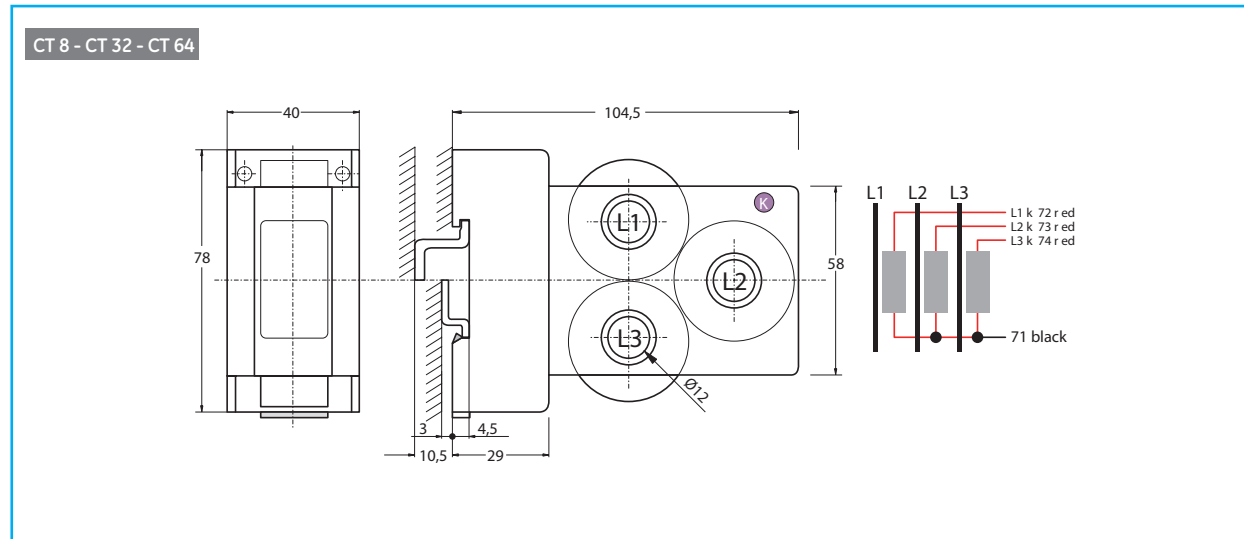

Motor management relay

Intro

A

B

C

D

E

F

G

H

I

J/X



New

Control panel

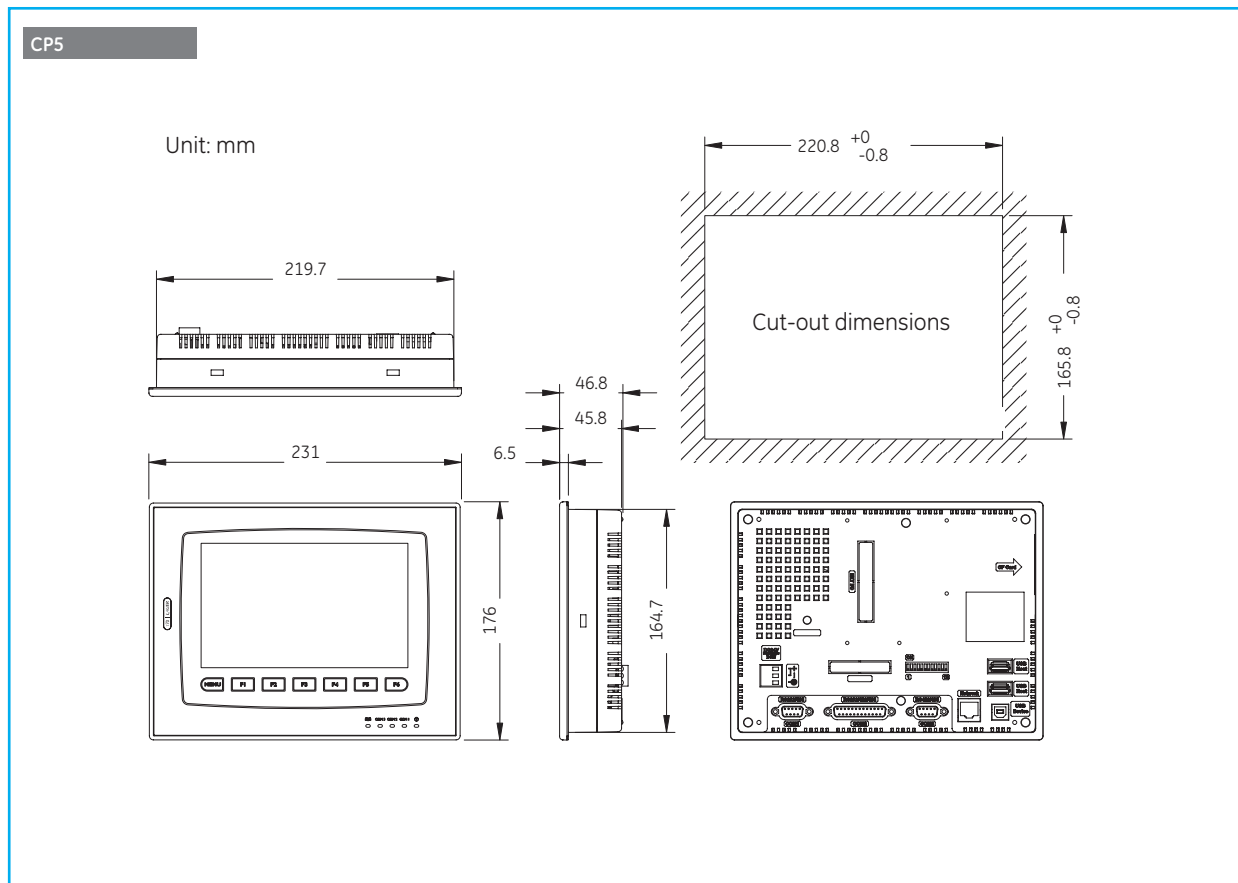
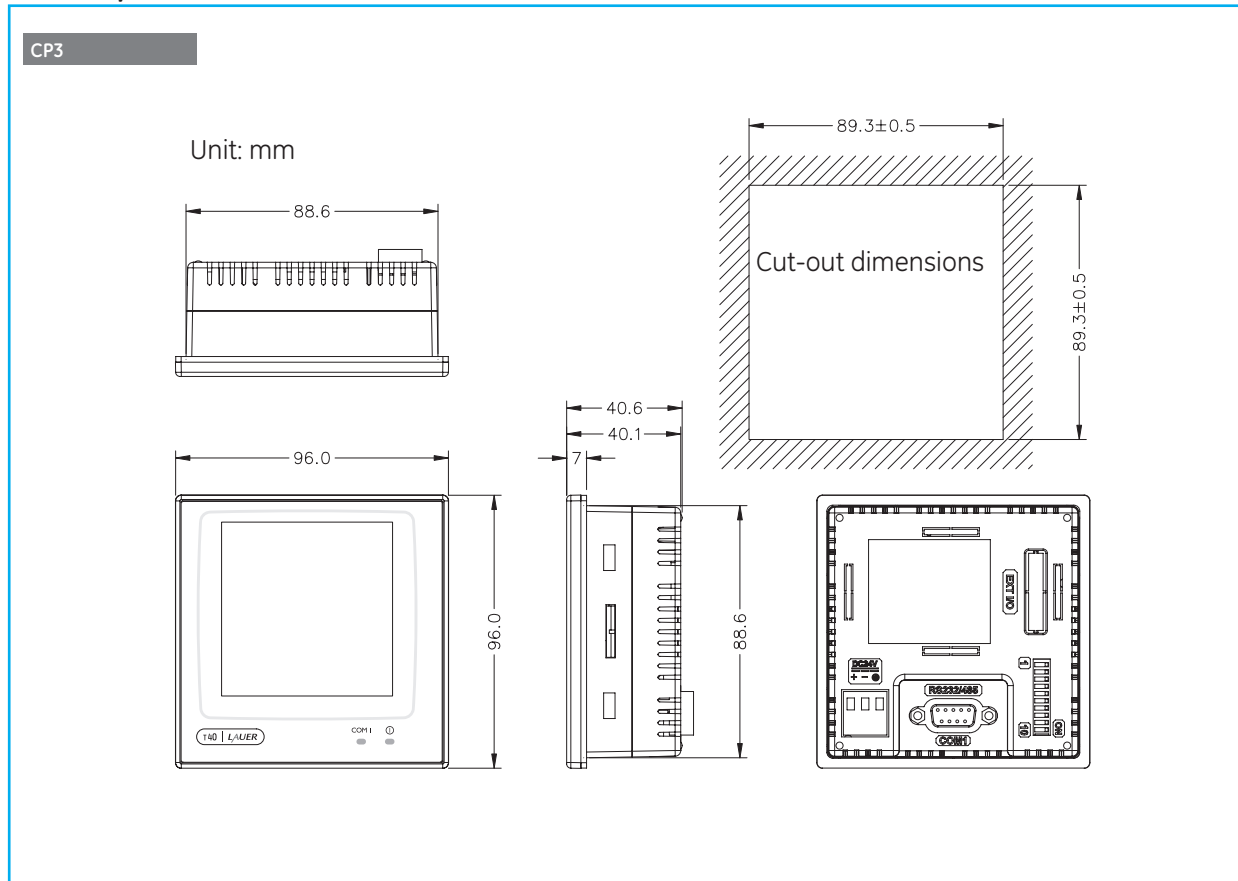

Dimensions

Intro

A

B

C

D

E

F

G

H

I

J/X



New

Notes

Grid area for notes.

Contactors

Intro

A

B

C

D

E

F

G

H

I

J/X





## Technical data

### General

		MC1...	MC2...
Rated thermal current $I_{th} \theta \leq 60^{\circ}C$ (1)	(A)	20	20
Rated operational current $I_e$ (2)	(A)	9	12
(3 x 440V, 50/60Hz, AC-3)			
Maximum number of poles		4	4
Rated insulation current $U_i$	(V)	750	750
Rated operational current $U_e$	(V)	690	690

(1) Insulated terminal type B 2.8 x 0.8 with wire 1 mm<sup>2</sup>:

$I_e = 8A$ , design DIN 46 247

(2) Max.operational current AC3, 3 -phase  $\leq 440V$ , according to IEC 947-4-1

### Conformity to standards

IEC/EN 60947-1	CSA C22.2/14	SEV 10254
IEC/EN 60947-4-1	CENELEC HD 419	JIS C8325
IEC/EN 60947-5-1	VDE 0660	JEM 1038
EN 50003	NFC 63110	NEMA ICS-1
EN 50005	BS 4794	UL 508
EN 50012		

### Approvals

cULus	NEMKO	SEMKO
SETI	DEMKO	RINA
IMQ		
Lloyd's Register	Bureau Veritas	CE

### Ambient conditions

Storage temperature	-55°C to +80°C	
Operation temperature	-40°C to +55°C	
Altitude	up to 3000m	Nominal values
	from 3000 up to 4000m	90% $I_e$ 80% $U_e$
	from 4000 up to 5000m	80% $I_e$ 75% $U_e$

### Climatic resistance

Continuous tests 40 / 125 / 56		
Cold (72h)	Temperature	-40°C
	Temperature	+125°C
	Relative humidity	< 50%
Humid heat (56h)	Temperature	+40°C
	Relative humidity	95%
	Cyclic tests	
First half-cycle (12h)	Low temperature	+25°C
	Relative humidity	93%
	Second half-cycle (12h)	Low temperature
Relative humidity		95%
Number of consecutive cycles		6

### Shock resistance (IEC 68-2-27)

Continuously closed (at 0.8Us)	
Admissible acceleration	25 g
Impulse duration	11 ms
Continuously opened (no voltage)	
Admissible acceleration	20 g
Impulse duration	11 ms

### Vibration resistance (IEC 68-2-6)

Continuously closed (at 0.8Us)	
Admissible acceleration	15 g
Sweep between	10 - 200 Hz
Continuously opened (no voltage)	
Admissible acceleration	5g (AC) - 35g (DC)
Sweep between	10 - 200 Hz

### Mounting positions

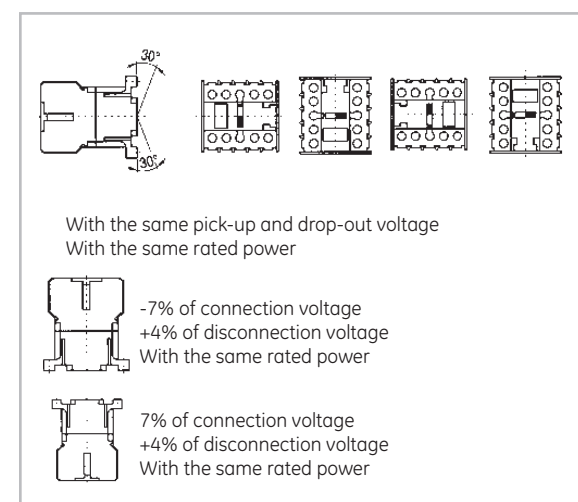

### Terminal capacity

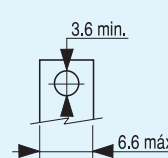
Terminal with M3.5 screw (with pozidrive head and safety flange)	Tightening torque	
	0.8 Nm - 7 Lb/in	
Solid wire	mm <sup>2</sup>	0.75 to 2 x 2 w.
Flexible wire without terminal	mm <sup>2</sup>	0.75 to 2.5 x 2 w.
Flexible wire without terminal with cap	mm <sup>2</sup>	0.75 to 2.5 x 1 w.
	mm <sup>2</sup>	0.75 to 1 x 2 w.
Ring terminal	0.8 Nm - 7 Lb/in	
		
Faston terminal 2.8 - 2 insulated terminals	mm <sup>2</sup>	1 x 2 w.
Terminal for printed circuit (Ø of PCB hole)	1.8 mm	
Ring terminal cap	7.8 mm	
Fork terminal cap	6.5 mm	

Technical data

Intro

A

B

C

D

E

F

G

H

I

J/X



Control circuit

		MC_A...	MC_C...	MC_I...	MC_K...	MC_C...W
Rated insulation voltage (Ui)	(V)	750	750	750	750	750
Standard voltages (Us)						
50Hz(V)		24 ... 690	-	-	-	-
60Hz(V)		6 ... 600	-	-	-	-
DC	(V)	-	6 ... 440	24	24	12 ... 440
Operating voltages limits						
Operating <sup>(1)</sup>	xUs	0.8 ... 1.1	0.8 ... 1.1	0.8 ... 1.25	0.7 ... 1.25	0.7 ... 1.3
Drop-out	xUs	0.35 ... 0.55	0.15 ... 0.4	0.15 ... 0.3	0.15 ... 0.35	0.15 ... 0.3
Operating voltages limits with coil 50/60 Hz						
Operating	xUs	0.8 ... 1.1	-	-	-	-
Drop-out	xUs	0.35 ... 0.55	-	-	-	-
Consumption						
50 or 60Hz - monofrequency coil						
Pick-up	(VA)	26	-	-	-	-
Seal	(VA)	4	-	-	-	-
50/60Hz - bifrequency coil						
Pick-up	(VA)	32	-	-	-	-
Seal	(VA)	6	-	-	-	-
DC	(W)	-	3	1.2	2	4
Power factor						
Magnetic circuit open	(cos φ)	0.8	-	-	-	-
Magnetic circuit closed	(cos φ)	0.35	-	-	-	-
Power dissipation	(W)	1.4	3	1.2	2	4
Opening and closing times						
Values between ± %Us	%	+10 ... -20	+10 ... -20	+25 ... -30	+25 ... -30	+30 ... -30
Time on energisation NO	(ms)	6 ... 13	22 ... 36	30 ... 70	20 ... 50	17 ... 28
Time on de-energisation NC	(ms)	8 ... 16	9 ... 12	9 ... 16	9 ... 16	9 ... 12
Time on energisation NC	(ms)	5 ... 11	18 ... 27	20 ... 45	18 ... 35	12 ... 25
Time on de-energisation NO	(ms)	6 ... 13	5 ... 7	5 ... 9	5 ... 9	5 ... 7
Values at Us						
Time on excitation NO	(ms)	7 ... 12	24 ... 27	25 ... 45	25 ... 40	11 ... 23
Time on desexcitation NC	(ms)	8 ... 16	9 ... 11	9 ... 16	9 ... 16	9 ... 11
Time on excitation NC	(ms)	6 ... 10	20 ... 26	25 ... 35	20 ... 30	15 ... 21
Time on desexcitation NO	(ms)	6 ... 13	5 ... 8	5 ... 9	5 ... 8	5 ... 8
Maximum time without voltage	(ms)	3	3	3	3	3
Mechanical endurance						
Monofrequency coil	10 <sup>6</sup> ops.	>15	-	-	-	-
Bifrequency coil	10 <sup>6</sup> ops.	>10	-	-	-	-
DC	10 <sup>6</sup> ops.	-	10	10	10	10
Maximum rate						
No load	Monofrequency coil	ops./h	9000	-	-	-
	Bifrequency coil	ops./h	3600	-	-	-
	DC	ops./h	-	9000	9000	9000
AC1 and AC3 (at rated power)	ops./h	1200	1200	1200	1200	1200
AC4 (at rated power)	ops./h	300	300	300	300	300

Contactor

Intro

A

B

C

D

E

F

G

H

I

J/X



Main circuit (poles)

		MC1...	MC2...
Rated insulation voltage (Ui) (acc. IEC 947-4)	(V)	750	750
Rated thermal current (Ith) $\theta \leq 60^\circ \text{C}$	(A)	20	20
Frequency limits	(Hz)	0...400	0...400
Making capacity (r.m.s.) $U_e \leq 690\text{V } 50/60\text{Hz}$	(A)	160	160
Breaking capacity (r.m.s.) $U_e \leq 440\text{V}$	(A)	106	106
$U_e = 500\text{V}$	(A)	90	90
$U_e = 690\text{V}$	(A)	80	90
Short-time current			
0.3 sec.	(A)	470	470
1 sec.	(A)	250	250
5 sec.	(A)	125	125
10 sec.	(A)	95	95
30 sec.	(A)	70	70
1 min.	(A)	50	50
3 min.	(A)	40	40
Recovery time	min.	10	10
Protec. against short-circuits (IEC 947-4), w/o TOR			
Coordination type "1" gL/gG	(A)	32	32
Coordination type "2" gL/gG	(A)	20	20
w/o welding contacts gL/gG	(A)	16	16
Circuit breaker rating (curve G CEE 19.1)		20	20
Impedance per pole	(m $\Omega$ )	1.5	1.5
Power dissipation per pole			
AC1	(W)	0.6	0.6
AC3	(W)	0.128	0.228
Insulation resistance			
Between adjacent poles	(m $\Omega$ )	> 10	> 10
Between pole and earth	(m $\Omega$ )	> 10	> 10
Between input and output	(m $\Omega$ )	> 10	> 10
Guaranteed no overlap between NO and NC contacts			
Space	(mm)	1	1
Time	(ms)	> 2	> 2

(1) Insulated terminal type B 2.8 x 0.8 with wire 1 mm<sup>2</sup> I<sub>e</sub> = 8A acc. to DIN 46247

Electrical endurance

Category AC1

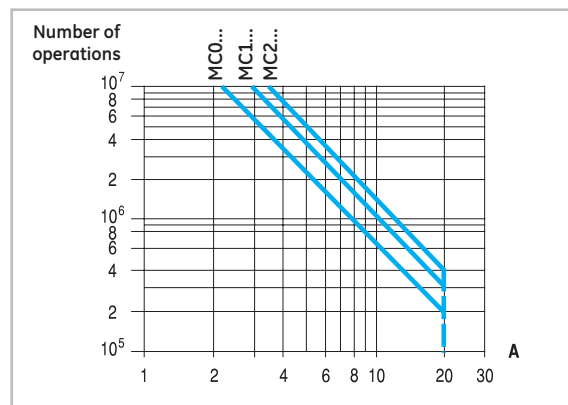

Category AC3

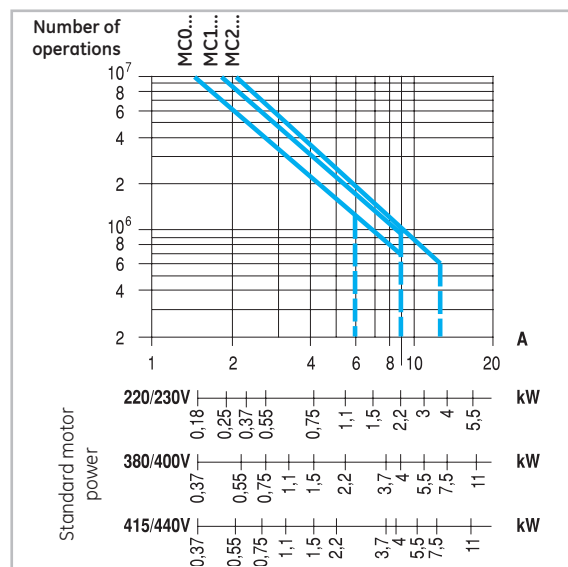

Category AC4

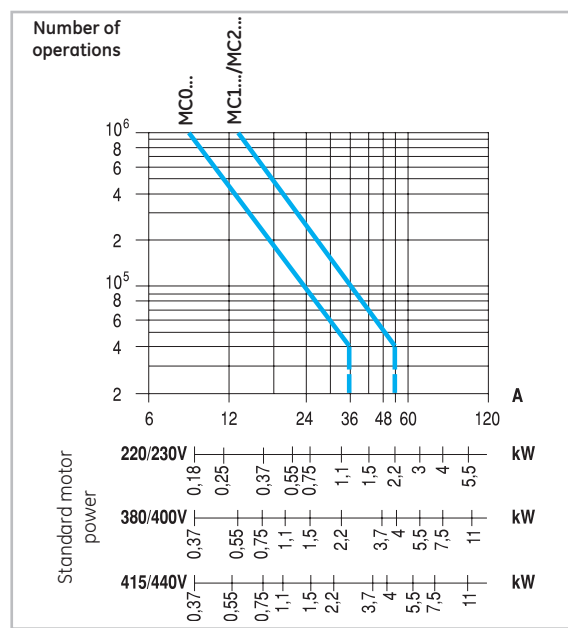

Technical data

Intro

A

B

C

D

E

F

G

H

I

J/X



Internal auxiliary contacts

		MC1 / MC2
Rated insulation voltage (Ui) IEC 60947-5	(V)	750
Rated thermal current (Ith) $\theta \leq 60^\circ\text{C}$ (1)	(A)	16
Making capacity according with IEC 60947-5-1		
Ue $\leq$ 690 50-60 Hz	(A)	160
Ue $\leq$ 440V DC	(A)	160
Breaking capacity (r.m.s.) IEC 60947-5-1		
AC-15		
Ue $\leq$ 440V / 50-60 Hz	(A)	106
DC-13		
Ue $\leq$ 110V DC	(A)	3
Ue = 220V DC	(A)	1.2
Ue = 48V DC	(A)	10
Minimum operational power (operational safety)		5mA, 17V
Short-circuit protection (max.class gl fuse) w/o welding	(A)	10
Insulation resistance		
Between adjacent contacts	(m $\Omega$ )	> 10
Between contacts and earth	(m $\Omega$ )	> 10
Between input and output	(m $\Omega$ )	> 10
Guaranteed no overlap between NO and NC contacts		
Space	(mm)	0,5
Minimal time	(ms)	> 2
Impedance	(m $\Omega$ )	2.3
Terminal capacity		Same as main circuit

(1) Insulated terminal type B 2.8 x 0.8 with wire 1 mm<sup>2</sup> Ie = 8A acc. with DIN 46247

Tripping characteristics (AC)

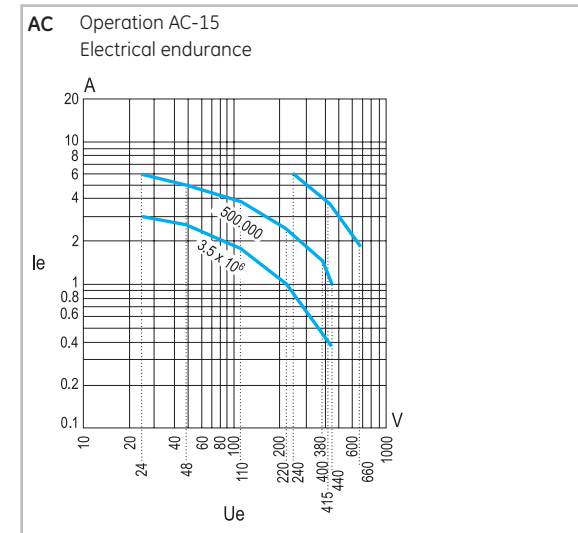

Tripping characteristics (DC)

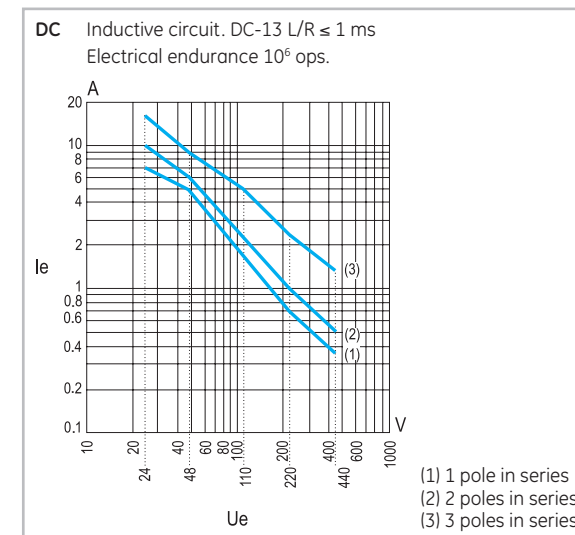
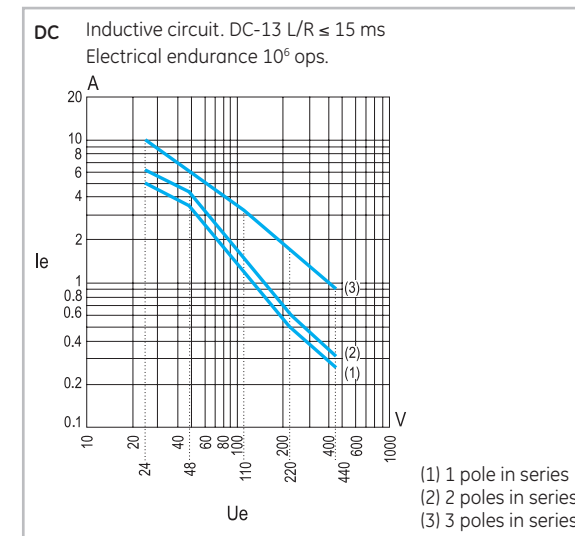
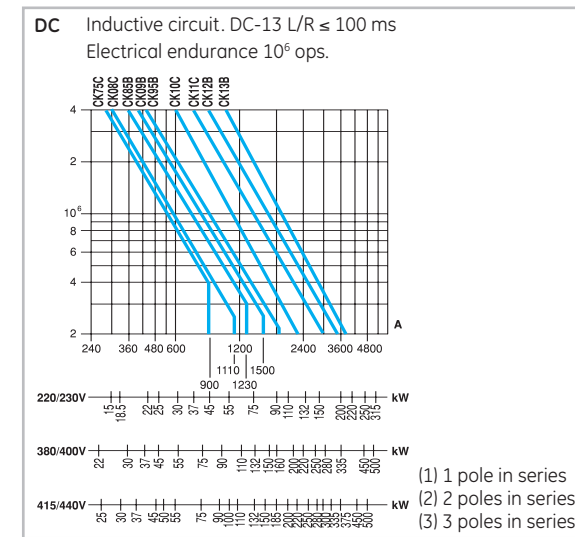

Instantaneous auxiliary contact blocks

		MACN..., MACL...
Rated insulation voltage (Ui) acc. IEC 60947-1	(V)	750
Rated thermal current (Ith) $\theta \leq 60^\circ\text{C}$ (1)	(A)	10
Making capacity (r.m.s.) according with IEC/EN 60947-5-1		
AC-15	Ue $\leq$ 220V 50/60 Hz	(A) 73
	Ue = 380V 50/60 Hz	(A) 38
	Ue = 690V 50/60 Hz	(A) 22
DC-13 L/R=100ms	Ue $\leq$ 100V DC	(A) 2.6
	Ue = 220V DC	(A) 1
	Ue = 440V DC	(A) 0.6
Breaking capacity (r.m.s.) acc. IEC/EN 60947-5-1		
AC-15	Ue $\leq$ 220V 50/60 Hz	(A) 73
	Ue = 380V 50/60 Hz	(A) 38
	Ue = 690V 50/60 Hz	(A) 22
DC-13 LR=100ms	Ue $\leq$ 100V DC	(A) 2
	Ue = 220V DC	(A) 0,8
	Ue = 440V DC	(A) 0.4
Rated voltage and rated current Ue-Ie		
AC-15	according to IEC 60947	
	120V - 6A	
	230V - 6A	
	400V - 4A	
	500V - 1A	
	600V - 1A	
	according to UL, CSA	
	A600	
DC-13	according to IEC 60947	
	24V - 4A	
	48V - 2A	
	110V - 0.7A	
	220V - 0.3A	
	440V - 0.1A	
	according to UL, CSA	
	Q600	
Minimum operational power (operational safety)	5 mA, 17V	
Short-circuit protection (max. class gI fuse) w/o welding	(A)	10
Insulation resistance		
Between adjacent contacts	(m $\Omega$ )	> 10
Between contacts an earth	(m $\Omega$ )	> 10
Between input and output	(m $\Omega$ )	> 10
Guaranteed no overlap between NO and NC contacts		
Space	(mm)	0,5
Minimal time	(ms)	> 2
Impedance	(m $\Omega$ )	2.4
Terminal capacity	Same as main circuit	

(1) Insulated terminal type B 2.8 x 0.8 with wire 1 mm<sup>2</sup> Ie = 8A acc. with DIN 46247

Tripping characteristics (DC)

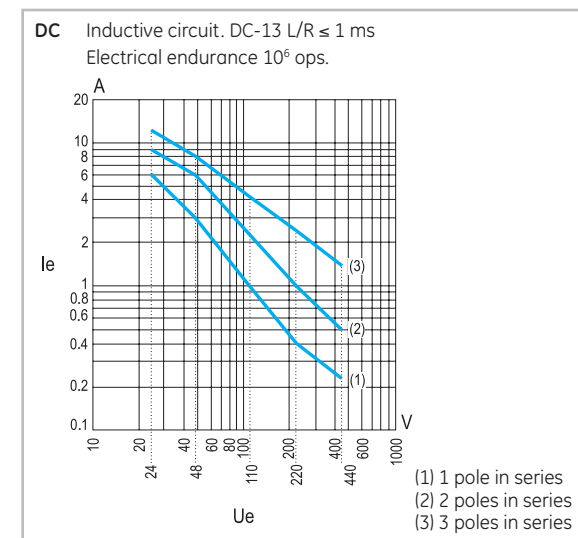
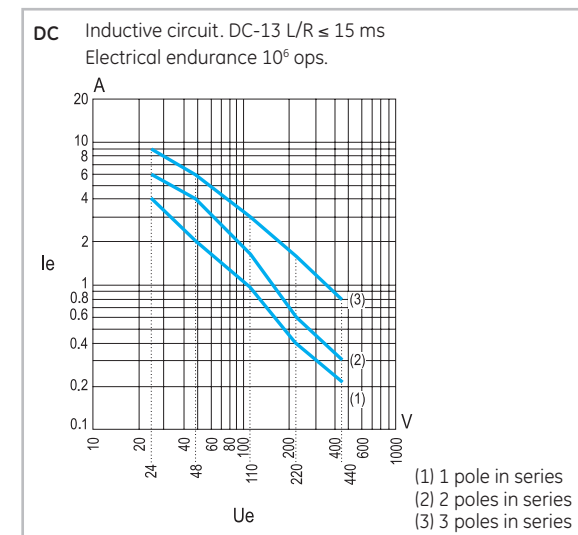
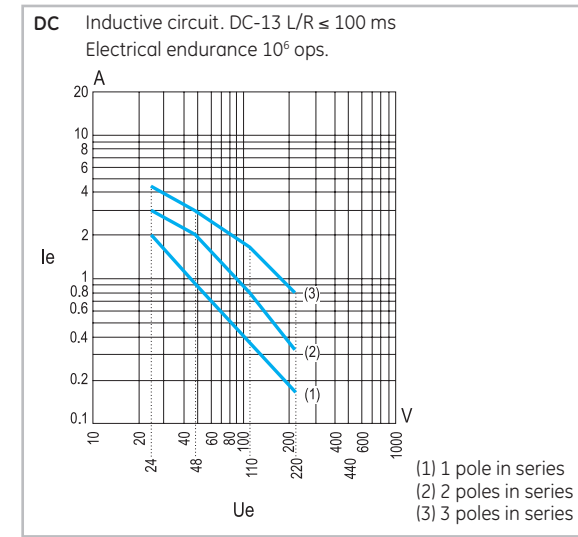

Tripping characteristics (AC)

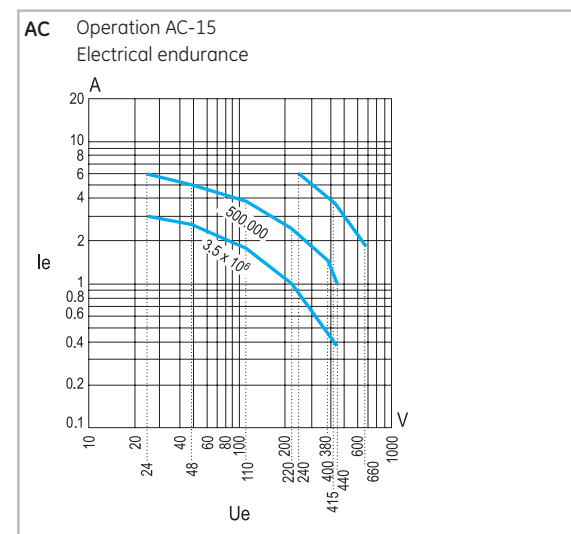

Technical data

Intro

A

B

C

D

E

F

G

H

I

J/X



**Electronic timer block**

		MREBC...
Rated insulation voltage (Ui)	(V)	750
Rated thermal current (Ith) $\theta \leq 60^\circ\text{C}$ [1]	(V)	0.55
Supply voltage (AC and DC)	(V)	24 to 250
Operating limits		0.80 to 1.1 Us (0.85 to 1.1 Us to 12V)
Voltage drop	(V)	< 3
Maximum load current at:		
20°C	(A)	0.9
40°C	(A)	0.72
60°C	(A)	0.55
Minimum load for safe operation	(A)	> 10
Maximum current	(A)	10A per 40 ms
Leakage current at 220V	(mA)	< 5
Operational current		
AC-15	(A)	0.7
DC-13	(A)	0.9
Timing range (delay ON)	(s)	0.5 to 60 ( $\pm 6$ s)
Rearrangement time	(ms)	< 100
Repeatability (accuracy) (%)		$\pm 1$
Ambient temperature		
storage	(°C)	-55 to + 80
operation	(°C)	-5 to + 60
Degree of protection		IP20
Mounting positions		Any
Terminals : 2 free cables		1 mm <sup>2</sup> (AWG 17) 250 mm

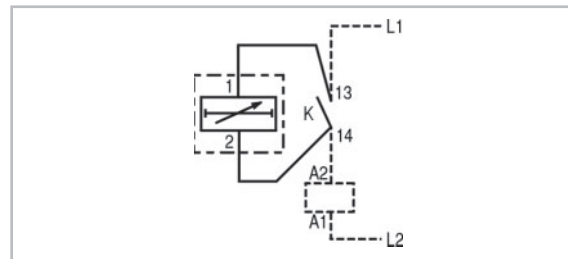

**Contact sequence**

	Main contact (NO)	Main contact (NC)	Auxiliary contact (NO)	Auxiliary contact (NC)
<b>Three-pole minicontactor</b>				
MC...310...	0 2 3.5		0 2.3 3.5	
MC...301...	0 2 3.5			0 1.2 3.5
<b>Four-pole minicontactor</b>				
MC...400...	0 2 3.5			
MC...B00...	0 2 3.5	0 1.2 3.5		
MC...A00...		0 1.2 3.5		
<b>Auxiliary contact block</b>				
MAC...			0 2.1 3.5	0 1 3.5
MAR...			0 2.1 3.5	0 1 3.5



Terminal numbering in accordance with EN 50012

Final structure of the contactor	Auxiliary contactors		Possible basic contactors + Auxiliary contact blocks to be added
	Combination	NO NC	
Without auxiliary contact blocks			
		0 1	MC_A310A...
		1 0	MC_A310A...
Auxiliary contact blocks front mounted with two or four contacts			
		1 1	MC_A310A... + MACN211A
		2 1	MC_A310A... + MACN211A
		1 2	MC_A310A... + MACN202A
		3 1	MC_A310A... + MACN431A
		4 1	MC_A310A... + MACN431A
		2 2	MC_A310A... + MACN422A
		3 2	MC_A310A... + MACN422A
		1 3	MC_A310A... + MACN413A
		2 3	MC_A310A... + MACN413A
Auxiliary contact blocks lateral mounted with one contact			
		1 1	MC_A310A... + MACL101A
		2 1	MC_A310A... + MACL101A + MACL110A
		1 2	MC_A310A... + MACL101A + MACL101A

Technical data

Intro

A

B

C

D

E

F

G

H

I

J/X



**Terminal numbering**

**Basic three-pole contactors. (EN 50012)**

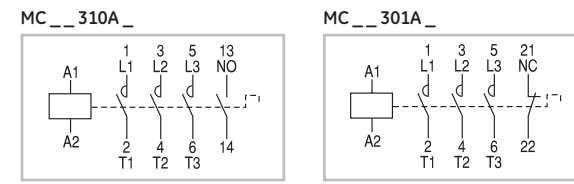

**Instantaneous auxiliary contact blocks. (EN 50012)**

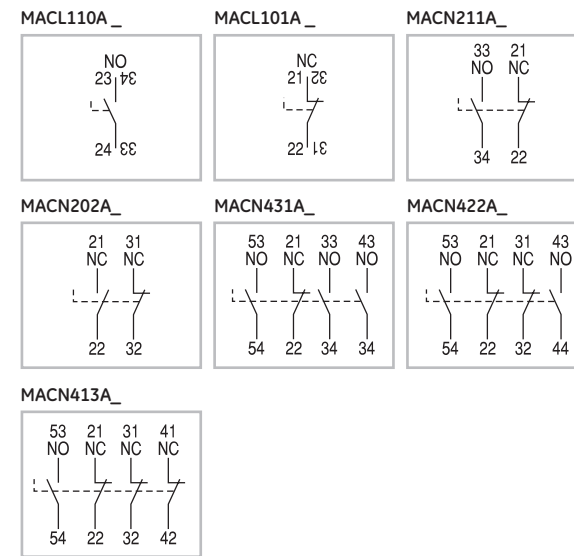

**Instantaneous auxiliary contact blocks. (EN 50005)**

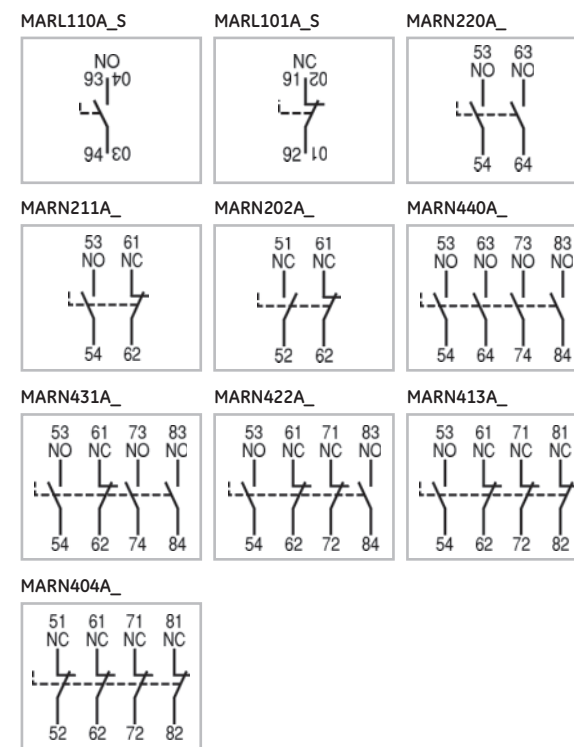

**Base four-pole contactors. (EN 50005)**

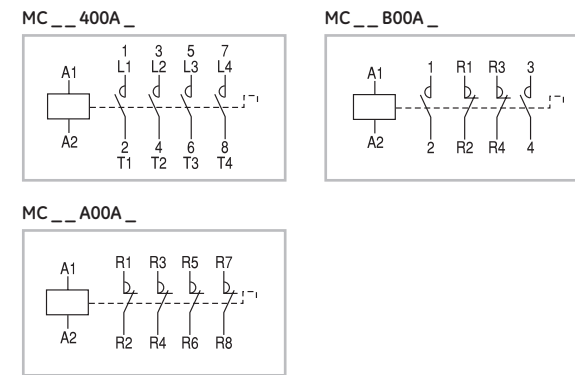

**Instantaneous auxiliary contact blocks. (EN 50005)**

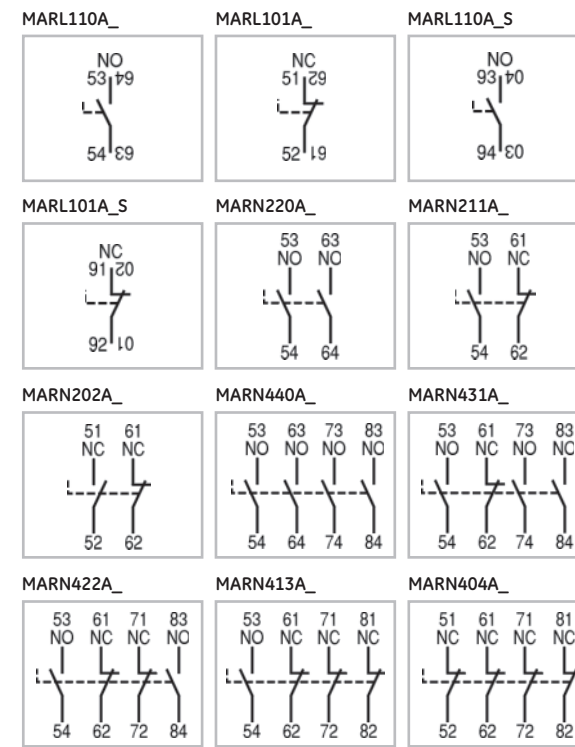

**Voltage suppressor block**

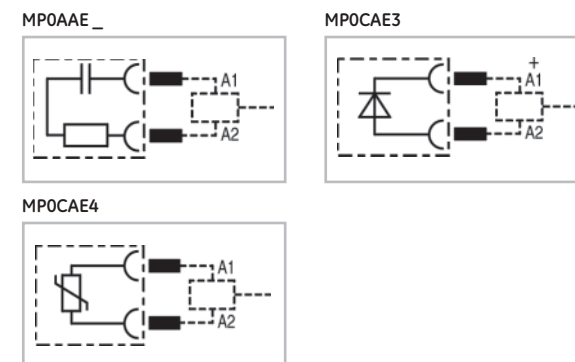



**Conformity to standards**

IEC/EN 60947-1	EN 50005	UNE 20109
IEC/EN 60947-4-1	CENELEC HD419	BS 5424 & 775
IEC/EN 60947-5-1	NF C63-110	NEMA ICS 1
UL 508	ASE 1025	VDE 0660/102
CSA 22.2/14		

**Approvals**

cULus	RINA	CE
SETI	IMQ (up to Ith:32A)	
Lloyd's Register	Bureau Veritas	

**Ambient conditions**

Storage temperature	-55°C to +80°C	
Operation temperature	-40°C to +55°C	
Altitude	up to 3000m	Nominal values
	from 3000 up to 4000m	90%le 80%Ue
	from 4000 up to 5000m	80%le 75%Ue

**Climatic resistance (IEC 68-2)**

Continuous tests 40 / 125 / 56		Cyclic test (6 cycles)	
Cold (72h)		Humid heat	
Temperature	-40°C	First half-cycle (12h)	
Dry heat (96h)		Low temperature +25°C	
Temperature	+125°C	Relative humidity 93%	
Relative humidity	< 50%	Second half-cycle (12h)	
Humid heat (56h)		Low temperature +55°C	
Temperature	+40°C	Relative humidity 95%	
Relative humidity	95%		

**Mounting positions**

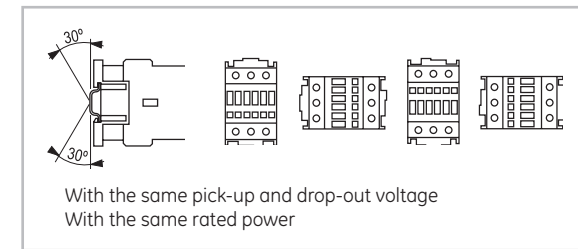

**Terminal capacity and tightening torque**

		CL00 ... CL02	CL25	CL03 ... CL04	CL45	CL05 ... CL08	CL09 ... CL10
	Solid, stranded and finely stranded without end sleeve (mm²)	2 x 0.5 ... 2.5	2 x 0.5 ... 2.5	-	-	-	-
	Finely stranded with or without end sleeve (mm²)	2 x 1 ... 2.5	2 x 1 ... 2.5	-	-	-	-
	AWG wires	2 x 20 ... 12	2 x 20 ... 8	-	-	-	-
	Tightening torque (Nm)	1.6	2.2	-	-	-	-
	(Lb x in.)	15	20	-	-	-	-
	Solid, stranded and finely stranded without end sleeve (mm²)	-	-	0.75 ... 16	0.75 ... 16	1 ... 35	1.5 ... 50
	Finely stranded with end sleeve (mm²)	-	-	0.75 ... 16	0.75 ... 16	1 ... 35	1.5 ... 50
	Finely stranded w/o end sleeve (mm²)	-	-	1 ... 16	1 ... 16	1 ... 35	1.5 ... 50
	AWG wires	-	-	18 ... 6	18 ... 6	16 ... 2	16 ... 2
	Tightening torque (Nm)	-	-	1.4	1.8	4	5.6
(Lb x in.)	-	-	12	16	35	50	
	Solid (mm²)	-	-	0.75 ... 16	0.75 ... 16	1 ... 16	4 ... 35
	Stranded (mm²)	-	-	0.75 ... 16	0.75 ... 16	1 ... 25	4 ... 35
	Finely stranded w/o end sleeve (mm²)	-	-	0.75 ... 16	0.75 ... 16	1 ... 25	4 ... 35
	Finely stranded with end sleeve (mm²)	-	-	1 ... 16	1 ... 16	1 ... 25	4 ... 35
	AWG wires	-	-	18 ... 6	18 ... 6	16 ... 4	10 ... 1
Tightening torque (Nm)	-	-	1.4	1.8	4	5.6	
(Lb x in.)	-	-	12	16	35	50	
	Solid, stranded and finely stranded without end sleeve (mm²)	-	-	Max. 16	Max. 16	Max. 50 ... 4	Max. 50 ... 35
	Finely stranded w/o end sleeve (mm²)	-	-	-	-	Max. 25 ... 16	-
	Finely stranded with end sleeve (mm²)	-	-	-	-	Max. 25 ... 25	-
	AWG wires	-	-	Max. 6	Max. 6	Max. 2 ... 12	Max. 1
	Tightening torque (Nm)	-	-	1.4	1.8	4	5.6
(Lb x in.)	-	-	12	16	35	50	
	Ring terminals (Ø i)	3,6	4,2	4,2	4,2	6,2	6,2
	(acc. with IEC/EN 60947-1) (A)	8	10	10	10	12,5	12,5
	Tightening torque (Nm)	1,6	1,4	1,4	1,4	3	3
	(Lb x in.)	15	12	12	12	26	26

Technical data

Intro

A

B

C

D

E

F

G

H

I

J/X



Power circuit

		CL00	CL01	CL02	CL25	CL03	CL04	CL45	CL05	CL06	CL07	CL08	CL09	CL10
<b>Three pole version</b>														
Rated thermal current I <sub>th</sub> at θ ≤ 55°C (A)		25	25	32	45	45	60	60	-	90	110	110	140	140
Rated operational current I <sub>e</sub> AC-3 (A)		9	12	18	25	25	32	40	-	50	65	80	95	105
Rated operational voltage U <sub>e</sub> (V)		690	690	690	690	690	690	690	-	690	690	690	690	690
<b>Four pole version (4NO and 2NO+2NC)</b>														
Rated thermal current I <sub>th</sub> at θ ≤ 55°C (A)		-	25	32	-	45	60	-	90	-	110	110	140	-
Rated operational voltage U <sub>e</sub> (V)		-	690	690	-	690	690	-	690	-	690	690	690	-
<b>Three and four pole version</b>														
Rated insulation voltage U <sub>i</sub> (V)		1000	1000	1000	1000	1000	1000	1000	1000	1000	1000	1000	1000	1000
Maximum continuous current AC-1 (A)		25	25	32	45	45	60	60	90	90	110	110	140	140
Frequency limits (Hz)		25.400	25.400	25.400	25.400	25.400	25.400	25.400	25.400	25.400	25.400	25.400	25.400	25.400
Making capacity (RMS) (IEC 947) (A)		450	450	450	450	550	550	550	1000	1000	1000	1000	1280	1280
Breaking capacity (RMS) (IEC 947)														
U <sub>e</sub> = 400V (A)		250	250	250	350	450	450	450	920	920	920	920	1050	1050
U <sub>e</sub> = 500V (A)		250	250	250	320	450	450	450	920	920	920	920	1050	1050
U <sub>e</sub> = 690V (A)		130	130	130	170	205	205	205	780	780	780	780	950	950
Short-time current														
1 sec. (A)		455	455	570	630	1010	1010	1265	1580	1580	2530	2530	3300	3300
5 sec. (A)		205	205	254	280	450	450	450	565	710	1130	1130	1485	1485
10 sec. (A)		144	144	180	200	320	320	400	500	500	800	800	1050	1050
30 sec. (A)		85	85	104	115	185	185	230	290	290	460	460	600	600
1 min. (A)		60	60	74	80	130	130	165	205	205	325	325	430	430
3 min. (A)		35	35	46	50	90	90	100	120	120	185	185	250	250
Recovery time (min.)		10	10	10	10	10	10	10	10	10	10	10	10	10
Protec. against short-circuit with fuses without TOR														
Coordination type "1"														
gL/gG (A)		50	50	63	63	100	100	125	200	200	200	200	250	250
Coordination type "2"														
gL-gG (A)		25	35	35	50	63	63	80	100	100	125	125	160	200
Without welding														
gL-gG (A)		10	10	25	35	35	35	50	80	80	100	100	140	160
Impedance per pole (mΩ)		2.35	2.35	2.41	1.65	1.28	1.28	0.95	0.85	0.85	0.86	0.86	0.76	0.76
Power dissipation per pole														
AC-1 (W)		1.47	1.47	2.46	3.34	2.59	4.6	3.42	6.89	6.86	10.40	10.40	14.89	14.89
AC-3 (W)		0.19	0.34	0.78	1.03	0.80	1.31	1.52	1.36	2.12	3.63	5.5	6.86	8.37
Insulation resistance														
Between adjacent poles (mΩ)		>10	>10	>10	>10	>10	>10	>10	>10	>10	>10	>10	>10	>10
Between poles and earth (mΩ)		>10	>10	>10	>10	>10	>10	>10	>10	>10	>10	>10	>10	>10
Between input and output (mΩ)		>10	>10	>10	>10	>10	>10	>10	>10	>10	>10	>10	>10	>10



Control circuit

		CL00 ... CL25	CL03 ... CL45	CL05 ... CL08	CL09 ... CL10
<b>Alternating current</b>					
Rated insulation voltage U <sub>i</sub>	(V)	1000	1000	1000	1000
Standard voltages U <sub>s</sub> 50 Hz	(V)	24...690	24...690	24...690	24...690
Standard voltages U <sub>s</sub> 60 Hz	(V)	24...600	24...600	24...600	24...600
Voltage operating limits monofrequency coils					
Operating	xU <sub>s</sub>	0.8...1.1	0.8...1.1	0.8...1.1	0.8...1.1
Pick-up	xU <sub>s</sub>	0.6...0.8	0.65...0.8	0.65...0.8	0.65...0.8
Seal	xU <sub>s</sub>	0.35...0.55	0.4...0.6	0.4...0.6	0.4...0.6
Voltage operating limits 50/60 Hz coils					
Operating 50 Hz	xU <sub>s</sub>	0.8...1.1	0.8...1.1	0.8...1.1	0.8...1.1
Operating 60 Hz	xU <sub>s</sub>	0.85...1.1	0.85...1.1	0.85...1.1	0.85...1.1
Pick-up 50 Hz	xU <sub>s</sub>	0.5...0.8	0.6...0.8	0.6...0.8	0.6...0.8
Pick-up 60 Hz	xU <sub>s</sub>	0.65...0.85	0.7...0.85	0.7...0.85	0.7...0.85
Seal 50 Hz	xU <sub>s</sub>	0.3...0.55	0.35...0.60	0.35...0.60	0.35...0.60
Seal 60 Hz	xU <sub>s</sub>	0.35...0.65	0.4...0.6	0.4...0.6	0.4...0.6
Consumption monofrequency coils					
Magnetic circuit closed	(VA)	6	9	15.5	15.5
Magnetic circuit opened (VA)		48	88	190	190
Consumption bifrequency coils					
Magnetic circuit closed (50 Hz/60 Hz)	(VA)	6.8 / 5.6	11.4 / 9.5	20 / 16.6	20 / 16.6
Magnetic circuit opened (50 Hz/60 Hz)	(VA)	53 / 44	120 / 100	245 / 204	245 / 204
Thermal power dissipation (50 Hz/60 Hz)	(W)	2.2 / 1.8	3.2 / 2.6	5.2 / 4.3	5.2 / 4.3
Power factor					
Magnetic circuit closed	cos φ	0.33	0.28	0.26	0.26
Magnetic circuit opened	cos φ	0.84	0.73	0.54	0.54
Opening and closing times					
Values between + 10 % U <sub>s</sub> and - 20 % U <sub>s</sub>					
Time on energisation (NO)	(ms)	6...20	7...25	9...35	9...35
Time on de-energisation (NO)	(ms)	6...13	5...25	9...15	9...15
Values at U <sub>s</sub>					
Time on energisation (NO)	(ms)	8...20	10...19	15...30	15...30
Time on de-energisation (NO)	(ms)	6...13	5...25	9...15	9...15
Mechanical endurance					
Monofrequency coils	10 <sup>6</sup> ops.	15	15	15	15
Bifrequency coils (at 50 Hz)	10 <sup>6</sup> ops.	10	10	8	8
Maximum rate					
Monofrequency coils. No load	ops./h	9000	9000	9000	5000
AC-1 at rated power	ops./h	1200	1200	1200	1200
AC-2 at rated power	ops./h	1000	1000	1000	750
AC-3 at rated power	ops./h	1200	1200	1200	600
AC-4 at rated power	ops./h	360	360	200	200
Bifrequency coils. No load	ops./h	3600	3600	3600	3600

		CL00D ... CL25D		Coils with electronic module		Coils with wide voltage range		
		CL00D ... CL25D	CL03D ... CL45D	CL05E ... CL08E	CL09E ... CL10E	CL00D..W ... CL25D..W	CL03D..W ... CL45D..W	CL05D..W ... CL10D..W
<b>Direct current</b>								
Rated insulation voltage U <sub>i</sub>	(V)	1000	1000	1000	1000	1000	1000	1000
Standard voltages U <sub>s</sub>	(V)	12...440	12...440	24...440	24...440	12...440	12...440	12...440
Operating limits								
Operating	xU <sub>s</sub>	0.8...1.1	0.8...1.1	0.8...1.1	0.8...1.1	0.7...1.3	0.7...1.3	0.7...1.3
Pick-up	xU <sub>s</sub>	0.45...0.65	0.45...0.65	0.70...0.80	0.70...0.80	0.45...0.55	0.45...0.55	0.45...0.55
Drop-out	xU <sub>s</sub>	0.15...0.3	0.15...0.3	0.4...0.6	0.4...0.6	0.15...0.3	0.15...0.3	0.15...0.3
Consumption								
Magnetic circuit closed	(W)	5.5	8	10	10	6.5	10.4	20
Magnetic circuit opened (W)		5.5	8	170	170	6.5	10.4	20
Opening and closing times								
Values between + 10 % U <sub>s</sub> and - 20 % U <sub>s</sub>								
Time on energisation (NO)	(ms)	35...65	35...70	60...80	60...80	26...55	30...65	64...133
Time on de-energisation (NO)	(ms)	6...15	40...65	40...50	40...50	6...15	5...10	20...23
Values at U <sub>s</sub>								
Time on energisation (NO)	(ms)	35...45	40...55	50...60	50...60	35...45	40...55	75...95
Time on de-energisation (NO)	(ms)	7...12	30...65	55...60	55...60	7...12	6...8	20...22
Mechanical endurance	10 <sup>6</sup> ops.	15	15	12	12	15	15	12
Maximum rate								
No load	ops./h	3600	3600	2500	2500	3600	3600	3600
AC1 and AC3 at rated power	ops./h	1200	1200	1200	600	1200	1200	1200
AC4 at rated power	ops./h	360	360	200	200	360	360	200

Technical data

Intro

A

B

C

D

E

F

G

H

I

J/X



**Electrical endurance**

*Mixed category AC4 / AC3*

Electrical endurance for mixed category (AC-3/AC-4) is calculated with the following formula:

$$\text{Electrical endurance (AC-3/AC-4)} = \frac{\text{Electrical endurance (AC-3)}}{1 + \frac{\% \text{ oper AC-4}}{100} \times \left( \frac{\text{Elec.endur. (AC-3)}}{\text{Elec.endur.(AC-4)}} - 1 \right)}$$

*Category AC1*

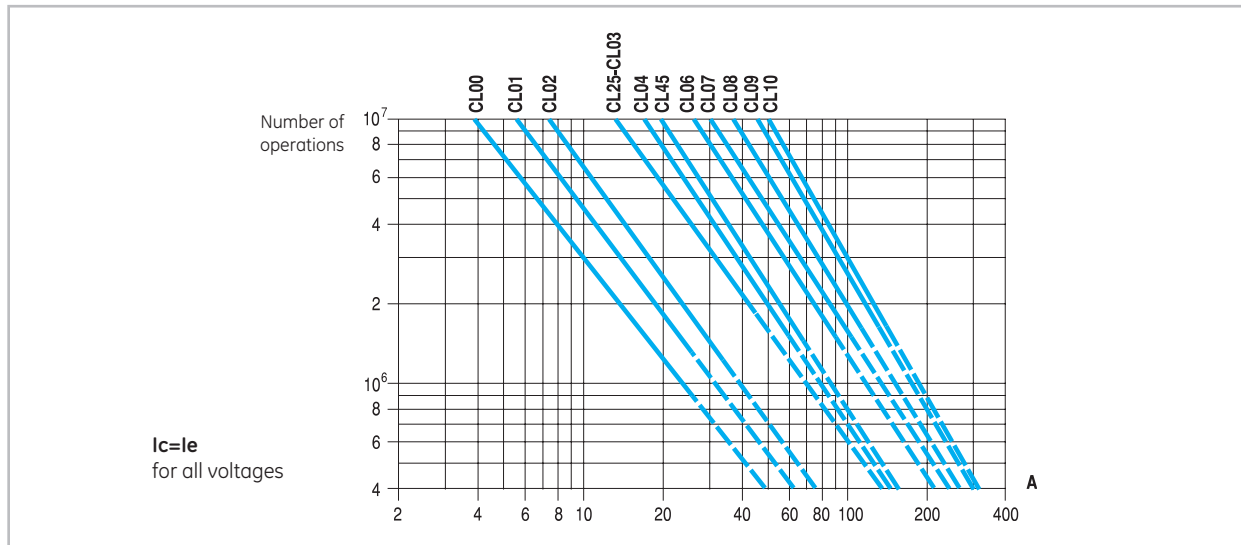

*Category AC2*

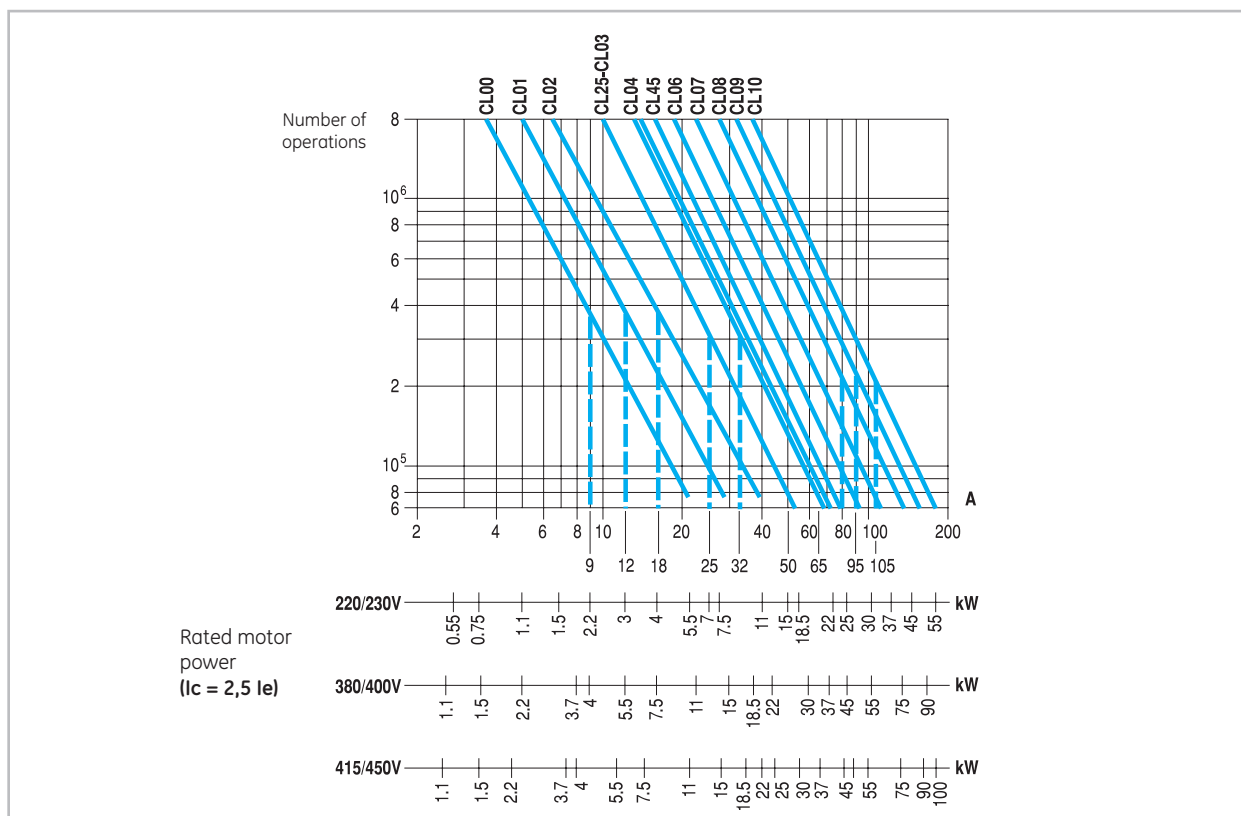

- Contactors
- Intro
- A
- B
- C
- D
- E
- F
- G
- H
- I
- J/X



Category AC3

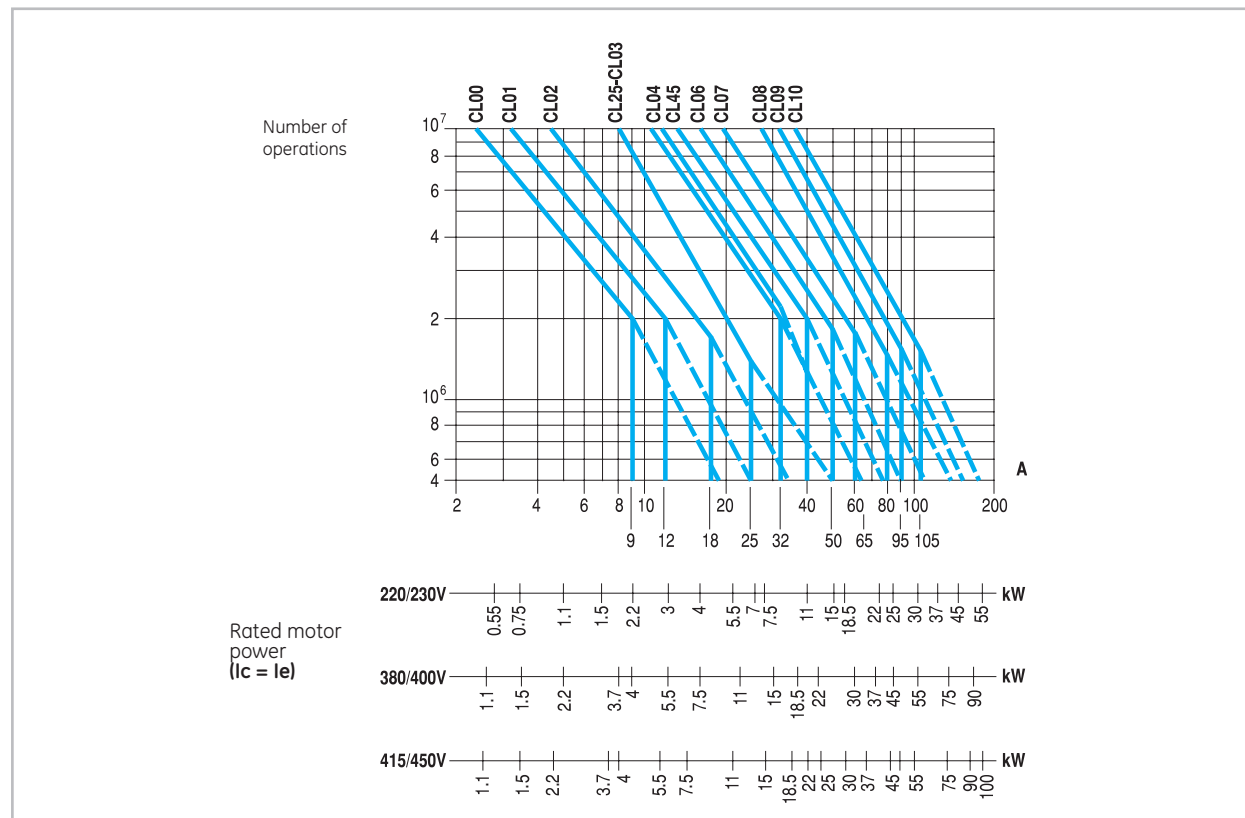

Category AC4

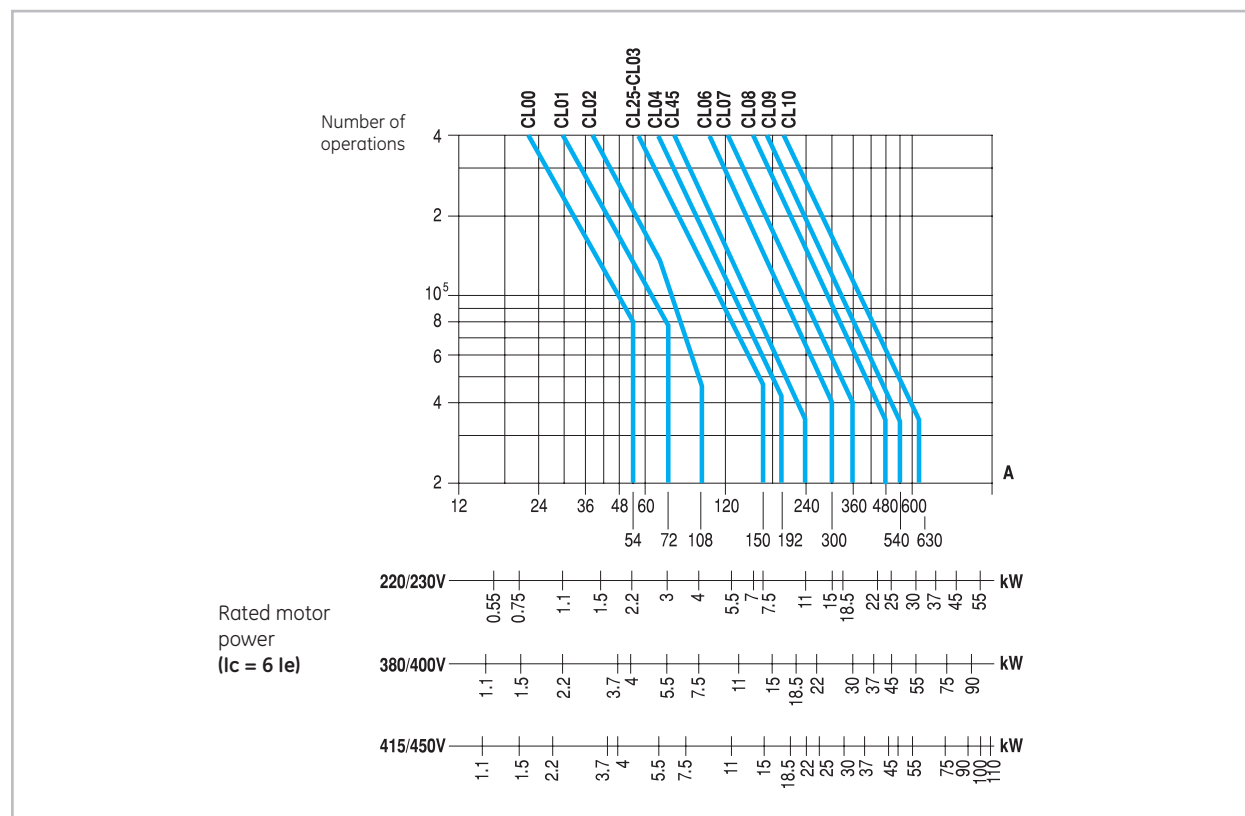

Technical data

Intro

A

B

C

D

E

F

G

H

I

J/X



**Internal auxiliary contacts**

		CL00 ... CL02	CL03 ... CL04
Rated insulation voltage $U_i$ according to IEC 60947	(V)	1000	1000
Rated thermal current $I_{th}$ at $\theta \leq 55^\circ\text{C}$	(A)	20	20
Making capacity (r.m.s.) acc. to IEC 60947			
AC-15	$U_e \leq 400\text{V}, 50/60\text{ Hz}$	(A)	250
DC-13	$U_e \leq 220\text{V DC}$	(A)	250
Breaking capacity (r.m.s.) acc. to IEC 60947			
AC-15	$U_e \leq 400\text{V}, 50/60\text{ Hz}$	(A)	250
DC-13	$U_e \leq 220\text{V DC}$	(A)	2
AC-15	Rated voltage and current $U_e$ - $I_e$	according to IEC	110/120V-10A 220/230V-10A 400/380V-6A 415/450V-5A 500V-4A 690/660V-2A
		according to UL, CSA	A600
DC-13	Rated voltage and current $U_e$ - $I_e$	according to IEC	24V-6A 48V-4A 110V-2A 220V-0.7A 440V-0.35A
		according to CSA	P600
Electrical endurance	ops.	$10^6$	$10^6$
Minimum operational power (operational safety)		17V - 5mA	17V - 5mA
Short-circuit protect.	Max.fuse class gI-gG without welding	(A)	10
Insulation	Between contacts	( $m\Omega$ )	> 10
resistance	Between contacts and earth	( $m\Omega$ )	> 10
	Between input and output	( $m\Omega$ )	> 10
Guaranteed no overlap between NO and NC contacts			
	Space	(mm)	1.3
	Time	(ms)	1.5
Impedance of the contacts		( $m\Omega$ )	1.28

**Auxiliary contact blocks**

		Instantaneous BCLF..., BCRF..., BCLL..., BRLL...	Timed blocks BTLF..., BTRF...
Rated insulation voltage $U_i$ according to IEC 60947	(V)	1000	1000
Rated thermal current $I_{th}$ at $\theta \leq 55^\circ\text{C}$	(A)	10	10
Making capacity (Ieff) according to IEC 60947			
AC-15	$U_e \leq 400\text{V}, 50/60\text{ Hz}$	(A)	90
DC-13	$U_e \leq 220\text{V DC}$	(A)	90
Breaking capacity (Ieff) according to IEC 60947			
AC-15	$U_e \leq 400\text{V}, 50/60\text{ Hz}$	(A)	60
DC-13	$U_e \leq 220\text{V DC}$	(A)	0.95
AC-15	Rated voltage and current $U_e$ - $I_e$	according to IEC	120/110V-6A 230/220V-6A 400/380V-4A 440/415V-3.5A 500V-2.5A 690/660V-1.5A
		according to UL, CSA	A600
DC-13	Rated voltage and current $U_e$ - $I_e$	according to IEC	24V-4A 48V-2A 110V-0.7A 220V-0.3A 440V-0.15A
		according to UL, CSA	Q600
Electrical endurance	$10^6$ ops.	1	1
Mechanical endurance	$10^6$ ops.	10	5
Minimum operational current (operational safety)		17V - 5mA	17V - 5mA
Short-circuit protect.	Max.fuse class gI-gG without welding	(A)	10
Insulation	Between contacts	( $m\Omega$ )	> 10
resistance	Between contacts and earth	( $m\Omega$ )	> 10
	Between input and output	( $m\Omega$ )	> 10
Guaranted no overlap between NO and NC contacts			
	Space	(mm)	1.3
	Time	(ms)	5
Impedance of the contacts		( $m\Omega$ )	1.28
Timing (ambient temperature between $-25^\circ\text{C}$ and $+55^\circ\text{C}$ )			
	Accuracy	-	$\pm 5\%$
	Loss of accuracy $0.5 \times 10^6$ ops.	-	+ 20%
	Loss of accuracy per rise $^\circ\text{C}$ (0 - $55^\circ\text{C}$ )	-	+ 0.75% per $^\circ\text{C}$





**Mechanical latch blocks**

	RMLF...	
Rated insulation voltage Ui	1000 V	
Standard voltages Us : 50 to 60 Hz and DC	24...690 V	
Operating limits	0.75...1.1 xUs	
Consumption for unlatching (auto cut-out)		
24 to 72 V	210 W / VA	
110 to 440 V	130 W / VA	
Electrical unlatching control <sup>(1)</sup>		
Minimum impulse	10 ms	
Maintained	auto cut-out by integral contact	
Manual unlatching control	by local push-button	
Electrical making control		
Minimum pulse	40 ms auto cut-out by integral contact	
Manual making control	by local push-button	
Auxiliary contact NC		
Utilisation AC-15 according to IEC	120V - 6A 230V/220V - 4A 400V/380V - 2.5A	500V - 1.5A 690V/660V - 1A
according to UL/CSA	A600	
Utilisation DC-13 according to IEC	24V - 3A 48V - 1.5A 110V - 0.6A	220V - 0.3A 400V - 0.15A
according to UL/CSA	Q600	
Mechanical endurance		
CL00...CL45	3 million (1200 ops./h)	
CL05...CL10	0.1 million (300 ops./h)	
Wiring diagram Alternating current		
Alternating current / Direct current		

(1) The contactor coil and the unlatch control must not be energised simultaneously

**Terminal capacity**

	Terminal: screw BCLF, BCLL, BTLF y RMLF	Terminal: ring terminal BCRF, BTRF
Solid	2 x 0.5 to 2.5 or 1 x 4	
Stranded and finely stranded without end sleeve	2 x 0.5 to 2.5 or 1 x 4	
Finely stranded with end sleeve	2 x 0.5 to 2.5 or 1 x 4	
AWG wires, solid and stranded	12 - 22 AWG 75°C	
Tightening torque	1.1 Nm / 10 Lb x in.	
	Ring terminal	Ø i A Tightening torque
		3.6 min. 6.5 max. 0.8 Nm / 7 Lb x in.

Technical data

Intro

A

B

C

D

E

F

G

H

I

J/X



Contact sequence

	Basic contactor	Auxiliary contact blocks Front mounted		Auxiliary contact blocks Lateral mounted		
		BCLF 10 BCRF 10	BCLF 01 BCRF 01	BCLL 20 BRLL 20	BCLL 11 BRLL 11	
<b>Three pole contactors 3 NO</b>	CL00... CL01... CL02...	0 3.3 4.7	0 3.2 4.7	0 1.4 4.7	0 3.2 4.7	
	CL25...	0 3 5.1	0 3.7 5.1	0 1.6 5.1	0 3.7 5.1	
	CL03... CL04...	0 4 5.6	0 3.7 5.6	0 1.6 5.6	0 3.7 5.6	
	CL45...	0 4.3 6.5	0 3.7 6.5	0 1.6 6.5	0 3.7 6.5	
	CL06...	0 5.4 8	0 3.7 8	0 1.6 8	0 3.7 8	
	CL07... CL08...	0 4.8 8	0 3.7 8	0 1.6 8	0 3.7 8	
	CL09...	0 5.6 8	0 3.7 8	0 1.6 8	0 3.7 8	
	CL10...	0 5.6 8	0 3.7 8	0 1.6 8	0 3.7 8	
	<b>Four pole contactors 4 NO</b>	CL01... CL02...	0 3.3 4.7	0 3.2 4.7	0 1.4 4.7	0 3.2 4.7
		CL03... CL04...	0 4 5.6	0 3.7 5.6	0 1.6 5.1	0 3.7 5.6
CL05...		0 5.4 8	0 3.7 8	0 1.6 8	0 3.7 8	
CL07...		0 4.8 8	0 3.7 8	0 1.6 8	0 3.7 8	
CL09...		0 5.6 8	0 3.7 8	0 1.6 8	0 3.7 8	
<b>Four pole contactors 2 NO + 2 NC</b>		CL01... CL02...	0 3.3 4.7 1.6	0 3.2 4.7	0 1.4 4.7	0 3.2 4.7 1.4
	CL03... CL04...	0 4 5.6 1.5	0 3.7 5.6	0 1.6 5.1	0 3.7 5.6 1.6	
	CL05...	0 5.4 8 3.7	0 3.7 8	0 1.6 8	0 3.7 8 1.6	
	CL07... CL08...	0 4.8 8 4.3	0 3.7 8	0 1.6 8	0 3.7 8 1.6	

- Contactors
- Intro
- A
- B
- C
- D
- E
- F
- G
- H
- I
- J/X





## Terminal numbering

### Three-pole and four-pole AC contactors

CL00A310 ... CL10A300\_\_  
 CL25D300 ... CL45D300\_\_  
 CL06E300 ... CL10E300\_\_

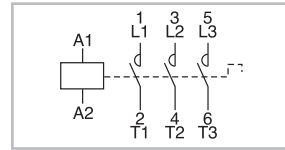

CL00\_310 ... CL02\_310\_\_  
 CL03\_310 ... CL04\_310\_\_

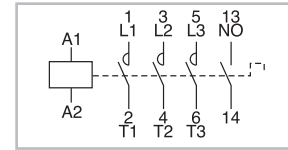

CL00\_301 ... CL02\_301\_\_  
 CL03\_301 ... CL04\_301\_\_

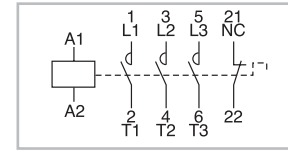

CL45A311 ... CL10A311\_\_

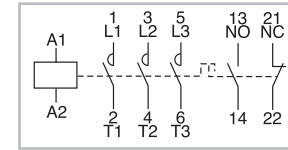

CL25\_310\_\_

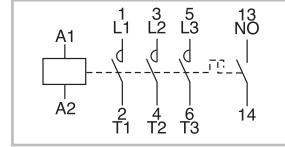

CL25\_301\_\_

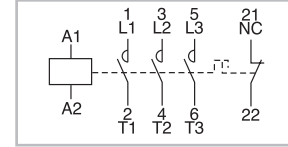

CL00A400 ... CL08A400\_\_  
 CL01D400 ... CL04D400\_\_  
 CL05E400 ... CL09E400\_\_

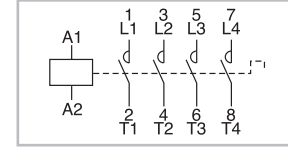

CL01AB00 ... CL08AB00\_\_  
 CL01DB00 ... CL04DB00\_\_  
 CL05EB00 ... CL08EB00\_\_

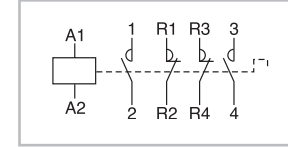

### Auxiliary contact blocks. Front mounting

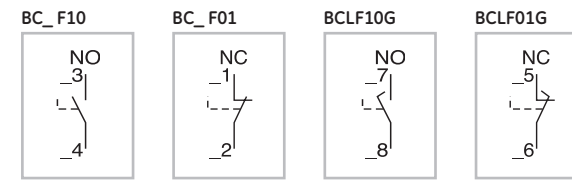

### Auxiliary contact blocks. Lateral mounting

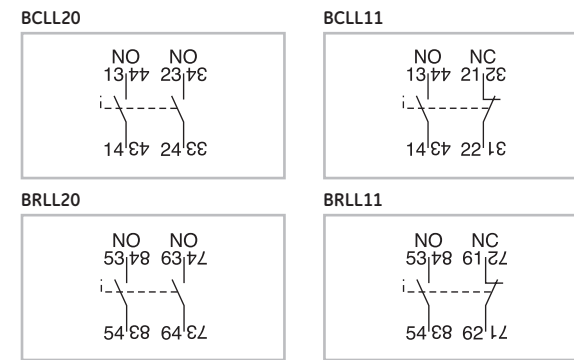

### Pneumatic timer blocks

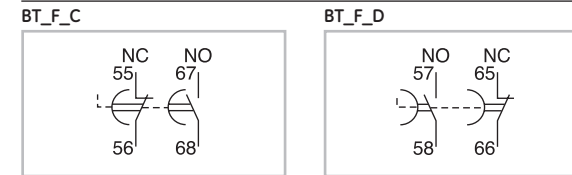

### Electronic timer blocks

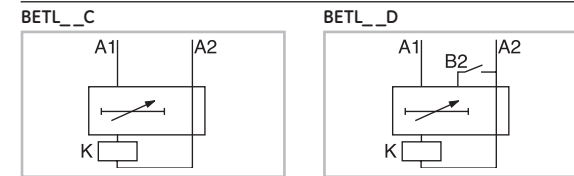

### Mechanical and mechanical/electrical interlock

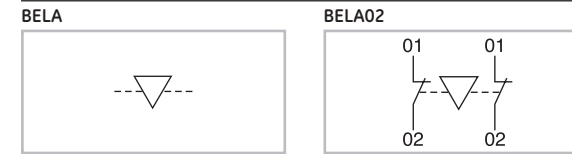

### Voltage suppressor blocks

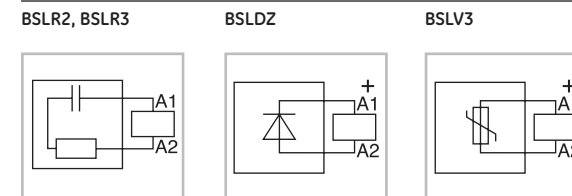

### Mechanical latch block

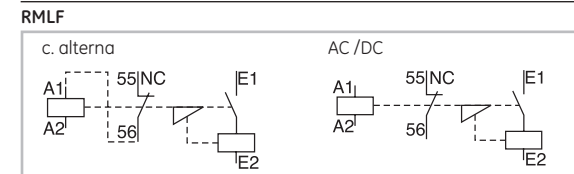

Technical data

Intro

A

B

C

D

E

F

G

H

I

J/X

Terminal numbering according to EN 50012

		Auxiliary contacts		Possible basic contactors + Auxiliary contacts blocks to be added	
		Combination			
		Description	NO	NC	
<b>Without auxiliary contact blocks</b>					
	10E	1	0		CL00_310... - CL04_310...
	01E	0	1		CL00_301... - CL04_301...
<b>Front mounting auxiliary contact blocks with one contact each</b>					
	11E	1	1		CL00_310... - CL04_310... + BC_F01
	21E	2	1		CL00_310... - CL04_310... + BC_F01 + BC_F10
	12E	1	2		CL00_310... - CL04_310... + BC_F01 + BC_F10
	31E	3	1		CL00_310... - CL04_310... + BC_F01 + BC_F10 + BC_F10
	41E	4	1		CL00_310... - CL04_310... + BC_F01 + BC_F10 + BC_F10 + BC_F10
	22E	2	2		CL00_310... - CL04_310... + BC_F01 + BC_F01 + BC_F10
	32E	3	2		CL00_310... - CL04_310... + BC_F01 + BC_F01 + BC_F10 + BC_F10
	13E	1	3		CL00_310... - CL04_310... + BC_F01 + BC_F01 + BC_F01
	23E	2	3		CL00_310... - CL04_310... + BC_F01 + BC_F01 + BC_F01 + BC_F10
<b>Lateral mounting auxiliary contact blocks with two contacts each</b>					
	11E	1	1		CL25_300... - CL45_300... + BCLL11
	31E	3	1		CL25_300... - CL45_300... + BCLL11 + BCLL20
	22E	2	2		CL00_310... - CL45_310... + BCLL11 + BCLL11

The maximum number of auxiliary contacts is 4 for CL00 to CL25, 6 for CL03 -CL04 and 8 for CL45, CL06 to CL10. When using the pneumatic BTLF-block, these numbers are reduced to two, resp. four. ( 2 for CL00 to CL25, 4 for CL03 and CL04, etc.)



Terminal numbering according to EN 50012 (continued)

Diagram	Auxiliary contacts		Possible basic contactors	
	Combination	Description	+ Auxiliary contacts blocks to be added	
	NO	NC		
<b>Without auxiliary contact blocks</b>				
			CL25_300... - CL45_300...	CL06_300... - CL10_300...
<b>Front mounting auxiliary contact blocks with one contact each</b>				
	10E	1 0	CL25_300... - CL45_300... + BC_F10	CL06_300... - CL10_300... + BC_F10
	01E	0 1	CL25_300... - CL45_300... + BC_F01	CL06_300... - CL10_300... + BC_F01
	11E	1 1	CL25_300... - CL45_300... + BC_F10 + BC_F01	CL06_300... - CL10_300... + BC_F10 + BC_F01
	21E	2 1	CL25_300... - CL45_300... + BC_F10 + BC_F01 + BC_F10	CL06_300... - CL10_300... + BC_F10 + BC_F01 + BC_F10
	12E	1 2	CL25_300... - CL45_300... + BC_F10 + BC_F01 + BC_F01	CL06_300... - CL10_300... + BC_F10 + BC_F01 + BC_F01
	31E	3 1	CL25_300... - CL45_300... + BC_F10 + BC_F01 + BC_F10 + BC_F10	CL06_300... - CL10_300... + BC_F10 + BC_F01 + BC_F10 + BC_F10
	41E	4 1		CL06_300... - CL10_300... + BC_F10 + BC_F01 + BC_F10 + BC_F10 + BC_F10
	22E	2 2	CL25_300... - CL45_300... + BC_F10 + BC_F01 + BC_F01 + BC_F10	CL06_300... - CL10_300... + BC_F10 + BC_F01 + BC_F01 + BC_F10
	32E	3 2		CL06_300... - CL10_300... + BC_F10 + BC_F01 + BC_F01 + BC_F10 + BC_F10
	13E	1 3	CL25_300... - CL45_300... + BC_F10 + BC_F01 + BC_F01 + BC_F01	CL06_300... - CL10_300... + BC_F10 + BC_F01 + BC_F01 + BC_F01
	23E	2 3		CL06_300... - CL10_300... + BC_F10 + BC_F01 + BC_F01 + BC_F01 + BC_F10
<b>Lateral mounting auxiliary contact blocks with two contacts each</b>				
	11E	1 1	CL25_300... - CL45_300... + BCLL11	CL06_300... - CL10_300... + BCLL11
	31E	3 1	CL25_300... - CL45_300... + BCLL11 + BCLL20	CL06_300... - CL10_300... + BCLL11 + BCLL20
	22E	2 2	CL25_300... - CL45_300... + BCLL11 + BCLL11	CL06_300... - CL10_300... + BCLL11 + BCLL11

Technical data

Intro

A

B

C

D

E

F

G

H

I

J/X



## Conformity to standards

IEC/EN 60947-1	NF C 63-110	BS 5424 & 775
IEC/EN 60947-4-1	ASE 1025	NEMA ICS 1
CENELEC HD 419	CSA 22.2/14	VDE 0660/102
UL 508	UNE 20109	
EN 50005		

## Approvals

cULus	RINA	CE
NOM	FI	
Lloyd's Register	Bureau Veritas	

## Ambient conditions

Storage temperature	-55°C to +80°C	
Operation temperature	-40°C to +60°C	
Altitude	up to 3000m	Nominal values
	from 3000 up to 4000m	90%Ie 80%Ue
	from 4000 up to 5000m	80%Ie 75%Ue

## Climatic resistance (IEC 68-2)

Continuous tests 40 / 125 / 56		
Cold (72h)		
Temperature	-40°C	
Dry heat (96h)		
Temperature	+125°C	
Relative humidity	< 50%	
Humid heat (56 days)		
Temperature	+40°C	
Relative humidity	95%	
Cyclical test		
First half-cycle (12h)		
Low temperature	+25°C	
Relative humidity	93%	
Second half-cycle (12h)		
Low temperature	+55°C	
Relative humidity	95%	
Number of consecutive cycles	6	

## Terminal capacity and tightening torque

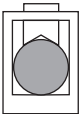
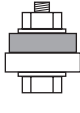
		CK07B	CK75C CK08C	CK08B CK95B	CK10C	CK11C	CK12B	CK13B	
	Solid (mm <sup>2</sup> )	1.5...95							
	Finely stranded w/end sleeve (mm <sup>2</sup> )	2...35							
	Finely stranded w/o end sleeve (mm <sup>2</sup> )	2...50							
	Stranded (mm <sup>2</sup> )	1.5...95							
	AWG wires (mm <sup>2</sup> )	16...00							
Tightening torque	(Nm)	8							
	(Lb x in)	70							
	Finely stranded w/end sleeve (mm <sup>2</sup> )		1 x 120 2 x 95	1 x 240 2 x 150	2 x 185	2 x 240	-	-	
	AWG wires with end sleeve (mm <sup>2</sup> )		1 x 300 2 x 107	1 x 500 2 x 300	2 x 350		2 x 500	-	
	Busbars		2 (25 x 5)	2 (25 x 5)	2 (35 x 10)	2 (35 x 10)	2 (35 x 10)	2 (60 x 10)	
	Tightening torque	(Nm)		8	23	31.5	31.5	31.5	31.5
		(Lb x in)		70	200	275	275	275	275

## Mounting positions

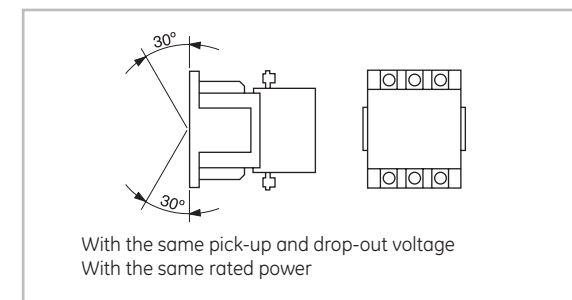



**Electrical endurance**

*Mixed category AC4 / AC3*

Electrical endurance for mixed category (AC-3/AC-4) is calculated with the following formula:

$$\text{Electrical endurance (AC-3/AC-4)} = \frac{\text{Electrical endurance (AC-3)}}{1 + \frac{\% \text{ oper AC-4}}{100} \times \left( \frac{\text{Elec.endur. (AC-3)}}{\text{Elec.endur. (AC-4)}} - 1 \right)}$$

*Category AC1*

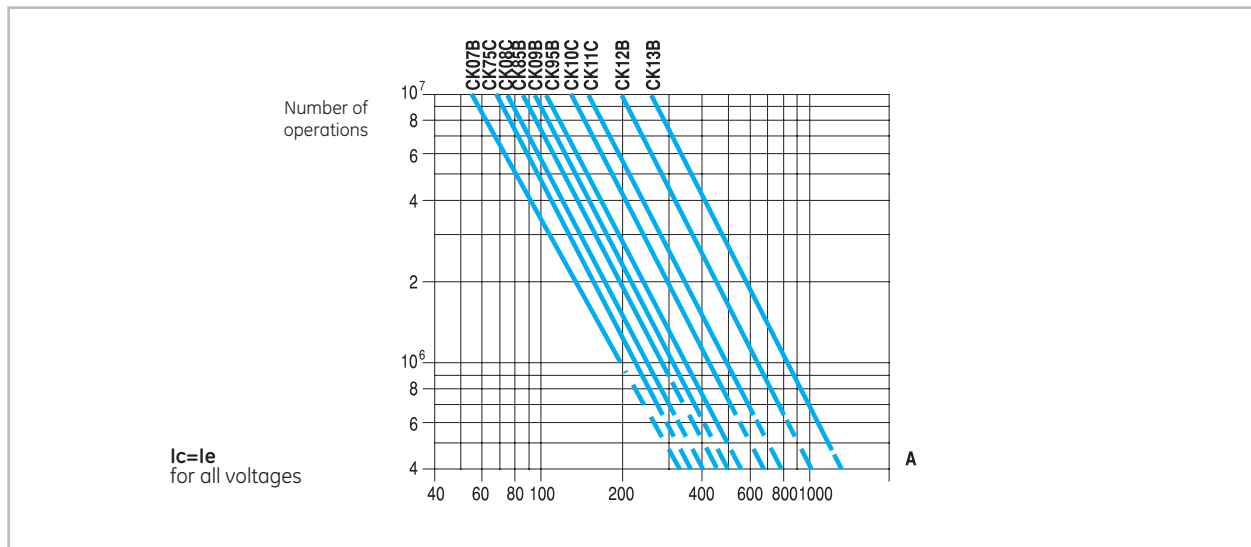

*Category AC2*

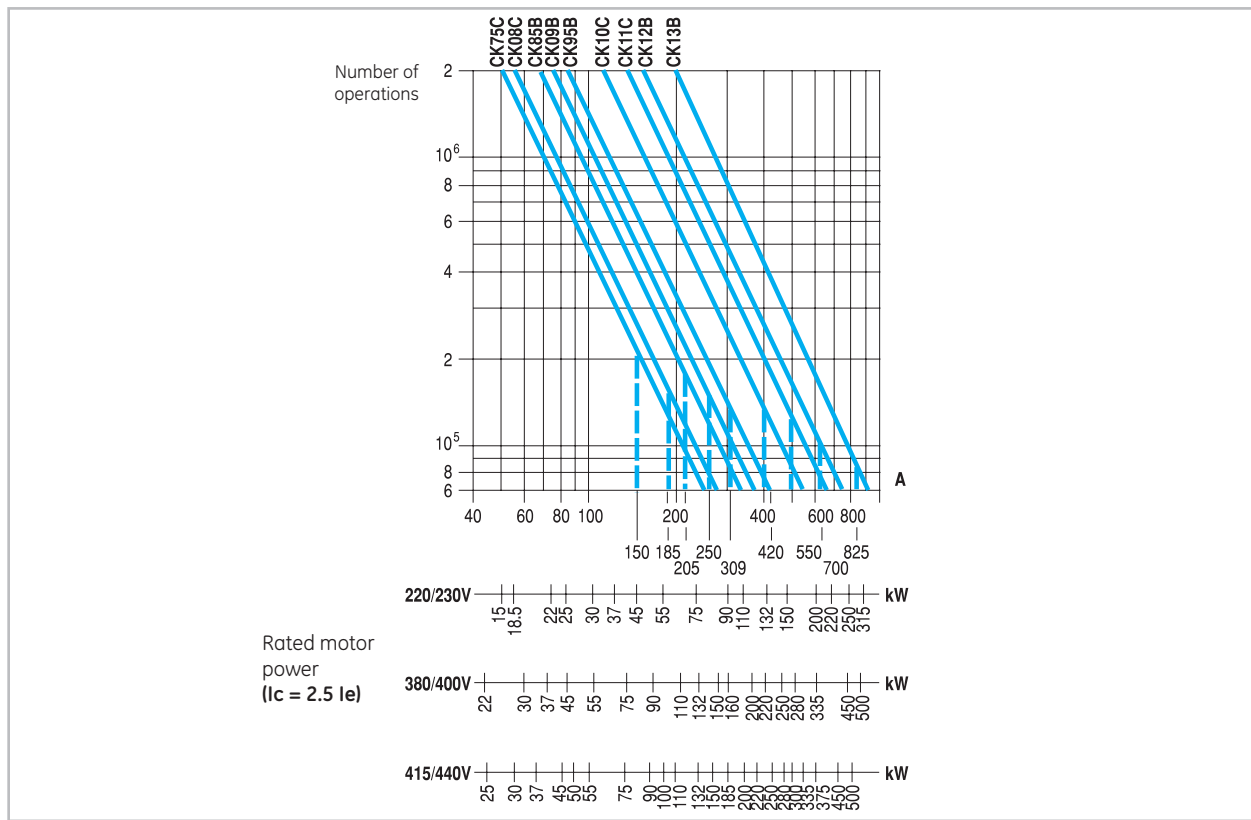

Contactors

Intro

A

B

C

D

E

F

G

H

I

J/X



Electrical endurance (continued)

Category AC3

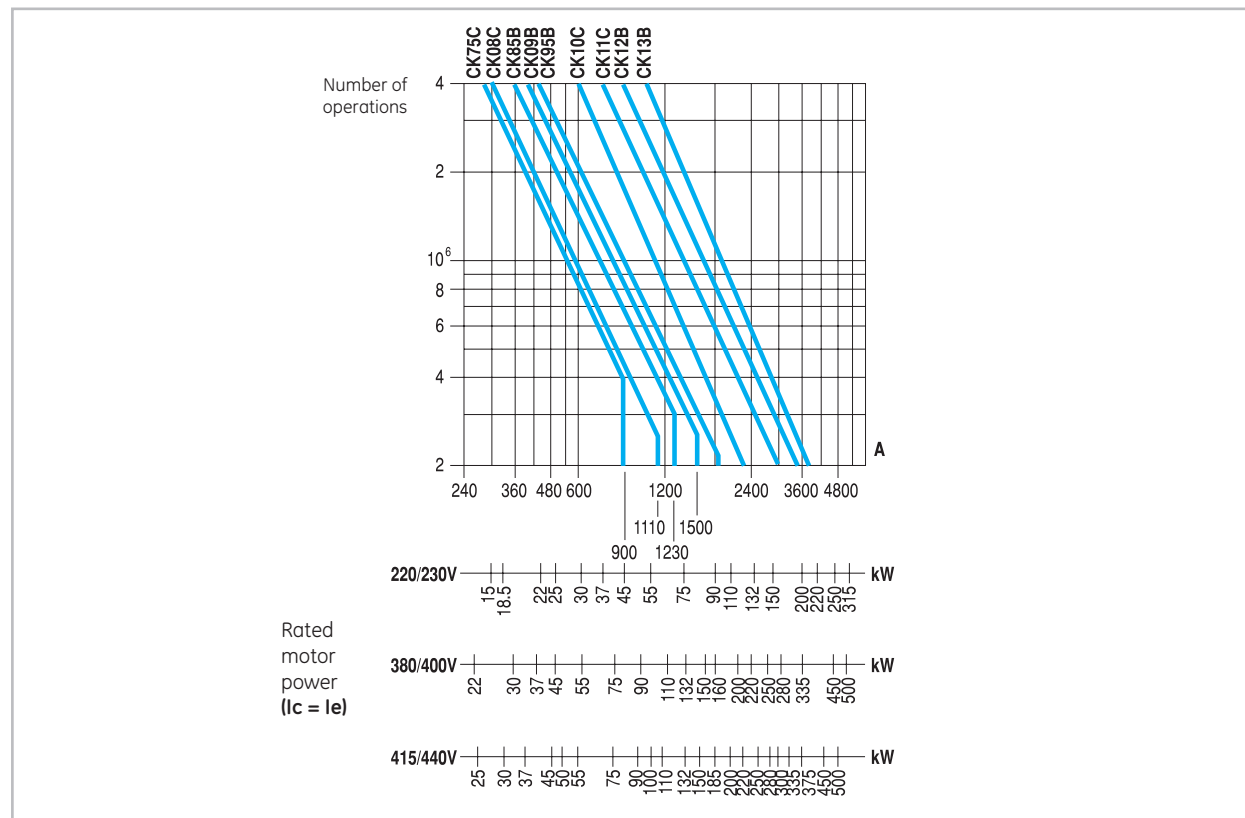

Category AC4

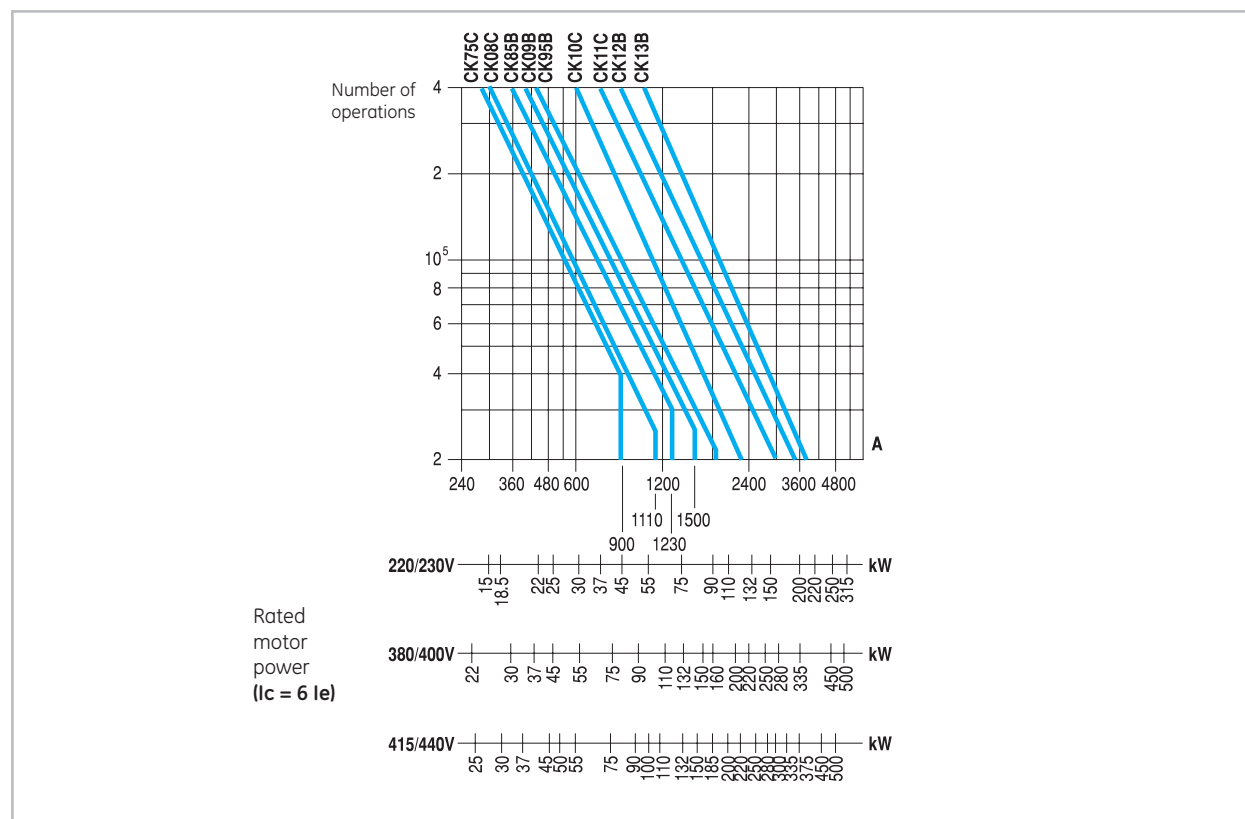

Technical data

Intro

A

B

C

D

E

F

G

H

I

J/X







Four pole contactors. Control circuit

Alternating current

		CK07BA CK07BE	CK08BA CK08BE	CK09BE	CK95BE	CK10CE	CK11CE	CK12BE	CK12BE	CK13BA
Rated insulation voltage U <sub>i</sub>	(V)	1000	1000	1000	1000	1000	1000	1000	1000	1000
Standard voltages U <sub>s</sub> (50/60 Hz)	(V)	24...690	24...690	24...690	24...690	24...690	24...690	24...72	100...690	110...440
Operating limits										
Switch-on	xU <sub>s</sub>	0.85...1.1	0.85...1.1	0.85...1.1	0.85...1.1	0.85...1.1	0.85...1.1	0.85...1.1	0.85...1.1	0.85...1.1
Switch-off	xU <sub>s</sub>	0.2...0.75	0.2...0.75	0.2...0.75	0.2...0.75	0.2...0.75	0.2...0.6	0.2...0.75	0.2...0.75	0.2...0.75
Consumption. Monofrequency coils										
Magnetic circuit	CK...A (VA)	46	130	-	-	-	-	-	-	6
closed	CK...E (VA)	20	25	25	25	23	23	25	25	-
Magnetic circuit	CK...A (VA)	830	2860	-	-	-	-	-	-	2760
open	CK...E (VA)	425	750	750	750	680	680	750	750	-
Power	CK...A (W)	17	53	-	-	-	-	-	-	5
dissipation	CK...E (W)	3.5	4.5	4.5	4.5	4	4	4.5	4.5	-
Consumption. Bifrequency coils										
Magnetic circuit	50Hz (VA)	60	159.3	-	-	-	-	-	-	-
closed (CK...A)	60Hz (VA)	50	132.7	-	-	-	-	-	-	-
Magnetic circuit	50Hz (VA)	1082	3509	-	-	-	-	-	-	-
open (CK...A)	60Hz (VA)	901	2924	-	-	-	-	-	-	-
Power	50Hz (W)	22.2	65.3	-	-	-	-	-	-	-
dissipation (CK...A)	60Hz (W)	18.5	54.4	-	-	-	-	-	-	-
Power factor										
Magnetic circuit	CK...A (cos φ)	0.37	0.37	-	-	-	-	-	-	approx. 1
closed	CK...E (cos φ)	-	-	-	-	-	-	-	-	-
Magnetic circuit	CK...A (cos φ)	0.6	0.6	-	-	-	-	-	-	approx. 1
open	CK...E (cos φ)	-	-	-	-	-	-	-	-	-
Opening and closing times at U <sub>s</sub>										
Making time	(ms)	36...40	60...70	70...80	70...80	110...115	80...90	150...170	110...115	50...55
at excitation (NO)										
Breaking time	(ms)	10...15	13...17	70...80	70...80	70...80	70...80	70...80	70...80	70...80
at de-energisation (NO)										
Mechanical endurance	10 <sup>6</sup> ops.	10	6.5	6.5	6.5	6.5	6.5	3.5	3.5	3
Maximum rate										
No load	ops./h	2400	900	900	900	900	900	900	900	600
AC-1/AC-3 at rated power	ops./h	600	600	600	600	300	300	300	300	120

(1) Mechanical endurance for e-module is 1 Million operations

Direct current - Electronic module

		CK07BE	CK08BE	CK08BE	CK95BE	CK10CE	CK11CE	CK12BE	CK12BE
Rated insulation voltage U <sub>i</sub>	(V)	1000	1000	1000	1000	1000	1000	1000	1000
Standard voltages U <sub>s</sub>	(V)	24...500	24...500	24...500	24...500	24...500	24...500	24...72	110...500
Operating limits									
Switch-on	xU <sub>s</sub>	0.75...1.1	0.8...1.1	0.8...1.1	0.8...1.1	0.8...1.1	0.8...1.1	0.8...1.1	0.8...1.1
Switch-off	xU <sub>s</sub>	0.2...0.75	0.2...0.75	0.2...0.75	0.2...0.75	0.2...0.75	0.2...0.75	0.2...0.75	0.2...0.75
Consumption									
Magnetic circuit closed	(W)	10	10	10	10	10	10	10	10
Magnetic circuit open	(W)	350	650	650	650	650	650	650	650
Opening and closing times at U <sub>s</sub>									
Making time	(ms)	60...70	70...80	70...80	70...80	80...90	80...90	150...170	110...115
at excitation (NO contacts)									
Breaking time	(ms)	40...50	70...80	70...80	70...80	60...80	60...80	60...90	60...90
at de-energisation (NO contacts)									
Mechanical endurance	10 <sup>6</sup> ops.	10	6.5	6.5	6.5	6.5	6.5	3.5	3.5
Maximum rate									
No load	ops./h	1200	900	900	900	900	900	900	900
AC-3 at rated power	ops./h	600	600	600	600	600	300	300	300

(1) Mechanical endurance for e-module is 1 Million operations

Technical data

Intro

A

B

C

D

E

F

G

H

I

J/X



Contact sequence

		Basic contactor	Auxiliary contact blocks Lateral mounted	
			BCLL 20 BRLL 20	BCLL 11 BRLL 11
Three-pole contactors 3 NO	CK75C... CK08C...			
	CK85B... CK09B... CK95B...			
	CK10C... CK11C...			
	CK12B... CK13B...			
	CK07B...			
	CK08B... CK09B... CK95B...			
	CK10C... CK11C...			
	CK12B... CK13B...			

Numbering of the terminals

Three pole contactors

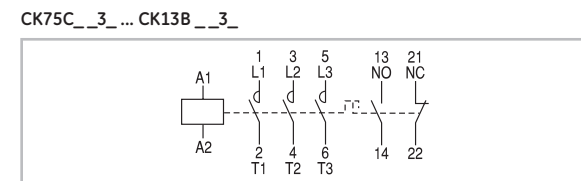

Four pole contactors

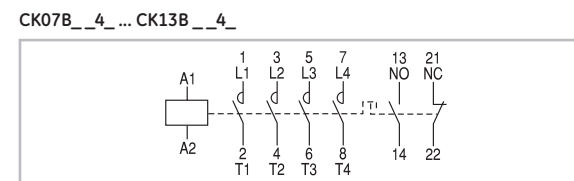

Auxiliary contact blocks. Lateral mounting

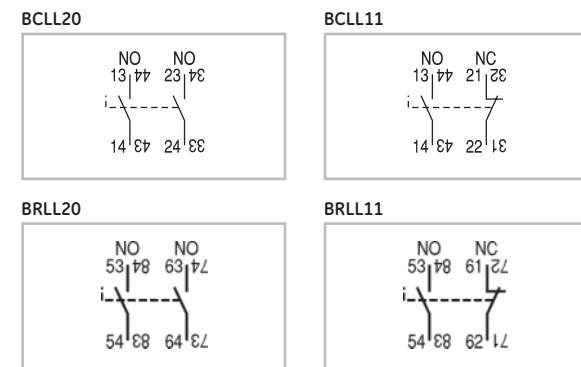

Voltage suppressor block

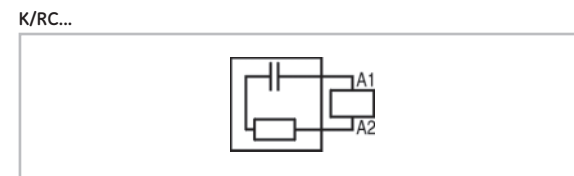

Mechanical interlock



A  
 B  
 C  
 D  
 E  
 F  
 G  
 H  
 I  
 J/X





Notes

Grid area for notes

Technical data

Intro

A

B

C

D

E

F

G

H

I

J/X



Dimensional drawings

Three and four pole contactors

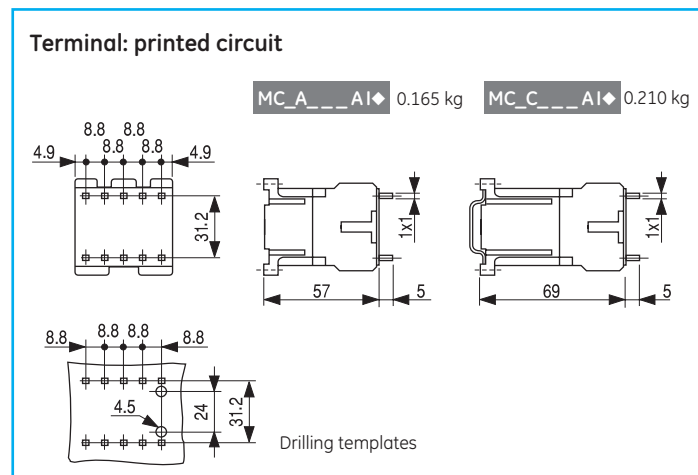
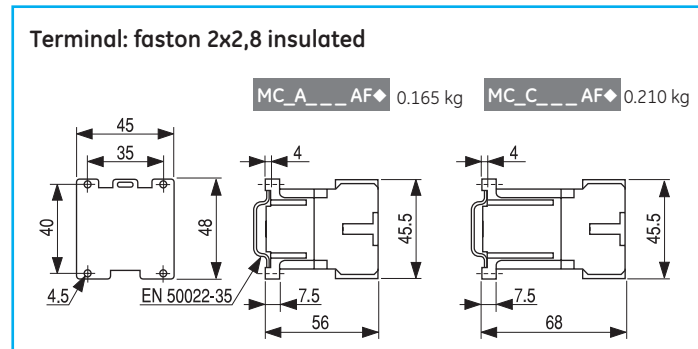
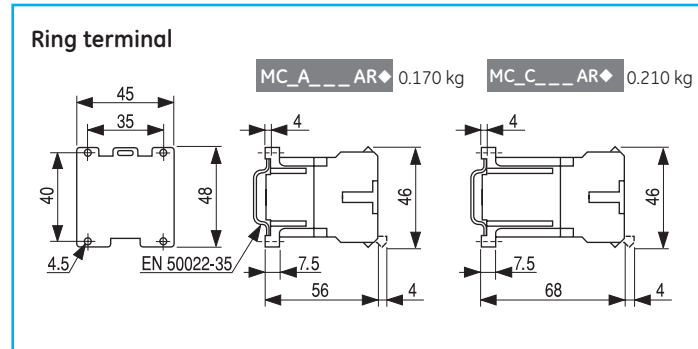
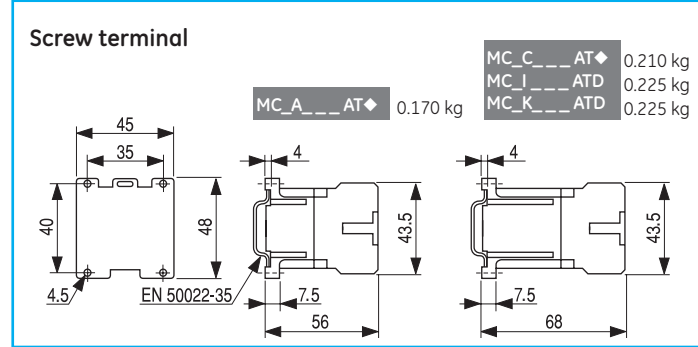

Auxiliary contact block. Lateral mounting

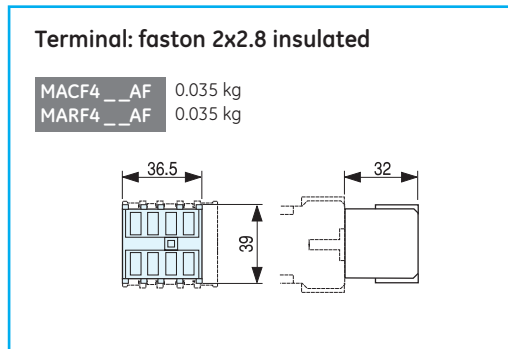
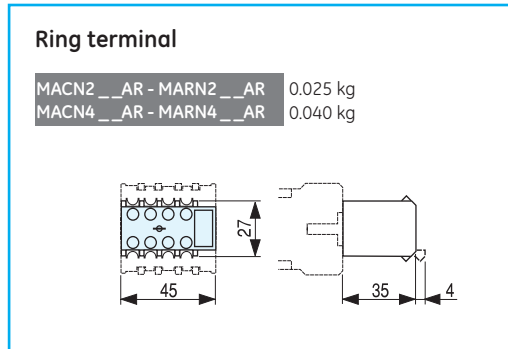
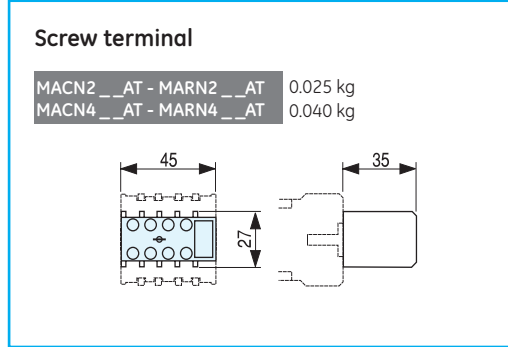

Auxiliary contact blocks. Lateral mounting

**Screw terminal**

MACL\_\_AT 0.013 kg  
MARL\_\_ATS 0.013 kg

(1) AC-control.  
(2) DC-control.

**Ring terminal**

MACL\_\_AR 0.013 kg  
MARL\_\_ARS 0.013 kg

(1) AC-control.  
(2) DC-control.

**Terminal: faston 2x2.8 insulated**

MACL\_\_AF 0.009 kg  
MARL\_\_AFS 0.009 kg

(1) AC-control.  
(2) DC-control.

**Terminal: printed circuit**

MACL\_\_AI 0.009 kg  
MARL\_\_AIS 0.009 kg

(1) AC-control.  
(2) DC-control.

Electronic timer block

MREBC\_0AC2 0.040 kg

(1) Frontal mounting  
(2) Lateral mounting

Voltage suppressor block

MPOA\_AE\_ 0.010 kg  
MPOC\_AE3 0.010 kg

Dimensions

Intro

A

B

C

D

E

F

G

H

I

J/X



Dimensional drawings. Three pole contactors

Alternating current

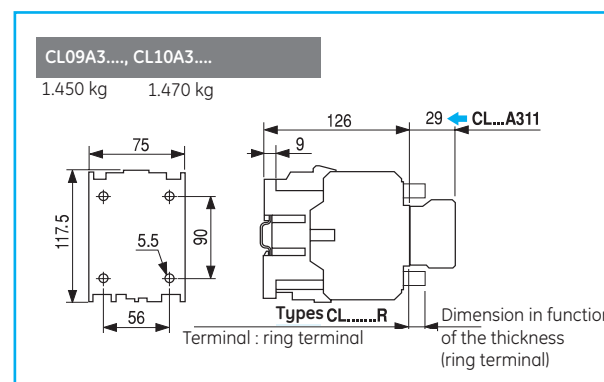
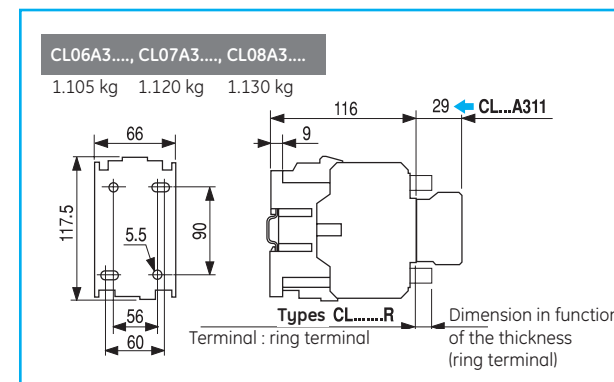
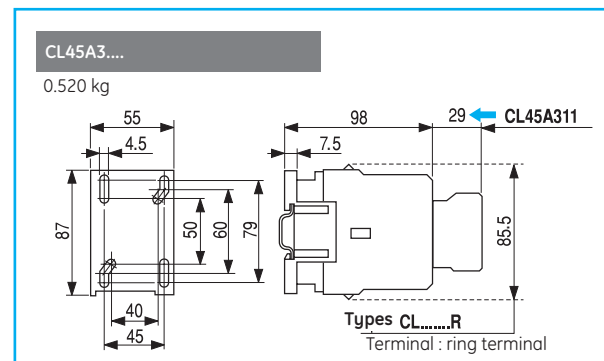
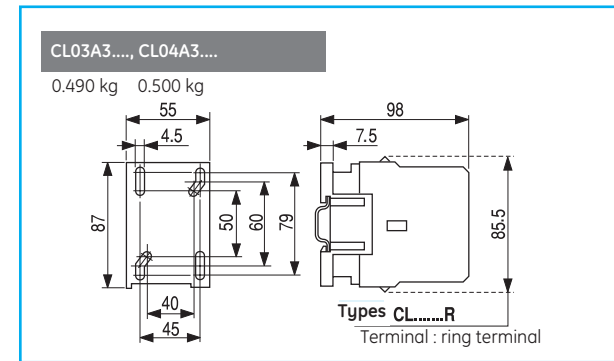
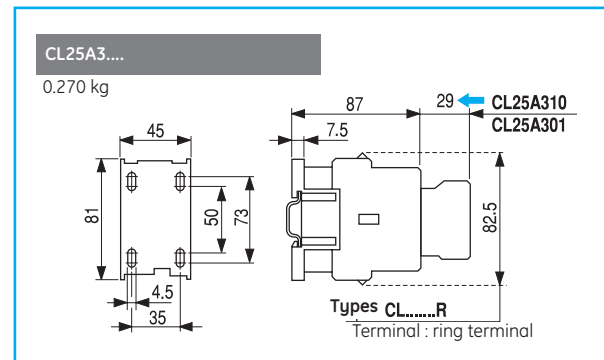
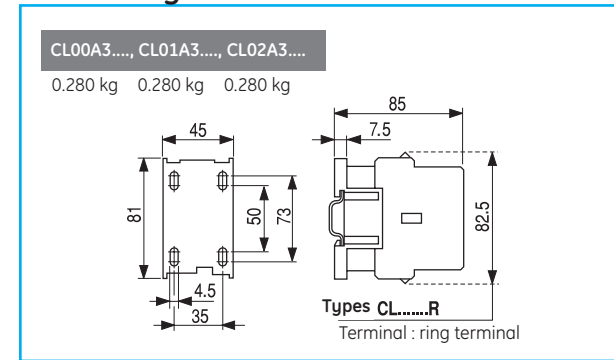

Three pole contactors

Direct current

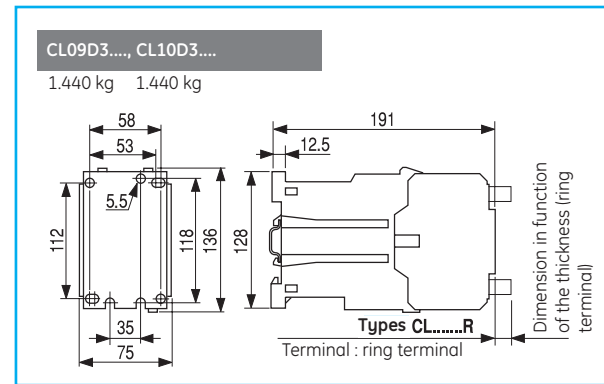
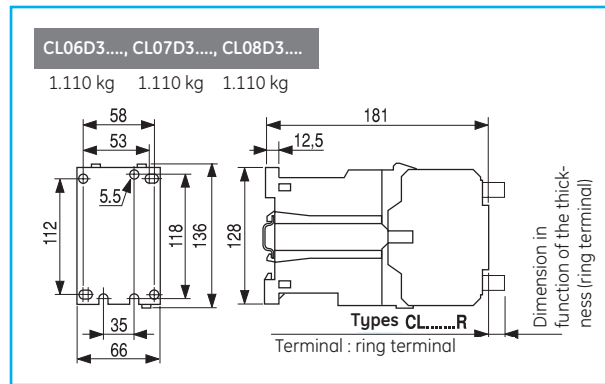
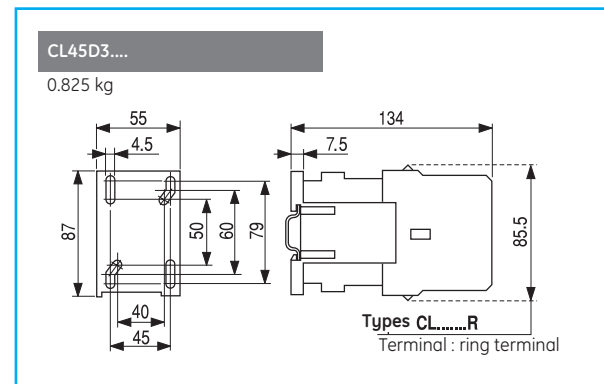
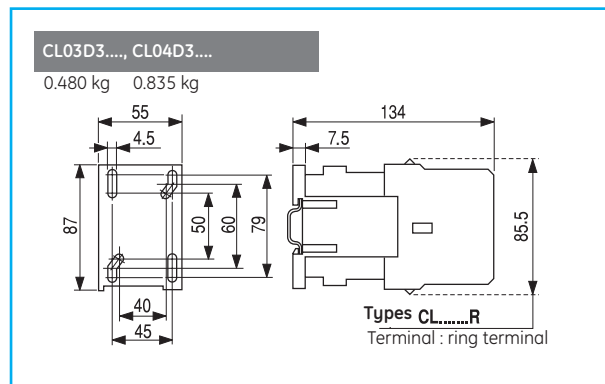
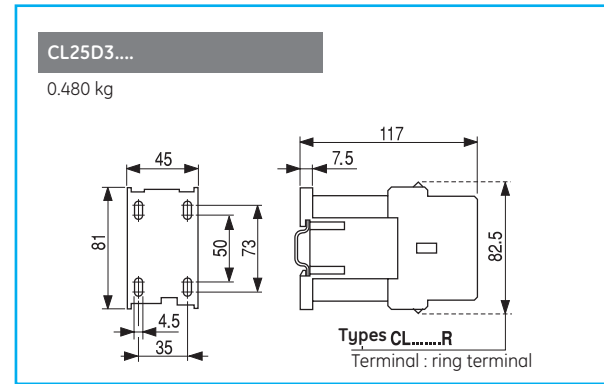
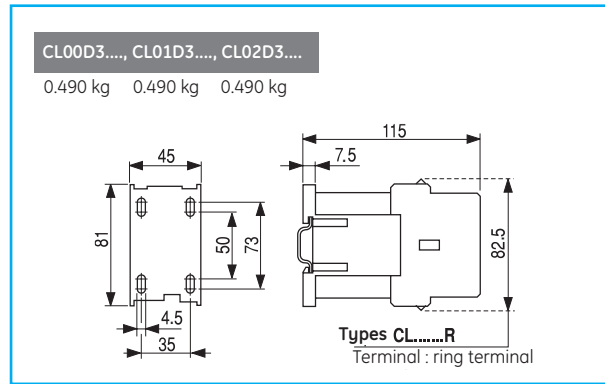

Coil with electronic module

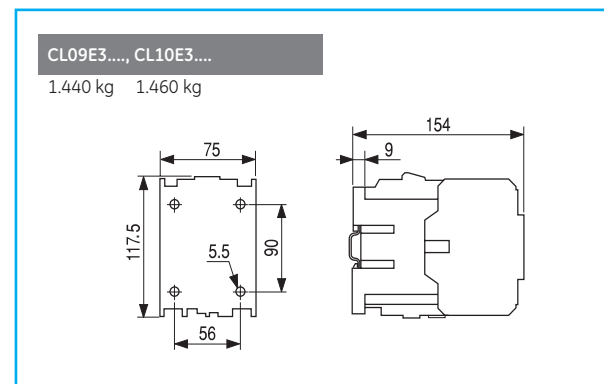
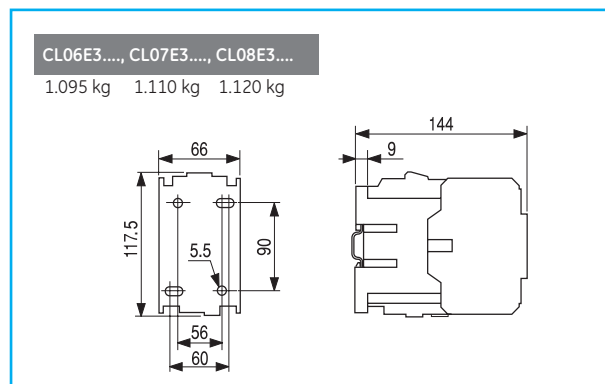

Dimensions

Intro

A

B

C

D

E

F

G

H

I

J/X



Dimensional drawings. Four pole contactors

Alternating current

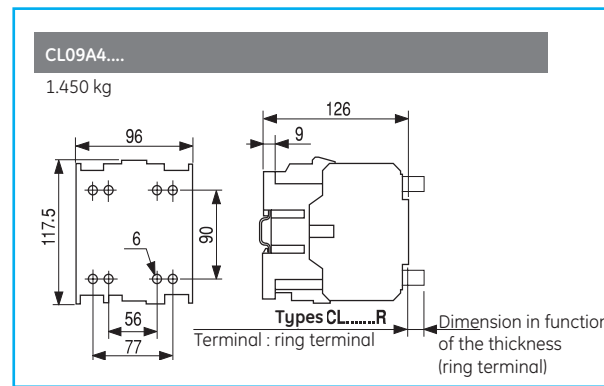
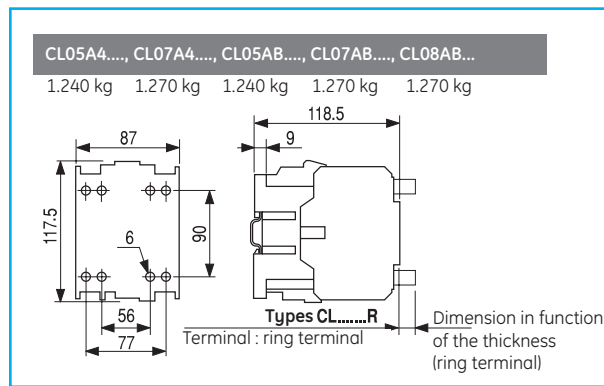
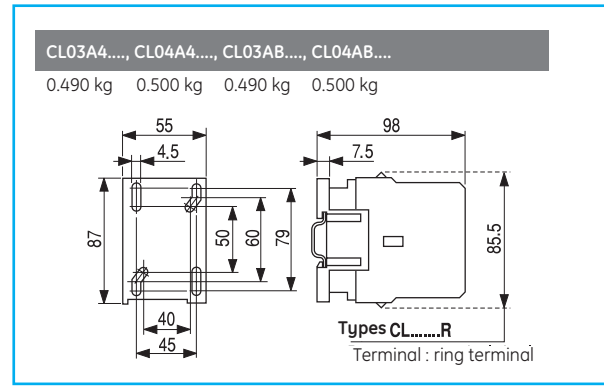
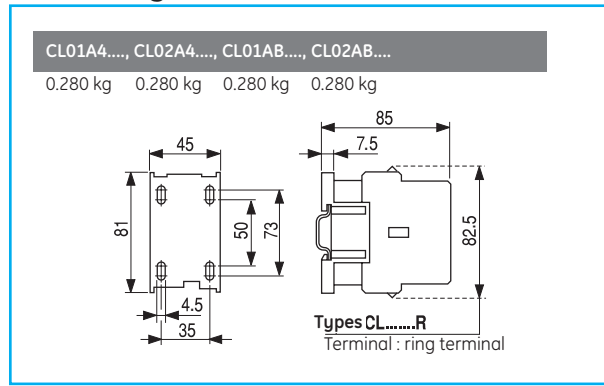

Direct current

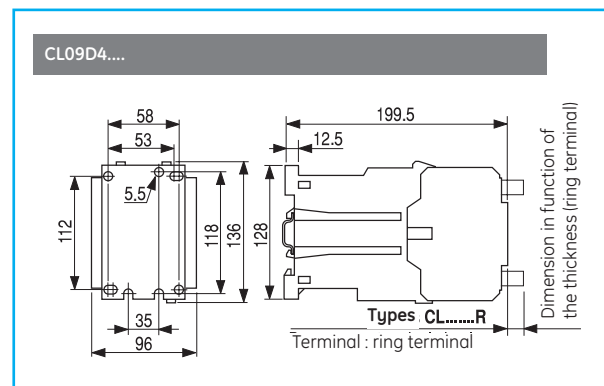
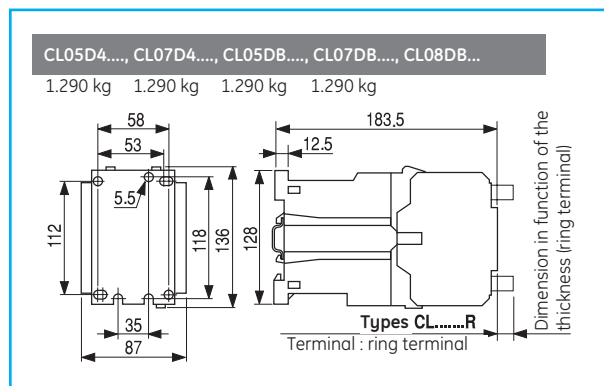
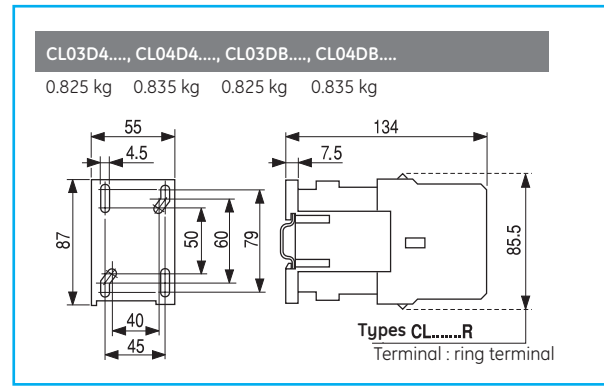
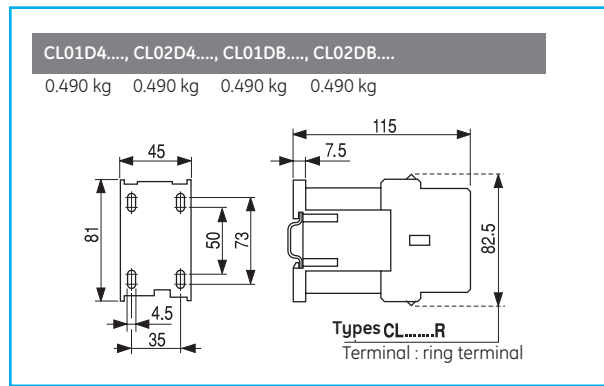



Four pole contactors

Coil with electronic module

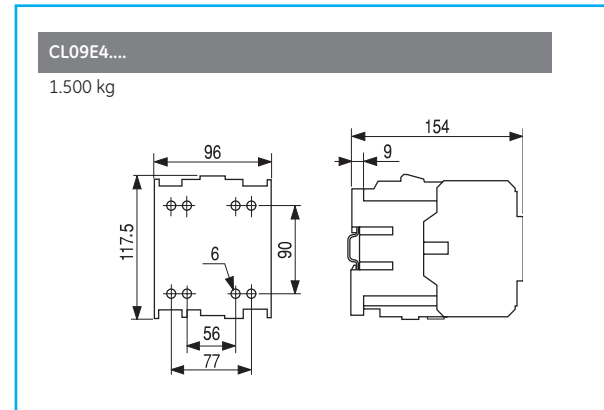
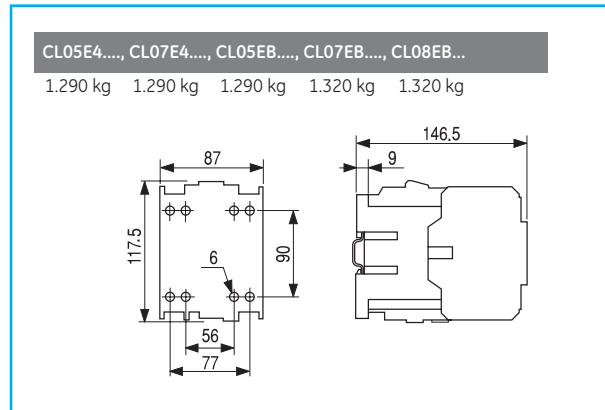

Dimensions

Intro

A

B

C

D

E

F

G

H

I

J/X



**Dimensional drawings**

**Auxiliary contact blocks**

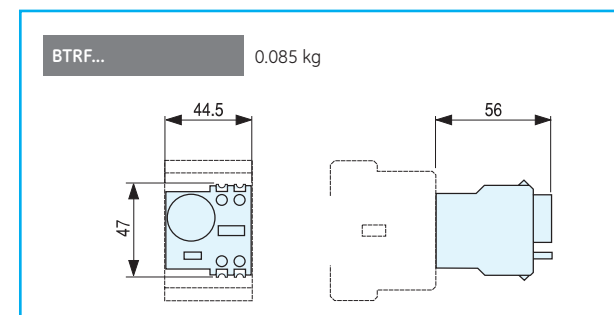
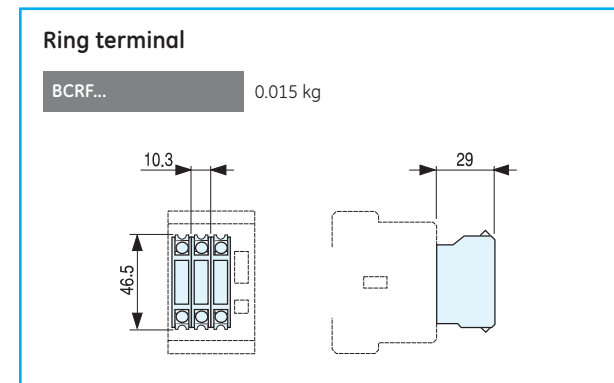
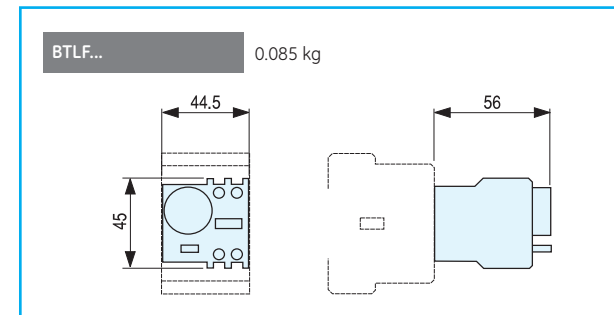
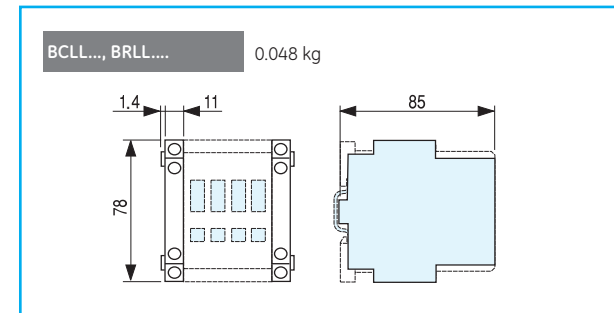
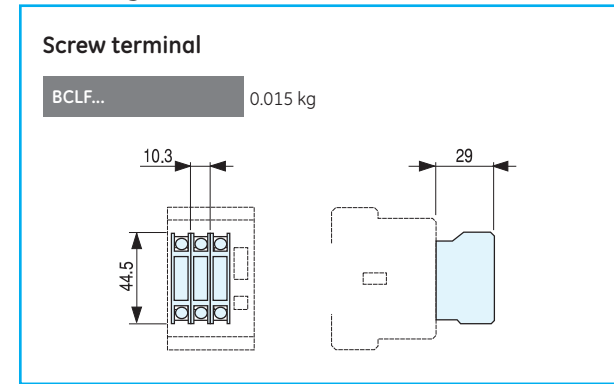

**Accessories**

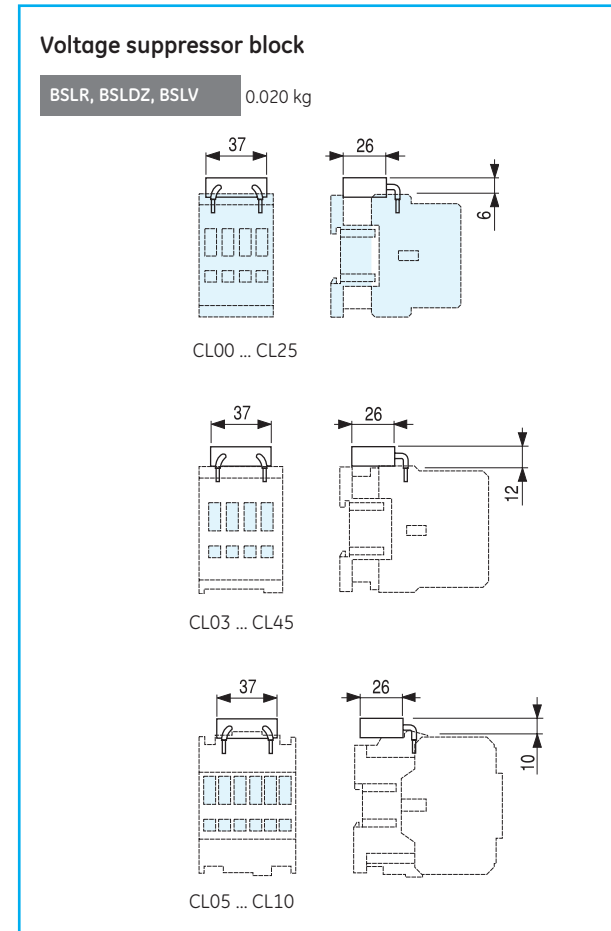

**Mechanical latch block**

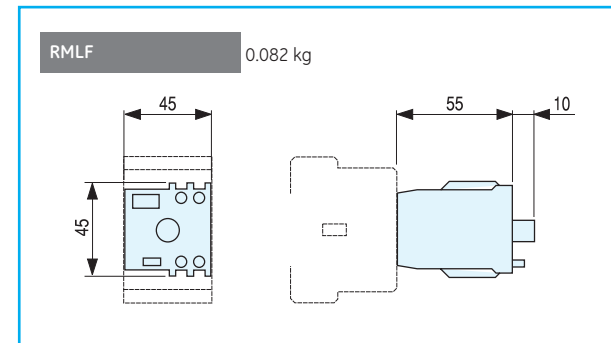

**Mechanical / mechanical-electrical interlock**

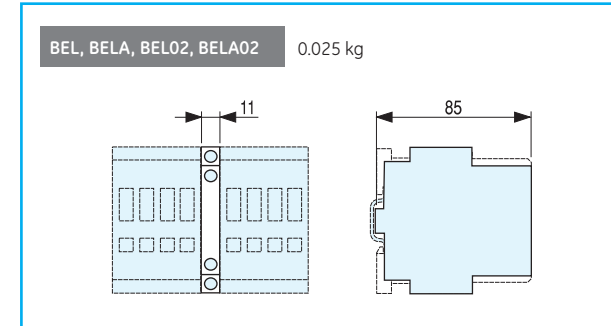

Contactors  
Intro  
A  
B  
C  
D  
E  
F  
G  
H  
I  
J/X



Electronic timer block

BETL02, BETL45 0,040 kg

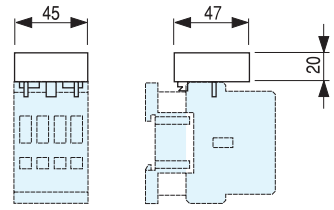

CL00 ... CL25

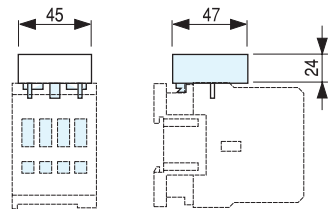

CL03 ... CL45

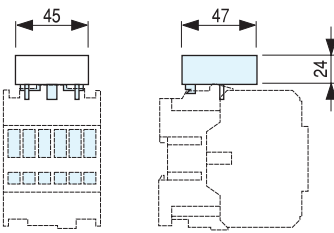

CL05 ... CL10

Interface modules

IMR..., IMRF..., IMSSD, IMAMS 0,020 kg

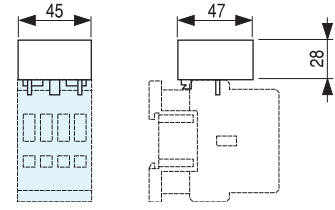

CL00 ... CL25

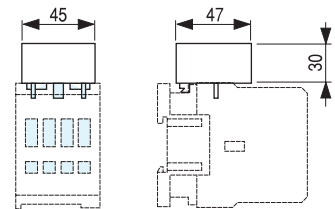

CL03 ... CL45

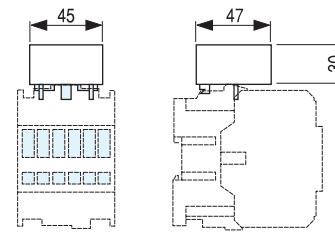

CL05 ... CL10

Dimensions

Intro

A

B

C

D

E

F

G

H

I

J/X



Dimensional drawings

Three pole contactors

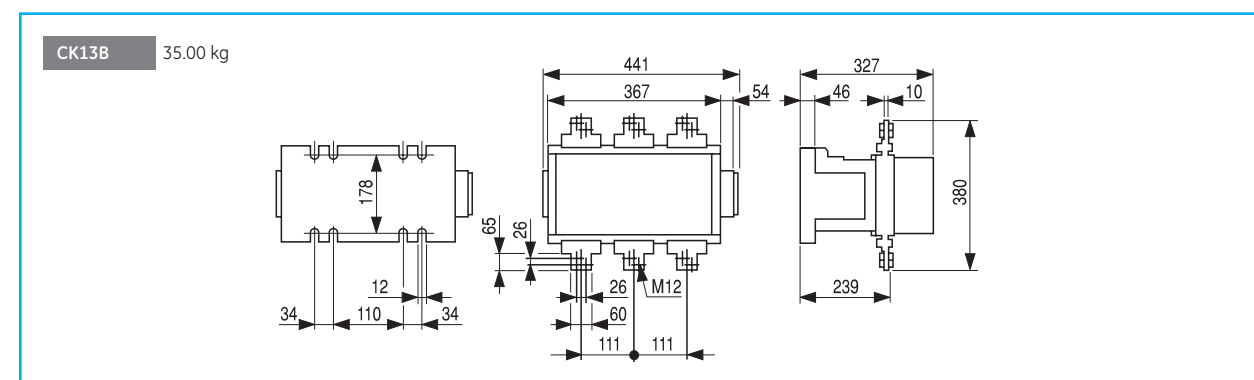
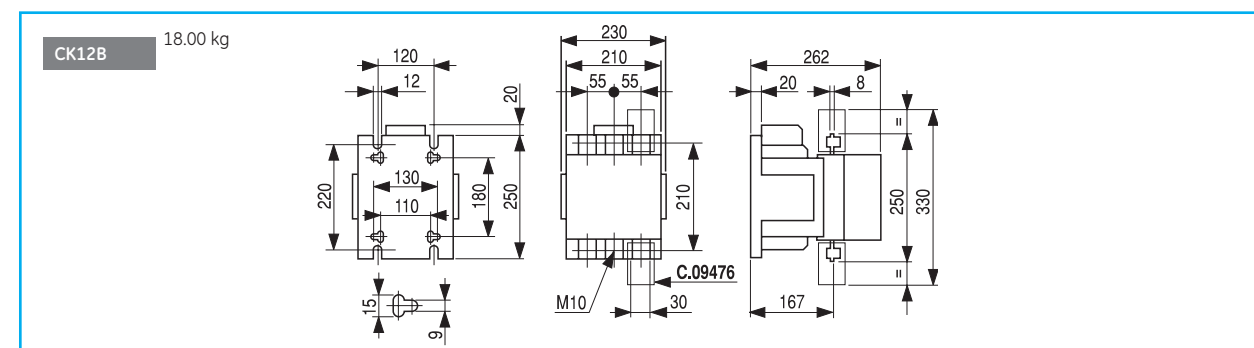
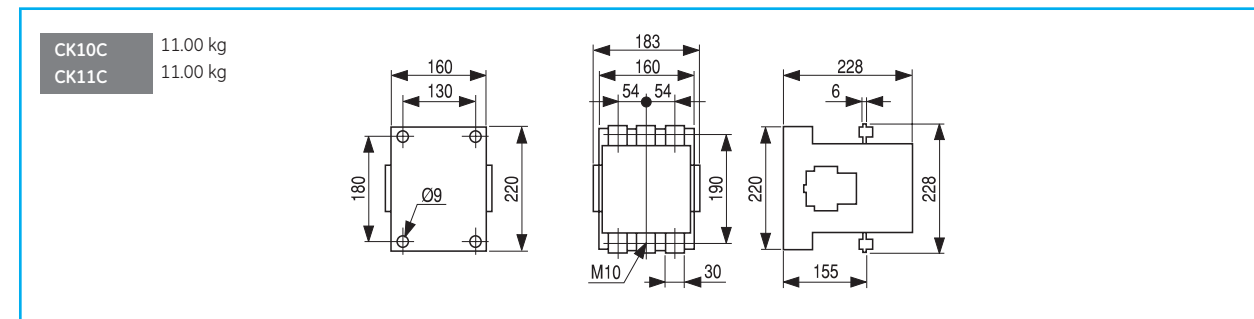
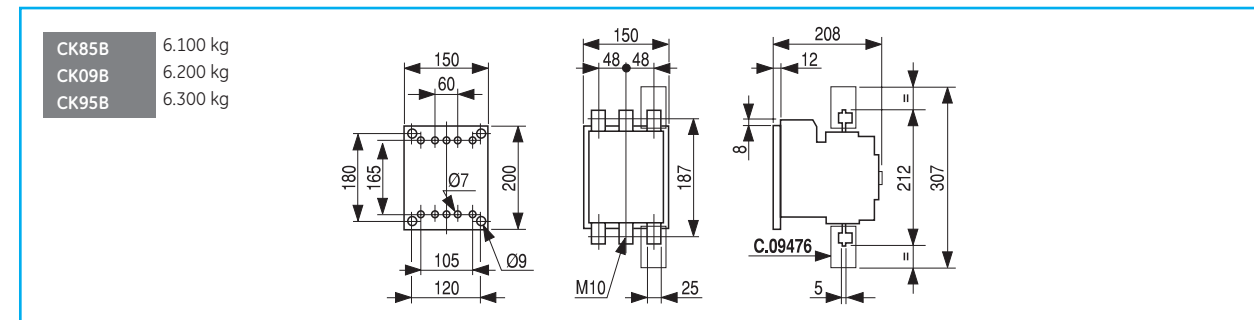
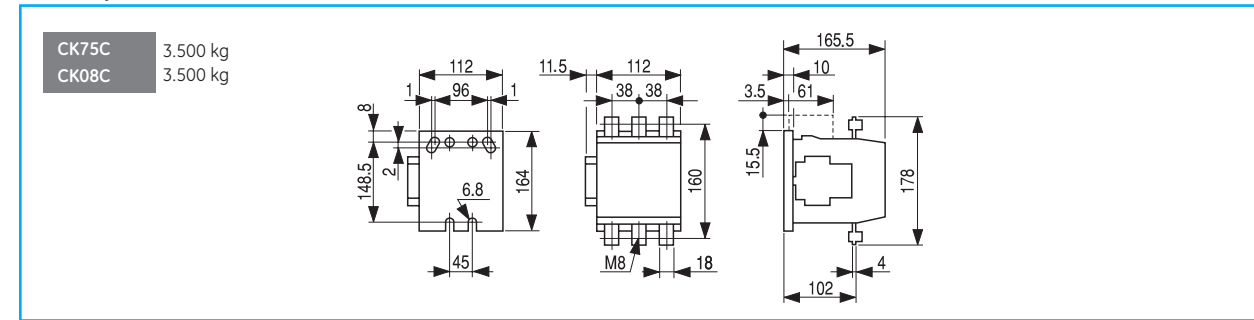

A  
 B  
 C  
 D  
 E  
 F  
 G  
 H  
 I  
 J/X



Four pole contactors

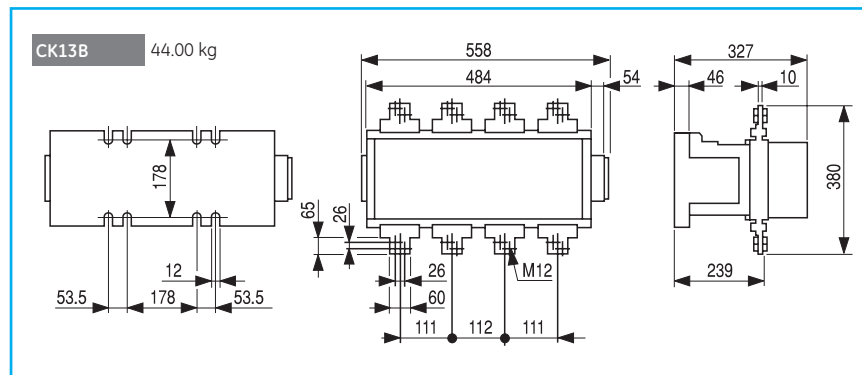
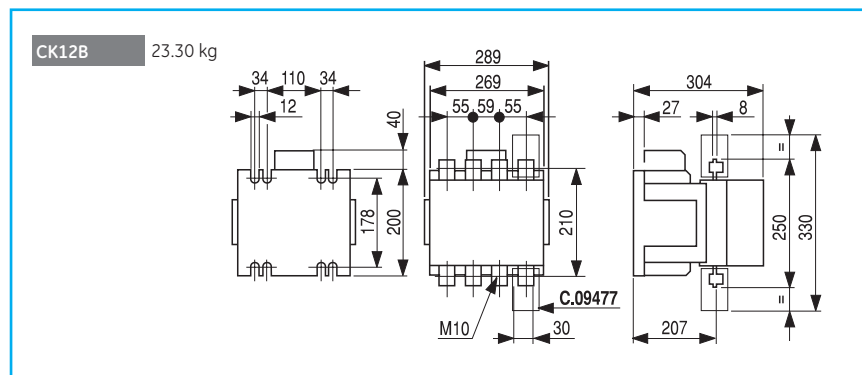
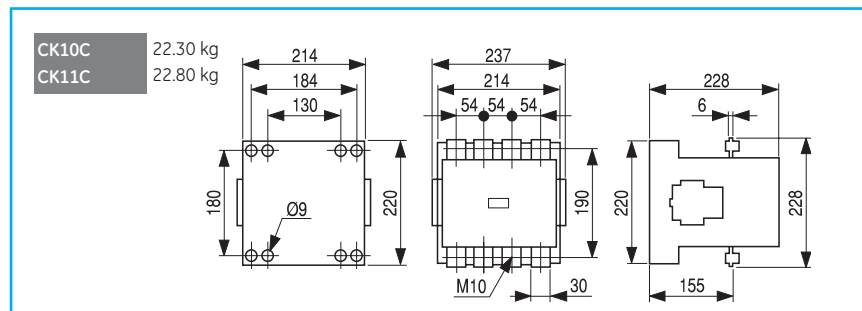
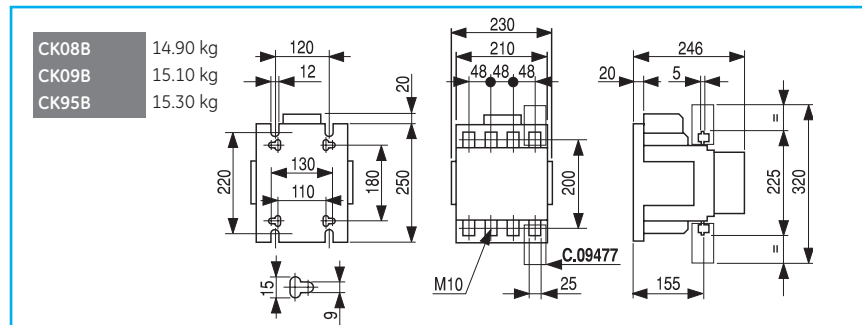
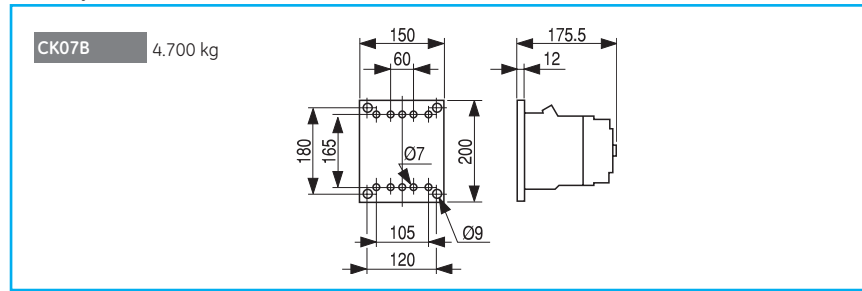

Mechanical interlock

**BEKH** 0.350 kg

	A
CK75C3... - CK08C3...	55
CK85B3... - CK95B3...	55
CK10C3... - CK11C3...	33
CK12B3...	75

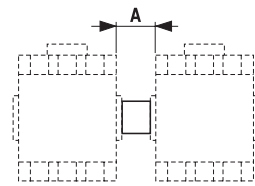

	A	
BEKVA1	550	0.900 kg
BEKVS1	350	0.800 kg

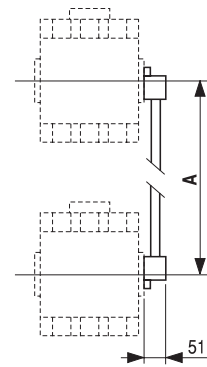

**BEKV** 1.200 kg

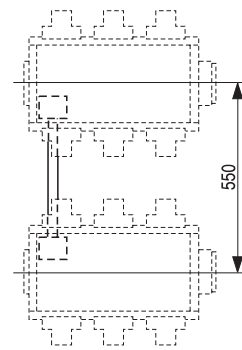

Dimensions

Intro

A

B

C

D

E

F

G

H

I

J/X



Technical data

General

- Thermal protection against balanced overload.
- Three-pole differential ( phase unbalance protection).
- Automatic ambient temperature compensation.
- Front mounted selector for choosing utilisation current.
- Reset button, 2 positions :  
Manual(H) and Automatic(A) by turning the blue selector.
- Stop push button, independent of reset (red).
- Manual trip lever (tripping test).
- Tripping indicator (0-1).
- To facilitate wiring arrangements terminal 96 fits directly onto coil terminal (A2) and terminal 14/22 fits directly onto the feedback auxiliary contact.

Conformity to standards

IEC 60947-4	CEI 17-50	VDE660
UNE 115	NI C63-650	UL508
NFC63-650		

Approvals

UL	CSA	SEMKO
SETI	NEMKO	CE

Ambient conditions

Storage temperature	-55°C to +80°C	
Operation temperature	-25°C to +60°C	
Altitude	up to 3000m	Nominal values
	from 3000 to 4000m	90%Ie 80%Ue
	from 4000 to 5000m	80%Ie 75%Ue
Degree of protection	IP20	
Protection treatment	Tropical finish	

Climatic resistance

Continuous tests 40 / 125 / 56		
Cold (72h)	Temperature	-40°C
	Relative humidity	< 50%
Dry heat (96h)	Temperature	+125°C
	Relative humidity	< 50%
Humid heat (56 days)	Temperature	+40°C
	Relative humidity	95%
Cyclical tests		
First half-cycle (12h)	Low temperature	+25°C
	Relative humidity	93%
Second half-cycle (12h)	Low temperature	+55°C
	Relative humidity	95%
Number of consecutive cycles	6	

Mounting positions

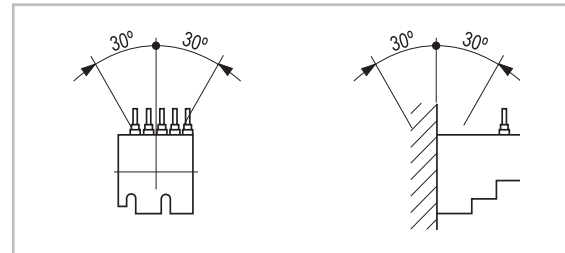

Main circuit (poles)

		MT0...
Rated insulation voltage (Ui) according to IEC 947	(V)	750
Frequency	(Hz)	0...400
Power dissipation per pole	(W)	min. 1 / max. 2.5
Terminal capacity		
Screw M 3.5 (pozidrive head) safety flange		
Maximum capacity :		
Solid	(Ø mm)	2 x 2 wires
Stranded without end sleeve	(mm²)	2 wires Ø 2.5
Stranded with end sleeve		
pen (2 end sleeves)	(mm²)	2 wires Ø 0.75
pen (1 end sleeve)	(mm²)	2 wires Ø 1
		1 wires Ø 2.5
Tightening torque	(Nm)	0.8

Control circuit (incorporated auxiliary contact)

		MT0...
Rated insulation voltage (Ui) according to IEC 947	(V)	750
Rated thermal current (Ith) $\theta \leq 60^\circ\text{C}$	(A)	10
Tripping currents		
AC-15	Ue-Ie (V-A)	223-3, 380-2, 500-1
DC-13	Ue-Ie (V-A)	60-0.5, 110-0.2, 220-0.1
Short-circuit protection (max.glass gL fuse - w/h welding)	(A)	6
Number and type of contacts		

Control circuit (auxiliary contact block)

		MATV10AT
Rated insulation voltage (Ui) according to IEC 947	(V)	750
Rated thermal current (Ith) $\theta \leq 60^\circ\text{C}$	(A)	10
Tripping currents		
AC-15	Ue-Ie (V-A)	223-1, 380-0.5
DC-13	Ue-Ie (V-A)	60-0.1, 110-0.5
Short-circuit protection (max.glass gL fuse - w/h welding)	(A)	6
Number and type of contacts		



Numbering of the terminals

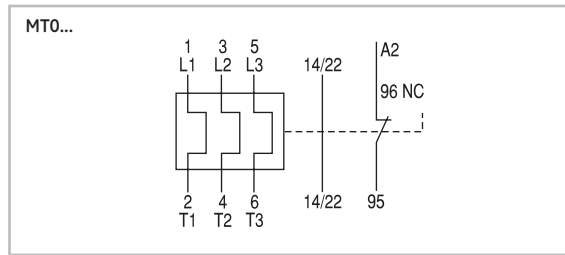

Tripping curves

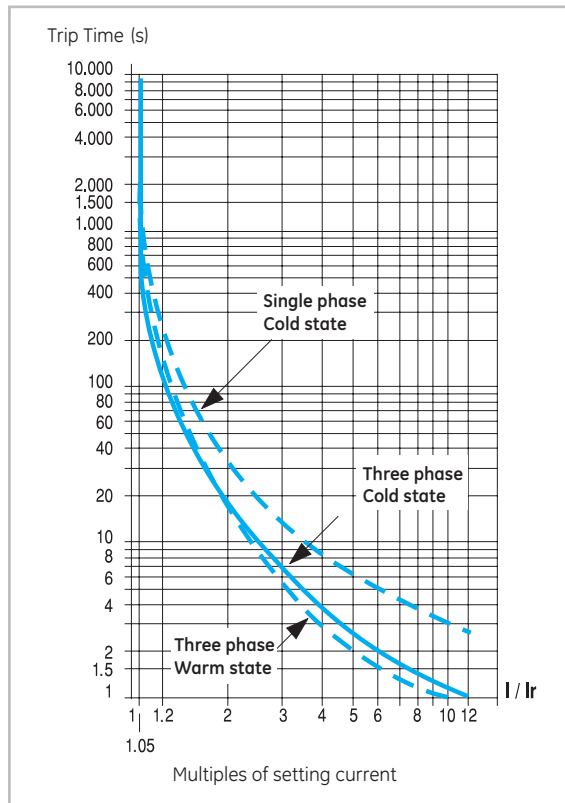

Dimensional drawings

Thermal overload relay

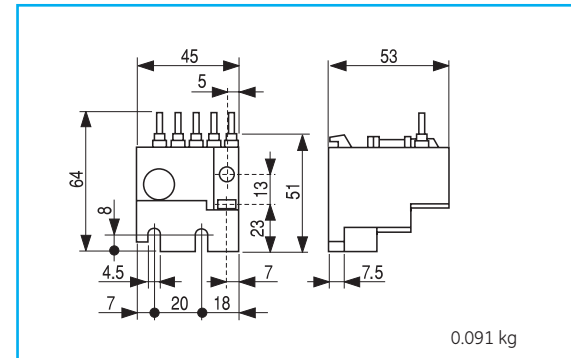

Thermal overload relay + aux. contact block (front mounting)

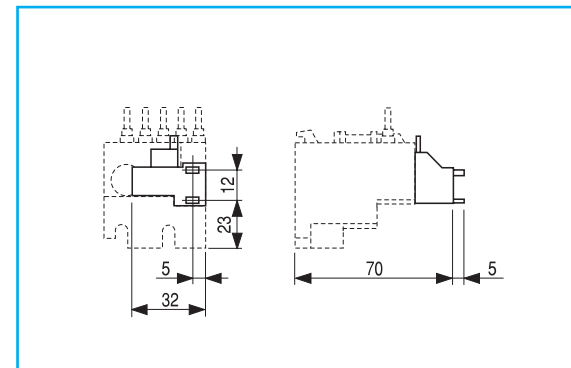

Independent mounting of the thermal overload relay

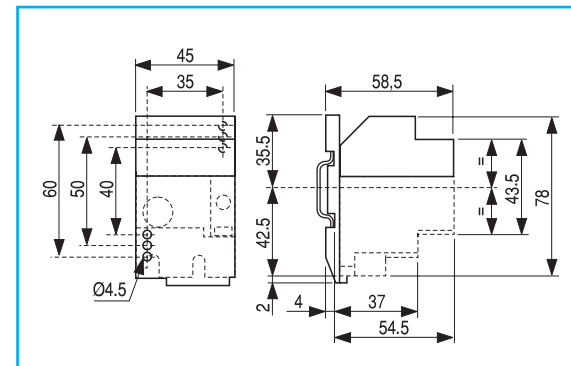

Technical data

Intro

A

B

C

D

E

F

G

H

I

J/X



Technical data

	RT1...	RT2...	RT3...	RT4.../ 4L...	RT5.../ 5L...	RT6.../ 6L...
<b>General</b>						
Class	10A / 20	10 / 20	10 / 20	10 / 30	10 / 30	10 / 30
Setting range	(A) 0.16 ... 40	11.5 ... 110	55 ... 190	2.5 ... 310	120 ... 700	500 ... 850
Suitable for	CL00...CL45	CL05...CL10	CK75...CK08	CL,CK	CK10...CK12	CK13
<b>Main circuit</b>						
Rated insulation voltage (IEC947-4) Ui	(V) 690	1000	1000	1000	1000	1000
Frequency limits	(Hz) 0..400	0..400	0..400	50..60	50..60	50..60
Terminal capacity						
Clamp terminal - solid	(mm <sup>2</sup> ) 16	50	120	-	-	-
Clamp terminal - flexible	(mm <sup>2</sup> ) 10	50	120	-	-	-
Flat terminal	(mm) -	-	25 x 5	-	-	80 x 10
Passing by hole (wire) through C.T. core	(mm <sup>2</sup> ) -	-	-	-	400	-
Passing by hole (bar) through C.T. core	(mm) -	-	-	30 x 10	30 x 10	-
Tightening torque	(Nm) 2.5	4.5	6.5	23	31.5	-
<b>Control circuit</b>						
Rated insulation voltage (IEC60947-4) Ui	(V) -	-	-	690	-	-
Rated thermal current I <sub>th</sub>	(A) -	-	-	10	-	-
Operation current						
AC-15 - Ue-Ie	(V - A) -	110/120 - 3 ; 220/240 - 2 ; 380/415 - 1 ; 480/500 - 0.8 ; 660/690 - 0.3	-	-	-	-
DC-13 - Ue-Ie	(V - A) -	24 - 2 ; 48 - 1.4 ; 110 - 0.6 ; 250 - 0.3 ; 440 - 0.1	-	-	-	-
Utilisation according UL and CSA	-	-	-	B600 - Q600	-	-
Protective fuse type gL	(A) -	-	-	10	-	-
Terminal capacity	(mm <sup>2</sup> ) -	-	-	2.5	-	-
Tightening capacity	(Nm) -	-	-	0.8	-	-

Conformity to standards

IEC/EN 60947-4-1	NFC 63-650	NI C 63-650
IEC/EN 60947-5-1	CEI 17-50	VDE 0660
UNE 115	CSA 22.2/14	UL 508

Remote electrical reset

Power consumption		
AC	(VA)	100
DC	(W)	100

Coils not suitable for continuous operating duty

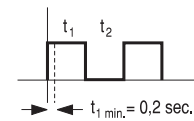

- t<sub>1</sub> = 1 sec.    ♦    t<sub>2</sub> = 30 sec.
  - t<sub>1</sub> = 5 sec.    ♦    t<sub>2</sub> = 90 sec.
  - t<sub>1</sub> = 10 sec.   ♦    t<sub>2</sub> = 180 sec.
- (t<sub>1</sub> = ON time t<sub>2</sub> = OFF time)

Approvals

cULus	RINA	CE
LLoyd's Register	Bureau Veritas	

Ambient conditions

Storage temperature	-40°C to +70°C
Operation temperature (compensated)	-25°C to +60°C
Altitude	up to 3000m
	w/o any changes in characteristics
Relative humidity	98%
Protection treatment	Tropical finish

Mounting positions

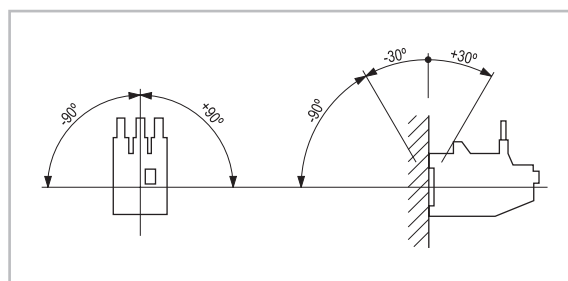



Tripping curves

RT1 Class 10A

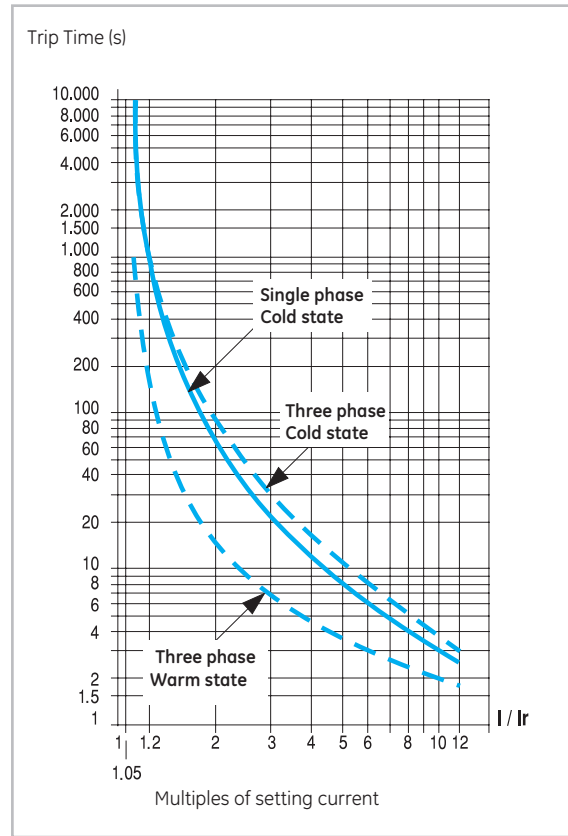

RT2 Class 10

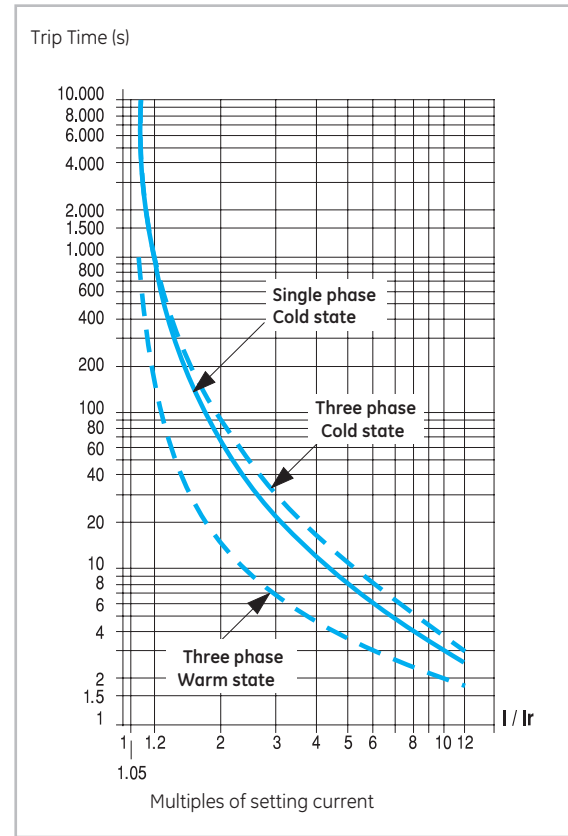

RT12 Class 20

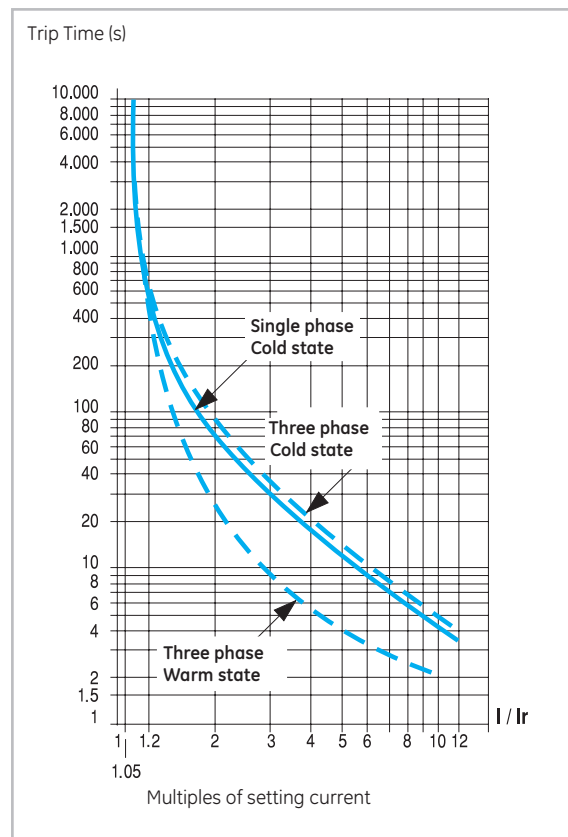

RT22 Class 20

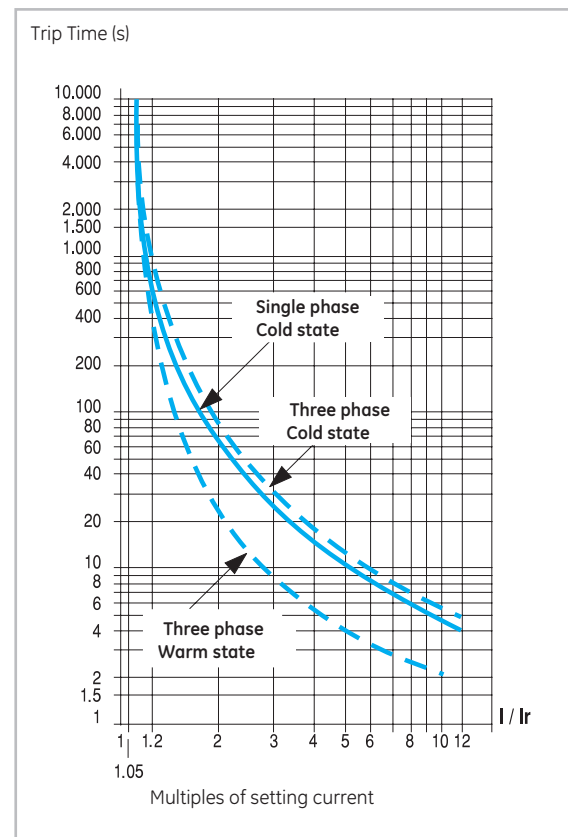

Technical data

Intro

A

B

C

D

E

F

G

H

I

J/X



Tripping curves

RT3 Class 10

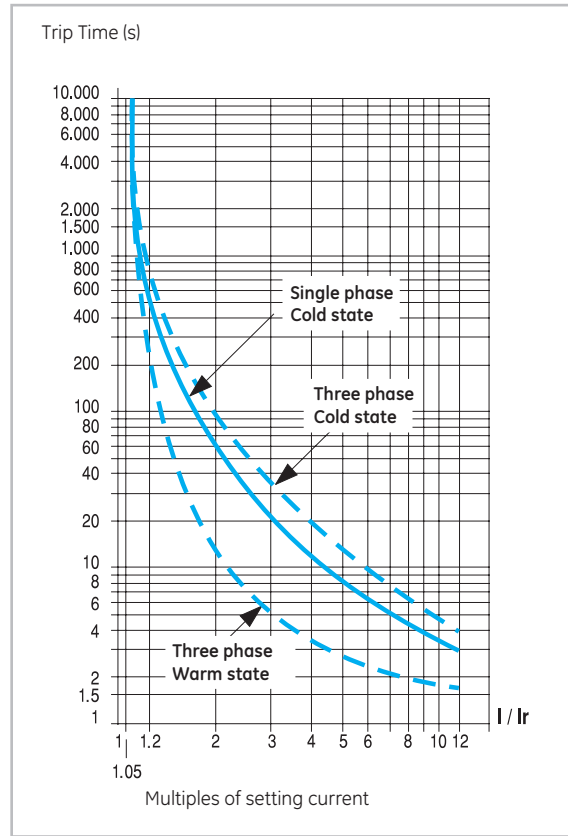

RT4 Class 10

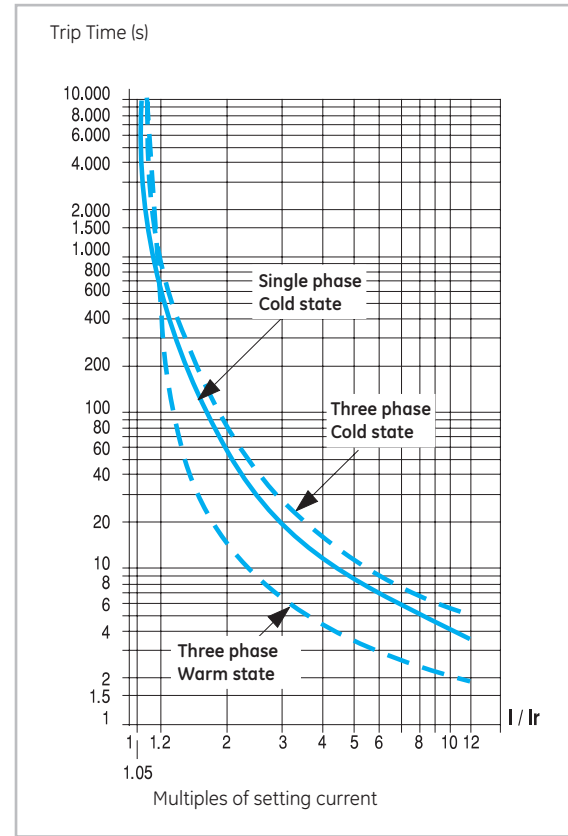

RT32 Class 20

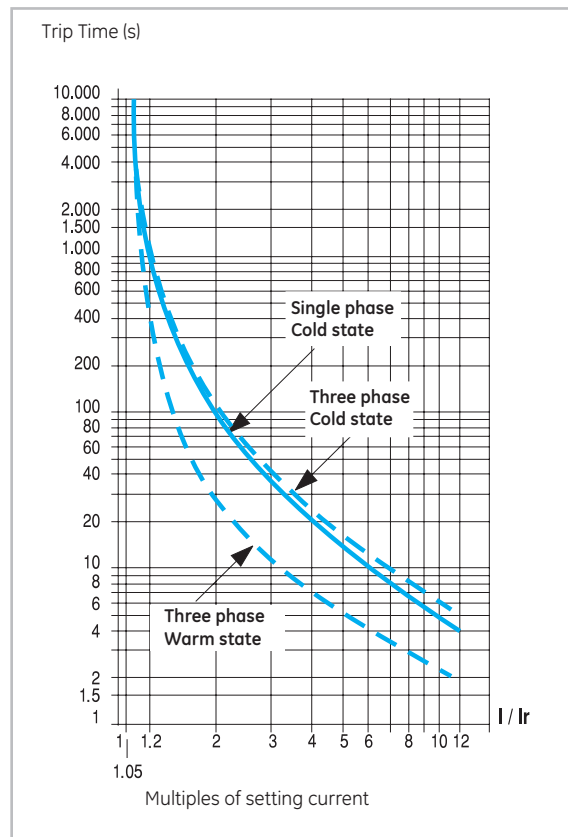

RT4L Class 30

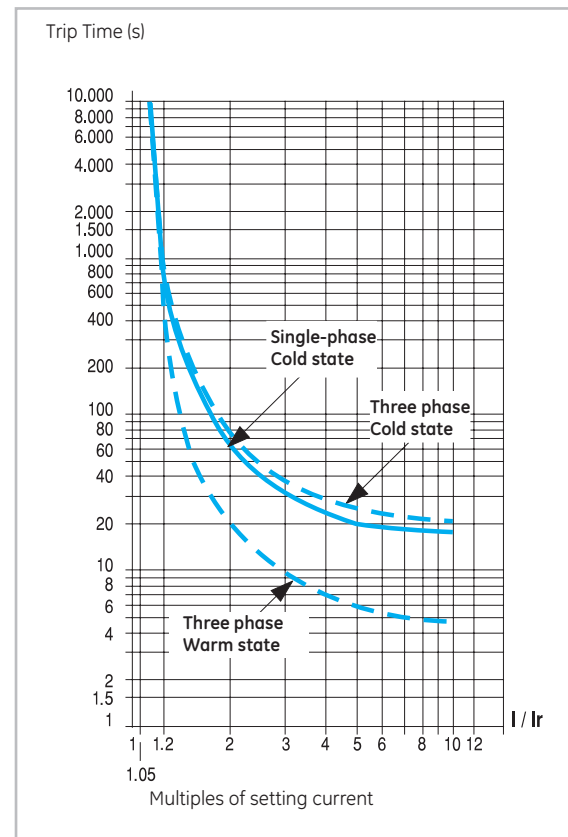

Thermal overload relays  
Intro  
A  
B  
C  
D  
E  
F  
G  
H  
I  
J/X



Tripping curves

RT5 Class 10

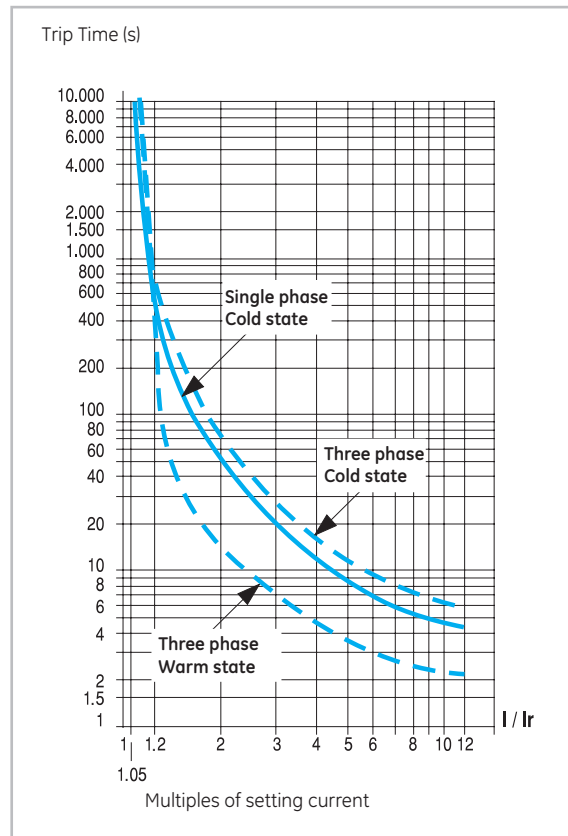

RT6 Class 10

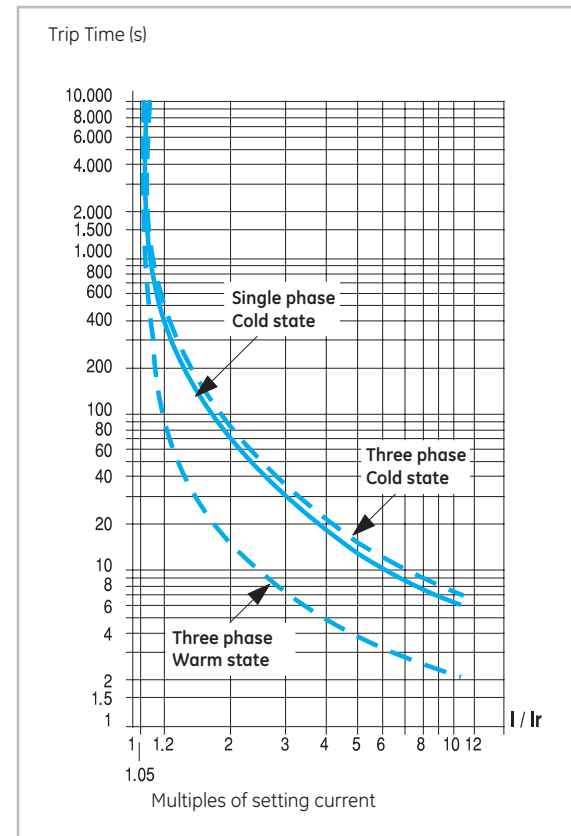

RT5L Class 30

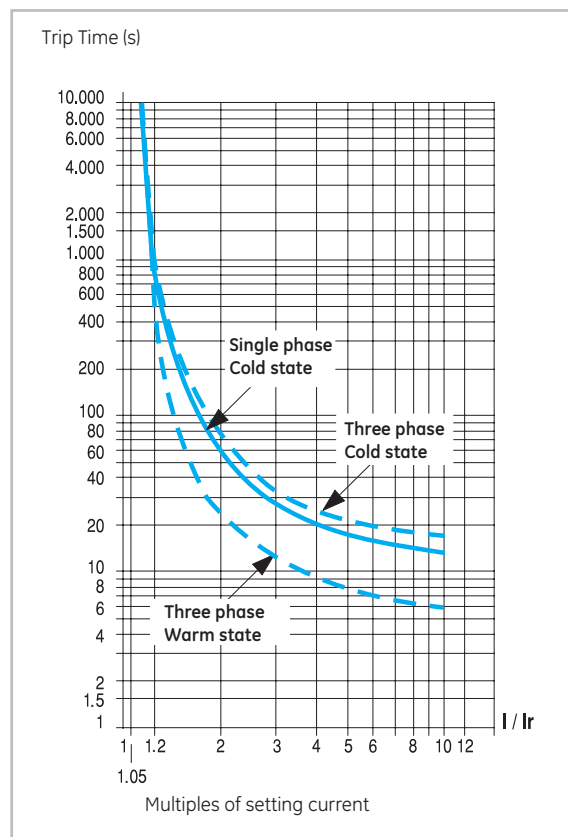

RT6L Class 30

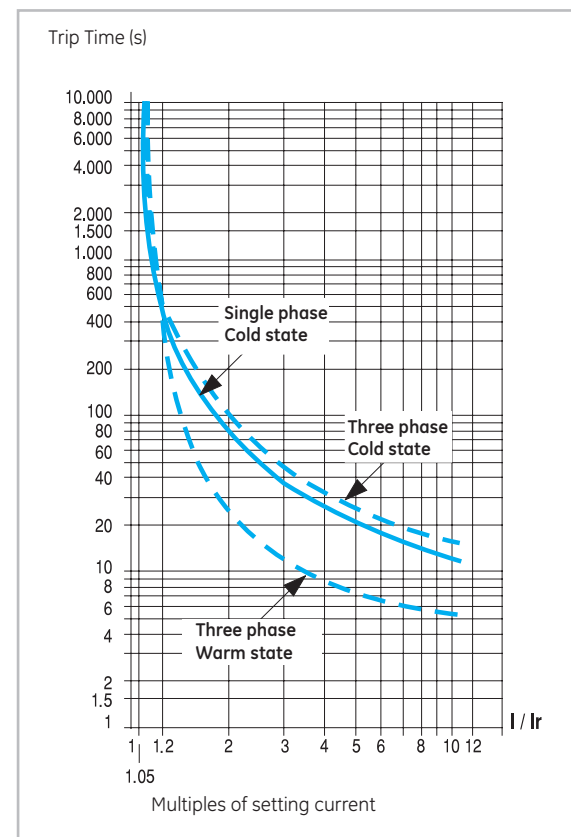

Technical data

Intro

A

B

C

D

E

F

G

H

I

J/X



Dimensional drawings

Thermal overload relay for contactors

RT1 - RT12  
0.190 kg

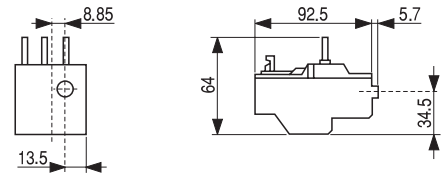

RT1 + RT XP  
RT12 + RTXP

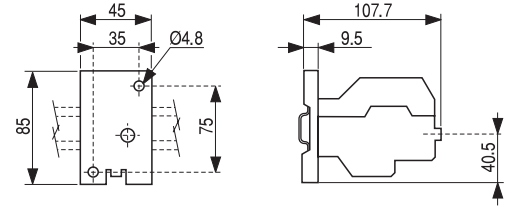

RT2 - RT22  
0.400 kg

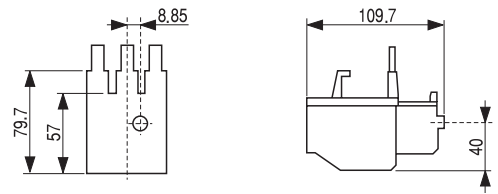

RT2 + RT XP  
RT22 + RTXP

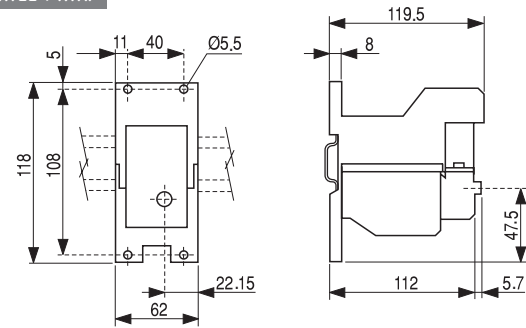

RT3 - RT32  
0.900 kg

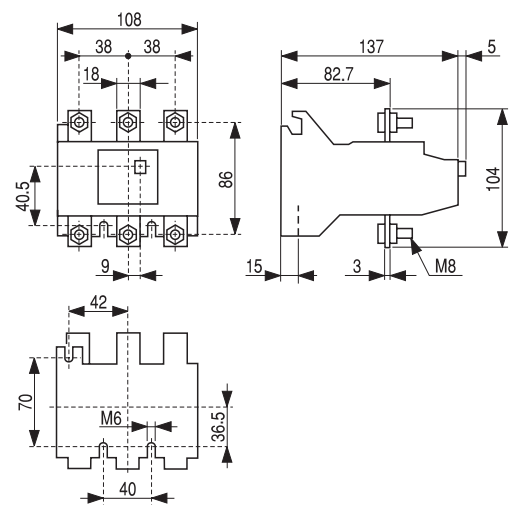

- Thermal overload relays
- Intro
- A
- B
- C
- D
- E
- F
- G
- H
- I
- J/X



Thermal overload relay for contactors

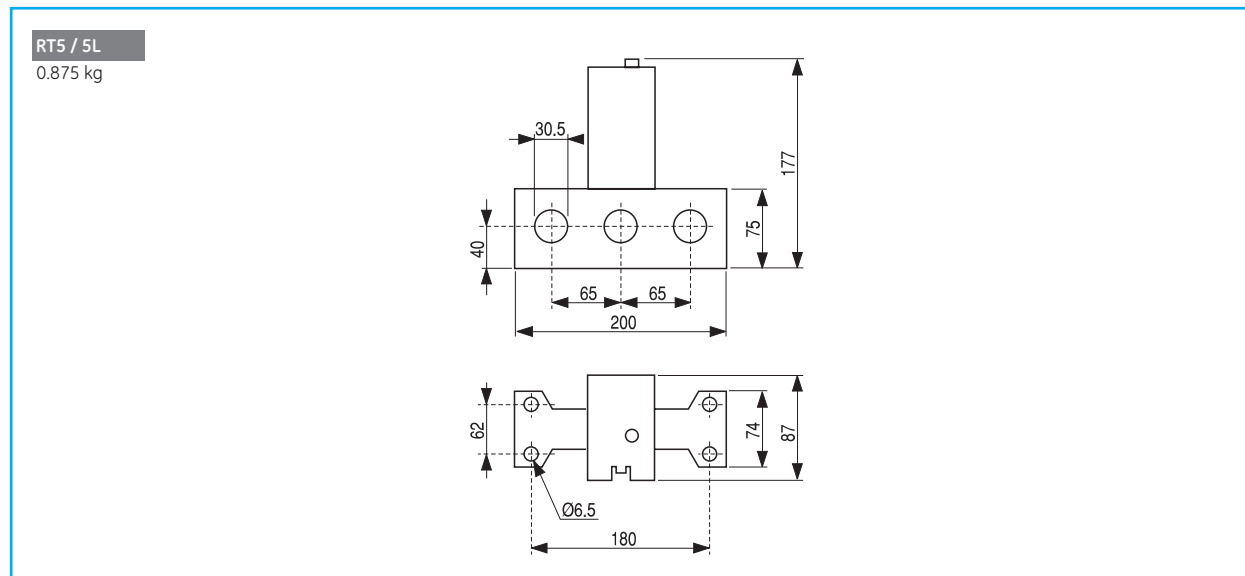
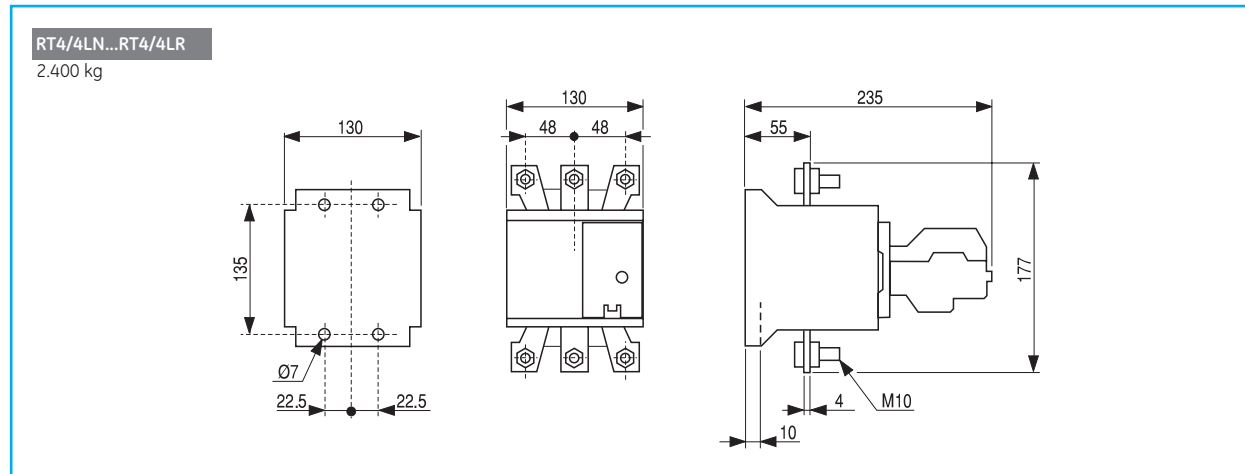
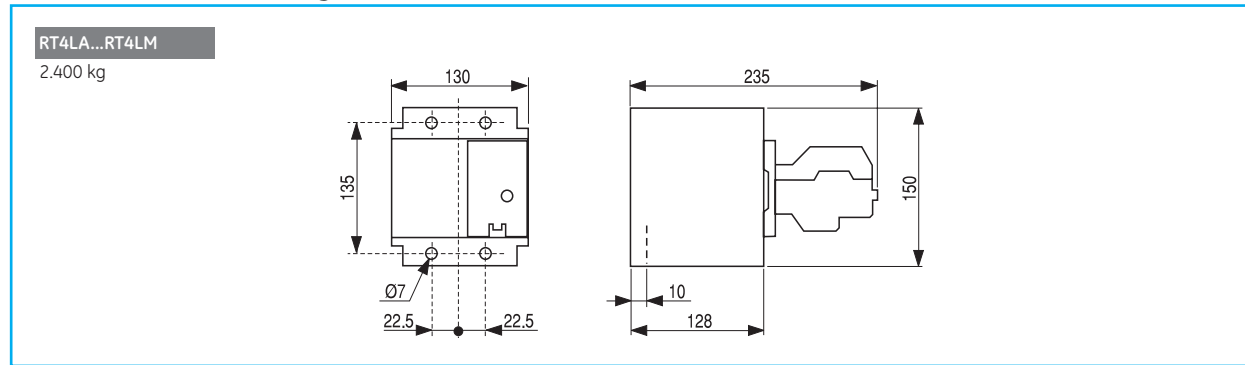

Remote electrical reset

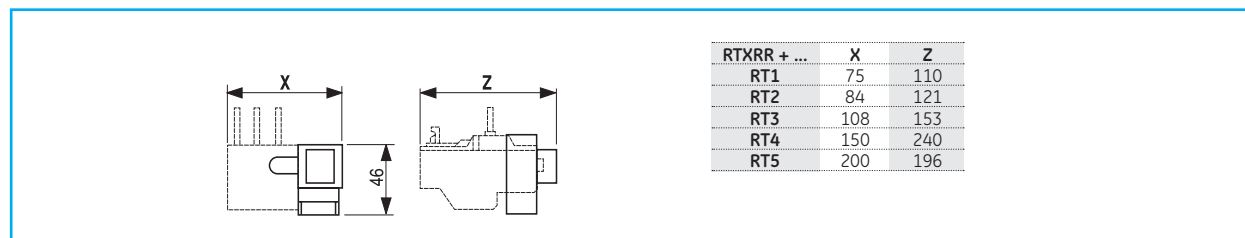

Dimensions

Intro

A

B

C

D

E

F

G

H

I

J/X



Coordination tables

Coordination Type 2 - 65kA at 380/400V and 415V - 50/60Hz

Rated power (kW)	MOTOR <sup>(1)</sup>		Cat. no. #	BREAKER			CONTACTOR Series	OVERLOAD RELAY		WIRE	
	Rated current			Rated current In (A)	Magnetic setting 1m Pick-up ±20% Im (A)	Magnetic current (A)		Series	Setting range (A)	Smallest wire Cu (PVC) <sup>(2)</sup> (mm <sup>2</sup> )	Min frontal safety (mm)
	380/400V (A)	415V (A)									
0.06	0.23	0.21	GPS1MHAB	0.25	-	3.3	CLOO	RE1D	0.1-0.5	1	20
0.09	0.34	0.31	GPS1MHAC	0.4	-	5.2	CLOO	RE1D	0.1-0.5	1	20
0.12	0.44	0.4	GPS1MHAD	0.63	-	8.2	CLOO	RE1D	0.1-0.5	1	20
0.18	0.65	0.63	GPS1MHAE	1	-	13	CLOO	RE1H	0.4-2.0	1	20
0.25	0.9	0.8	GPS1MHAE	1	-	13	CLOO	RE1H	0.4-2.0	1	20
0.37	1.25	1.1	GPS1MHAF	1.6	-	20.8	CLOO	RE1H	0.4-2.0	1	20
0.55	1.6	1.5	GPS1MHAF	1.6	-	20.8	CLOO	RE1H	0.4-2.0	1	20
0.75	2	1.9	GPS1MHAG	2.5	-	32.5	CLOO	RE1K	1.5-5.0	1	20
1.1	2.6	2.5	GPS1MHAH	4	-	52	CL25	RE1K	1.5-5.0	1	20
1.5	3.5	3.4	GPS1MHAH	4	-	52	CL25	RE1K	1.5-5.0	1	20
2.2	5	4.5	GPS1MHAJ	6.3	-	81.9	CL25	RE1K	1.5-5.0	1	20
3	7	6.5	GPS1MHAK	10	-	130	CL25	RE1M	1.6-8.0	1.5	20
4	9	8	GPS1MHAK	10	-	130	CL25	RE1S	6.4-32.0	1.5	20
5.5	12	11	GPS1MHAL	13	-	169	CL25	RE1S	6.4-32.0	2.5	20
7.5	-	14	GPS1MHAM	16	-	208	CL25	RE1S	6.4-32.0	2.5	20
8.8	16	-	GPS1MHAM	16	-	208	CL25	RE1S	6.4-32.0	2.5	20
11	22.5	21	GPS1MHAP	25	-	325	CL25	RE1S	6.4-32.0	4	20
15	30	28	GPS1MHAR	32	-	416	CL04	RE1S	6.4-32.0	6	20
11	22.5	21	GPS2MHAR	25	-	325	CL04	RE1S	6.4-32.0	4	20
15	30	28	GPS2MHAP	32	-	416	CL04	RE1S	6.4-32.0	6	20
18.5	37	35	GPS2MHAS	40	-	520	CL45	RE1W	9.0-45.0	10	20
22	-	40	GPS2MHAT	50	-	650	CL06	RE2H	15.0-75.0	10	25
-	44	--	GPS2MHAT	50	-	650	CL06	RE2H	15.0-75.0	10	25
30	60	55	GPS2MHAU	63	-	819	CL07	RE2H	15.0-75.0	16	25
35	65	60	FDH36MC080GD	80	900-1300	1100	CL08	RE2H	15.0-75.0	25	25
45	85	80	FDH36MC1 OOGD	100	1000-1500	1400	CL09	RE2M	22.0-110.0	25	30
55	-	100	FDH36MC1 OOGD	100	1000-1500	1400	CL10	RE2M	22.0-110.0	25	30
55	105	-	FEH36MC125JF	125	1250-1875	1250	CL10	RE2M	22.0-110.0	25	30
75	138	135	FEH36MC200KF	200	2250-3350	2800	CK75	RE3E	30.0-150.0	50	40

Coordination Type 2 - 100kA at 500 - 525V - 50/60Hz

Rated power kW	MOTOR <sup>(1)</sup>		gL/g Fuses		EOL			CONTACTOR		WIRE	
	Rated current 500V (A)	525V (A)	In (A)	Size	Series	Type	Setting range (A)	Series	PAC3 (kW)	Seco min	Safety clearance (mm)
0.06	0.17	0.16	2	000	RE1	D	0.1-0.5	CLOO	5.5	1	20
0.03	0.24	0.22	2	000	RE1	D	0.1-0.5	CLOO	5.5	1	20
0.12	0.33	0.3	2	000	RE1	D	0.1-0.5	CLOO	5.5	1	20
0.18	0.48	0.46	2	000	RE1	D	0.1-0.5	CLOO	5.5	1	20
0.25	0.66	0.64	2	000	RE1	H	0.4-2.0	CLOO	5.5	1	20
0.37	0.3	0.85	4	000	RE1	H	0.4-2.0	CLOO	5.5	1	20
0.55	1.2	1.15	4	000	RE1	H	0.4-2.0	CLOO	5.5	1	20
0.75	1.5	1.45	4	000	RE1	H	0.4-2.0	CLOO	5.5	1	20
1.1	2.1	1.3	6	000	RE1	K	1.5-5.0	CLOO	5.5	1	20
1.5	2.8	2.6	10	000	RE1	K	1.5-5.0	CLOO	5.5	1	20
1.1	2.1	1.3	6	000	RE1	K	1.5-5.0	CL01	7.5	1	20
1.5	2.8	2.6	10	000	RE1	K	1.5-5.0	CL01	7.5	1	20
2.2	3.3	3.6	10	000	RE1	K	1.5-5.0	CL01	7.5	1	20
1.5	2.8	2.6	10	000	RE1	K	1.5-5.0	CL25	15	1	20
2.2	3.3	3.6	10	000	RE1	K	1.5-5.0	CL25	15	1	20
3	5.3	5	16	000	RE1	M	1.6-8.0	CL25	15	1	20
4	6.8	6.5	20	000	RE1	M	1.6-8.0	CL25	15	1	20
5.5	3.1	8.6	25	000	RE1	S	6.4-32.0	CL25	15	1.5	20
7.5	12	11.4	32	000	RE1	S	6.4-32.0	CL25	15	2.5	20
10	15.5	14.8	40	000	RE1	S	6.4-32.0	CL25	15	2.5	20
11	17.6	17	40	000	RE1	S	6.4-32.0	CL25	15	2.5	20
15	23	22	50	000	RE1	S	6.4-32.0	CL04	18.5	4	20
18.5	28.5	27	63	000	RE1	S	6.4-32.0	CL04	18.5	6	20
4	6.8	6.5	20	000	RE1	M	1.6-8.0	CL45	25	1.5	20
5.5	3.1	8.6	25	000	RE1	S	6.4-32.0	CL45	25	2.5	20
7.5	12	11.4	32	000	RE1	S	6.4-32.0	CL45	25	2.5	20
11	17.6	17	40	000	RE1	S	6.4-32.0	CL45	25	2.5	20
15	23	22	50	000	RE1	S	6.4-32.0	CL45	25	4	20
18.5	28.5	27	63	000	RE1	W	3.0-45.0	CL45	25	5	20
22	33	31.5	80	000	RE1	H	15.0-75.0	CL45	25	5	20
18.5	28.5	27	63	000	RE2	H	15.0-75.0	CL06	30	5	25
22	33	31.5	80	000	RE2	H	15.0-75.0	CL06	30	5	25
30	45	43	80	000	RE2	H	15.0-75.0	CL06	30	10	25
37	53	52	100	000	RE2	H	15.0-75.0	CL07	40	10	25
40	53	56	100	000	RE2	H	15.0-75.0	CL08	45	16	25
45	65	62	125	00	RE2	H	15.0-75.0	CL09	55	16	30
55	80	76	125	00	RE2	M	22.0-110.0	CL10	65	25	30
75	105	100	160	01/1	RE3	E	30.0-150.0	CK75	100	35/25	40
30	130	124	250	01/1	RE3	E	30.0-150.0	CK08	110	50	40

(1) Current are relevant to four pole motors not having special characteristics of torque.  
 (2) The minimum cycle cross-sections are referred to an ambient temperature of 30°C max. in free air and are selected to withstand the maximum let-through energy and the motor rated current. Besides the user has to consider the drop voltage, the type of laying and ambient temperature if it is different.



Tripping curves

Class 5

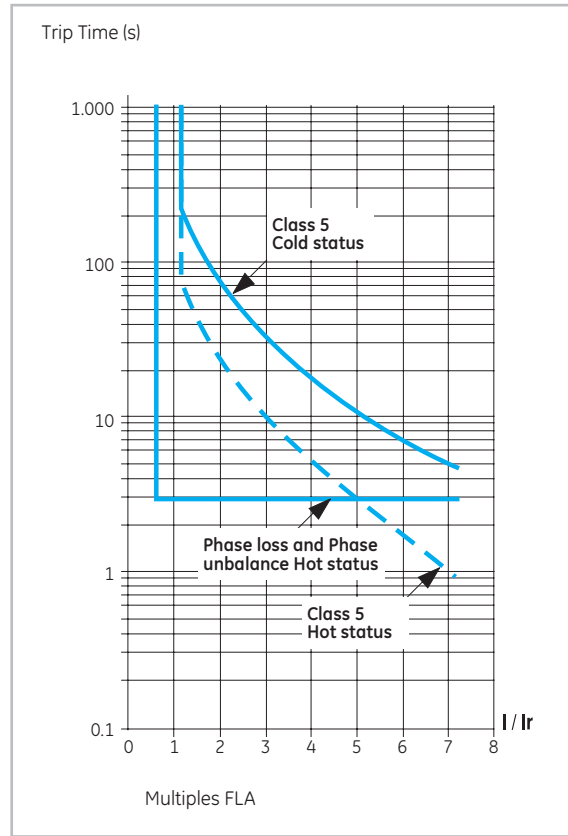

Class 10

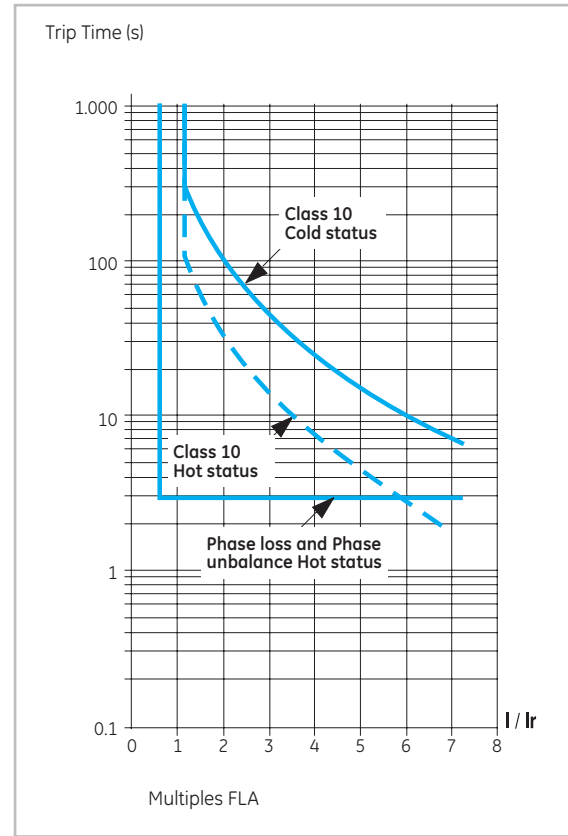

Class 20

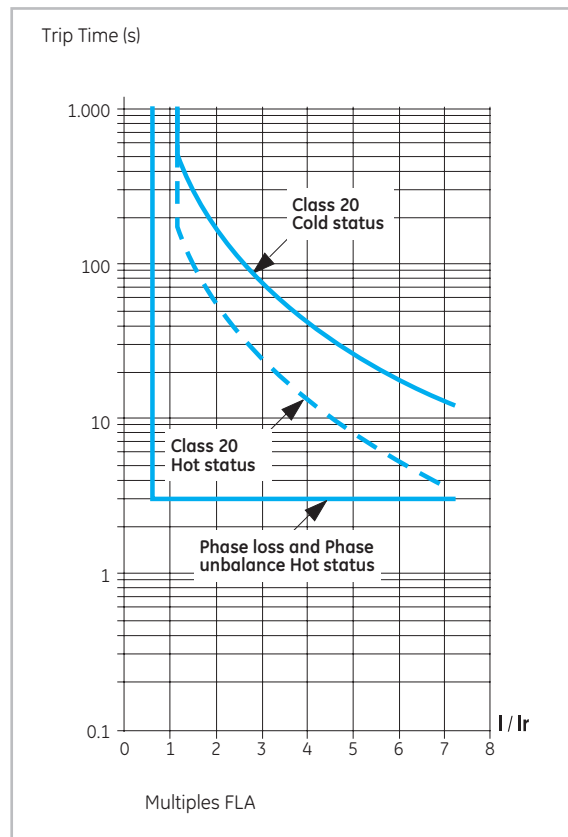

Class 30

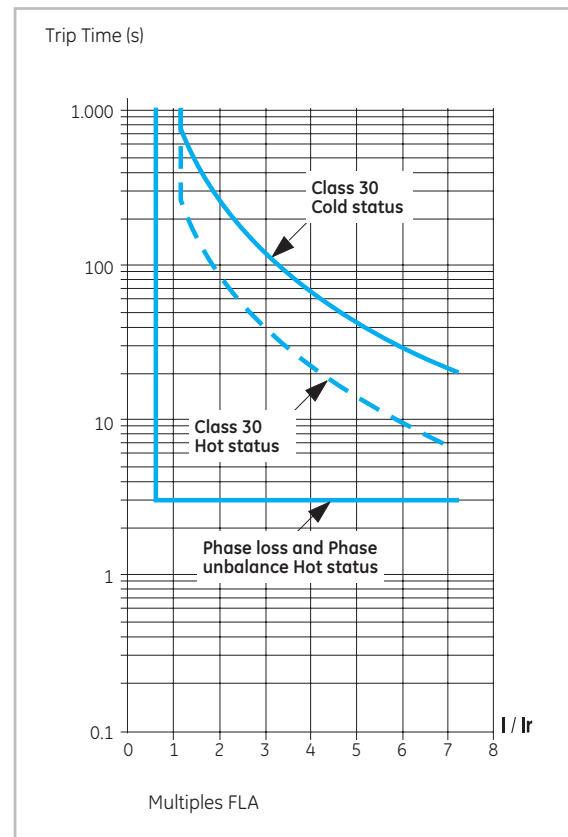

Technical data

Intro

**A**

B

C

D

E

F

G

H

I

J/X



Dimensional drawings

Frame 1

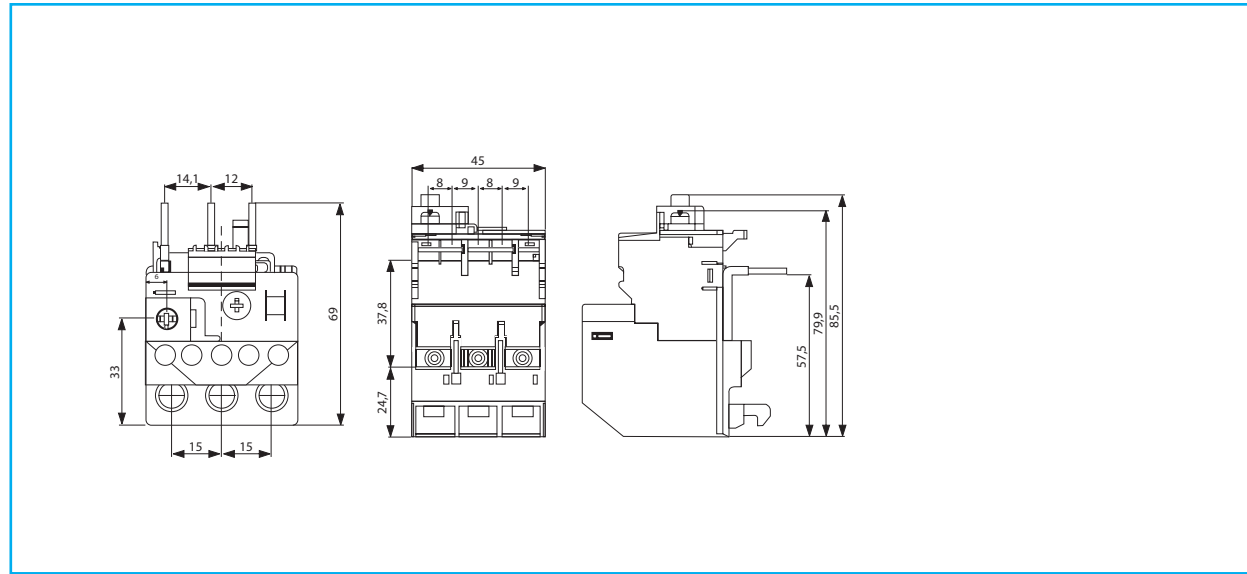

Frame 2

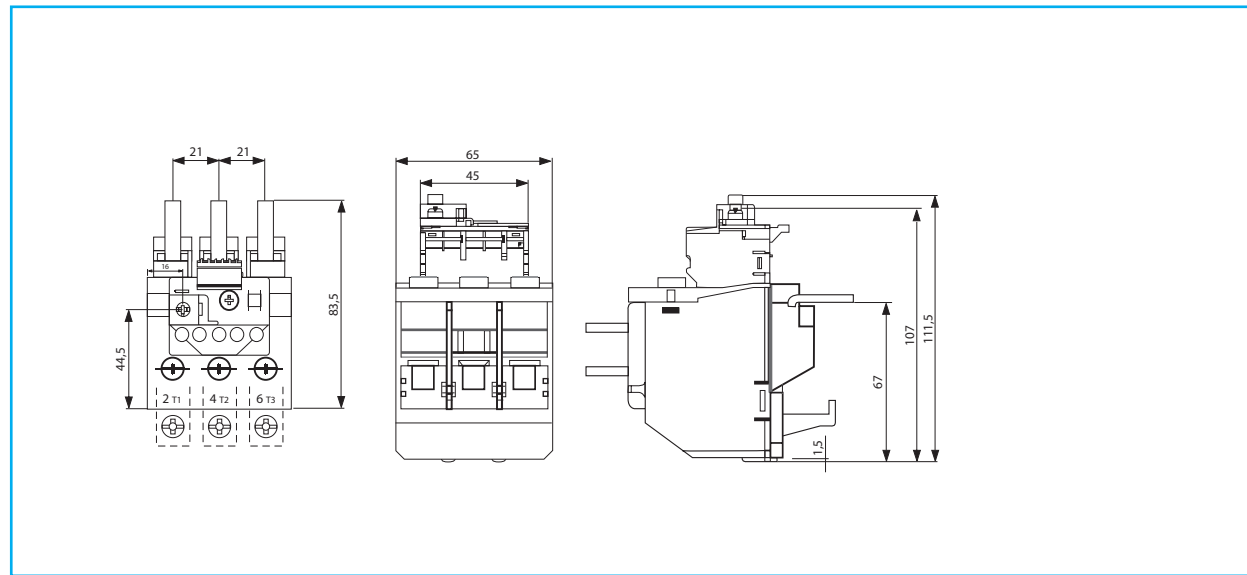

Frame 3

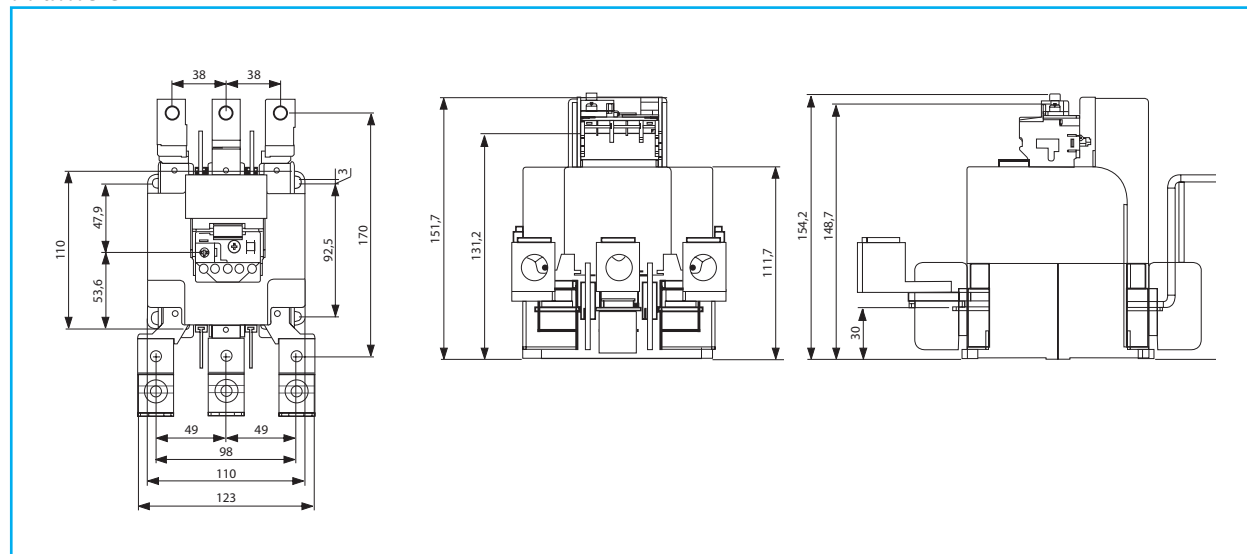

- Electronic overload relays
- Intro
- A
- B
- C
- D
- E
- F
- G
- H
- I
- J/X







Wiring diagrams

Series M. Direct-on-line starter with reset

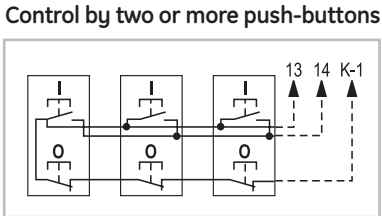
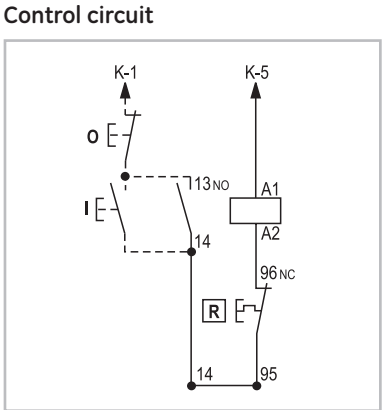
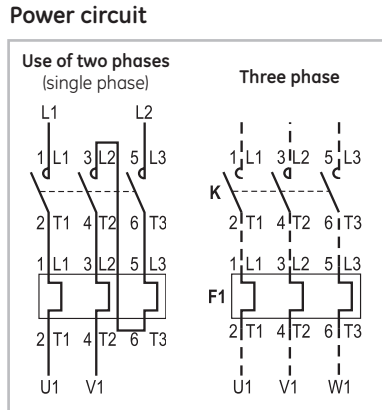

Series M. Direct-on-line starter with start/emergency stop push-button

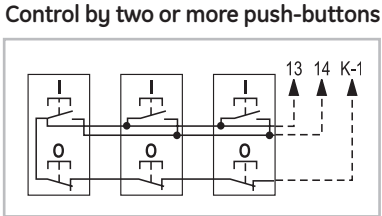
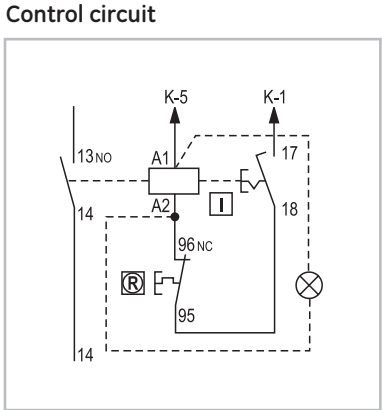
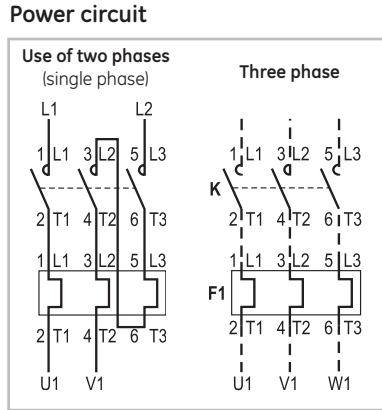

Wiring diagrams

Intro

A

B

C

D

E

F

G

H

I

J/X



Wiring diagrams

Series CL. Direct-on-line starter

Power circuit

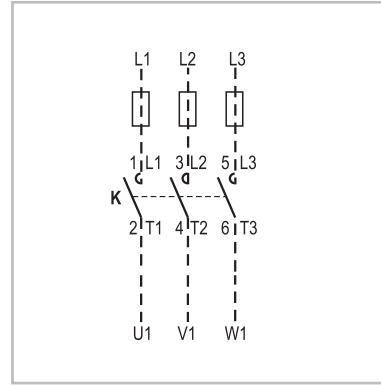

Control circuit

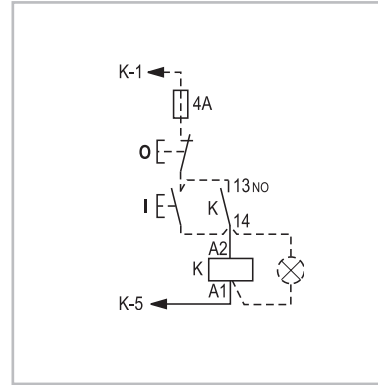

Control by two or more push-buttons

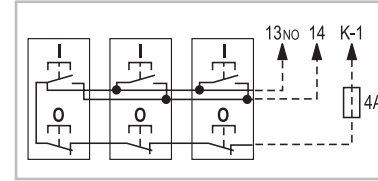

Control by permanent contact

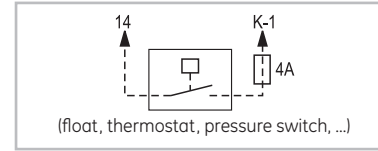

Series CL. Direct-on-line starter with reset push-button

Power circuit

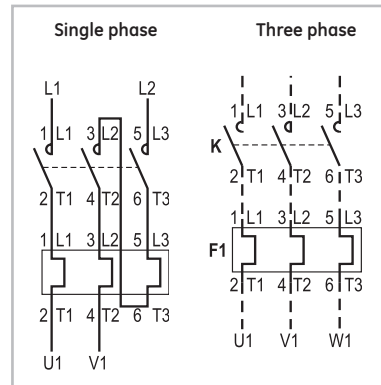

Control circuit

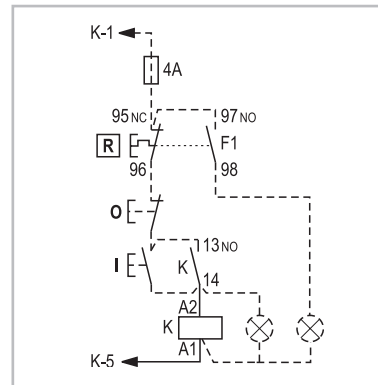

Control by two or more push-buttons

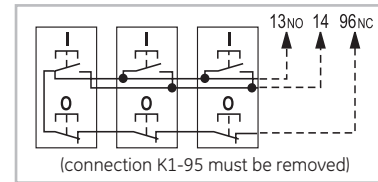

Control by permanent contact

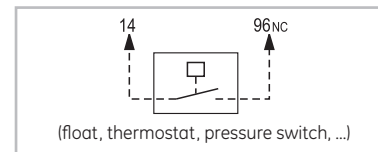

Series CL. Direct-on-line starter with start/stop/reset push-button

Power circuit

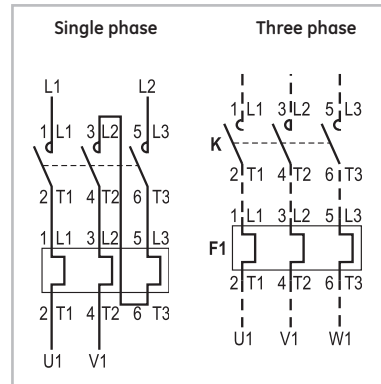

Control circuit

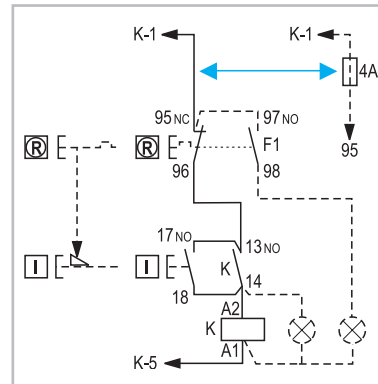

Control by two or more push-buttons

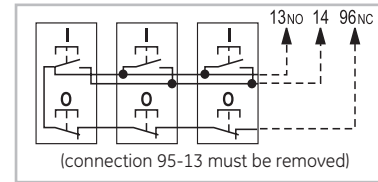

Control by permanent contact

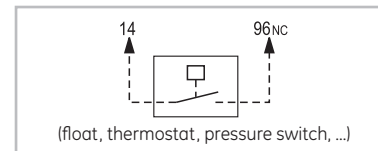

Motorstarters  
Intro  
A  
B  
C  
D  
E  
F  
G  
H  
I  
J/X



Series CK. Direct-on-line starter

Power circuit

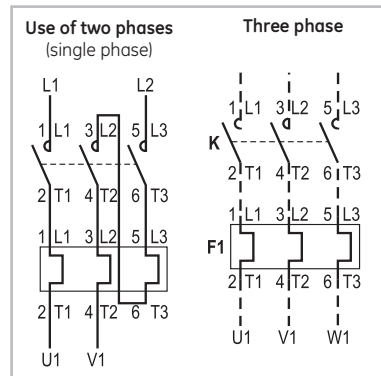

Control circuit

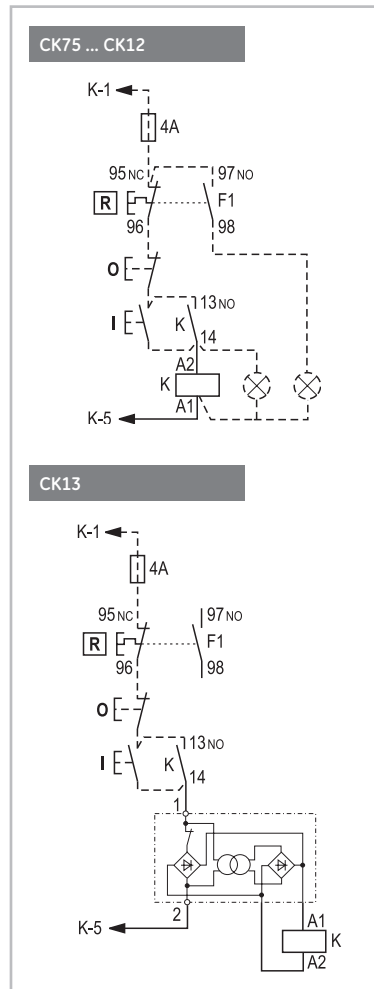

Control by two or more push-buttons

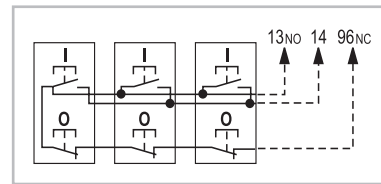

Control by permanent contact

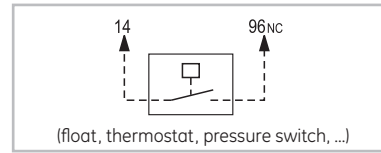

Wiring diagrams

Intro

A

B

C

D

E

F

G

H

I

J/X



Wiring diagrams

Series M. Reversing starter without thermal overload relay

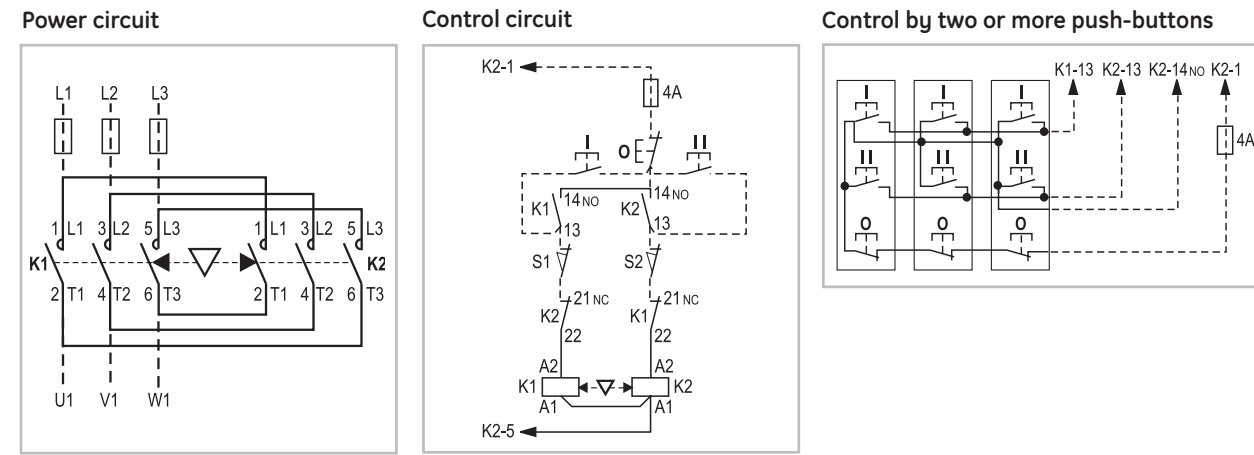

Series CL. Reversing starter without thermal overload relay

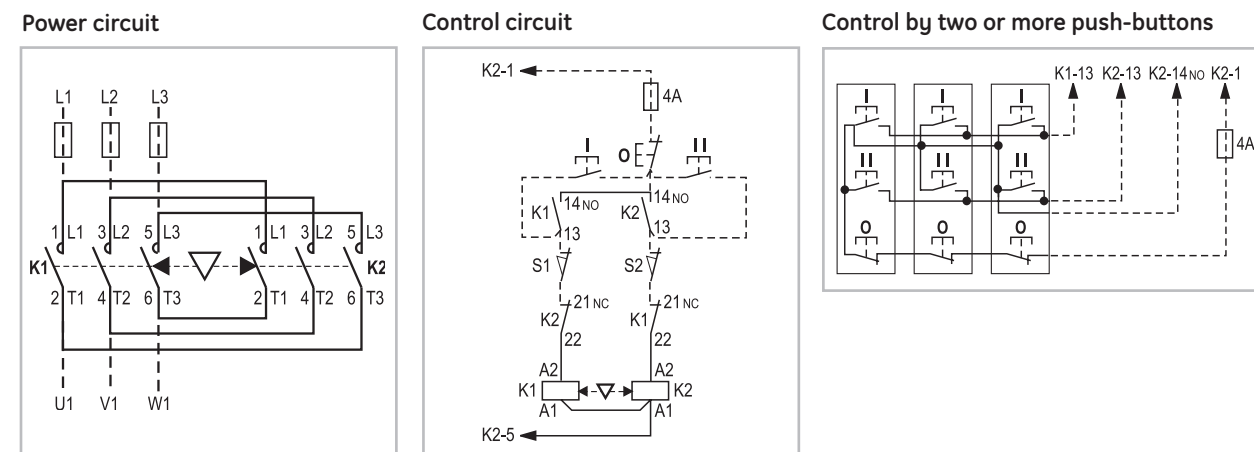

Series CL. Reversing starter with thermal overload relay

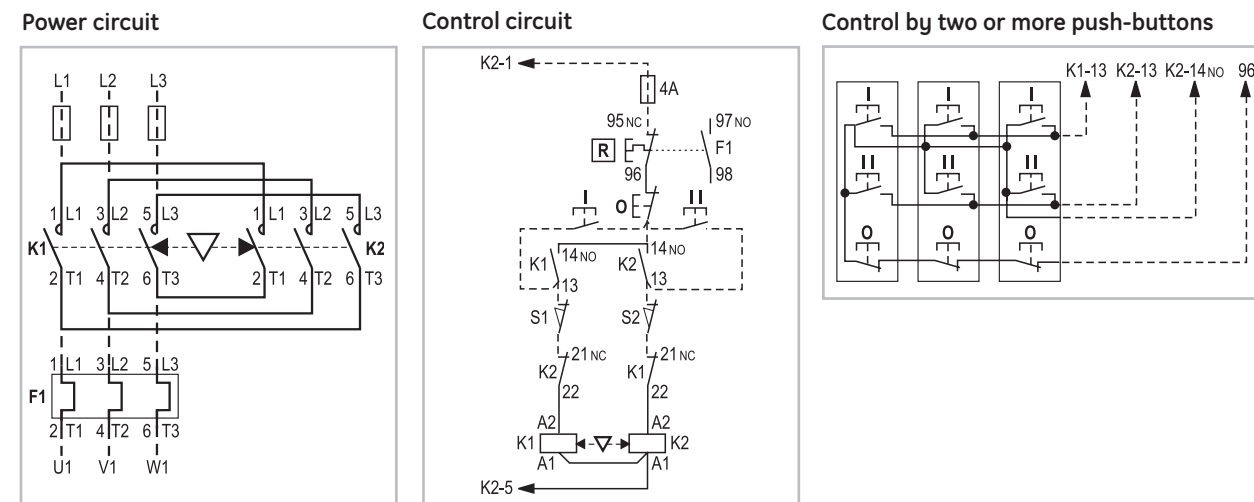

Series CK. Reversing starter without thermal overload relay

Power circuit

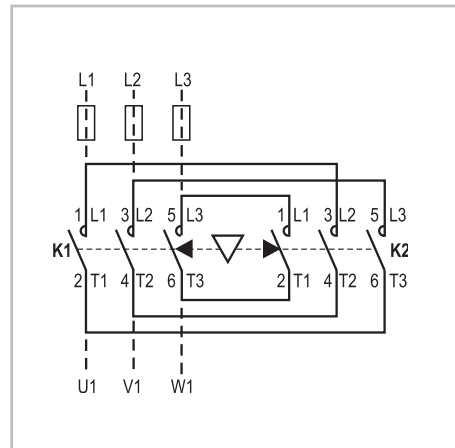

Control by two or more push-buttons

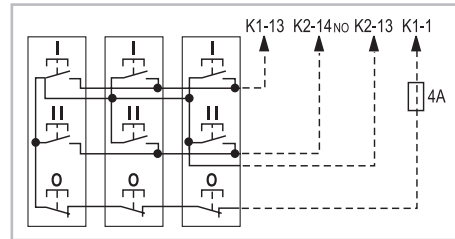

Control circuit

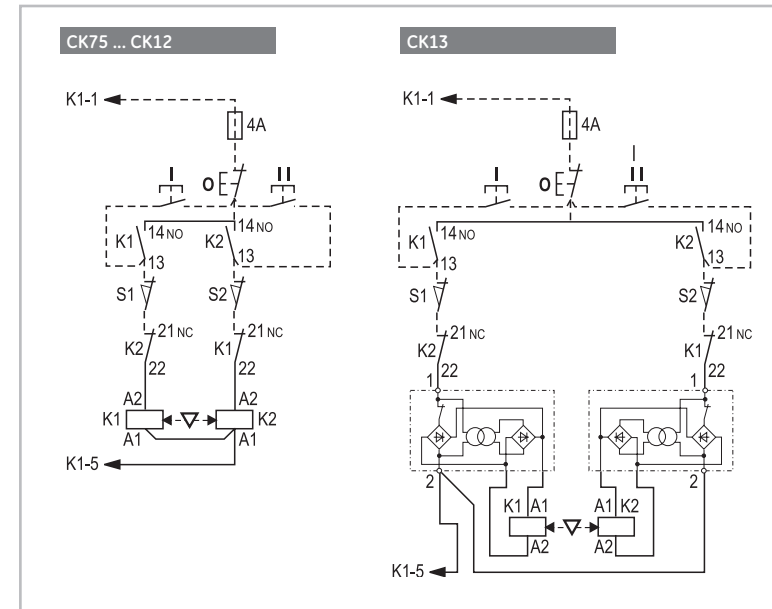

Series CK. Direct-on-line starters with thermal overload relay

Power circuit

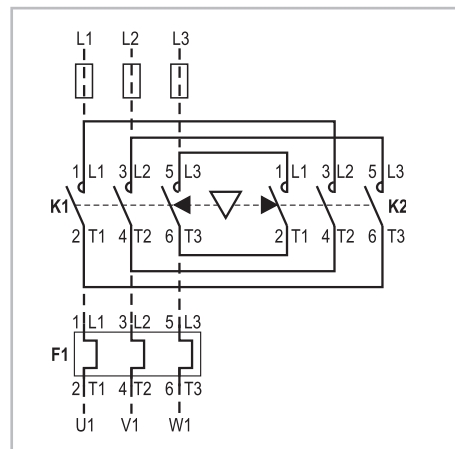

Control by two or more push-buttons

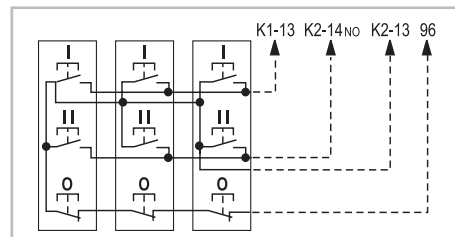

Control circuit

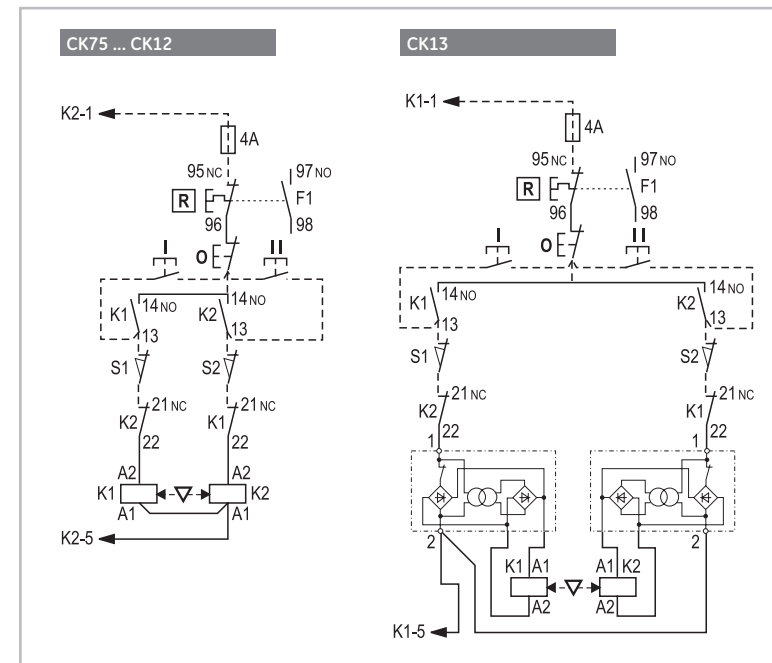

Wiring diagrams

Intro

A

B

C

D

E

F

G

H

I

J/X



Wiring diagrams

Series CL and CK. Star-delta starters

Power circuit

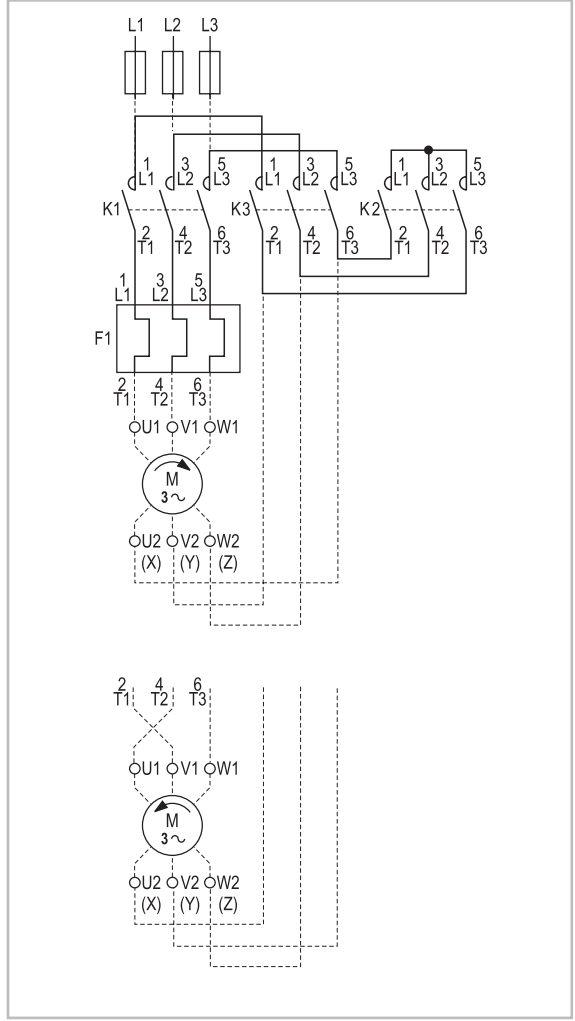

Control circuit

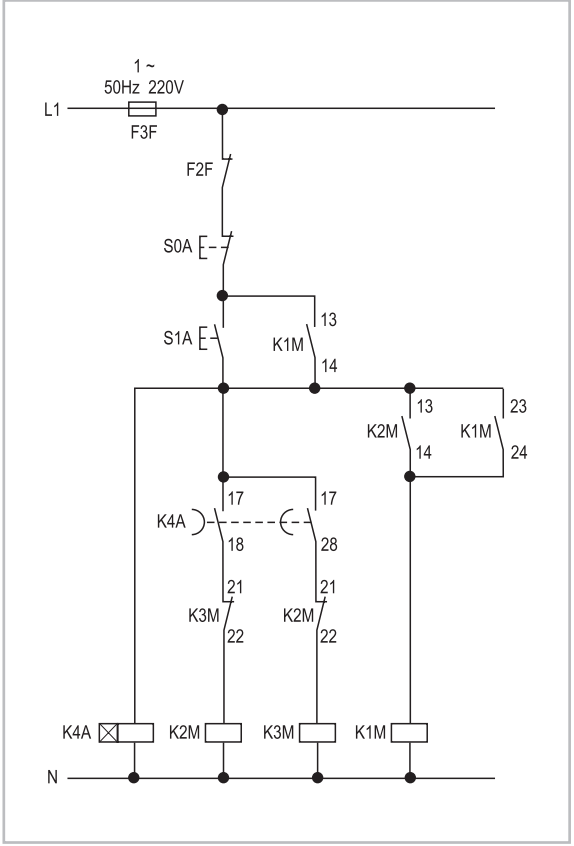

Motorstarters

Intro

A

B

C

D

E

F

G

H

I

J/X



Dimensional drawings

Direct-on-line starters. IP40 / IP65

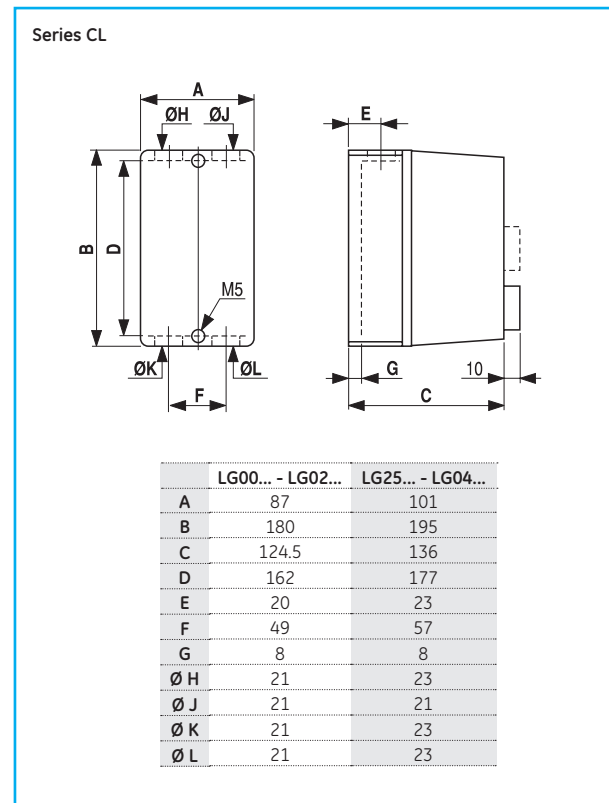
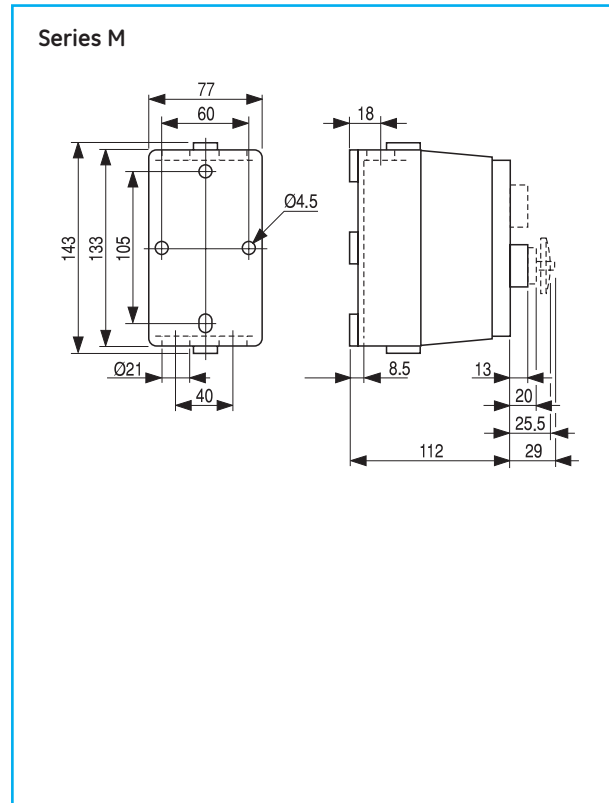

Series CL - Direct-on-line starters

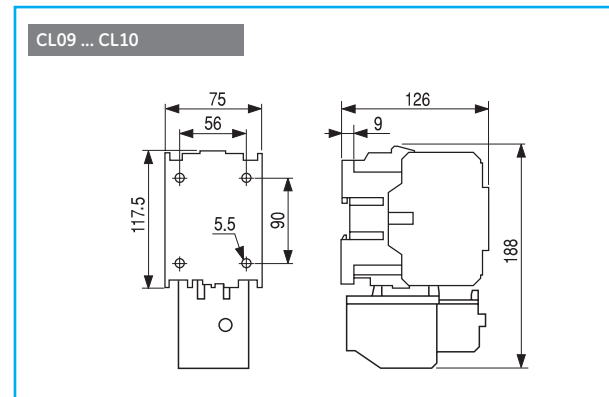
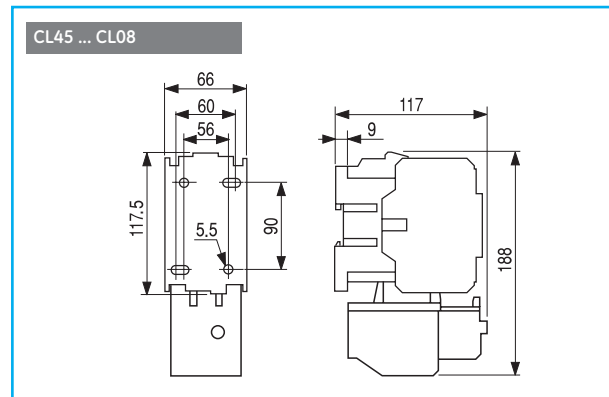
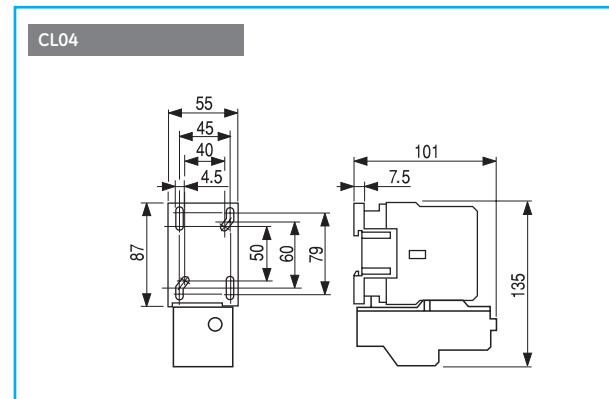
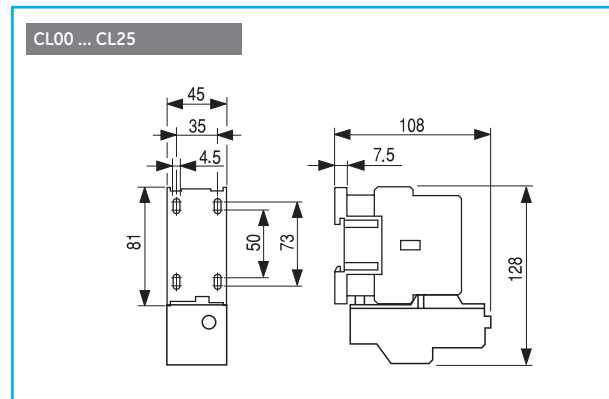

Dimensions

Intro

A

B

C

D

E

F

G

H

I

J/X



Dimensional drawings

Series CK - Direct-on-line starters

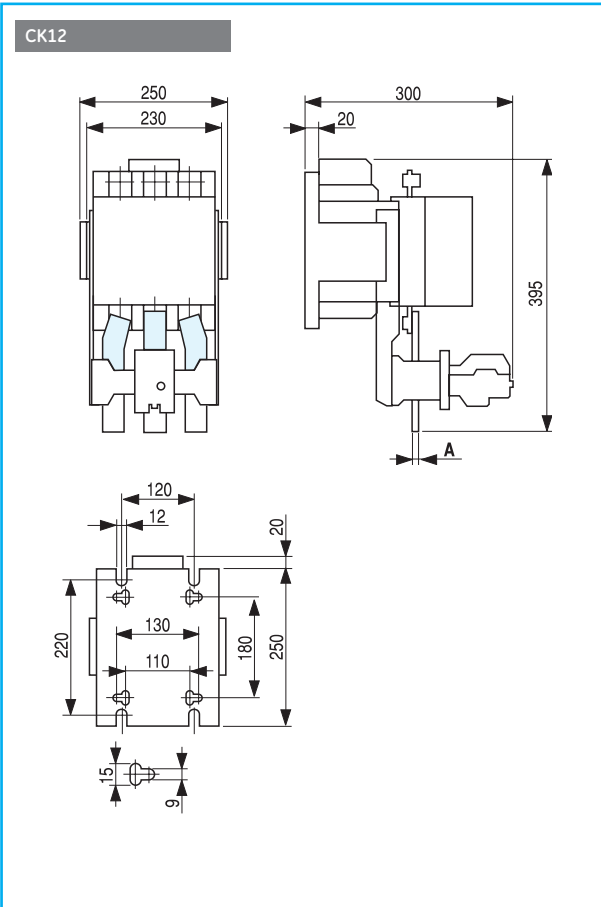
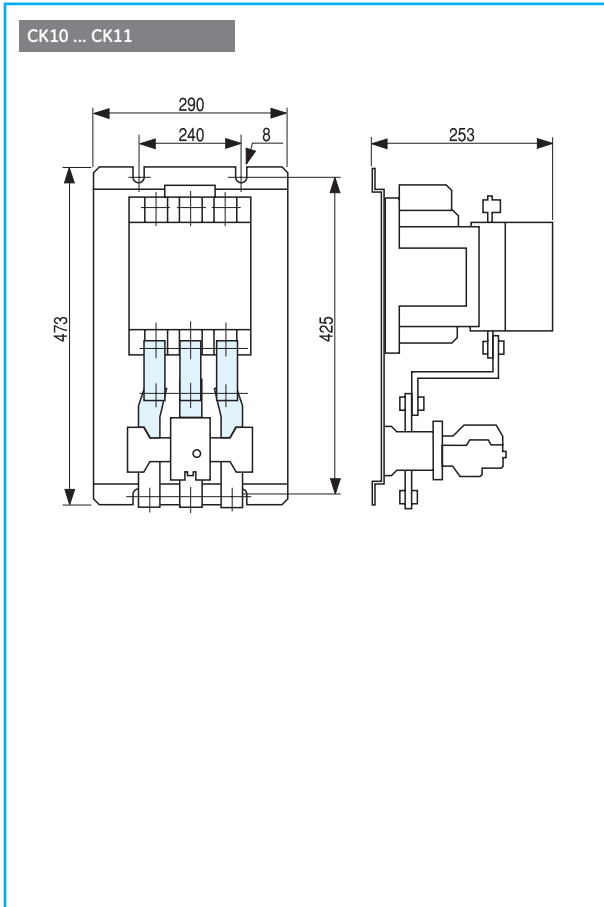
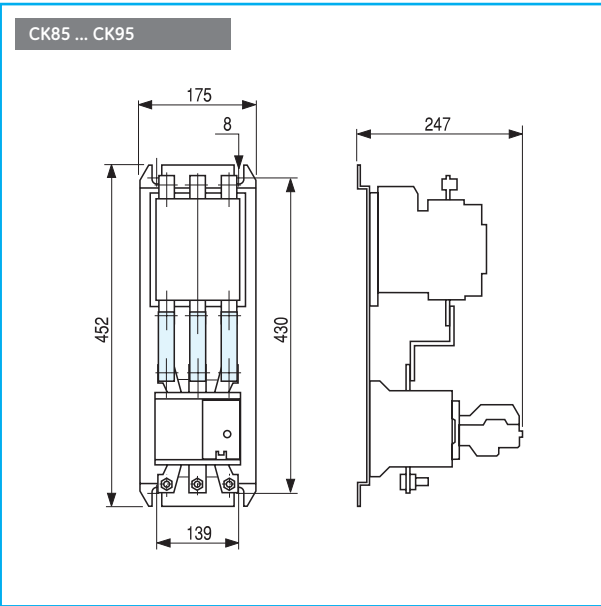
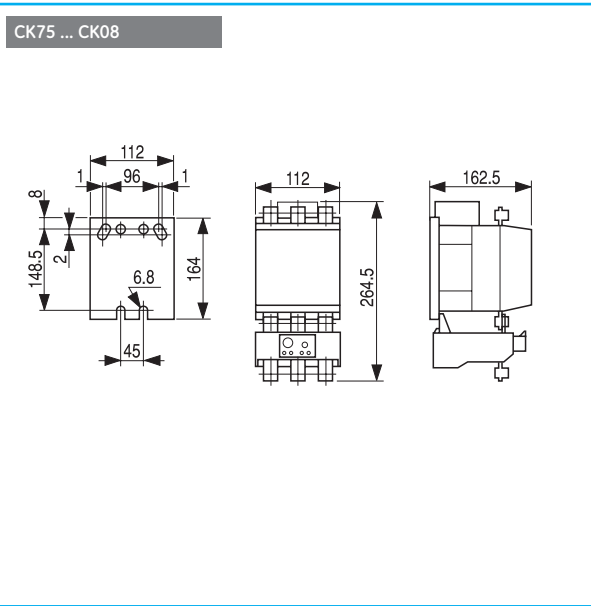

Motorstarters

Intro

A

B

C

D

E

F

G

H

I

J/X





Series M. Direct-on-line reversing starters

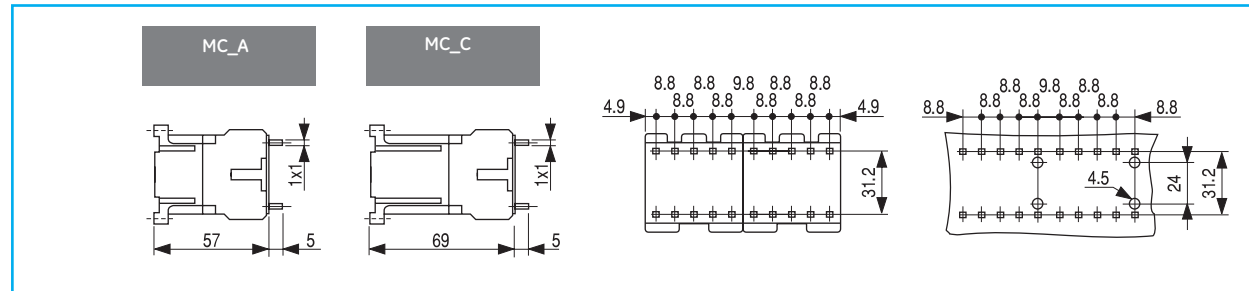
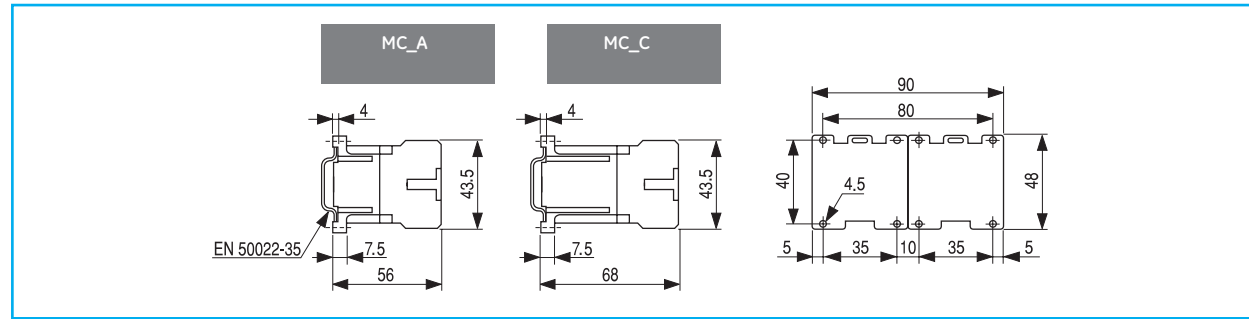

Series CL. Direct-on-line reversing starters without thermal overload relay

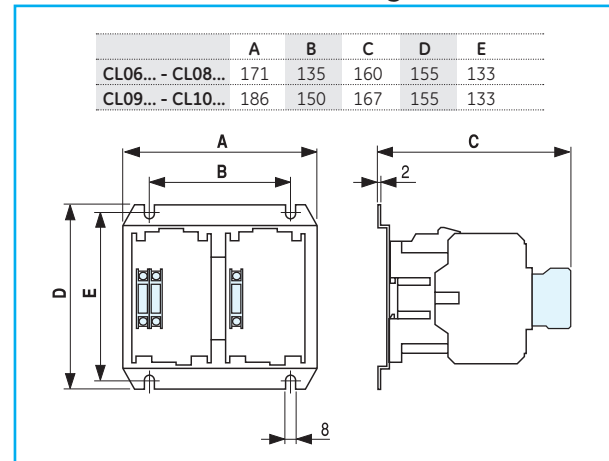
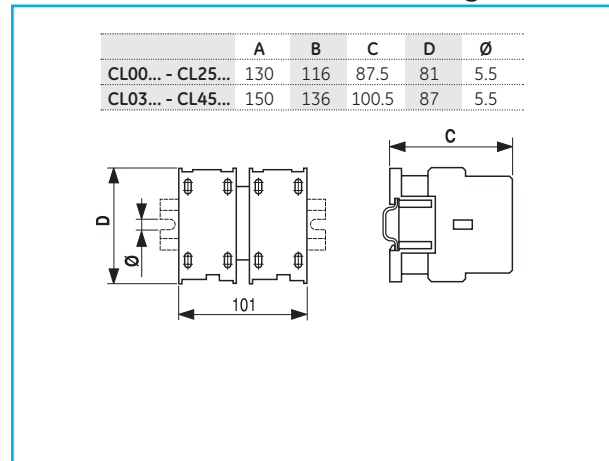

Series CL. Direct-on-line reversing starters with thermal overload relay

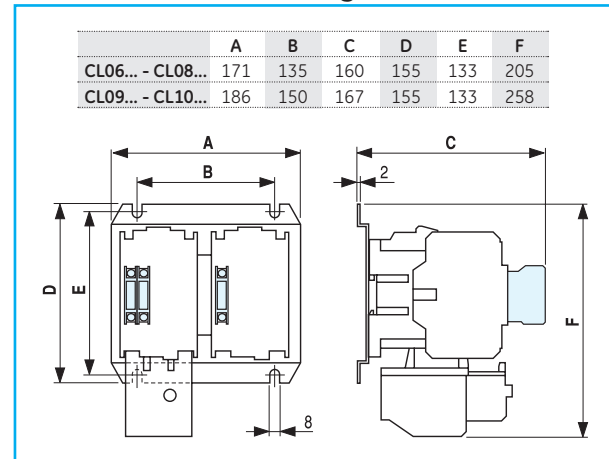
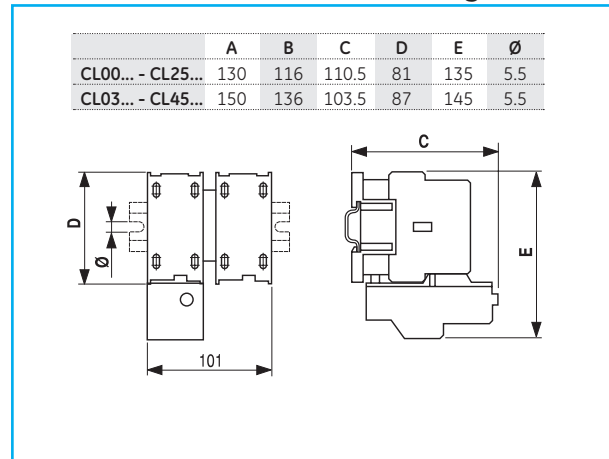

Dimensions

Intro

A

B

C

D

E

F

G

H

I

J/X



Dimensional drawings

Series CK. Direct-on-line reversing starters without thermal overload relay

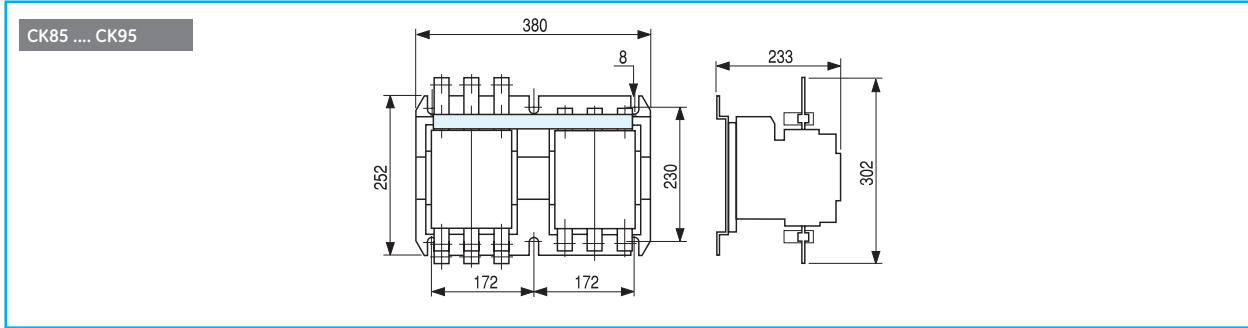
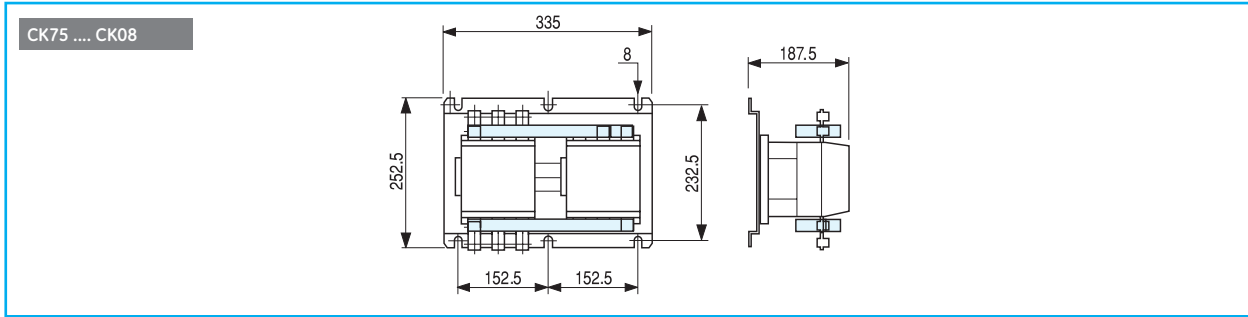

Series CK. Direct-on-line reversing starters with thermal overload relay

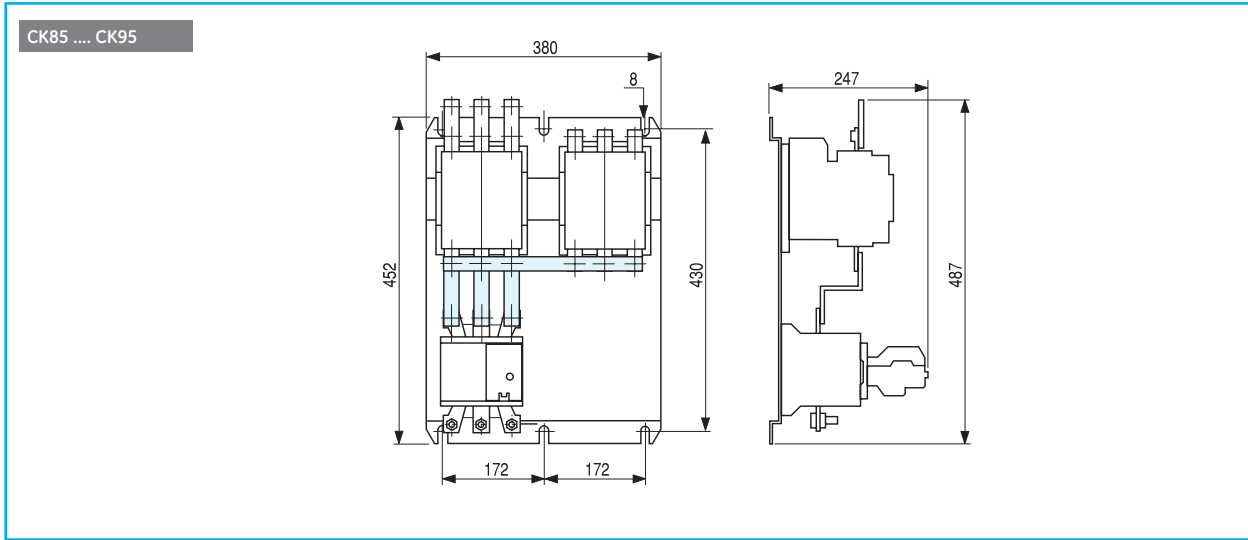
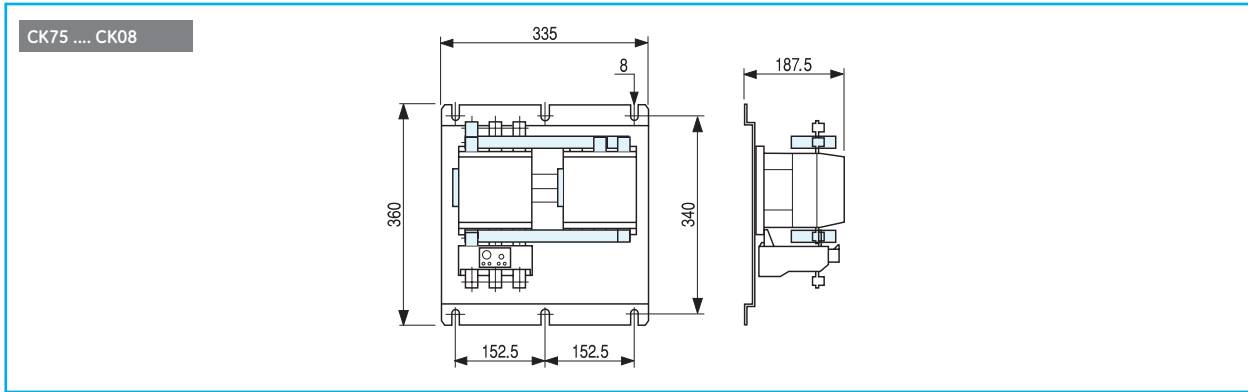

Series CK - Direct-on-line reversing starters without thermal overload relay

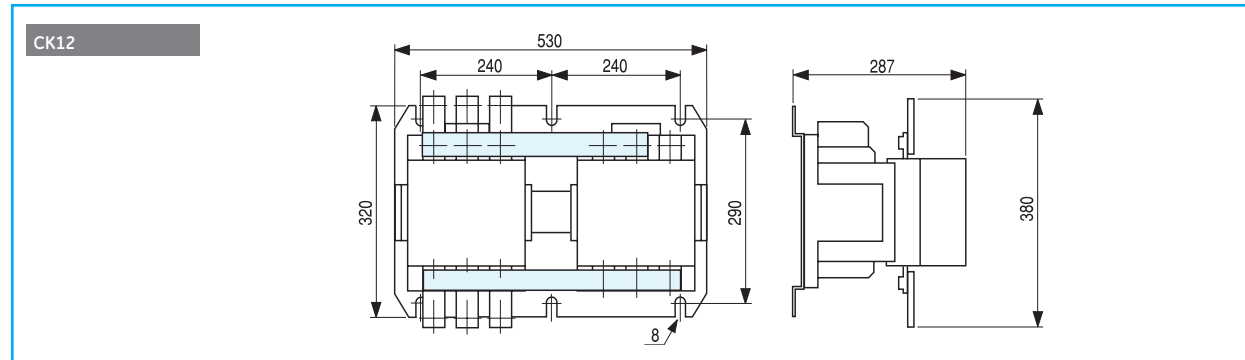
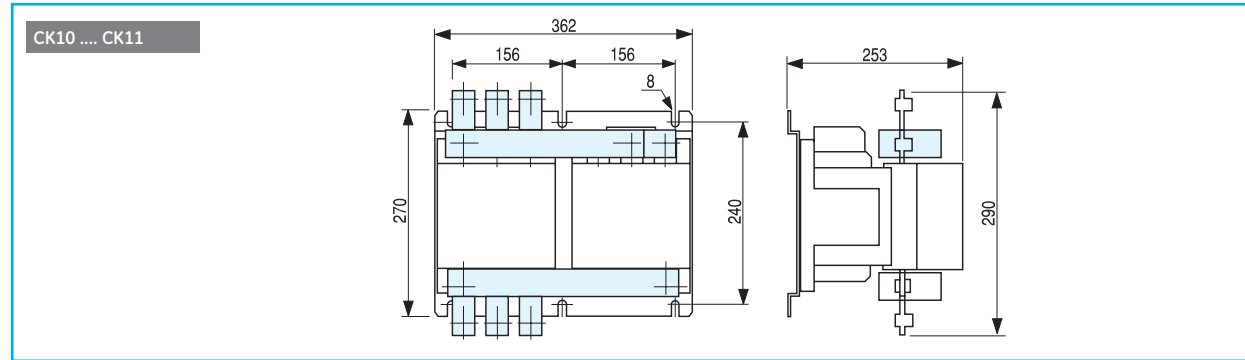

Series CK - Direct-on-line reversing starters with thermal overload relay

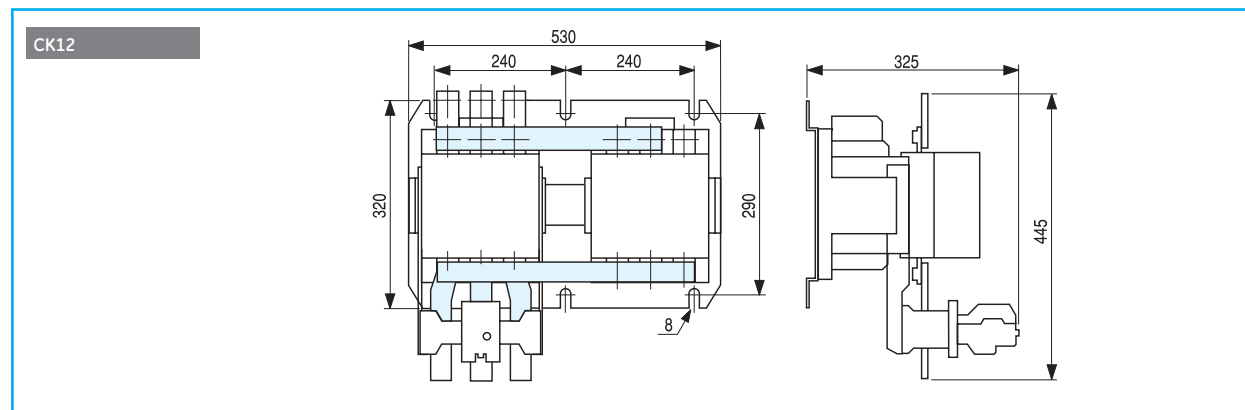
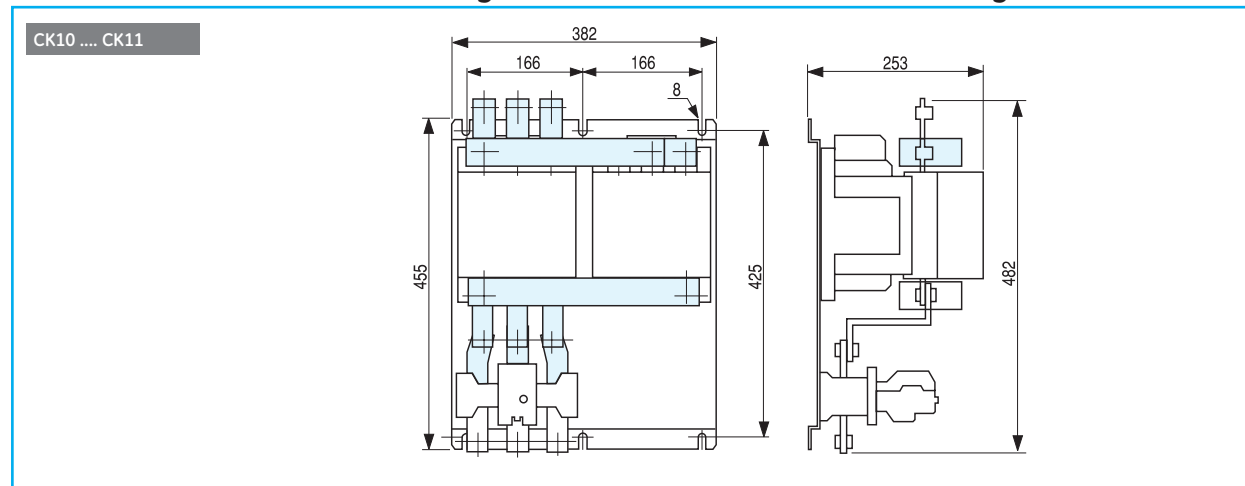

Dimensions

Intro

A

B

C

D

E

F

G

H

I

J/X



Dimensional drawings

Series CL - Star-delta starters

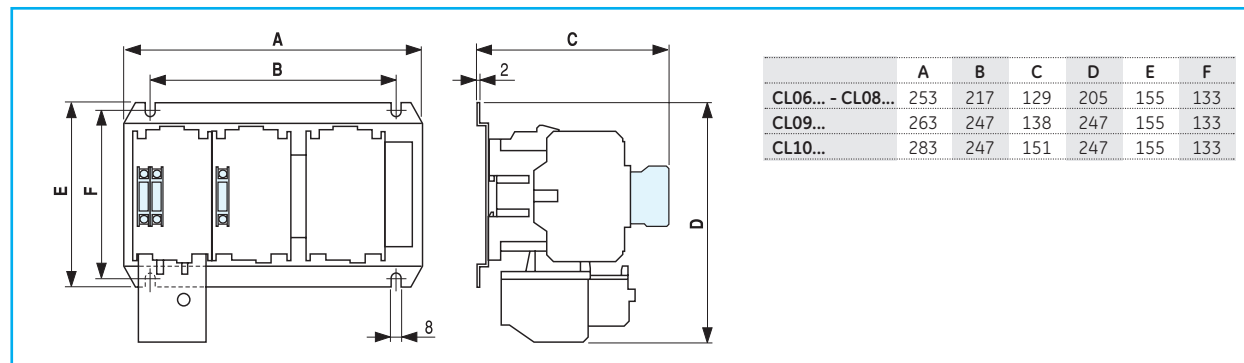
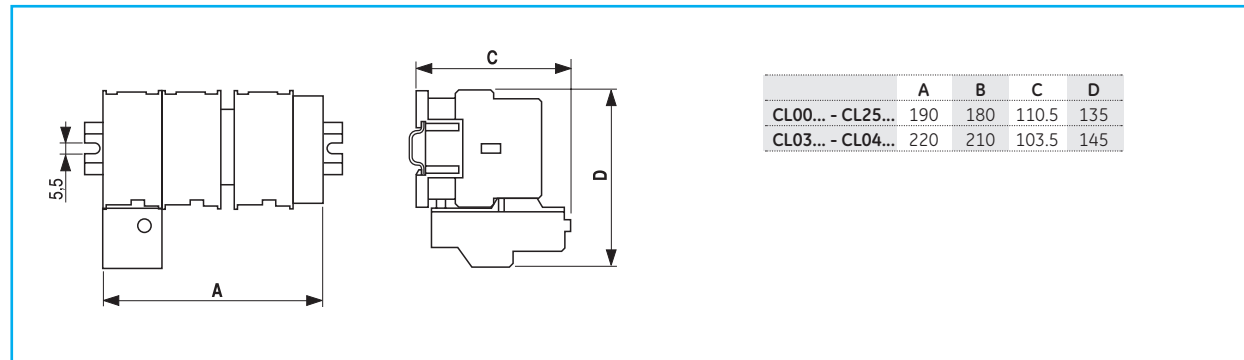

Series CK - Star-delta starters

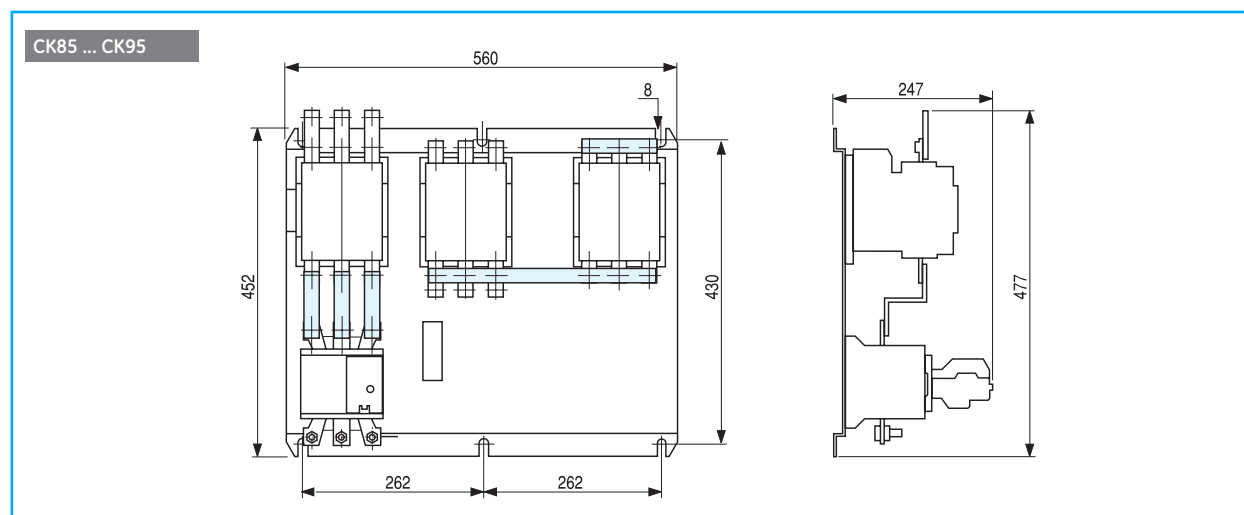
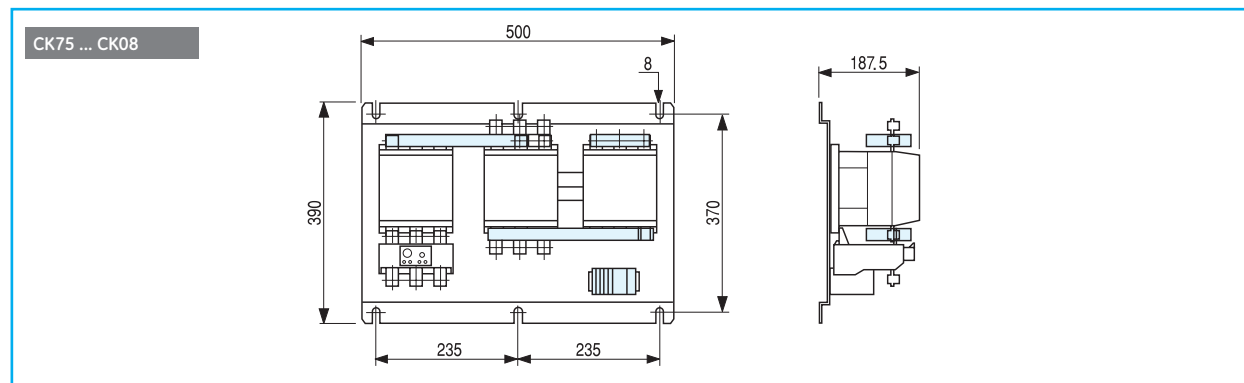

- Motorstarters
- Intro
- A
- B
- C
- D
- E
- F
- G
- H
- I
- J/X



Series CK - Star-delta starters

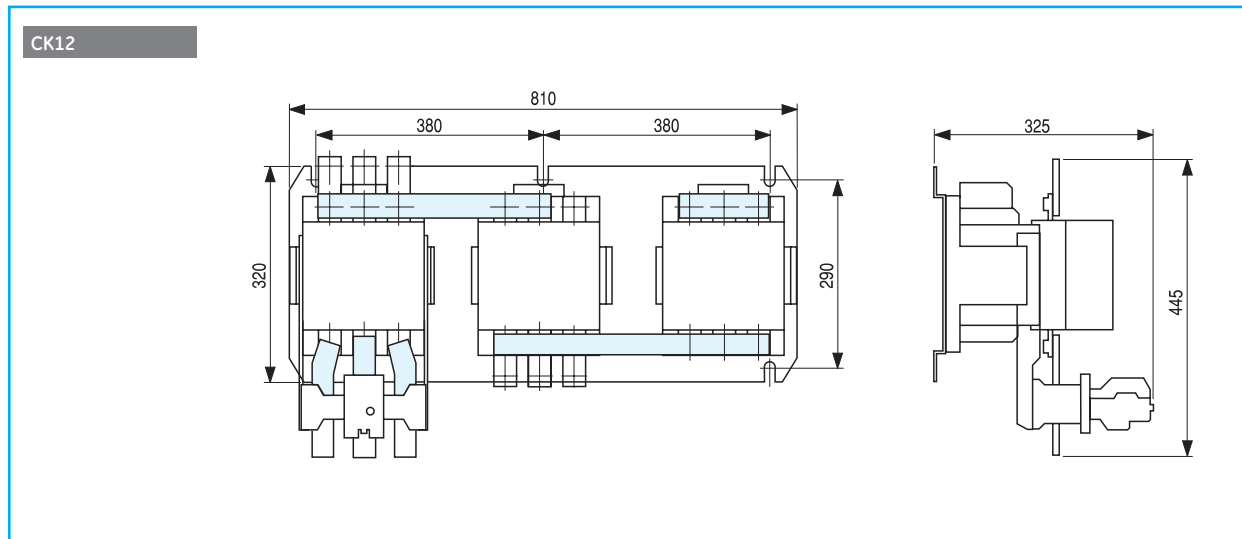
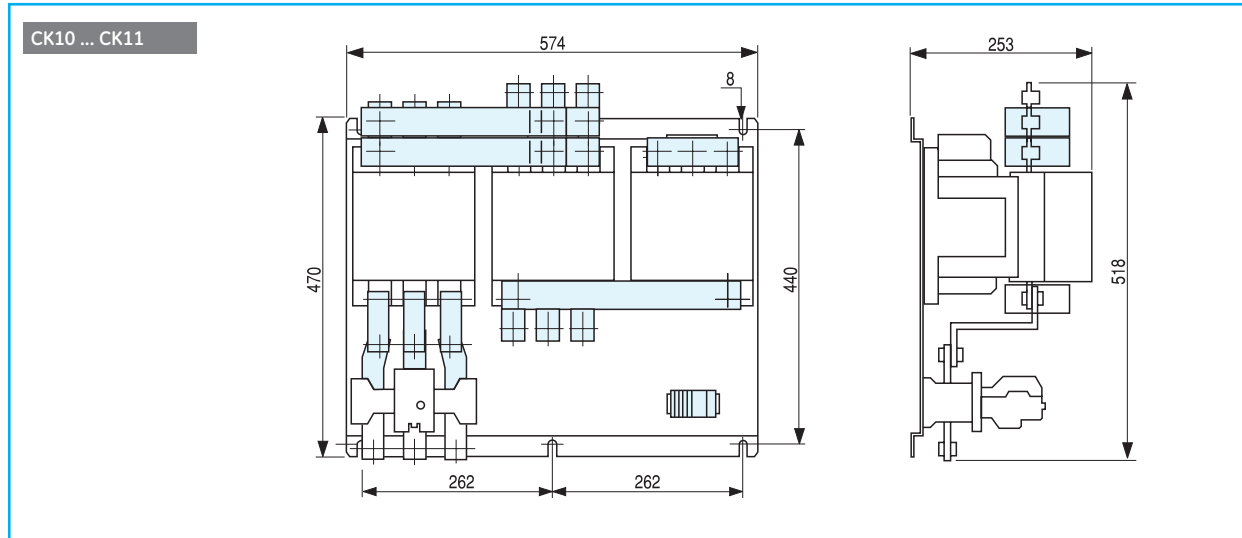

Dimensions

Intro

A

B

C

D

E

F

G

H

I

J/X



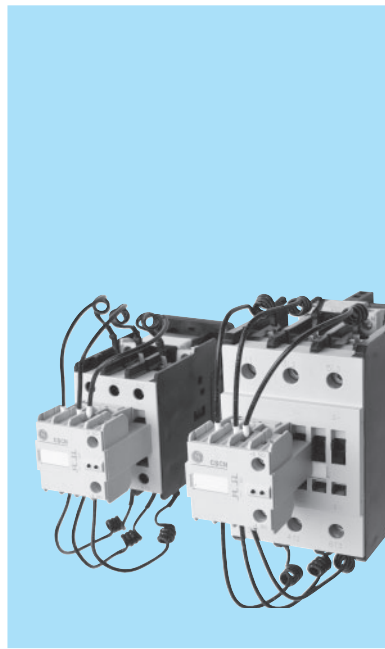

### Contactors for capacitors switching

*With built-in resistance to switch three phase capacitor banks*

"CSCN" contactors incorporate a front block with three early-make auxiliary contacts together with 6 quick discharge resistors (two per phase) through which the capacitors are switched to the network, reducing the current peak. Once the resistors have damped the current peak, the main contacts short-circuit the resistors, carrying the uninterrupted current. A few milliseconds later the early-make auxiliary contact closes to guarantee that all current flows through the main contacts.

#### Standards

- IEC/EN 60947-1    CENELEC HD 419
- IEC/EN 60947-4-1    VDE 0660/102
- IEC/EN 60947-5-1    NFC 63-110
- EN 50005    ASE 1025
- UL 508    UNE 20109
- CSA C22.2/14

#### Approvals/Marking



#### Standard voltages

To complete the catalogue number, replace the symbol ♦ by the code corresponding to the voltage and frequency of the control circuit, other voltages on request.

##### Alternating current (V). Dual-frequency

♦	1	2	3	4	5	6	7	8	9
50/60Hz	24	42	110	120	220	230	240	440	48
			115						

##### Alternating current (V)

♦	E	K	L	N	T	U	W	Y	Z
50Hz	32	127		220		380	415	500	660
				230		400			690
60Hz			208	277	380	480	460	600	

- Order codes ● pg. A.145
- Technical data ● pg. A.146
- Dimensional drawings ● pg. A.148



Contactor for capacitors switching

Ith	Ambient temperature										Fuse gl - gG	Contacts		Cat. no. <sup>(1)</sup>	Pack
	$\theta \leq 55^\circ\text{C}$					$\theta \leq 70^\circ\text{C}$						.3   .4	.1  .2		
	230V 240V kvar	400V kvar	415V kvar	500V kvar	660V 690V kvar	230V 240V kvar	400V kvar	415V kvar	500V kvar	660V 690V kvar					
25	7.5	12.5	13	16	15	3.7	7.5	8	9.5	10	25	2 0 1 1 0 2	CSCN12A320 ♦ CSCN12A311 ♦ CSCN12A302 ♦	1 1 1	
32	10	16.7	17	21	20	5	10	11	12.5	12.5	35	2 0 1 1 0 2	CSCN16A320 ♦ CSCN16A311 ♦ CSCN16A302 ♦	1 1 1	
45	12.5	20	21	25	25	7.5	12.5	13	16	15	40	1 0 0 1 2 1 1 2	CSCN20A310 ♦ CSCN20A301 ♦ CSCN20A321 ♦ CSCN20A312 ♦	1 1 1 1	
45	15	25	26	31	30	10	15	16	18	20	50	1 0 0 1 2 1 1 2	CSCN25A310 ♦ CSCN25A301 ♦ CSCN25A321 ♦ CSCN25A312 ♦	1 1 1 1	
60	20	30	31	38	35	16	22	23	27	25	63	1 0 0 1 2 1 1 2	CSCN30A310 ♦ CSCN30A301 ♦ CSCN30A321 ♦ CSCN30A312 ♦	1 1 1 1	
90	25	45	47	56	55	20	35	36	44	40	80	1 0 0 1 2 0 1 1 1 2	CSCN45A310 ♦ CSCN45A301 ♦ CSCN45A320 ♦ CSCN45A311 ♦ CSCN45A312 ♦	1 1 1 1 1	
110	35	55	57	69	65	30	45	47	56	50	125	1 0 0 1 2 0 1 1 1 2	CSCN55A310 ♦ CSCN55A301 ♦ CSCN55A320 ♦ CSCN55A311 ♦ CSCN55A312 ♦	1 1 1 1 1	
140	45	70	73	88	85	35	60	62	75	70	160	1 0 0 1 2 0 1 1 1 2	CSCN70A310 ♦ CSCN70A301 ♦ CSCN70A320 ♦ CSCN70A311 ♦ CSCN70A312 ♦	1 1 1 1 1	
Spare coils															
For series CSCN12 ... CSCN25													LB1A ♦	5	
For series CSCN30													LB3A ♦	5	
For series CSCN45 ... CSCN70													LB4A ♦	5	

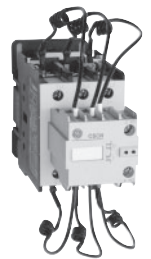

(1) To complete the reference, replace ♦ by the code corresponding to the voltage and frequency of the control circuit. (see pg. A.144)

Oder codes

Intro

A

B

C

D

E

F

G

H

I

J/X



Technical data

Technical characteristics

		CSCN12	CSCN16	CSCN20	CSCN25	CSCN30	CSCN45	CSCN55	CSCN70
<b>Main circuit (poles)</b>									
Rated operational voltage	(V)	690	690	690	690	690	690	690	690
Rated insulation voltage according to IEC947	(V)	1000	1000	1000	1000	1000	1000	1000	1000
Rated thermal current	(A)	25	32	45	45	60	90	110	140
Max. power utilization at 55°C	230/240V (kvar)	7,5	10	12,5	15	20	25	35	45
	380/400V (kvar)	12,5	16,7	20	25	30	45	55	70
	660/690V (kvar)	15	20	25	30	35	55	65	85
Electrical endurance	(ops.)	280.000	280.000	280.000	250.000	200.000	150.000	120.000	90.000
Max. ops./hour	(ops./hour)	350	350	350	240	240	150	150	150

Control circuit

Standard voltages	50Hz (V)	24-690	24-690	24-690	24-690	24-690	24-690	24-690	24-690
	60Hz (V)	24-600	24-600	24-600	24-600	24-600	24-600	24-600	24-600

Consumption

Single frequency	Mar. circuit open	(VA)	45	45	48	48	88	191	191	198
	Mar. circuit closed	(VA)	6	6	7	7	9	15,5	15,5	17
Dual frequency	Mar. circuit open	(VA)	54	54	58	58	125	245	245	250
	Mar. circuit closed	(VA)	7	7	8	8	11,5	20	20	23
Dual frequency	Mar. circuit open	(VA)	35	35	39	39	110	215	215	220
	Mar. circuit closed	(VA)	5	5	6	6	11	15	15	19

Instantaneous auxiliary contact blocks

Rated insulation voltage Ui	(V)	1000
Rated thermal current Ith	(A)	10

Ambient conditions

Storage temperature	(°C)	-50 ... +80
Operating temperature	(°C)	-25 to +55 (without derating)
Altitude up to 3000m		Nominal values
Mounting positions		Vertical mounting +/- 30°

Terminal capacity and tightening torque

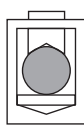
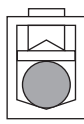
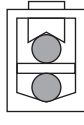
		CSCN12	CSCN16	CSCN20	CSCN25	CSCN30	CSCN45	CSCN55	CSCN70
	Solid, stranded and finely stranded without end sleeve (mm²)	1 x 0.5 ... 2,5		1 x 0.5 ... 2,5		-	-	-	-
	Finely stranded with or without end sleeve (mm²)	1 x 2.5 ... 6		1 x 2.5 ... 10		-	-	-	-
	AWG wires	1 x 1 ... 2,5		1 x 1 ... 2,5		-	-	-	-
		1 x 2.5 ... 6		1 x 2.5 ... 10		-	-	-	-
	Tightening torque (Nm)	1.6		2.2		-	-	-	-
	(Lb x in.)	15		20		-	-	-	-
	Solid, stranded and finely stranded without end sleeve (mm²)	-		-		0.75 ... 16	1 ... 35	1.5 ... 50	
	Finely stranded with end sleeve (mm²)	-		-		0.75 ... 16	1 ... 35	1.5 ... 50	
	Finely stranded without end sleeve (mm²)	-		-		1 ... 16	1 ... 35	1.5 ... 50	
	AWG wires	-		-		18 ... 6	16 ... 2	16 ... 2	
	Tightening torque (Nm)	-		-		1.8	4	5.6	
	(Lb x in.)	-		-		16	35	50	
	Solid (mm²)	-		-		0.75 ... 16	1 ... 16	4 ... 35	
	Stranded (mm²)	-		-		0.75 ... 16	1 ... 25	4 ... 35	
	Finely stranded without end sleeve (mm²)	-		-		0.75 ... 16	1 ... 25	4 ... 35	
	Finely stranded with end sleeve (mm²)	-		-		1 ... 16	1 ... 25	4 ... 35	
	AWG wires	-		-		18 ... 6	16 ... 4	10 ... 1	
Tightening torque (Nm)	-		-		1.8	4	5.6		
	(Lb x in.)	-		-		16	35	50	
	Solid, stranded and finely stranded without end sleeve (mm²)	-		-		Max. 16	Max. 50 ... 4	Max. 50 ... 35	
	Finely stranded without end sleeve (mm²)	-		-		Max. 16	Max. 35 ... 2,5	Max. 35	
		-		-			Max. 25 ... 16		
	Finely stranded with end sleeve (mm²)	-		-		Max. 16	Max. 35 ... 16	Max. 35	
		-		-			Max. 25 ... 25		
AWG wires	-		-		Max. 6	Max. 2 ... 12	Max. 1		
	-		-			Max 4 ... 4			
Tightening torque (Nm)	-		-		1.8	4	5.6		
	(Lb x in.)	-		-		16	35	50	

Intro

A

B

C

D

E

F

G

H

I

J/X





Standard contactors

Series "CL" and "CK" contactors, to switch three phase capacitor banks

Electrical endurance: >100,000 operations

Contactor		$\theta \leq 55^{\circ}\text{C}$					$\theta \leq 70^{\circ}\text{C}$					Fuse gl - gG	I max. (peak)
Type <sup>III</sup>	Ith	220V 230V 240V kvar	400V kvar	415V kvar	500V kvar	690V 660V kvar	220V 230V 240V kvar	400V kvar	415V kvar	500V kvar	690V 660V kvar		
	A											A	A
CL00A	25	3	5	5.5	6.5	5.7	2.4	4	4.5	5.2	4.5	10	1000
CL01A	25	4.5	9.5	10.5	12.5	11	3.6	6	6.5	10	7	16	1000
CL02A	32	6.5	11	12	14.5	12.5	5.2	8.5	9	11.5	10	25	1000
CL25A	45	7.5	12.5	14	16	15	6.5	10	11	13	12	25	1000
CL03A	45	9	15	16.5	20	17.5	7.2	12	13	16	14	35	2500
CL04A	60	12.5	21	23	27.5	24	10	17	18	22	19.5	40	2500
CL45A	60	16.5	25	27	32	30	13	20	22	25	22	50	2500
CL06A	90	22	40	43	52	50	17	30	33	41	35	80	3500
CL07A	110	25	45	48	58	65	19	35	37	46	40	125	3500
CL08A	110	30	50	54	65	70	22	40	43	52	50	125	3500
CL09A	140	40	65	70	85	95	35	58	62	75	85	160	3500
CL10A	140	50	80	85	105	120	43	70	75	90	105	160	3500
CK75C	250	60	110	118	145	150	48	88	94	116	120	250	5000
CK08C	250	70	125	135	162	170	56	100	107	130	136	250	5000
CK85B	315	80	150	160	195	200	64	120	130	156	160	315	5000
CK09B	315	95	165	177	215	230	85	148	160	192	205	315	5000
CK95B	450	105	190	205	250	288	95	175	188	230	265	450	5500
CK10C	600	135	260	280	340	370	120	235	252	375	330	630	10000
CK11C	700	190	325	350	425	450	152	260	280	340	360	800	10000
CK12B	1000	250	400	430	520	600	200	320	344	416	480	1000	12000
CK13B	1250	315	525	565	685	650	252	420	452	548	520	1250	15000

[1] To complete contactor reference, see A.52 for CL and A.62 for CK

Technical data

Intro

A

B

C

D

E

F

G

H

I

J/X



Dimensional drawings

Contactors for capacitors switching

CSCN12..., CSCN16...

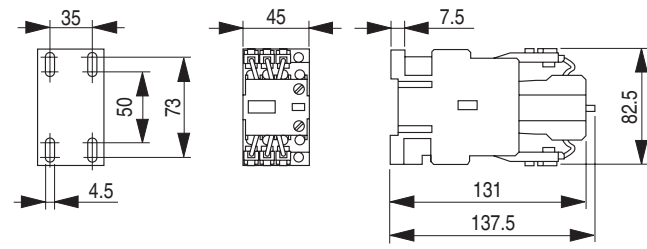

CSCN20..., CSCN25...

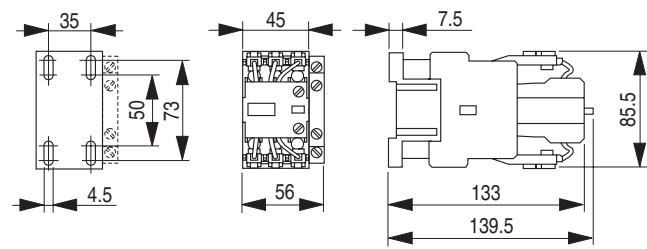

CSCN30...

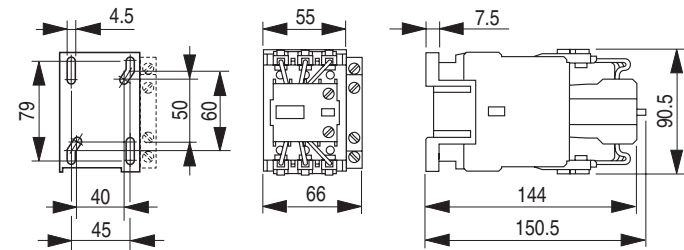

CSCN45..., CSCN55...

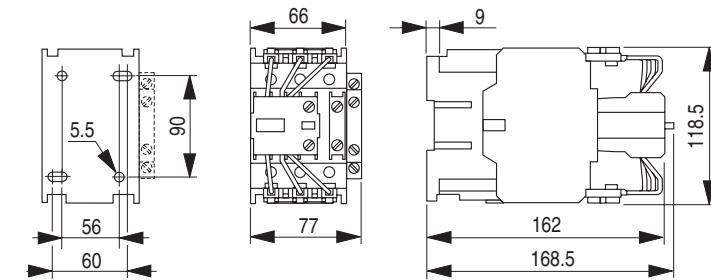

CSCN70...

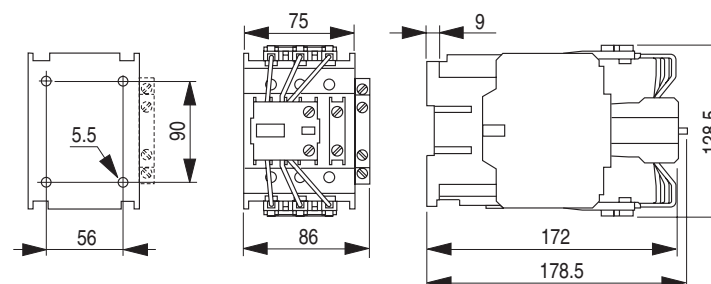



Notes

Grid area for notes

Dimensions

Intro

A

B

C

D

E

F

G

H

I

J/X



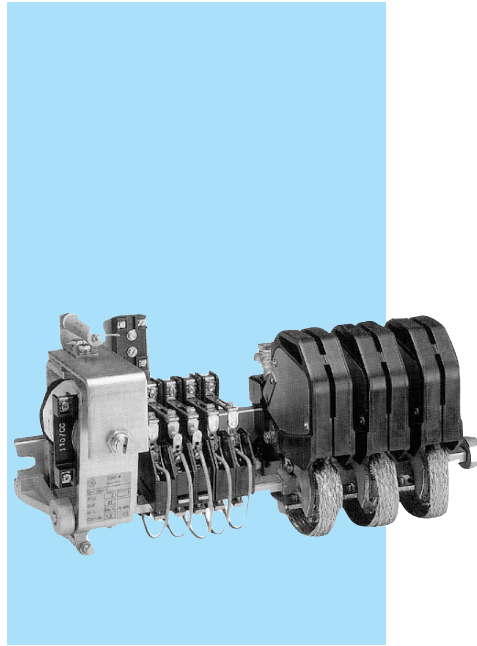

## Clapper contactors 40A to 800A (AC-3) / 45A to 1200A (AC-1)

AC and DC control using a bridge rectifier, designed to meet the most recent stringent requirements in terms of reliability, service life and performance.

### Main characteristics

- Sliding contact holder, set on self-centering and self-lubricating bronze bushings
- Minutubes made of high-strength, high electrical resistance material
- Individual auxiliary contacts

### Construction

Variable composition contactors (the number of main poles and auxiliary contacts may vary), preferably secured on mounts

### Control circuit

Solid iron magnetic circuit with coil powered by direct or rectified current, particularly for heavy-duty applications (e.g., cranes, roll mills, reversing winches, etc.). The coils are sized for intermittent operation. For continuous operation, insert an economy resistor in series with the coil using the respective auxiliary contact.

### Main contacts

The sintered main contacts are classified as Type 4/2 for intermittent operation and Type 5/2 for continuous operation.

The 4/2 sintered contact may be used only for heavy-duty operation when the number of switching operations per hour is above 60 and the operating intermittence is equal or less than 60% (cranes, roll mills, etc.).

If used for continuous operation, the contact will overheat.

The 5/2 sintered contact may be used only for normal duty when the number of switching operations per hour is equal to or less than 60% and the operating intermittence is above 60%.

### Auxiliary contacts

Individual NO or NC single-break contacts

Possibility to advance or delay contact making or breaking

### Special versions

The following items may be supplied upon request:

- Contactors with coils having an operating limit that exceeds the limits required by the standards
- Contactors with an operating voltage up to 3000V (rotary disconnect switches, induction furnaces, etc.)
- Vertical mechanical interlocks ideal for interlocking 3 contactors.

### Control voltage and normal combinations

Normal rated voltages, shaft spacing and combinations (main and auxiliary poles) have been defined for each switchgear unit, thereby allowing the contactor to be rapidly selected.

AC rated voltages: 24V - 48V - 110V - 220/230V

DC rated voltages: 24V - 48V - 110V - 220/230V

Spacing between standardised shafts and combinations:

See pages A.160 to A.162

Standard center-to-center spacing (mm): 150, 200, 250, 300, 350, 400, 450, 500, 600, 700, 800, 900, 1000

### Standard voltages

#### Alternating current (V) Dual-frequency coils

	AP	CP	EP	GP
50/60Hz	24	48	110	220

#### Direct current (V)

	A	B	C	D	E	F	G	H	M	R
Voltage	20	24	40	48	97	110	197	220	230	125

### Spare parts and additional components

Spare parts and additional components for the contactors are listed on page A.155.

Order codes ● pg. A.151

Coils ● pg. A.154

Spare parts ● pg. A.155

Technical data ● pg. A.158

Dimensional drawings ● pg. A.160



**Main poles**

The poles can be constructed as follows, depending on the operating conditions:

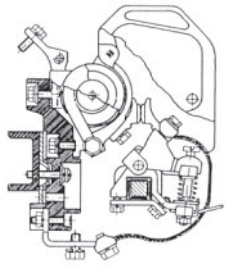

**Z design (NO)**

- For load breaking, with high breaking capacity
- For AC or DC use
- Equipped with magnetic arc-quenching coil. In the case of AC, the poles are normally supplied with an appropriate arc-quenching coil for the maximum rated current of the pole.
- Arc-quenching coils for medium rated currents with respect to the expected peak current are available for DC use upon request, for more effective pole performance (see table on page A.154).

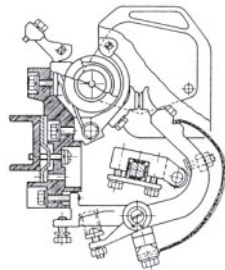

**RN design (NC)**

- Based on the use of break poles, which are open when the coil is energized and closed when the coil is de-energized.
- For AC or DC use in special circuits where high interrupting capacities are not required.
- This design is intended to be used with contactors R1, R2, R3, R4, R5, R7.

Poles	R1	R2	R3	R4	R5	R6	R7	R8	R9
Z	■	■	■	■	■	■	■	■	■
RN	■	■	■	■	■		■		

**Order codes - Clapper contactors**

Peak operating current		AC-3 admissible rated powers				Electric endurance	AC or DC	Pack.
Resistive loads	Motors <440V, 3 ~ 50/60Hz	220V 230V	380V 400V	415V 440V	500V			
AC1 A	AC3 A	kW HP	kW HP	kW HP	kW HP	Cat. AC3 Switching operations	See the following pages A.152 and A.153 on how to complete the catalogue number	
45	40	11,5	20	20	20	1 × 10 <sup>6</sup>	R1 ...	1
90	90	26	45	45	45	1 × 10 <sup>6</sup>	R2 ...	1
125	120	36.5	62	62	73.5	1 × 10 <sup>6</sup>	R3 ...	1
250	200	72.5	100	100	120	1 × 10 <sup>6</sup>	R4 ...	1
320	320	93	160	160	165	1.2 × 10 <sup>6</sup>	R5 ...	1
450	450	130	225	225	300	1.5 × 10 <sup>6</sup>	R6 ...	1
630	630	184	315	315	400	1 × 10 <sup>6</sup>	R7 ...	1
800	800	232	400	400	500	0.9 × 10 <sup>6</sup>	R8 ...	1
1500	-	-	-	-	-	-	R9 ...	1

Order codes

Intro

A

B

C

D

E

F

G

H

I

J/X



Catalogue number structure

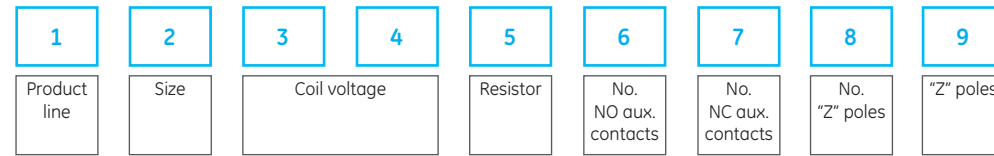

**1**

Size		<b>1</b>	<b>2</b>
	Ith		
Max.	45	R	1
500V AC	90	R	2
250V DC	125	R	3
	250	R	4
	320	R	5
	450	R	6
	630	R	7
	800	R	8
	1200	R	9

**6**

Auxiliary contacts		<b>6</b>	<b>7</b>
NO	NC		
1		1	
2		2	
3		3	
4		4	
5		5	
6		6	
	1		1
	2		2
	3		3
	4		4

**11**

"RN" poles" (NC)		<b>11</b>
"RN" poles	"RN" poles	
0	0	-
1	1	1
2	2	2
3	3	3
4	4	4

Note: The "RN" poles are not available for the R6, R8 and R9 types.

**3**

Coil voltage		<b>3</b>	<b>4</b>
AC	DC		
<b>Types R1 ... R7</b>			
24V		A	P
48V		C	P
110V		E	P
220V		G	P
	20V	A	-
	24V	B	-
	40V	C	-
	48V	D	-
	97V	E	-
	110V	F	-
	197V	G	-
	220V	H	-
	230V	M	-
	125V	R	-
<b>Types R8 and R9</b>			
	110V	E	P
	220V	G	P
	110V	E	-
	197V	F	-
	220V	G	-
	230V	H	-
	125V	M	-

**8**

"Z" poles" (N)		<b>8</b>
"Z" poles		
0		-
1		1
2		2
3		3
4		4

**9**

"Z" poles		<b>9</b>
Type of pole		
Z	Z	
No "Z" poles	-	

**12**

"RN" poles		<b>12</b>
Type of pole		
RN	V	
No "RN" poles	-	

Note: The "RN" poles are not available for the R6, R8 and R9 types.

**13**

Arc-quenching coil «RN» poles	Standard Upon request		
	A	B	C
Type			
R1	45A	14A	25A
R2	90A	45A	-
R3	125A	75A	-
R4	200A	50A	130A
R5	320A	150A	-
R6	-	-	-
R7	630A	320A	-
R8	-	-	-
R9	-	-	-

Note: The "RN" poles are not available for the R6, R8 and R9 types.

**5**

Economy resistor		<b>5</b>
	If required (5/2 contacts)	R
	If not required	-

**10**

Arc-quenching coil "Z" poles	Standard Upon request		
	A	B	C
Type			
R1	45A	14A	25A
R2	90A	45A	-
R3	125A	75A	-
R4	200A	50A	130A
R5	320A	150A	-
R6	450A	270A	-
R7	630A	320A	-
R8	800A	320A	400A
R9	1200A	-	-

**14**

Type of contacts		<b>14</b>
Type		
4/2	Intermittent op.	4
5/2	Continuous op.	5





<b>10</b>	<b>11</b>	<b>12</b>	<b>13</b>	<b>14</b>	<b>15</b>	<b>16</b>	<b>17</b>	<b>18</b>
Arc-quenching coil "Z" poles	No. "RN" poles	"RN" poles	Arc-quenching coil "RN" poles	Type of contacts	Stationary support	Space	Shaft	Isolation

Stationary support	Contactor type			
	R1 R2 R3	R4 R5	R6 R7 R8	R9
<b>15</b>	Length (mm)			
	150	A	-	-
	200	B	-	-
	250	C	C	-
	300	D	D	-
	350	E	E	E
	400	F	F	F
	450	G	G	G
	500	H	H	H
	600	I	I	I
	700	L	L	L
	800	M	M	M
	900	N	N	N
	1000	O	O	O

Shaft (≤stat. sup.)	Contactor type			
	R1 R2 R3	R4 R5	R6 R7 R8	R9
<b>17</b>	Length (mm)			
	150	A	-	-
	200	B	-	-
	250	C	C	-
	300	D	D	-
	350	E	E	E
	400	F	F	F
	450	G	G	G
	500	H	H	H
	600	I	I	I
	700	L	L	L
	800	M	M	M
	900	N	N	N
	1000	O	O	O

Isolation	<b>18</b>
For more isolation	M
Not required	-

Space	<b>16</b>
No space	Station. sup.=Shaft -
Space	Left S
	Right -

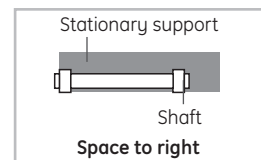
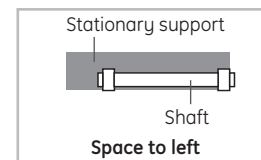
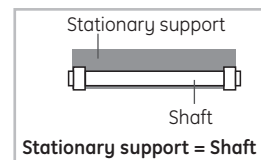

Order codes

Intro

A

B

C

D

E

F

G

H

I

J/X







Spare parts

Contactors	Description	Cat. no.	Ref. no.	Pack (units)	
R1	"Z" stationary part with 14A arc-quenching coil and spark suppressor	390/3921PFZCS14	202273	1	
	"Z" stationary part with 25A arc-quenching coil and spark suppressor	390/3921PFZCS25	244172	1	
	"Z" stationary part with 45A arc-quenching coil and spark suppressor	390/3921PFZCS45	202274	1	
	"RN" stationary part with spark suppressor	390/3921PFRN	244173	1	
	"Z" moving part (with pressure spring and strap)	390/3921PMZI	202276	1	
	"RN" moving part (with pressure spring and strap)	390/3921PMRN	202275	1	
	Stationary and moving main contact, type 4/2 (intermittent operation)	390/3921/2FOM4/2	214120	1	
	Stationary and moving main contact, type 5/2 (continuous operation)	390/3922FOM5/2	214121	1	
	Spark suppressor for "Z" and "RN" poles	390/3921PZ	202277	1	
	R2	"Z" stationary part with 45A arc-quenching coil and spark suppressor	390/3922PFZCS45	244744	1
"Z" stationary part with 90A arc-quenching coil and spark suppressor		390/3922PFZCS90	202278	1	
"RN" stationary part with spark suppressor		390/3922PFRN	212709	1	
"Z" moving part (with pressure spring and strap)		390/3922PMZI	202279	1	
"RN" moving part (with pressure spring and strap)		390/3922PMRN	213014	1	
Stationary and moving main contact, type 4/2 (intermittent operation)		390/3921/2FOM4/2	214120	1	
Stationary and moving main contact, type 5/2 (continuous operation)		390/3922FOM5/2	214121	1	
Spark suppressor for "Z" and "RN" poles		390/3922PZ	202280	1	
R3		"Z" stationary part with 75A arc-quenching coil and spark suppressor	390/3923PFZCS75	244745	1
		"Z" stationary part with 125A arc-quenching coil and spark suppressor	390/3923PFZCS125	202281	1
	"RN" stationary part with spark suppressor	390/3923PFRN	213986	1	
	"Z" moving part (with pressure spring and strap)	390/3923PMZI	202283	1	
	"RN" moving part (with pressure spring and strap)	390/3923PMRN	202282	1	
	Stationary and moving main contact, type 4/2 (intermittent operation)	390/3923/2FOM4/2	214122	1	
	Stationary and moving main contact, type 5/2 (continuous operation)	390/3923FOM5/2	214123	1	
	Spark suppressor for "Z" and "RN" poles	390/3923PZ	202284	1	
	R4	"Z" stationary part with 125A arc-quenching coil and spark suppressor	390/3924PFZCS125	202288	1
		"Z" stationary part with 200A arc-quenching coil and spark suppressor	390/3924PFZCS200	202289	1
"RN" stationary part with spark suppressor		390/3924PFRN	202287	1	
"Z" moving part (with pressure spring and strap)		390/3924PMZI	202291	1	
"RN" moving part (with pressure spring and strap)		390/3924PMRN	202290	1	
Stationary main contact, type 4/2 (intermittent operation)		390/3924F4	214124	1	
Moving main contact, type 4/2 (intermittent operation)		390/3924M4/2	214126	1	
Stationary main contact, 5/2 type (continuous operation)		390/3924F5/2	204178	1	
Moving main contact, type 5/2 (continuous operation)		390/3924M5/2	214127	1	
Spark suppressor for "Z" and "RN" poles		390/3924PZ	202292	1	
R5	"Z" stationary part with 125A arc-quenching coil and spark suppressor	390/3925PFZCS150	213573	1	
	"Z" stationary part with 320A arc-quenching coil and spark suppressor	390/3925PFZCS320	202295	1	
	"RN" stationary part with spark suppressor	390/3925PFRN	244746	1	
	"Z" moving part (with pressure spring and strap)	390/3925PMZI	202298	1	
	"RN" moving part (with pressure spring and strap)	390/3925PMRN	202297	1	
	Stationary main contact, type 4/2 (intermittent operation)	390/3925F4/2	214128	1	
	Moving main contact, type 4/2 (intermittent operation)	390/3925M4/2	214130	1	
	Stationary main contact, 5/2 type (continuous operation)	390/3925F5/2	214129	1	
	Moving main contact, type 5/2 (continuous operation)	390/3925M5/2	214131	1	
	Spark suppressor for "Z" and "RN" poles	390/3925PZ	202299	1	
R5	"Z" stationary part with 270A arc-quenching coil and spark suppressor	390/3926PFZCS270	202303	1	
	"Z" stationary part with 450A arc-quenching coil and spark suppressor	390/3926PFZCS450	213574	1	
	"Z" moving part (with pressure spring and strap)	390/3926PMZI	202304	1	
	Stationary main contact, type 4/2 (intermittent operation)	390/3926F4/2	214133	1	
	Moving main contact, type 4/2 (intermittent operation)	390/3926M4/2	214135	1	
	Stationary main contact, 5/2 type (continuous operation)	390/3926F5/2	214134	1	
	Moving main contact, type 5/2 (continuous operation)	390/3926M5/2	214136	1	
Spark suppressor for "Z" and "RN" poles	390/3926PZ	202654	1		

Order codes

Intro

A

B

C

D

E

F

G

H

I

J/X



**Spare parts (continued)**

Contactor	Description	Cat. no.	Ref. no.	Pack (units)
R7	"Z" stationary part with 320A arc-quenching coil and spark suppressor	390/3927PFZCS320	202307	1
	"Z" stationary part with 630A arc-quenching coil and spark suppressor	390/3927PFZCS630	202308	1
	"RN" stationary part with spark suppressor	390/3927PFRN	202306	1
	"Z" moving part (with pressure spring and strap)	390/392PMZI	202310	1
	"RN" moving part (with pressure spring and strap)	390/3927PMRN	202309	1
	Stationary main contact, type 4/2 (intermittent operation)	390/3927F4/2	214137	1
	Moving main contact, type 4/2 (intermittent operation)	390/3927M4/2	214139	1
	Stationary main contact, 5/2 type (continuous operation)	390/3927F5/2	214138	1
	Moving main contact, type 5/2 (continuous operation)	390/3927M5/2	214140	1
	Spark suppressor for "Z" and "RN" poles	390/3927PZ	202311	1
	R8	"Z" stationary part with 400A arc-quenching coil and spark suppressor	3908PFZCS400	202555
"Z" stationary part with 800A arc-quenching coil and spark suppressor		3908PFZCS800	202562	1
"Z" moving part (with pressure spring and strap)		3908PMZ	202563	1
Stationary main contact, type 4/2 (intermittent operation)		3908F4/2	214144	1
Moving main contact, type 4/2 (intermittent operation)		3908/9M4/2	214141	1
Stationary main contact, 5/2 type (continuous operation)		3908F5/2	214145	1
Moving main contact, type 5/2 (continuous operation)		3908/9M5/2	214142	1
Spark suppressor for "Z" and "RN" poles		3908PZ	202564	1
R9	"Z" stationary part with 1200A arc-quenching coil and spark suppr.	3909PFZCS120	244983	1
	"Z" moving part (with pressure spring and strap)	3909PMZ	212962	1
	Stationary main contact, type 4/2 (intermittent operation)	3909F4/2	204179	1
	Moving main contact, type 4/2 (intermittent operation)	3908/9M4/2	214141	1
	Stationary main contact, 5/2 type (continuous operation)	3909F5/2	204180	1
	Moving main contact, type 5/2 (continuous operation)	3908/9M5/2	214142	1



Operating categories

			R1...	R2...	R3...	R4...	R5...	R6...	R7...	R8...	R9...		
<b>AC-1</b>	Peak operating current	40°C (A)	45	90	125	250	320	450	630	800	1200		
	at ambient temp. of:	55°C (A)	45	90	125	250	320	450	600	750	1200		
	(for all rated voltages)	70°C (A)	30	70	100	200	280	360	500	700	950		
	Max. operating power Resistor III	230/220V	(kW)	17	30	45	90	114	170	195	240	450	
		400/380V	(kW)	29	55	75	155	196	310	330	410	750	
		440/415V	(kW)	32	57	85	180	227	340	330	500	900	
		500V	(kW)	39	69	102	200	250	390	420	550	1030	
	Conductor	(mm <sup>2</sup> )	10	35	50	120	185	2 x (30x5)	2 x (40x5)	2 x (60x5)	4 x (50x5)		
Operation in % of peak operating current	120 ops./h	(%)	100	100	100	100	100	100	100	100	50		
	300 ops./h	(%)	50	50	50	50	30	30	20	10	10		
<b>AC-3</b>	Peak operating current	Ue = 400V (A)	40	90	110	200	320	450	630	800	-		
	Max. operating power	230/220V	(kW)	11.5	26	36.5	72.5	93	130	184	232	-	
		400/380V	(kW)	20	45	62	100	160	225	315	400	-	
		440/415V	(kW)	20	45	68	100	160	225	315	400	-	
		500V	(kW)	20	45	72.5	120	165	280	400	500	-	
	Use in % of peak operating current	120 ops./h	(%)	100	100	100	100	100	100	100	100	-	
300 ops./h		(%)	50	50	50	50	50	50	30	30	-		
<b>AC-4</b>	Peak operating current	Ue = 500V (A)	18.5	44	55	110	125	150	165	250	-		
	Operating power (200,000 switching)	230/220V	(kW)	4	11	15	33	37	45	50	80	-	
		400/380V	(kW)	9	22	28	55	63	80	90	132	-	
			(HP)	5.3	14.6	19.9	43.9	49.2	59.8	66.5	106	-	
		500V	(kW)	11	25	33	75	90	100	110	225	-	
			(HP)	14.6	33.2	43.9	99.7	119.7	133	146	299	-	
	Peak operating current	≤ 400V (A)	40	90	110	185	280	420	590	700	-		
	Max. operating power	400/380V (kW)	18.5	38	55	90	150	220	300	375	-		
			<b>Ue</b>	<b>Series poles</b>	<b>R1...</b>	<b>R2...</b>	<b>R3...</b>	<b>R4...</b>	<b>R5...</b>	<b>R6...</b>	<b>R7...</b>	<b>R8...</b>	<b>R9...</b>
<b>DC1</b> L/R ≤ 1ms	125V	1	40	85	115	180	300	400	600	700	900		
		2	60	90	125	200	320	450	630	750	1000		
		3	60	90	125	200	320	450	630	800	1250		
		4	60	90	125	200	320	450	630	800	1250		
	220V	1	20	75	110	160	275	350	500	600	800		
		2	30	90	115	200	300	370	560	650	900		
		3	40	90	125	250	320	400	630	750	1000		
		4	40	90	125	250	320	450	630	800	1250		
	440V	1	-	-	-	-	-	-	-	-	-		
		2	-	75	100	200	275	350	500	600	800		
		3	20	90	125	250	320	400	600	700	900		
		4	20	90	125	250	320	450	630	800	1000		
<b>DC3</b> L/R ≤ 2.5ms	125V	1	30	75	100	170	280	380	550	650	-		
		2	40	80	110	200	320	450	630	800	-		
		3	45	90	110	200	320	450	630	800	-		
		4	45	100	120	220	340	480	-	-	-		
	220V	1	-	-	-	-	-	-	-	-	-		
		2	15	65	90	155	245	340	460	550	-		
		3	20	90	110	200	320	450	630	800	-		
		4	25	90	110	200	320	450	630	800	-		
	440V	1	-	-	-	-	-	-	-	-	-		
		2	-	-	-	-	-	-	-	-	-		
		3	10	55	75	120	200	300	400	500	-		
		4	13	70	100	160	260	400	550	660	-		
<b>DC5</b> L/R ≤ 15ms	125V	1	27	50	70	90	240	320	400	500	-		
		2	35	70	90	150	280	380	450	550	-		
		3	40	90	100	200	320	420	500	600	-		
		4	40	90	110	200	320	450	500	650	-		
	220V	1	-	-	-	-	-	-	-	-	-		
		2	13	55	80	140	220	300	410	490	-		
		3	18	80	100	180	290	400	560	700	-		
		4	22	80	100	180	290	400	560	700	-		
	440V	1	-	-	-	-	-	-	-	-	-		
		2	-	-	-	-	-	-	-	-	-		
		3	9	50	67	100	180	270	360	450	-		
		4	11	60	90	130	224	360	480	600	-		

Technical data

Intro

A

B

C

D

E

F

G

H

I

J/X



**Technical data**

**Standards**

IEC/EN 60947-1  
IEC/EN 60947-4-1  
IEC/EN 60947-5-1

**Ambient conditions**

Storage temperature	-55°C to +80°C	
Operating temperature	-40°C to +60°C	
Altitude	up to 2500m	Rated values
	3000 to 4000m	90%le 80%Ue
	4000 to 5000m	80%le 75%Ue

**Climatic withstand capacity (IEC 68-2)**

Continuous testing 40/125/56			
Cold (72h)	Temperature	-40°C	
Dry heat (96h)	Temperature	+125°C	
	Relative humidity	< 50%	
Moist heat (56 days)	Temperature	+40°C	
	Relative humidity	95%	
Cyclic testing			
First half-cycle (12h)	Low temperature	+25°C	
	Relative humidity	93%	
Second half-cycle (12h)	Low temperature	+55°C	
	Relative humidity	95%	
No. consecutive cycles	6		

**Mounting positions**

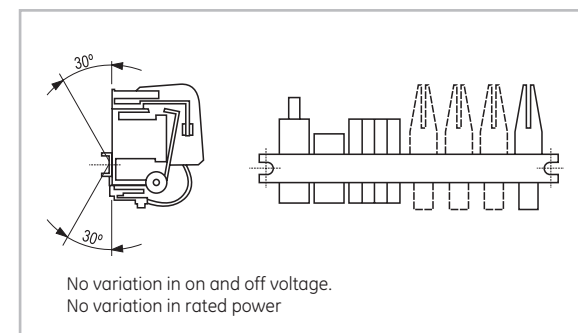

**Maintenance**

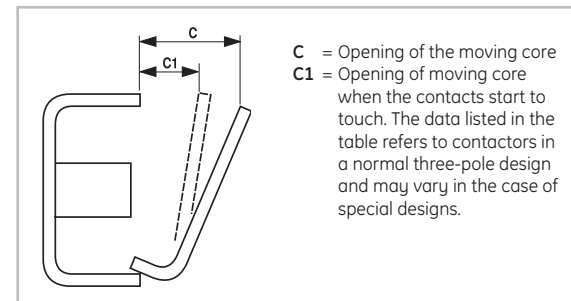

DC power supply		Pressure of closed contact in kg (+10% / -30%)
C (mm) ±1	C1 (mm) ±1	
18	5	0.750
18	5	0.750
20	6	0.750
22	6	1.300
24	7	2.000
28	8	3.500
28	8	5.500
34	10	8.000
34	10	15.000

**Replacement of main contact**

The replacement (due to wear) of the main contacts requires an adjustment to ensure proper distance between the moving and the stationary contacts. The respective adjustment screws should be turned until the main contacts start to touch simultaneously when the gap indicated by A1 or C1 exists between the stationary and the moving magnetic circuit. Make sure that all contactor poles have the same stroke by manually closing the magnetic circuit; if the poles are properly adjusted, they should come into contact at the same time.

If contact wear is abnormal, please contact the manufacturer since the apparatus has been improperly chosen for the application conditions. To replace the contacts, loosen the screw securing the contacts to the respective contact holder, making sure that the screws are well-tightened when installing the new contacts.

GE Power Controls warrants proper operation of the contactors only if the contacts are replaced with OEM contacts.

**Capacity of terminals and torque**

		R1... R2...	R3...	R4...	R5...	R6...	R7...	R8...	R9...
	Single-core conductor (mm²)	2.5...25	2.5...50						
	Multi-strand conductor with terminal sheath (mm²)	2.5...25	2.5...50						
	Multi-strand conductor without terminal sheath (mm²)	2.5...25	2.5...50						
	Multi-strand (mm²)	4...25	4...50						
	Single- and multi-strand AWG (mm²)	16...4	16...2						
	Torque (Nm)	4	5,6						
	(Lb x in)	35	50						
	Multi-strand with terminal (mm²)			1 x 120 2 x 95	1 x 185 2 x 150	-	-	-	
	Clappers			-	-	2 x (30x5)	2 x (40x5)	2 x (60x5)	
	Torque (Nm)			7	23	31	31	31	
	(Lb x in)			60	200	275	275	275	



**Power circuit**

		R1...	R2...	R3...	R4...	R5...	R6...	R7...	R8...	R9...	
Thermal rated current I <sub>th</sub> at θ ≤ 55°C	(A)	45	90	125	250	320	450	630	800	1500	
Rated operating current I <sub>e</sub> AC-3	(A)	40	90	110	200	320	450	630	800	-	
Rated operating voltage U <sub>e</sub> (1)	(V)	500	500	500	500	500	500	500	500	500	
<b>3-pole contactors</b>											
Rated isolation voltage U <sub>i</sub>	(V)	1000	1000	1000	1000	1000	1000	1000	1000	1000	
Maximum continuous current AC-1	(A)	45	90	125	250	320	450	630	800	1200	
Frequency limits (Hz)	(Hz)										
Making capacity (RMS) (IEC947)	(A)	540	1200	1250	2400	3800	5400	7500	9600	4000	
Breaking capacity (RMS) (IEC 947) U <sub>e</sub> ≤ 400V	(A)	450	960	1250	1900	3050	4350	6000	7700	4000	
	U <sub>e</sub> = 500V	(A)	-	650	1050	1900	3050	4350	6000	7700	4000
Short-time current	1 s.	(A)	1200	1500	2000	2500	3000	4250	5000	6000	10000
	5 s.	(A)	800	900	1500	2200	2800	4000	4800	5700	9000
	10 s.	(A)	500	650	1200	1600	2500	3900	4600	5500	8800
	30 s.	(A)	250	300	750	1100	2000	3700	4400	5200	8500
	1 min.	(A)	180	200	450	800	1500	2500	3000	4000	5000
	3 min.	(A)	100	150	250	500	600	900	1500	2300	3000
Recovery time	(min.)	10	10	10	10	10	10	10	10	10	
Fused short-circuit protection	αM	(A)	50	125	160	250	400	630	800	1000	-
	gL-gG	(A)	80	160	200	315	425	630	800	1000	-
Impedance per pole	(mΩ)	1	1	0.5	0.4	0.2	0.3	0.2	0.25	0.10	
Power dissipated per pole	AC-1	(W)	2.1	8.1	7.8	25	20	60	79	160	144
	AC-3	(W)	1.6	8.1	6	16	20	60	79	160	-
Isolation resistance											
Pole-to-pole	(mΩ)	>10	>10	>10	>10	>10	>10	>10	>10	>10	
Pole-to-ground	(mΩ)	>10	>10	>10	>10	>10	>10	>10	>10	>10	
Input-to-output	(mΩ)	>10	>10	>10	>10	>10	>10	>10	>10	>10	

(1) For rated voltages above 500V, contact the manufacturer.

**Control circuit**

		R1...	R2...	R3...	R4...	R5...	R6...	R7...	R8...	R9...
Rated isolation voltage U <sub>i</sub>	(V)	1000	1000	1000	1000	1000	1000	1000	1000	1000
Standardized voltages U <sub>s</sub> at 50/60 Hz	(V)	24...220	24...220	24...220	24...220	24...220	24...220	24...220	24...220	24...220
Single-frequency coil voltage limits										
Operation	xU <sub>s</sub>	0.85...1.1	0.85...1.1	0.85...1.1	0.85...1.1	0.85...1.1	0.85...1.1	0.85...1.1	0.85...1.1	0.85...1.1
Off	xU <sub>s</sub>	0.22...0.55	0.22...0.55	0.22...0.55	0.22...0.55	0.22...0.55	0.22...0.55	0.22...0.55	0.22...0.55	0.22...0.55
Consumption of dual-frequency coils (1)										
Closed magnetic circuit (50 Hz/60 Hz)	(VA)	19	19	20	25	35	38	53	100	190
Open magnetic circuit (50 Hz/60 Hz)	(VA)	27	27	38	41	57	60	90	440	1400
Dissipated thermal power (50 Hz/60 Hz)	(W)	19	19	20	25	35	38	53	100	190
On and off times. Values at U <sub>s</sub>										
Making time at de-energisation (NA)	(ms)	60/70	60/70	60/70	110/120	150/160	180/200	200/210	150/160	-
Making time at de-energisation (NA)	(ms)	80/95	80/95	80/95	160/170	200/210	350/450	240/250	150/160	-
Mechanical endurance										
Dual-frequency coils (at 50 Hz)	10 <sup>6</sup> ops.	10	10	10	10	10	10	10	8	8
Maximum rate										
Dual-frequency coils. No-load	ops./h	1200	1200	600	400	400	400	400	300	300
AC-1 with rated power	ops./h	600	600	300	120	120	120	120	90	60
AC-2 with rated power	ops./h	250	250	200	120	120	120	120	90	-
AC-3 with rated power	ops./h	600	600	300	120	120	120	120	90	-
AC-4 with rated power	ops./h	150	150	100	60	60	60	60	30	-
<b>Direct current</b>										
Rated isolation voltage U <sub>i</sub>	(V)	1000	1000	1000	1000	1000	1000	1000	1000	1000
Standardized voltages U <sub>s</sub>	(V)	24...230	24...230	24...230	24...230	24...230	24...230	24...230	24...230	24...230
Voltage limits										
Operating	xU <sub>s</sub>	0.8...1.1	0.8...1.1	0.8...1.1	0.8...1.1	0.8...1.1	0.8...1.1	0.8...1.1	0.8...1.1	0.8...1.1
Off	xU <sub>s</sub>	0.15...0.5	0.15...0.5	0.15...0.5	0.15...0.5	0.15...0.5	0.15...0.5	0.15...0.5	0.15...0.5	0.15...0.5
Power consumption										
Closed magnetic circuit	(W)	14	14	16	22	28	30	42	80	140
Open magnetic circuit	(W)	21	21	25	31	45	46	65	400	1000
On and off time										
Values at U <sub>s</sub>										
Making time at energization (NA)	(ms)	60/70	60/70	60/70	110/120	150/160	180/200	200/210	150/160	-
Breaking time at de-energization (NA)	(ms)	19/20	19/20	19/20	28/30	40/45	59/60	30/35	25/30	-
Mechanical endurance	10 <sup>6</sup> ops.	10	10	10	10	10	10	10	8	8
Maximum rate										
No-load	ops./h	1200	1200	600	400	400	400	400	300	300
AC1 and AC3 with rated power	ops./h	600	600	300	120	120	120	120	90	-
AC4 with rated power	ops./h	150	150	100	60	60	60	60	30	-

(1) With 5/2 contact

Technical data

Intro

A

B

C

D

E

F

G

H

I

J/X



Dimensional drawings

R1..., R2...

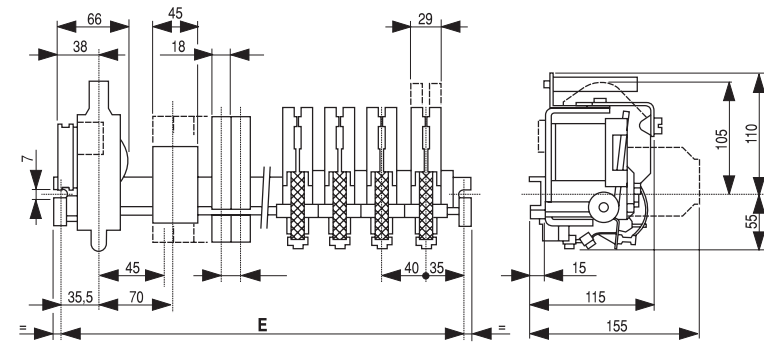

Contact combination

"Z" main pole (1)	Max. no. of aux. contacts	Max. NO	Max. NC	Center-to-center spacing
1	1	1	1	150
	3	3	3	200
	6	6	4	250
	9	6	4	300
	10	6	4	350
2	10	6	4	400
	1	1	1	200
	4	4	4	250
	7	6	4	300
	9	6	4	350
3	9	6	4	400
	2	2	2	250
	5	5	4	300
	7	6	4	350
	7	6	4	400
4	2	2	2	300
	5	5	4	350
	5	5	4	400

(1) A "RN" pole can be used to replace one of the "Z" poles. To use a higher number of "RN" poles, contact the manufacturer.

R3...

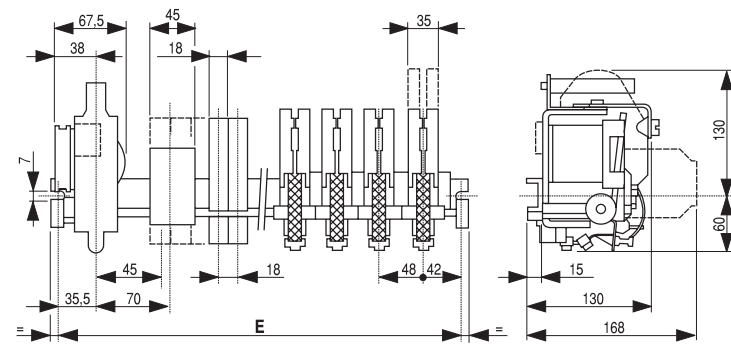

Contact combination

"Z" main pole (1)	Max. no. of aux. contacts	Max. NO	Max. NC	Center-to-center spacing
1	-	-	-	150
	3	3	3	200
	6	6	4	250
	9	6	4	300
	10	6	4	350
2	10	6	4	400
	-	-	-	200
	3	3	3	250
	6	6	4	300
	8	6	4	350
3	9	6	4	400
	-	-	-	250
	3	3	3	300
4	6	6	4	350
	7	6	4	400
	-	-	-	300
	3	3	3	350
	4	4	4	400

(1) A "RN" pole can be used to replace one of the "Z" poles. To use a higher number of "RN" poles, contact the manufacturer.

R4...

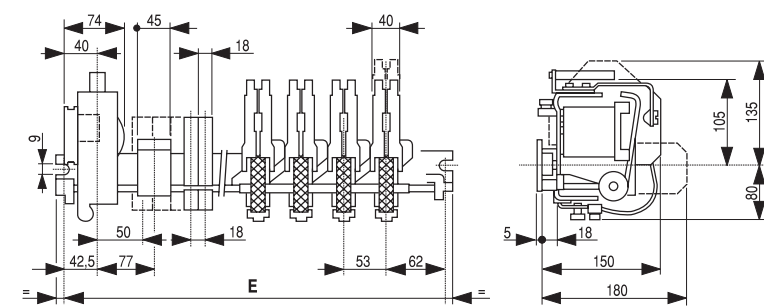

Contact combination

"Z" main pole (1)	Max. no. of aux. contacts	Max. NO	Max. NC	Center-to-center spacing
1	3	3	3	250
	6	6	4	300
	9	6	4	350
	10	6	4	400
	10	6	4	450
2	10	6	4	450
	-	-	-	250
	3	3	3	300
	6	6	4	350
	9	6	4	400
3	10	6	4	450
	-	-	-	300
	3	3	3	350
	6	6	4	400
	9	6	4	450
4	3	3	3	400
	4	4	3	450

(1) A "RN" pole can be used to replace one of the "Z" poles. To use a higher number of "RN" poles, contact the manufacturer.



R5...

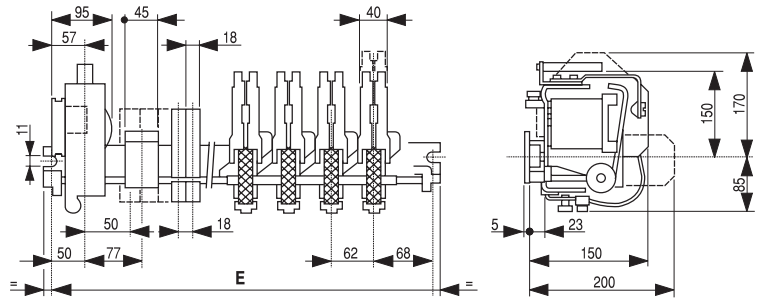

Contact combination

"Z" main pole (1)	Max. no. of aux. contacts	Max. NO	Max. NC	Center-to-center spacing
1	2	2	2	250
	5	5	4	300
	8	6	4	350
	10	6	4	400
	10	6	4	450
2	10	6	4	500
	2	2	2	300
	4	4	4	350
	7	6	4	400
3	10	6	4	450
	10	6	4	500
	1	-	-	350
4	4	4	4	400
	6	6	4	450
	7	6	4	500
-	-	-	-	400
	3	3	3	450
	3	3	3	500

(1) A "RN" pole can be used to replace one of the "Z" poles. To use a higher number of "RN" poles, contact the manufacturer.

R6...

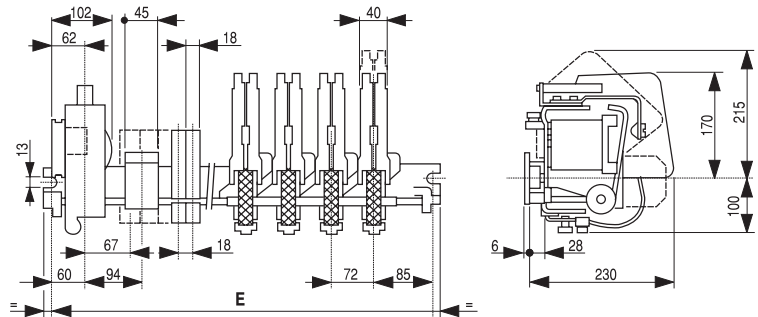

Contact combination

"Z" main pole	Max. no. of aux. contacts	Max. NO	Max. NC	Center-to-center spacing
1	5	2	4	350
	8	6	4	400
	10	6	4	450
	10	6	4	500
	10	6	4	600
2	10	6	4	700
	1	1	1	350
	4	4	4	400
	7	6	4	450
3	9	6	4	500
	10	6	4	600
	10	6	4	700
4	2	2	2	450
	5	5	4	500
	7	6	4	600
	7	6	4	700
-	1	1	1	500
	2	2	2	600
	2	2	2	700

R7...

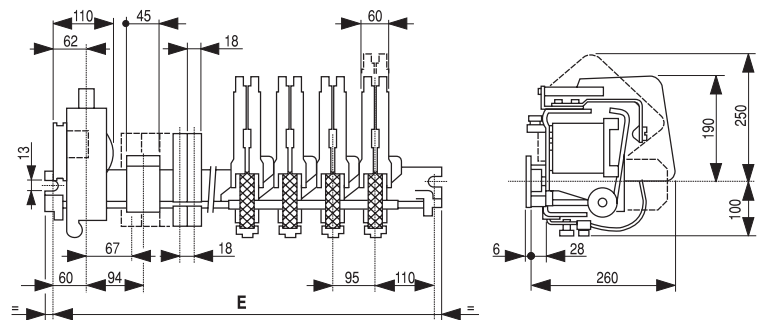

Contact combination

"Z" main pole (1)	Max. no. of aux. contacts	Max. NO	Max. NC	Center-to-center spacing
1	4	4	4	350
	6	6	4	400
	9	6	4	450
	10	6	4	500
	10	6	4	600
2	10	6	4	700
	1	1	1	400
	4	4	4	450
	7	6	4	500
3	10	6	4	600
	10	6	4	700
	1	1	1	500
4	7	6	4	600
	8	6	4	700
	2	2	2	600
-	5	5	3	700

(1) A "RN" pole can be used to replace one of the "Z" poles. To use a higher number of "RN" poles, contact the manufacturer.

Dimensions

Intro

A

B

C

D

E

F

G

H

I

J/X



Dimensional drawings

R8...

"Z" main pole	Max. no. of aux. contacts	Max. NO	Max. NC	Center-to-center spacing
1	1	1	1	350
	4	4	4	400
	6	6	4	450
	9	6	4	500
	10	6	4	600
	10	6	4	700
2	10	6	4	800
	-	-	-	450
	3	3	3	500
	8	6	4	600
3	10	6	4	700
	10	6	4	800
	2	2	2	600
	8	6	4	700
4	8	6	4	800
	1	1	1	700
	4	3	3	800

R9...

"Z" main pole	Max. no. of aux. contacts	Max. NO	Max. NC	Center-to-center spacing
1	2	2	2	400
	4	4	4	450
	7	6	4	500
	10	6	4	600
	10	6	4	700
	10	6	4	800
	10	6	4	900
	10	6	4	1000
2	10	6	4	1000
	4	4	4	600
	9	6	4	700
	10	6	4	800
	10	6	4	900
3	10	6	4	1000
	-	-	-	700
	6	6	4	800
	8	6	4	900
4	8	6	4	1000
	3	3	3	900
	4	3	3	1000

- Clapper contactors
- Intro
- A
- B
- C
- D
- E
- F
- G
- H
- I
- J/X







**Order codes**

- B.2 Series PRC - Plug-in relays
- B.8 Series M - Auxiliary contactors
- B.14 Series RL - Auxiliary contactors

**Series PRC - Plug-in relays**

- B.17 Technical data
- B.24 Dimensions

**Series M - Auxiliary contactors**

- B.26 Technical data
- B.31 Terminal numbering
- B.34 Dimensions

**Series RL - Auxiliary contactors**

- B.36 Technical data
- B.39 Terminal numbering
- B.42 Dimensions

**POWER DEVICES**

Contactors and overload relays

**Auxiliary relays and contactors**

Motor protection devices

Applications

Main switches

**AUXILIARY DEVICES**

Control and signalling units

Electronic relays and limit switches

**POWER ELECTRONICS**

Speed drive units

Soft starters

Lighting dimmer-stabilizer/Numerical index

Intro
A
<b>B</b>
C
D
E
F
G
H
I
J/X





### Plug-in auxiliary relays

- AC or DC coils
- Lockable test button with mechanical flag indicator.
- Sockets with rear 35 mm rail (EN 50022) mounting.
- With LED indicator incorporated.

#### Miniature relays

Types	Poles	AC ratings
PRC4M2...	2 CO	12A/250V
PRC4M3...	3 CO	10A/250V
PRC4M4...	4 CO	6A/250V

#### Sockets

Types
PRCG-ES15/2N
PRCG-ES15/3N
PRCG-ES15/4N

#### Standard 8-11 pin relays

Types	Poles	AC ratings
PRC2P2...	2 CO	10A/250V
PRC3P3...	3 CO	10A/250V

#### Sockets

Types
PRZ8
PRZ11

#### Interface relay module

Types	Poles	AC ratings
PRC1S1...	1 CO	6A/250V
<b>For use with PLC systems</b>		
PRC1T1...	1 CO	16A/250V
PRC1T2...	2 CO	8A/250V

#### Sockets

Types
-
PRCGZT80
PRCGZT80

### Approvals

According to types:

Plug-in relays	Sockets
CE	CE
cUL	cUL
VDE	

### Catalogue number structure

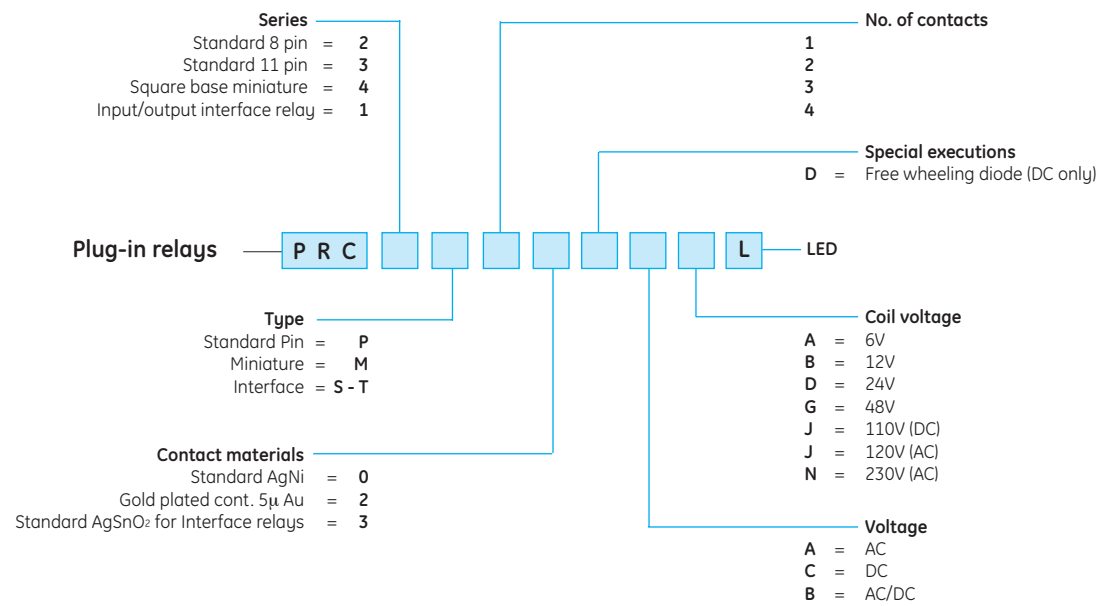

- Order codes ● pg. B.3
- Modules for sockets ● pg. B.6
- Technical characteristics ● pg. B.17
- Dimensions ● pg. B.24



Miniature plug-in relays



	Ratings	Contacts Standard material	Voltage		With LED					
					Cat. no.	Ref. no.	Pack			
2 changeover contacts	12A/250V	0 AgNi	AC 50/60 Hz	12V	PRC4M20ABL	220710	10			
				24V	PRC4M20ADL	220711	10			
				48V	PRC4M20AGL	220712	10			
				120V	PRC4M20AJL	220715	10			
				230V	PRC4M20ANL	220717	10			
				DC	12V	PRC4M20CBL	220713	10		
					24V	PRC4M20CDL	220714	10		
					48V	PRC4M20CGL	220716	10		
				DC Diode	110V	PRC4M20CJL	220718	10		
			12V		PRC4M20DCBL	220754	10			
			24V		PRC4M20DCDL	220755	10			
			48V	PRC4M20DCGL	220756	10				
			110V	PRC4M20DCJL	220757	10				
			3 changeover contacts	10A/250V	0 AgNi	AC 50/60 Hz	12V	PRC4M30ABL	221051	10
							24V	PRC4M30ADL	221052	10
48V	PRC4M30AGL	221053					10			
120V	PRC4M30AJL	221056					10			
230V	PRC4M30ANL	221058					10			
DC	12V	PRC4M30CBL					221054	10		
	24V	PRC4M30CDL					221055	10		
	48V	PRC4M30CGL					221057	10		
DC Diode	110V	PRC4M30CJL					221059	10		
	12V	PRC4M30DCBL				221074	10			
	24V	PRC4M30DCDL				221075	10			
48V	PRC4M30DCGL	221076				10				
110V	PRC4M30DCJL	221077				10				
4 changeover contacts	6A/250V	0 AgNi				AC 50/60 Hz	12V	PRC4M40ABL	221809	10
							24V	PRC4M40ADL	221810	10
			48V	PRC4M40AGL	221811		10			
			120V	PRC4M40AJL	221814		10			
			230V	PRC4M40ANL	221816		10			
			DC	12V	PRC4M40CBL		221812	10		
				24V	PRC4M40CDL		221813	10		
				48V	PRC4M40CGL		221815	10		
			DC Diode	110V	PRC4M40CJL		221817	10		
				12V	PRC4M40DCBL	221851	10			
				24V	PRC4M40DCDL	221852	10			
			48V	PRC4M40DCGL	221853	10				
			110V	PRC4M40DCJL	221854	10				

Sockets



				Cat. no.	Ref. no.	Pack
For PRC4M2... 2 changeover contacts	Screw terminals Two levels	Socket		PRCG-ES15/2N	220912	10
		Fixing clip	Metal	PRCG1052	220914	10
		Retainer/Extractor	White plastic	PRCMS35	220915	10
		Identification plate		PRCTR1	220916	10
For PRC4M3... 3 changeover contacts	Screw terminals Two levels	Socket		PRCG-ES15/3N	221442	10
		Fixing clip	Metal	PRCG1052	220914	10
		Retainer/Extractor	White plastic	PRCMS35	220915	10
		Identification plate		PRCTR1	220916	10
For PRC4M4... 4 changeover contacts	Screw terminals Two levels	Socket		PRCG-ES15/4N	221934	10
		Fixing clip	Metal	PRCG1052	220914	10
		Retainer/Extractor	White plastic	PRCMS35	220915	10
		Identification plate		PRCTR1	220916	10

Order codes

Intro

A

B

C

D

E

F

G

H

I

J/X



Standard 8-11 pin plug-in relays

Plug-in relays

Intro

A

B

C

D

E

F

G

H

I

J/X



Standard 8 pin

Ratings	Contacts Standard material	Voltage	With LED		
			Cat. no.	Ref. no.	Pack
AC					
10A/250V	0 AgNi	AC 50/60 Hz	12V PRC2P20ABL	220019	10
			24V PRC2P20ADL	220020	10
			48V PRC2P20AGL	220021	10
			120V PRC2P20AJL	220024	10
			230V PRC2P20ANL	220026	10
		DC	12V PRC2P20CBL	220022	10
			24V PRC2P20CDL	220023	10
			48V PRC2P20CGL	220025	10
			110V PRC2P20CJL	220027	10
		DC diode	12V PRC2P20DCBL	220041	10
			24V PRC2P20CDL	220042	10
			48V PRC2P20DCGL	220043	10
			110V PRC2P20DCJL	220044	10

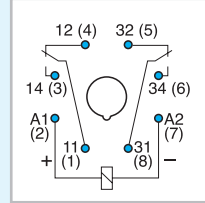

Standard 11 pin

Ratings	Contacts Standard material	Voltage	With LED		
			Cat. no.	Ref. no.	Pack
AC					
10A/250V	0 AgNi	AC 50/60 Hz	12V PRC3P30ABL	220310	10
			24V PRC3P30ADL	220311	10
			48V PRC3P30AGL	220312	10
			120V PRC3P30AJL	220315	10
			230V PRC3P30ANL	220317	10
		DC	12V PRC3P30CBL	220313	10
			24V PRC3P30CDL	220314	10
			48V PRC3P30CGL	220316	10
			110V PRC3P30CJL	220318	10
		DC diode	12V PRC3P30DCBL	220335	10
			24V PRC3P30CDL	220336	10
			48V PRC3P30DCGL	220337	10
			110V PRC3P30DCJL	220338	10

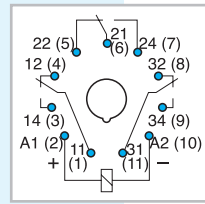

Sockets



For PRC2P20...  
Standard 8 pin

			Cat. no.	Ref. no.	Pack
Screw terminals One level	Socket		PRCZ8	220216	10
	Fixing clip		PRCPZ11	220218	10
Solder terminal	Socket		PRCG8	220217	10
	Fixing clip		PRCR159	220219	10
Screw terminals One level	Socket		PRCZ11	220647	10
	Fixing clip		PRCPZ11	220218	10
Solder terminal	Socket		PRCG11	220648	10
	Fixing clip		PRCR159	220219	10

For PRC3P30...  
Standard 11 pin



Interface relay



1 single pole  
1 changeover contact

Ratings AC1	Ratings DC1	Contacts material	Voltage		With LED		
					Cat. no.	Ref. no.	Pack
6,2mm wide							
6A/250V	-	3 AgSnO <sub>2</sub>	AC/DC	230V	PRC1S13BNL	222013	10
6A/250V	-	3 AgSnO <sub>2</sub>	DC	12V	PRC1S13CBL	222007	10
				24V	PRC1S13CDL	222008	10
			AC/DC	24V	PRC1S13BDL	222004	10

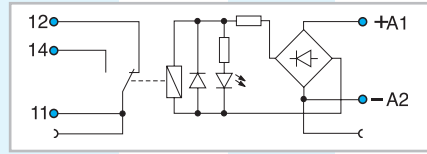

Interface relay for PLC systems

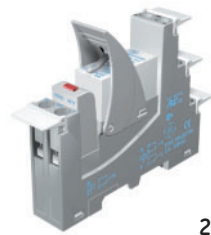

1 changeover contact  
2 changeover contacts

Ratings AC1	Ratings DC1	Contacts material	Voltage		With LED		
					Cat. no.	Ref. no.	Pack
16A/250V	16A/24V	0 AgNi	AC	24V	PRC1T10ADL	221868	10
				120V	PRC1T10AJL	221869	10
				230V	PRC1T10ANL	221870	10
			DC	12V	PRC1T10CBL	221860	10
				24V	PRC1T10CDL	221861	10
				110V	PRC1T10CJL	221862	10
8A/250V	8A/24V	0 AgNi	AC	24V	PRC1T20ADL	221883	10
				120V	PRC1T20AJL	221884	10
				230V	PRC1T20ANL	221885	10
			DC	12V	PRC1T20CBL	221875	10
				24V	PRC1T20CDL	221876	10
				110V	PRC1T20CJL	221877	10

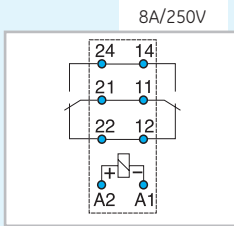
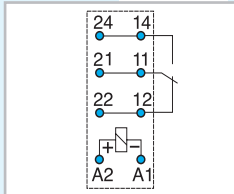

Complete set of relay, socket, module (diode+Led for DC-Varistor + Led for AC) and retaining clip + marking plate.  
16mm width

Spare parts

Miniature P.C.B. relays. 16A  
1 changeover contact



Miniature P.C.B. relays. 8A  
2 changeover contacts



Socket for miniature P.C.B. relays

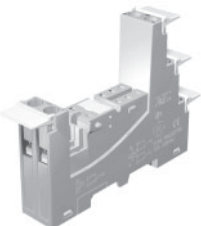

Voltage	Cat. no.	Ref. no.	Pack
AC 50/60 Hz	24V	PRCT1AD	221896 20
	120V	PRCT1AJ	221897 20
	230V	PRCT1AN	221898 20
DC	12V	PRCT1CB	221890 20
	24V	PRCT1CD	221891 20
	110V	PRCT1CJ	221892 20
AC 50/60 Hz	24V	PRCT2AD	221913 20
	120V	PRCT2AJ	221914 20
	230V	PRCT2AN	221915 20
DC	12V	PRCT2CB	221905 20
	24V	PRCT2CD	221906 20
	110V	PRCT2CJ	221907 20
Three level screws	PRCGZT80	221918	10
Retainer/Retractor	PRCMS16	221920	10
Plate	PRCTR	221921	10

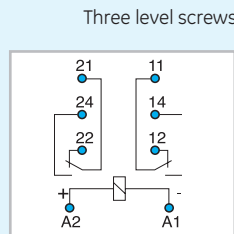

NOTE: If more than 12A are applied to the relay contact, twin wiring is required.  
See the connection diagram of the relay

Order codes

Intro

A

B

C

D

E

F

G

H

I

J/X



Modules for sockets



			Color Led	Cat. no.	Ref. no.	Pack	
<b>Diode</b>	Protection against polarity inversion						
	For use with sockets: PRCG-ES15/2N PRCG-ES15/3N PRCG-ES15/4N			PRCM21P	222100	10	
				PRCM21N	222101	10	
<b>Diode and Led</b>	Protection against polarity inversion Coil energizing indication						
	For use with sockets: PRCG-ES15/2N PRCG-ES15/3N PRCG-ES15/4N PRCGZT80		6 / 24V DC	Red	PRCM31R	222102	10
			24 / 60V DC	Green	PRCM31G	222104	10
			110 / 230V DC	Red	PRCM32R	222103	10
				Green	PRCM32G	222105	10
				Green	PRCM33G	222106	10
				Red	PRCM33R	222109	10
			6 / 24V DC	Green	PRCM41G	222110	10
			24 / 60V DC	Red	PRCM41R	222107	10
				Red	PRCM42R	222111	10
			Green	PRCM42G	222124	10	
	110 / 230V DC	Red	PRCM43R	222112	10		
		Green	PRCM43G	222125	10		
<b>RC group</b>	Arc suppression circuit						
	For use with sockets: PRCG-ES15/2N PRCG-ES15/3N PRCG-ES15/4N		6 / 24V AC		PRCM51	222113	10
			24 / 60V AC		PRCM52	222114	10
			110 / 240V AC		PRCM53	222115	10
<b>Led and varistor</b>	No protection against polarity inversion Coil energizing indication AC/DC voltage allowed						
	For use with sockets: PRCG-ES15/2N PRCG-ES15/3N PRCG-ES15/4N PRCGZT80		6 / 24V AC	Red	PRCM91R	222116	10
			110 / 230V AC	Green	PRCM91G	222126	10
			Green	PRCM93G	222120	10	
<b>Varistor group</b>	No indication Protection against overvoltage						
	For use with sockets: PRCG-ES15/2N PRCG-ES15/3N PRCG-ES15/4N		24V AC		PRCM71	222121	10
			230V AC		PRCM73	222122	10

Plug-in relays

Intro

A

B

C

D

E

F

G

H

I

J/X





Notes

Grid of dotted lines for notes.

Order codes

Intro

A

**B**

C

D

E

F

G

H

I

J/X



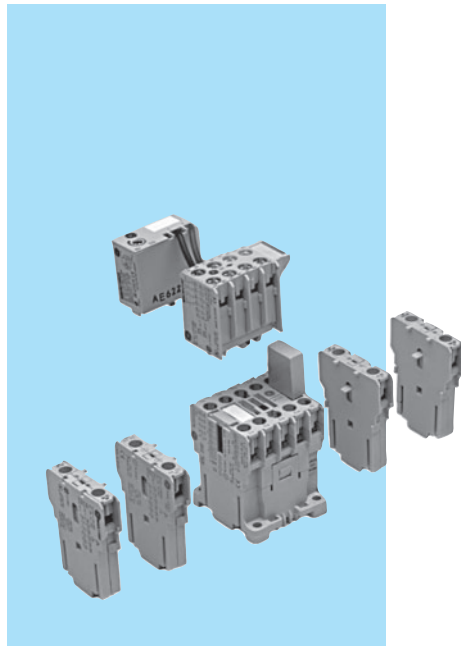

### Auxiliary contactors Ith = 16A

- Control circuit: Alternating current up to 600V  
Direct current up to 250V
- Terminal numbering in accordance with EN 50011
- Fixing system for rapid and simple mounting by clamping onto standard 35 mm DIN rail (EN 50022).
- Screw and push-on terminals protected against accidental contacts in accordance with VDE 0106 T.100 and VBG4.
- Printed circuit version.
- Ring terminal version.
- Facility to mount instant or timed auxiliary contact blocks and voltage suppressor blocks.
- Maximum number of auxiliary contacts to add: 6
- Degree of protection IP20 (EN 60529).
- According to IEC/EN 60947-1.

#### Standards

IEC/EN 60947-5-1	BS 4794
IEC/EN 60947-1	CENELEC HD 420
EN 50002	NFC 63-110
EN 50005	NFC 63-140
EN 50011	CSA C22.2/14
UL 508	VDE 0660

#### General data

Maximum number of contacts (MCR...)	4
Rated thermal current (Ith) $\theta \leq 60^\circ$	(A) 16
Rated operational voltage (Ue) acc. IEC 60947-1	(V) 690
Insulation voltage (Ui) acc. IEC 60947-1	(V) 750

#### Utilisation category:

AC-15	V	110	220/240	380/400	415	440	500	660/690
	A	6	6	4	4	3	2.5	1.5

DC-13	V	24	48	110	220
	A	5	3.5	1.2	0.6

#### Approvals

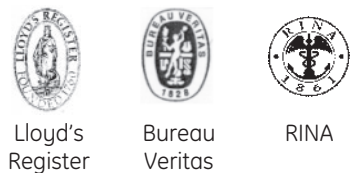

#### Standard voltages

To complete the catalogue number, replace the symbol  $\blacklozenge$  by the code corresponding to the voltage and frequency of the control circuit.

#### Alternating current (V). Bifrequency coil

$\blacklozenge$	10	1	2	9	3	4	5	6	7	8	12	13
AC	12	24	42	48	110	120	220	230	240	440	380	400
50/60Hz				115								

#### Voltage operating limits of dual-frequency coil:

at 60Hz =  $0.85 \alpha 1.1 \times U_s$   
at 50Hz =  $0.8 \alpha 1.1 \times U_s$  for uninterrupted duty (ED=100%), temperature = 40°C

#### Alternating current (V)

$\blacklozenge$	A	E	G	K	M	N	S	U	W	Y
AC			48	115		220	260	380	415	500
50Hz				127		240		400	440	
AC	6	32	60		208	240		440	480	600
60Hz					220	277				

#### Direct current (V)

$\blacklozenge$	A	B	C	D	E	F	G	H	I	J	K	L	N	17	R	S	16
DC	6	12	32	24	36	42	48	60	72	110	120	125	220	230	240	250	440

#### Direct current (V) - Wide voltage range



$\blacklozenge$	WD	WE	WG	WI	WJ	WN
DC	24	33	48	72	110	220

- Order codes ● pg. B.9
- Auxiliary contacts blocks ● pg. B.10
- Accessories ● pg. B.12
- Technical data ● pg. B.26
- Dimensions ● pg. B.34





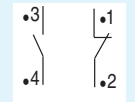

Auxiliary contactors

Contacts acc. to EN 50011	Control circuit: alternating current			Control circuit: direct current		
	Cat. no. <sup>(1)</sup>	Ref. no. see bottom	Pack	Cat. no. <sup>(1)</sup>	Ref. no. see bottom	Pack
						
<b>Screw terminal</b>						
40E	4 0	MCRA040AT	5	MCRC040AT		10
31E	3 1	MCRA031AT	5	MCRC031AT		10
22E	2 2	MCRA022AT	5	MCRC022AT		10
13E	1 3	MCRA013AT	5			
04E	0 4	MCRA004AT	5			
<b>Ring terminal</b>						
40E	4 0	MCRA040AR	5	MCRC040AR		10
31E	3 1	MCRA031AR	5	MCRC031AR		10
22E	2 2	MCRA022AR	5	MCRC022AR		10
13E	1 3	MCRA013AR	5			
04E	0 4	MCRA004AR	5			
<b>Terminal: faston 2x2,8 insulated <sup>(2)</sup></b>						
40E	4 0	MCRA040AF	5	MCRC040AF		10
31E	3 1	MCRA031AF	5	MCRC031AF		10
22E	2 2	MCRA022AF	5	MCRC022AF		10
13E	1 3	MCRA013AF	5			
04E	0 4	MCRA004AF	5			
<b>Terminal: printed circuit</b>						
40E	4 0	MCRA040AI	5	MCRC040AI		10
31E	3 1	MCRA031AI	5	MCRC031AI		10
22E	2 2	MCRA022AI	5	MCRC022AI		10
13E	1 3	MCRA013AI	5			
04E	0 4	MCRA004AI	5			
	Spare coil		MB0A	10	MB0C	10

(1) To complete the catalogue number, replace the symbol ♦ by the code corresponding to the voltage and frequency of the control circuit. (see pg.A.16).  
 (2) Terminal: - with wire 1.5 mm<sup>2</sup>; le = 16A - with wire 1 mm<sup>2</sup>; le = 10A  
 Insulated terminal type B2.8x0.8 with wire 1 mm<sup>2</sup>; le = 8A to DIN 46247  
 Faston terminal 1 x 6.3 on request, replace the letter F by H in the catalogue number

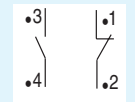
Auxiliary contactors interface

Contacts acc. to EN 50011	Control circuit: direct current 24V / 1.2W <sup>(3)</sup>			Control circuit: direct current 24V / 2W <sup>(4)</sup>			
	Operating limits from 19 to 30V (0.8-1.25xUs)			Operating limits from 17 to 30V (0.7-1.25xUs)			
	Cat. no.	Ref. no.	Pack	Cat. no.	Ref. no.	Pack	
							
<b>Screw terminal</b>							
40E	4 0	MCRI040ATD	100530	10	MCRK040ATD	100533	
31E	3 1	MCRI031ATD	100531	10	MCRK031ATD	100534	
22E	2 2	MCRI022ATD	100532	10	MCRK022ATD	100535	
	Spare coil		MB0ID	100470	10	MB0KD	100471

(3) No possibility of adding instantaneous auxiliary blocks.  
 (4) Facility to mount instantaneous auxiliary contact block of two contacts (MARN2...) or two instantaneous auxiliary contact blocks of one contact (MARL1...).

For reference numbers, see chapter X, pg. X.6

Order codes

Intro

A

B

C

D

E

F

G

H

I

J/X



**Instantaneous auxiliary contacts blocks**

Front mounting



Number of contacts	Combination with MCRA040AT (40E) according to EN 50011	Designation (block marking)	Contacts acc. to EN 50005		Cat. no.	Ref. no.	Pack
			•3	•1			
<b>Screw terminal</b>							
2	60E	20	2	0	MARN220AT	100994	10
2	51E	11	1	1	MARN211AT	100993	10
2	42E	02	0	2	MARN202AT	100992	10
<b>Ring terminal</b>							
2	60E	20	2	0	MARN220AR	103349	10
2	51E	11	1	1	MARN211AR	103350	10
2	42E	02	0	2	MARN202AR	103351	10
<b>Screw terminal</b>							
4	80E	40	4	0	MARN440AT	100991	10
4	71E	31	3	1	MARN431AT	100990	10
4	62E	22	2	2	MARN422AT	100989	10
4	53E	13	1	3	MARN413AT	100988	10
4	44E	04	0	4	MARN404AT	100987	10
<b>Terminal : Ring terminal</b>							
4	80E	40	4	0	MARN440AR	103352	10
4	71E	31	3	1	MARN431AR	103353	10
4	62E	22	2	2	MARN422AR	103354	10
4	53E	13	1	3	MARN413AR	103355	10
4	44E	04	0	4	MARN404AR	103300	10



Instantaneous auxiliary contacts blocks

Lateral mounting



Number of contacts	Combination with MCRA040AT (40E) according to EN 50011	Contacts acc. to EN 50005			Cat. no.	Ref. no.	Pack
		Designation (Block marking)	•3	•1			
<ul style="list-style-type: none"> <li>One or two blocks to cover combinations of 5 or 6 contacts without increasing the height of the basic unit.</li> </ul>							
<b>Screw terminal</b>							
1	50E	10	1	0	MARL110AT	100513	10
1	-	01	0	1	MARL101AT	100514	10
<b>Ring terminal</b>							
1	50E	10	1	0	MARL110AR	103556	10
1	-	01	0	1	MARL101AR	103557	10
<b>Terminal : Faston 2x2,8 insulated (1)</b>							
1	50E	10	1	0	MARL110AF	100515	10
1	-	01	0	1	MARL101AF	100516	10
<b>Terminal : Printed circuit</b>							
1	50E	10	1	0	MARL110AI	100517	10
1	-	01	0	1	MARL101AI	100518	10
<ul style="list-style-type: none"> <li>One or two additional blocks, when 9 or 10 contacts are required (combination possible with the front mounting block)</li> <li>One or two additional blocks on both sides, to cover up to 8 contacts (combination only possible with lateral blocks)</li> </ul>							
<b>Screw terminal</b>							
1	50E	10	1	0	MARL110ATS	100519	10
1	-	01	0	1	MARL101ATS	100520	10
<b>Ring terminal</b>							
1	50E	10	1	0	MARL110ARS	103299	10
1	-	01	0	1	MARL101ARS	103298	10
<b>Terminal : Faston 2x2,8 insulated (1)</b>							
1	50E	10	1	0	MARL110AFS	100521	10
1	-	01	0	1	MARL101AFS	100522	10
<b>Terminal : Printed circuit</b>							
1	50E	10	1	0	MARL110AIS	100523	10
1	-	01	0	1	MARL101AIS	100524	10

(1) Terminal with wire 1 mm<sup>2</sup>: Ie = 10A  
Insulated terminal type B2.8x0.8 with wire 1 mm<sup>2</sup>: Ie = 8A

Order codes

Intro

A

**B**

C

D

E

F

G





H

I

J/X



Accessories

	For use with:	Time	Function	Ue	Cat. no.	Ref. no.	Pack
 <p><b>Electronic timer block</b></p>	Lateral or front fixing on the contactor						
	MCR, MC ...	0.5 - 60 sec.	Delay ON	24 to 250V AC/DC	MREBC10AC2	100541	10
	MCR, MC ...	0.2 - 24 sec.	Delay ON	24 to 250V AC/DC	MREBC20AC2	100542	10
 <p><b>Timer fitment</b></p>	For fixing onto 35mm DIN-rail (EN 5022)						
	MREBC...				MVB0R	100543	10
 <p><b>Voltage suppressor block</b></p>	Connection and (plug-in) fixing onto front of the contactor						
	MCRA, MC ...	RC	AC	12 to 60V 50/60Hz	MP0AAE1	100544	10
	MCRA, MC ...	RC	AC	72 to 250V 50/60Hz	MP0AAE2	100545	10
	MCR, MC ...	Diode	DC	6 to 250V DC	MP0CAE3	100546	10
	MCR, MC ...	Varistor	AC/DC	24-48V	MP0DAE4	100536	10
 <p><b>Mechanical interlock</b></p>	For use with:				Cat. no.	Ref. no.	Pack
	Kit comprising mechanical interlock and contactor jointing parts						
	MCR, MC ...				MMH0	100547	10
<p><b>Identification</b></p>	For use with:				Cat. no.	Ref. no.	Pack
	MCR, MC ...	Sheets of labels (10 sheets of 260 labels each)			EAT 260	100548	1
	MCR, MC ...	Labelling plate base, Plug-in labelling plate bases (50 pieces in one pack)			SPR	100549	1



Notes

Grid of dotted lines for notes.

Order codes

Intro
A
<b>B</b>
C
D
E
F
G
H
I
J/X



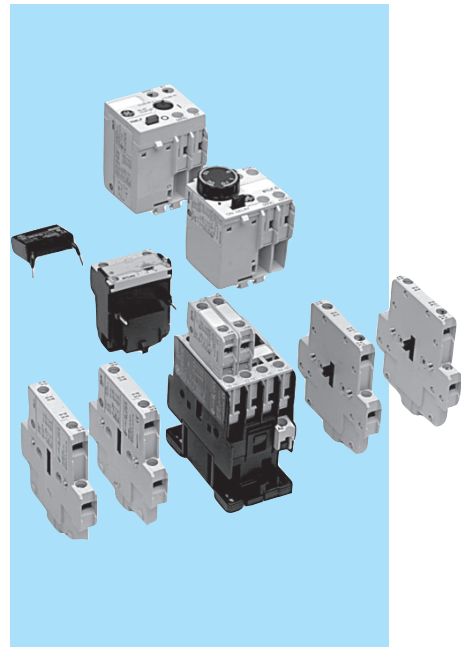

## Auxiliary contactors *I<sub>th</sub>* = 20A

- Control circuit: Alternating current up to 690V  
Direct current up to 440V
- Terminal numbering in accordance with EN 50005 and EN 50011
- Fixing system for rapid and simple mounting onto standard 35mm DIN-rail (EN 50022-35)
- Terminals protected against accidental contact in accordance with VDE 0106 T.100, VBG4
- Ring terminal versions
- Three coil terminals
- Facility to mount side and/or front instantaneous contact blocks, timed auxiliary contacts, mechanical latch, voltage suppressor blocks and interface modules.
- Degree of protection IP20 (EN 60529)

### Standards

IEC/EN 60947-5-1	BS 4794
IEC/EN 60947-1	CENELEC HD410
EN 90947	CENELEC HD420
EN 60947	NFC 63-110
EN 50005	NFC 63-140
EN 50011	CSA C22.2/14
UL 508	VDE 0660/102
NEMA ICS 1	

### General data

<b>Maximum number of contacts (RL...)</b>	4
<b>Rated thermal current (<i>I<sub>th</sub></i>) <math>\theta \leq 55^\circ</math></b>	(A) 20
<b>Rated operational voltage (<i>U<sub>e</sub></i>)</b>	(V) 690
<b>Insulation voltage (<i>U<sub>i</sub></i>)</b>	(V) 1000

#### Utilisation category:

AC-15	V	120	230/220	400/380	440/415	500	690/660
	A	10	10	6	5	4	2

DC-13	V	24	48	110	220	440
	A	6	4	2	0.7	0.35

### Approvals

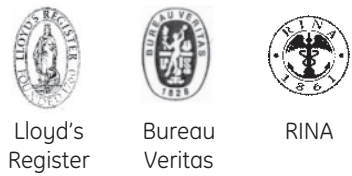

### Standard voltages

To complete the catalogue number, replace the symbol  $\blacklozenge$  by the code corresponding to the voltage and frequency of the control circuit.

#### Alternating current (V). Dual-frequency coil

$\blacklozenge$	1	2	9	3	4	5	6	7	13	8	15
AC	24	42	48	110	120	220	230	240	400	440	480
50/60Hz			115								

#### Alternating current (V)

$\blacklozenge$	A	B	E	K	L	N	T	U	W	Y	Z
AC			32	127		220		380	415	500	660
50Hz						230		400		690	
AC	6	12			208	277	380	480	460	600	
60Hz											

#### Direct current (V)

$\blacklozenge$	B	D	E	F	G	H	I	J	K	N	P	R	T
DC	12	24	36	42	48	60	72	110	120	220	230	240	250

#### Direct current (V) - Wide voltage range

$\blacklozenge$	WB	WD	WE	WF	WG	WH	WI	WJ	WK	WN	WP	WR	WT
DC	12	24	33	42	48	60	72	110	125	220	230	240	250

Order codes ● pg. B.15  
Accessories ● pg. B.16  
Technical data ● pg. B.36  
Dimensions ● pg. B.42



Auxiliary contactors



Contacts				Control circuit: Alternating current up to 690V			Control circuit: Direct current up to 440V		
				Cat. no. <sup>(1)</sup>	Ref. no. see bottom	Pack	Cat. no. <sup>(1)</sup>	Ref. no. see bottom	Pack
<b>Screw terminal</b>									
4	0	0	0	RL4RA040T	◆	5	RL4RD040T	◆	10
3	1	0	0	RL4RA031T	◆	5	RL4RD031T	◆	10
2	2	0	0	RL4RA022T	◆	5	RL4RD022T	◆	10
0	4	0	0	RL4RA004T	◆	5	RL4RD004T	◆	10
1	1	1	1	RL4RA022G	◆	5	RL4RD022G	◆	10
<b>Ring terminal</b>									
4	0	0	0	RL4RA040R	◆	5	RL4RD040R	◆	10
3	1	0	0	RL4RA031R	◆	5	RL4RD031R	◆	10
2	2	0	0	RL4RA022R	◆	5	RL4RD022R	◆	10
0	4	0	0	RL4RA004R	◆	5	RL4RD004R	◆	10
<b>Spare coil</b>									
<b>Screw terminal</b>									
				LB1A	◆	5	LB1D	◆	5
<b>Ring terminal</b>									
				LR1A	◆	5	LR1D	◆	5

(1) To complete the catalogue number, replace the symbol ◆ by the code corresponding to the voltage and frequency of the control circuit. (see pg. B.14).

Auxiliary contacts

Instantaneous		Number of contacts	Contacts	Function	Time	Cat. no.	Ref. no.	Pack		
<b>Frontal mounting</b>		<b>Screw terminal</b>								
	1	1	0	0	0	BCLF10	104700	10		
	1	0	1	0	0	BCLF01	104701	10		
	1	0	0	1	0	BCLF10G	104702	10		
	1	0	0	0	1	BCLF01G	104703	10		
		<b>Ring terminal</b>								
	1	1	0	0	0	BCRF10	108901	10		
	1	0	1	0	0	BCRF01	108902	10		
<b>Side mounting</b>		<b>Screw terminal</b>								
	2	2	0	0	0	BRLL20	104704	10		
	2	1	1	0	0	BRLL11	104705	10		
	2	0	2	0	0	BRLL02	106622	10		
<b>Pneumatic timer blocks</b>		<b>Frontal mounting</b>								
		<b>Screw terminal</b>								
	2	0	0	1	1	Delayed ON	0.1 - 30 sec.	BTLF30C	104709	10
	2	0	0	1	1	Delayed ON	1 - 60 sec.	BTLF60C	104710	10
	2	0	0	1	1	Delayed OFF	0.1 - 30 sec.	BTLF30D	104711	10
	2	0	0	1	1	Delayed OFF	1 - 60 sec.	BTLF60D	104712	10
		<b>Ring terminal</b>								
	2	0	0	1	1	Delayed ON	0.1 - 30 sec.	BTRF30C	108903	10
	2	0	0	1	1	Delayed ON	1 - 60 sec.	BTRF60C	108904	10
	2	0	0	1	1	Delayed OFF	0.1 - 30 sec.	BTRF30D	108905	10
	2	0	0	1	1	Delayed OFF	1 - 60 sec.	BTRF60D	108906	10
Sealing cover protection for pneumatic timer						BTLFX	113001	5		

For reference numbers, see chapter X, pg. X.7



Order codes

Intro

A

B

C

D

E

F

G

H

I

J/X

**Accessories**

	Number of contacts	Contacts				Cat. no.	Ref. no.	Pack
		•3 •4	•1 •2	•7 •8	•5 •6			
<b>Mechanical interlock</b>	Mechanical	-	-	-	-	BELA	104723	5
	Mechanical / electrical	2	0	2	-	BELA02	104724	5



<b>Mechanical latch blocks</b>	Frontal mounted to the contactor							
		RL4RA..., RL4RD...	RMLF ♦ <sup>(1)</sup>	see bottom	20			



(1) To complete the catalogue number, replace the symbol ♦ by the code corresponding to the voltage and frequency of the control circuit.

	D	G	HC	J	N	U	Y
50Hz	24, 32	42, 48		110, 115, 120, 127	220, 230, 240	380, 400, 415, 440, 480	500, 660/690
60Hz	24, 32	48, 60		110, 115, 120, 127	208, 220, 240, 277	380, 400, 415, 440, 480	600
DC	24, 32, 36	42, 48, 60, 72		110, 120, 125	220, 230, 240, 250	440	

	For use with:	Type	Control circ.	Ue	Cat. no.	Ref. no.	Pack
<b>Transient voltage suppressor block</b>	Directly connected parallel to the coil terminals, allows simultaneous use with auxiliary contact blocks.						
	RL4RA...	R/C	AC	12V ... 48V	BSLR2G	104713	10
	RL4RA...	R/C	AC	50V ... 127V	BSLR2K	104714	10
	RL4RA...	R/C	AC	130V ... 250V	BSLR2R	104715	10
	RL4RD...	Diode	DC	12V ... 600V	BSLDZ	104719	10
	RL4RA..., RL4RD...	Varistor	AC / DC	24V ... 48V	BSLV3G	104720	10
	RL4RA..., RL4RD...	Varistor	AC / DC	50V ... 127V	BSLV3K	104721	10
	RL4RA..., RL4RD...	Varistor	AC / DC	130V ... 250V	BSLV3R	104722	10
	RL4RA..., RL4RD...	Varistor	AC / DC	277V ... 500V	BSLV3U	110836	10



	For use with:		Cat. no.	Ref. no.	Pack
<b>Identification</b>	RL4RA..., RL4RD...	Sheets of labels (10 sheets of 260 labels each)	EAT 260	100548	1
	RL4RA..., RL4RD...	Labelling plate base. Plug-in labelling plate bases (50 pieces in one pack)	SPR	100549	1

	For use with:	Control circuit	Function	Time	Cat. no.	Ref. no.	Pack
<b>Electronic timer module</b>	Directly connected parallel to the coil terminals, allows simultaneous use with auxiliary contact blocks.						
	RL4...	24-250V AC/DC	Delayed ON	0,1 - 2 sec.	BETL02C	113602	5
	RL4...	24-250V AC/DC	Delayed ON	1,5 - 45 sec.	BETL45C	113603	5
	RL4...	24-250V AC/DC	Delayed OFF	0,1 - 2 sec.	BETL02D	113604	5
	RL4...	24-250V AC/DC	Delayed OFF	1,5 - 45 sec.	BETL45D	113605	5

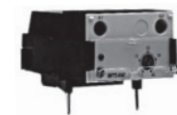

For reference numbers, see chapter X, pg. X.7





Technical data

Sockets for miniature plug-in relays

		PRCG-ES15/2N	PRCG-ES15/3N	PRCG-ES15/4N
		Screw terminals two levels	Screw terminals two levels	Screw terminals two levels
<i>Specifications</i>				
Nominal load	(A)	12 (300V)	10 (300V)	10 (300V)
<i>Dielectric strength</i>				
Adjacent screws	(kV)	3	3	3
Screws - rail	(kV)	3	3	3
<i>Terminals</i>				
Type		Screw M4, Pozidriv	Screw M4, Pozidriv	Screw M3, Pozidriv
Max. torque	(Nm)	0,7	0,7	0,7
Protection category		IP20	IP20	IP20
Capacity				
Solid wire	(mm <sup>2</sup> )	2x2.5	2x2.5	2x2.5
Flexible wire		22-14 AWG	22-14 AWG	22-14 AWG
Ambient temperature	(°C)	-40 ... +70	-40 ... +70	-40 ... +70

Sockets for 8-11 pin standard plug-in relays

		PRCZ8	PRCG08	PRCZ11	PRCG11
		Screw terminals One level	8 pin Solder terminal socket	Screw terminals One level	11 pin Solder terminal socket
<i>Specifications</i>					
Nominal load	(A)	10 (250V)	10 (250V)	10 (250V)	10 (250V)
<i>Dielectric strength</i>					
Adjacent screws	(kV)	2.5	2.5	2.5	2.5
Screws - rail	(kV)	3		3	
<i>Terminals</i>					
Type		Screw M3, Pozidriv	Hard brass tin-plated terminals	Screw M3, Pozidriv	Hard brass tin-plated terminals
Max. torque	(Nm)	0,7		0,7	
Protection category		IP20		IP20	
Capacity					
Solid wire	(mm <sup>2</sup> )	2x2.5		2x2.5	
Flexible wire		22-14 AWG		22-14 AWG	
Ambient temperature	(°C)	-40 ... +70		-40 ... +70	

Sockets for miniature P.C.B. relays

		PRCGZ80
		Screw terminals Two levels
<i>Specifications</i>		
Nominal load	(A)	12 (300V)
<i>Dielectric strength</i>		
Adjacent screws	(kV)	3
Screws - rail	(kV)	3
<i>Terminals</i>		
Type		Screw M4, Pozidriv
Max. torque	(Nm)	0,7
Protection category		IP20
Capacity		
Solid wire	(mm <sup>2</sup> )	2x2.5
Flexible wire		22-14 AWG
Ambient temperature	(°C)	-40 ... +70

Technical data

Intro

A

**B**

C

D

E

F

G

H

I

J/X



Miniature plug-in relays

		PRC4M20...	PRC4M30...	PRC4M40...
		2 pole	3 pole	4 pole
<b>Contacts</b>				
Number of contacts		2 changeover	3 changeover	4 changeover
Standard material		AgNi	AgNi	AgNi
Optional material		AgNi/Au 5μ	AgNi/Au 5μ	AgNi/Au 5μ
<b>Voltage</b>				
Max. switching voltage AC/DC (poll. 3)		250V	250V	250V
voltage AC (poll. 2)		400V	400V	400V
Min. switching voltage AC/DC		5V	5V	5V
<b>Current</b>				
Rated load	AC1 (A)	12 (250V AC)	10 (250V AC)	6 (250V AC)
	AC15 (A)	4 (250V AC)	4 (250V AC)	2,5 (250V AC)
	DC1 (A)	12 (24V DC)	10 (24V DC)	6 (24V DC)
Min. switching current	(mA)	5	5	5
Max. inrush current	(A)	24	20	12
Rated current	(A)	12	10	6
Max. breaking capacity	(VA)	3000	2500	1500
Resistance	(mΩ)	≤100 (100mA, 24V)	≤100 (100mA, 24V)	≤100 (100mA, 24V)
<b>Max. operating frequency</b>				
At rated load	cycles/hour	1200	1200	1200
No load	cycles/hour	18000	18000	18000
<b>Coil</b>				
Rated voltage	AC 50/60Hz (V)	6 ... 240	6 ... 240	6 ... 240
	DC (V)	5 ... 220	5 ... 220	5 ... 220
Must release time	AC	≥0.2 Un	≥0.2 Un	≥0.2 Un
voltage	DC	≥0.1 Un	≥0.1 Un	≥0.1 Un
Operating range of supply voltage		Table 1, 2	Table 1, 2	Table 1, 2
Rated power consumption	AC 50Hz (VA)	1.5	1.6	1.6
	60Hz (VA)	1.3	1.3	1.3
	DC (W)	0.9	0.9	0.9
	AC/DC (W)	-	-	-
<b>Insulation</b>				
Insulation category		C250	C250	B250
Insulation rated voltage	(VAC)	250	250	250
Dielectric strength	Coil-Contact (VAC)	2500	2500	2500
	Contact-Contact (VAC)	1500	1500	1500
	Pole-Pole (VAC)	2500	2500	2000
Contact coil distance	Clearance (mm)	≥ 2.5	≥ 2.5	≥ 1.6
	Creepage (mm)	≥ 4	≥ 4	≥ 3.2
<b>General data</b>				
Operating time (typical value)	AC (ms)	10	10	10
	DC (ms)	13	13	13
Release time (typical value)	AC (ms)	8	8	8
	DC (ms)	3	3	3
Electrical life	Resistive	≥ 10 <sup>5</sup> (12A, 250V AC)	≥ 10 <sup>5</sup> (10A, 250V AC)	≥ 10 <sup>5</sup> (6A, 250V AC)
	Cos φ	See curves	See curves	See curves
Mechanical life (cycles)		≥ 10 <sup>7</sup>	≥ 10 <sup>7</sup>	≥ 10 <sup>7</sup>
Ambient temperature	Storage (°C)	-40 ... +85	-40 ... +85	-40 ... +85
	Operating AC (°C)	-40 ... +55	-40 ... +55	-40 ... +55
	DC (°C)	-40 ... +70	-40 ... +70	-40 ... +70
Cover protection category		IP40	IP40	IP40
Shock resistance	(G)	10	10	10
Vibration resistance	(G)	5	5	5
		(for 10..150Hz)	(for 10..150Hz)	(for 10..150Hz)

Table 1. Coil data DC version

Rated voltage V DC	Coil resistance Ω	Coil operating range V DC	
		Min. (at 20°C)	Max. (at 55°C)
12	160	9.6	13.2
24	640	19.2	26.4
48	2600	38.4	52.8
110	13600	88	121
220	54000	176	242

Table 2. Coil data AC 50/60Hz version

Rated voltage V AC	Coil resistance Ω	Coil operating range V AC	
		Min. (at 20°C)	Max. (at 55°C)
12	39	9.6	13.2
24	158	19.2	26.4
48	640	38.4	52.8
132	3770	96	120
230	16100	184	253



Miniature 2 pole plug-in relays

Electrical life at AC resistive load

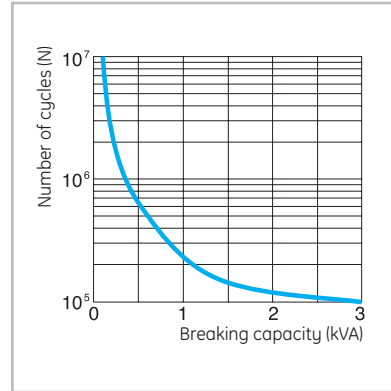

Electrical life reduction factor at AC inductive load

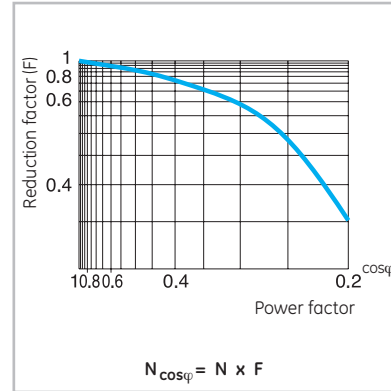

Max. DC resistive load breaking capacity

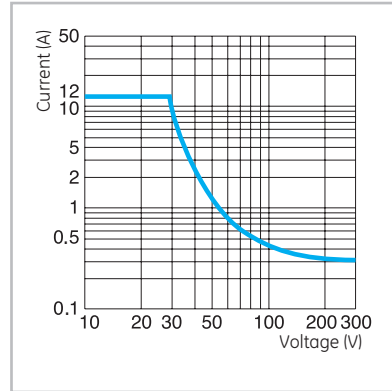

Miniature 3 pole plug-in relays

Electrical life at AC resistive load

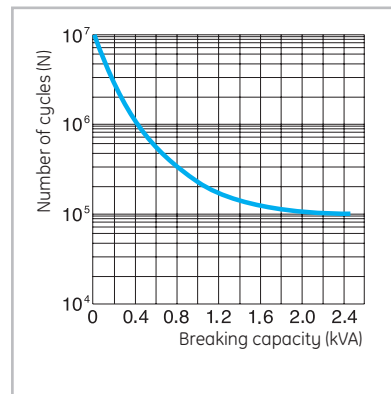

Electrical life reduction factor at AC inductive load

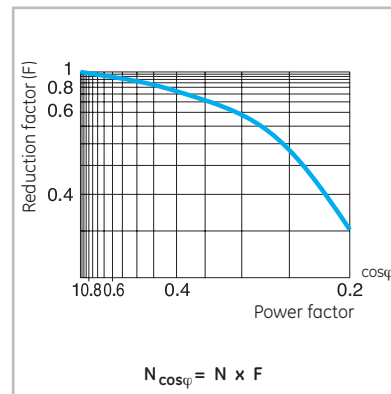

Max. DC load breaking capacity

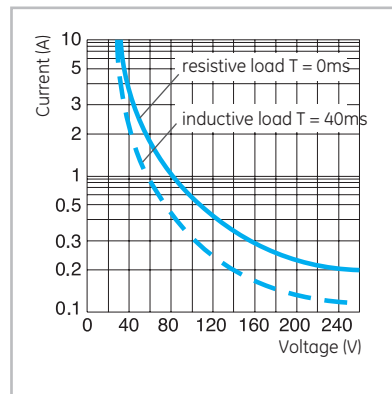

Miniature 4 pole plug-in relays

Electrical life at AC resistive load

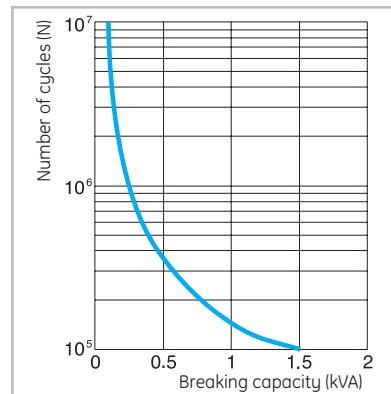

Electrical life reduction factor at AC inductive load

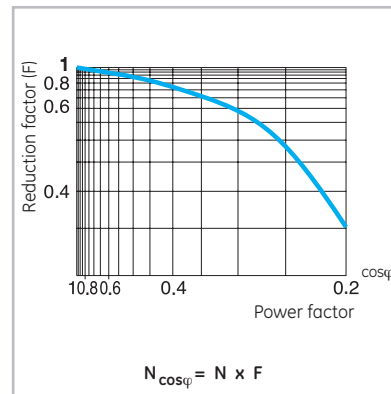

Max. DC resistive load breaking capacity

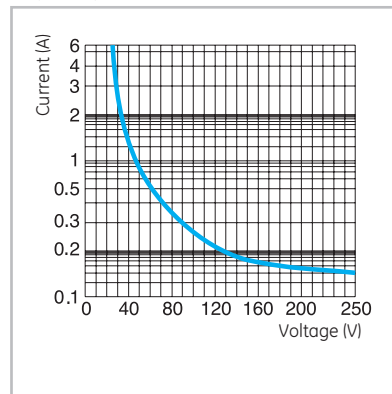

Technical data

Intro

A

**B**

C

D

E

F

G

H

I

J/X



Standard 8-11 pin plug-in relays

		PRC2P20...	PRC3P30...	
		Standard 8-pin	Standard 11-pin	
<b>Contacts</b>				
Number of contacts		2 changeover	3 changeover	
Standard material		AgNi	AgNi	
Optional material		AgNi/Au 5μ	AgNi/Au 5μ	
<b>Voltage</b>				
Max switching voltage	AC/DC (poll. 3)	250V	250V	
	AC (poll. 2)	400V	400V	
Min switching voltage AC/DC		10V (AgNi) 5V (AgNi/Au 5μ)	10V (AgNi) 5V (AgNi/Au 5μ)	
<b>Current</b>				
Rated load	AC1 (A)	10 (250V AC)	10 (250V AC)	
	AC15 (A)	4 (250V AC)	4 (250V AC)	
	DC1 (A)	10 (24V DC)	10 (24V DC)	
Min. switching current (mA)		5	5	
Max. inrush current (A)		30	30	
Rated current (A)		10	10	
Max. breaking capacity (VA)		2500	2500	
Resistance (mΩ)		H100 (100mA, 24V)	H100 (100mA, 24V)	
<b>Max. operating frequency</b>				
At rated load (cycles/hour)		1200	1200	
No load (cycles/hour)		12000	12000	
<b>Coil</b>				
Rated voltage	AC 50/60Hz (V)	6 ... 240	6 ... 240	
	DC (V)	6 ... 220	6 ... 220	
Must release time voltage	AC	≥0.15 Un	≥0.15 Un	
	DC	≥0.1 Un	≥0.1 Un	
Operating range of supply voltage		Table 1, 2	Table 1, 2	
Rated power consumption	AC 50Hz (VA)	2,7	2,7	
	60Hz (VA)	2,5	2,5	
	DC (W)	1,5	1,5	
	AC/DC (W)	-	-	
<b>Insulation</b>				
Insulation category		C250	C250	
Insulation rated voltage (VAC)		250	250	
Dielectric strength	Coil-Contact (VAC)	2500	2500	
	Contact-Contact (VAC)	1500	1500	
	Pole-Pole (VAC)	2000	2000	
Distance	Clearance (mm)	≥ 3	≥ 3	
	Creepage (mm)	≥ 4.2	≥ 4.2	
<b>General</b>				
Operating time (typical value)	AC (ms)	12	12	
	DC (ms)	12	12	
Release time (typical value)	AC (ms)	10	10	
	DC (ms)	7	7	
Electrical life	Resistive	≥ 2x10 <sup>5</sup> (10A, 250V AC)	≥ 2x10 <sup>5</sup> (10A, 250V AC)	
	CoS φ	See curves	See curves	
Mechanical life (cycles)		≥ 2x10 <sup>7</sup>	≥ 2x10 <sup>7</sup>	
Ambient temperature	Storage (°C)	-40 ... +85	-40 ... +85	
	Operating	AC (°C)	-40 ... +55	-40 ... +55
		DC (°C)	-40 ... +70	-40 ... +70
Cover protection category		IP40	IP40	
Shock resistance (G)		10	10	
Vibration resistance (G)		5	5	

Table 1. Coil data DC version

Rated voltage V DC	Coil resistance Ω	Coil operating range V DC	
		Min. (at 20°C)	Max. (at 55°C)
12	110	9.6	13.2
24	430	19.2	26.4
48	1750	38.4	52.8
110	9200	88	121
220	37000	176	242

Table 2. Coil data AC 50/60Hz version

Rated voltage V AC	Coil resistance Ω	Coil operating range V AC	
		Min. (at 20°C)	Max. (at 55°C)
12	18.5	9.6	13.2
24	75	19.2	26.4
48	305	38.4	52.8
120	1910	96	132
230	7080	184	253

Electrical life at AC resistive load

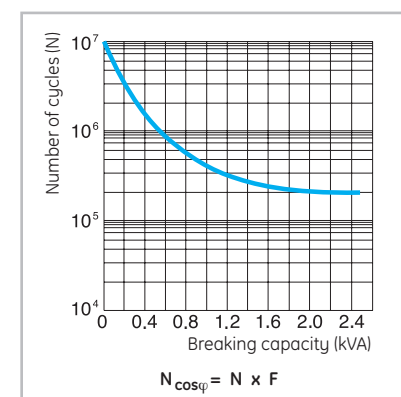

Electrical life reduction factor at AC inductive load

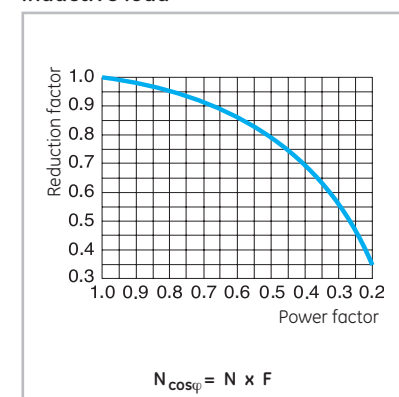

Max. DC load breaking capacity

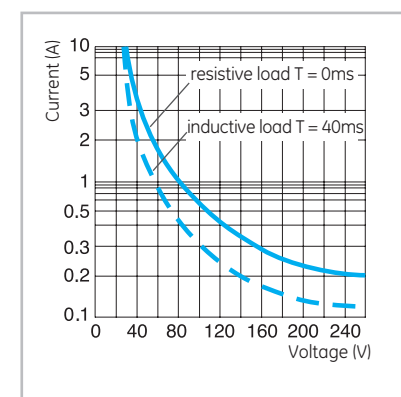

Interface plug-in relays

PRC1S13...

<b>Contacts</b>			
Number of contacts	1 changeover		
Standard material	AgSnO <sub>2</sub>		
Optional material			
<b>Voltage</b>			
Max switching voltage	AC/DC (poll. 3)	AC 250V / DC 150V	
	AC (poll. 2)	AC 400V / DC 300V	
Min switching voltage AC/DC	12V		
<b>Current</b>			
Rated load	AC1	(A) 6 (250V AC)	
	AC15	(A)	
	DC1	(A) 6 (24V DC)	
Min. switching current	(mA)	10	
Max. inrush current(A)	15		
Rated current	(A)	6	
Max. breaking capacity	(VA)	1500V	
Resistance	(mΩ)	≤100 (100mA, 24V)	
<b>Max. operating frequency</b>			
At rated load	360 cycles/hour		
No load	72000 cycles/hour		
<b>Coil</b>			
Rated voltage	AC/DC	(V) 24, 230	
	AC 50/60Hz	(V) 230	
	DC	(V) 12, 24	
Must release time	AC	≥0,2 Un	
voltage	DC	≥0,1 Un	
Operating range of supply voltage	See Table 1		
Rated power	AC 50Hz	(VA) 0.6...1.9	
consumption	60Hz	(VA) -	
	DC	(W) 0.33	
	AC/DC	(W) 0.48 (at 24V), 1.8 (at 230V)	
<b>Insulation</b>			
Insulation category	C250		
Insulation rated voltage	(VAC)	400	
Dielectric strength	Coil-Contact	(VAC) 4000	
	Contact-Contact	(VAC) 1000	
	Pole-Pole	(VAC) -	
Distance	Clearance	mm ≥ 8	
	Creepage	mm ≥ 8	
<b>General</b>			
Operating time	AC	(ms) 8	
(typical value)	DC	(ms) 6	
Release time	AC	(ms) 15	
(typical value)	DC	(ms) 8	
Electrical life	Resistive		
	Cos φ		
Mechanical life (cycles)	20x10 <sup>6</sup>		
Ambient temperature	Storage	(°C) -40 ... +70	
	Operating	AC	(°C) -20 ... +55
		DC	(°C) -20 ... +55
Cover protection category	IP20		
Shock resistance	(G)	10	
Vibration resistance	(G)	0.062" DA	
		(10 ... 55Hz)	

Table 1. Interface relay

Rated voltage V		Coil operating range V DC	
		Min.	Max.
12	DC	9	17
24	DC	17	30
24	AC/DC	18	30
230	AC	80	250
230	AC/DC	185	250

Technical data

Intro

A

**B**

C

D

E

F

G

H

I

J/X



Interface relay for PLC systems

PRC1T10...		
<b>Contacts</b>		
Number of contacts		1 changeover
Standard material		AgNi
Optional material		
<b>Voltage</b>		
Max. switching voltage	AC/DC	AC 400V / DC 300V
Min. switching voltage	AC/DC	5V
<b>Current</b>		
Rated load	AC1	(A) 16 (250V AC)
	DC1	(A) 16 (24V DC)
Min. switching current	(mA)	5
Max. inrush current	(A)	30
Rated current	(A)	16
Max. breaking capacity	(VA)	4000
Min. breaking capacity	(W)	0,3
Resistance	(mΩ)	≤100 (at 1A, 24V)
<b>Max. operating frequency</b>		
At rated load		600 cycles/hour
No load		72000 cycles/hour
<b>Coil</b>		
Rated voltage	AC 50/60Hz	(V) 24,120, 230
	DC	(V) 12, 24, 110
Must release time	AC	≥0.15 Un
voltage	DC	≥0.1 Un
Operating range of supply voltage		See Table 1, 2
Rated power	AC	(VA) 0.75
consumption	DC	(W) 0.4
<b>Insulation</b>		
Insulation category		C250
Insulation rated voltage	(VAC)	400
Dielectric strength	Coil-Contact	(VAC) 5000
	Contact-Contact	(VAC) 1000
	Pole-Pole	(VAC) -
Distance	Clearance	mm ≥ 10
	Creepage	mm ≥ 10
<b>contact coil</b>		
<b>General</b>		
Operating time	AC	(ms) 7
(typical value)	DC	(ms) 7
Release time	AC	(ms) 5
(typical value)	DC	(ms) 3
Electrical life	Resistive	(s) ≥ 0.7 × 10 <sup>5</sup> (at 16A, 250VAC)
	Cos φ	See curves
	L/R = 40ms	≥ 10 <sup>5</sup> (at 0.12A, 220VDC)
Mechanical life (cycles)		3x10 <sup>7</sup>
Ambient temperature	Storage	(°C) -40 ... +70
	Operating	(°C) -40 ... +70
Cover protection category		IP40
Shock resistance	(G)	30
Vibration resistance	(G)	10 (for 10 ... 150Hz)

Table 1. Coil data DC version

Rated voltage V DC	Coil resistance Ω (±10%) at 20°C	Coil operating range V DC	
		U Min.	U Max.
12	360	8.4	30.6
24	1440	16.8	61.2
110/25/200	77	280	

Table 2. Coil data AC 50/60Hz version

Rated voltage V AC	Coil resistance Ω (±10%) at 20°C	Coil operating range V AC	
		U Min.	U Max.
24	400	19.2	28.8
120	10200	96	144
230	38500	184	276

Electrical life at AC resistive load

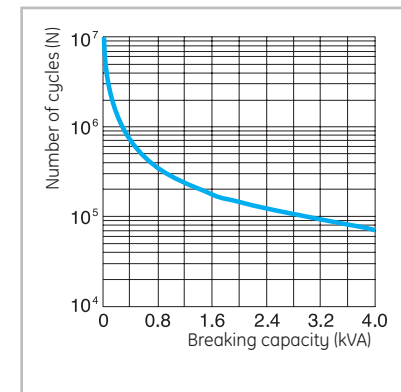

Electrical life reduction factor at AC inductive load

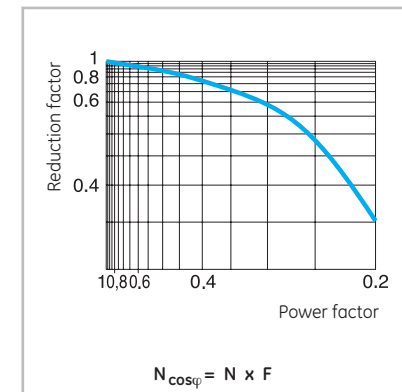

Max. DC load breaking capacity

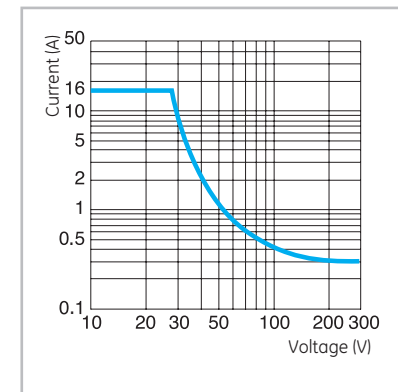

Interface relay for PLC systems

PRC1T20...

<b>Contacts</b>		
Number of contacts		2 changeover
Standard material		AgNi
Optional material		
<b>Voltage</b>		
Max. switching voltage	AC/DC	AC 400V / DC 300V
Min. switching voltage	AC/DC	5V
<b>Current</b>		
Rated load	AC1	(A) 8 (250V AC)
	DC1	(A) 8 (24V DC)
Min. switching current	(mA)	5
Max. inrush current	(A)	15
Rated current	(A)	8
Max. breaking capacity	(VA)	2000
Min. breaking capacity	(W)	0,3
Resistance	(mΩ)	≤100 (at 1A, 24V)
<b>Max. operating frequency</b>		
At rated load		600 cycles/hour
No load		72000 cycles/hour
<b>Coil</b>		
Rated voltage	AC 50/60Hz	(V) 24, 230
	DC	(V) 12, 24
Must release time	AC	≥0.15 Un
voltage	DC	≥0.1 Un
Operating range of supply voltage		See Table 1, 2
Rated power	AC	(VA) 0.75
consumption	DC	(W) 0.4
<b>Insulation</b>		
Insulation category		C250
Insulation rated voltage	(VAC)	400
Dielectric strength	Coil-Contact	(VAC) 5000
	Contact-Contact	(VAC) 1000
	Pole-Pole	(VAC) -
Distance	Clearance	mm ≥ 10
	contact coil	Creepage
<b>General</b>		
Operating time	AC	(ms) 7
(typical value)	DC	(ms) 7
Release time	AC	(ms) 5
(typical value)	DC	(ms) 3
Electrical life	Resistive	(s) ≥ 0.7 x 10 <sup>5</sup> (at 8A, 250VAC)
	Cos φ	See curves
	L/R = 40ms	≥ 10 <sup>5</sup> (at 0,12A, 220VDC)
Mechanical life (cycles)		3x10 <sup>7</sup>
Ambient temperature	Storage	(°C) -40 ... +70
	Operating	(°C) -40 ... +70
Cover protection category		IP40
Shock resistance	(G)	20
Vibration resistance	(G)	10 (for 10 ... 150Hz)

Table 1. Coil data DC version

Rated voltage V DC	Coil resistance (±10%) at 20°C Ω	Coil operating range V DC	
		U Min.	U Max.
12	360	8.4	30.6
24	1440	16.8	61.2
110	25200	77	280

Table 2. Coil data AC 50/60 Hz version

Rated voltage V AC	Coil resistance (±10%) at 20°C Ω	Coil operating range V AC	
		U Min.	U Max.
24	400	19.2	28.8
120	10200	96	144
230	38500	184	276

Technical data

Intro

A

**B**

C

D

E

F

G

H

I

J/X

Electrical life at AC resistive load

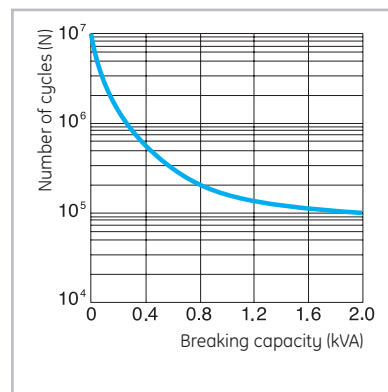

Electrical life reduction factor at AC inductive load

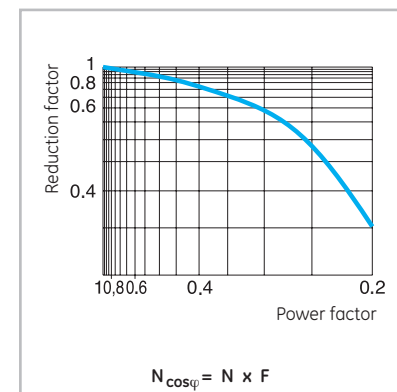

Max. DC load breaking capacity

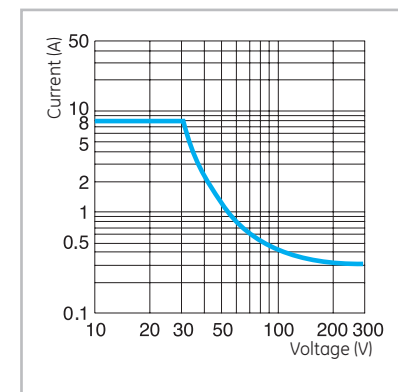

Dimensional drawings

Miniature

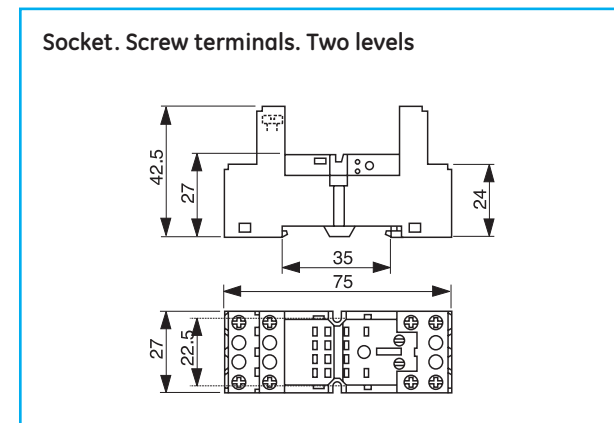
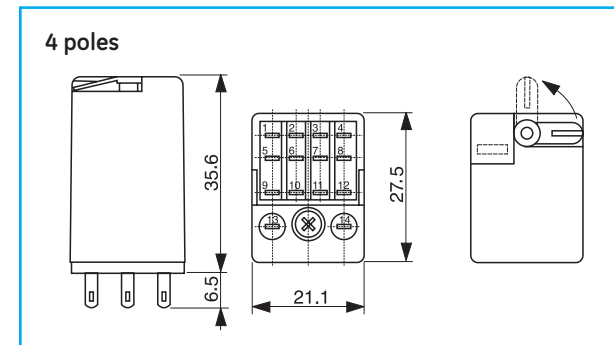
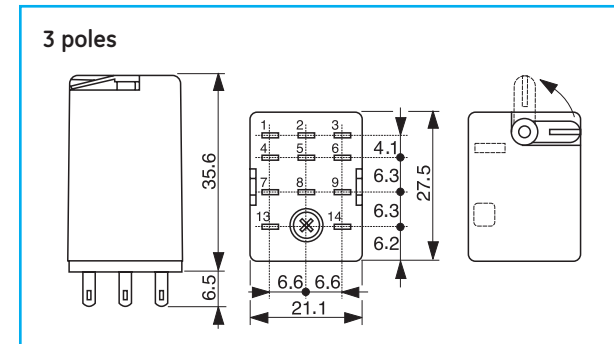
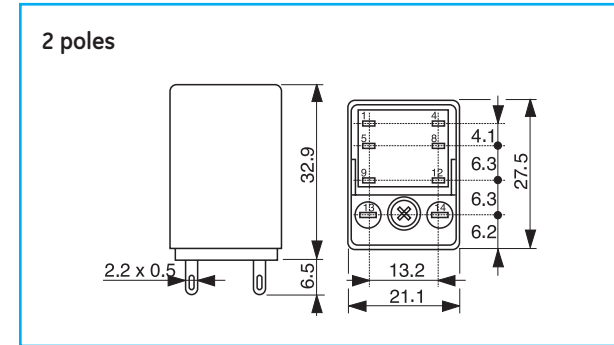

Standard 8-11 pin

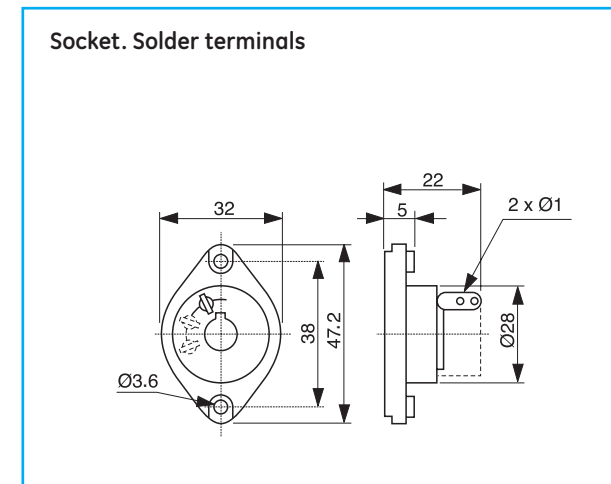
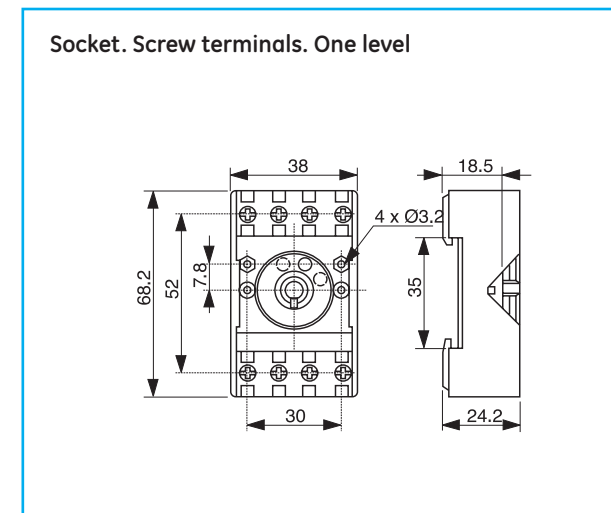
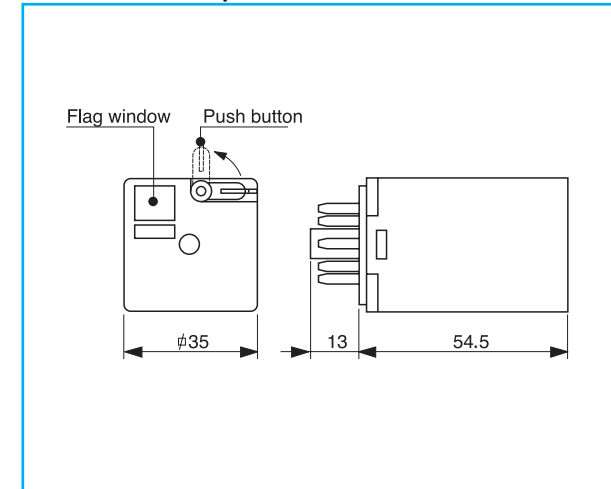





Interface relay

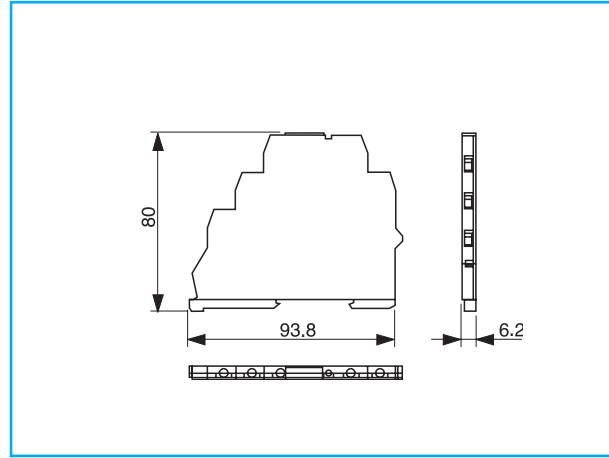

Socket for miniature P.C.B. relays

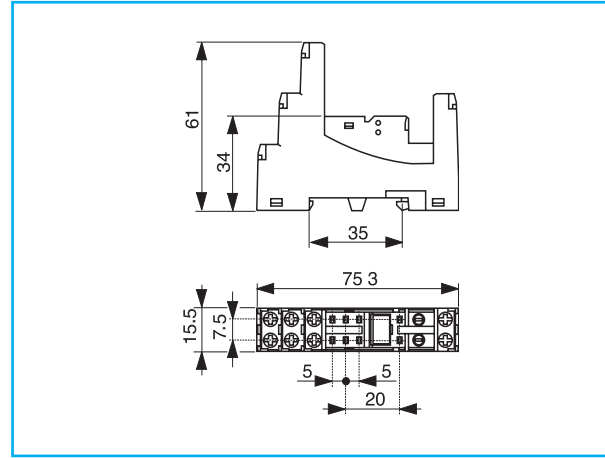

Dimensions

Intro

A

**B**

C

D

E

F

G

H

I

J/X



Technical data

General

Maximum number of contacts (MCR...)	4
Rated thermal current (I <sub>th</sub> ) θ ≤ 60°	16A
Rated operational voltage (U <sub>e</sub> ) acc. IEC 60947.1	690V
Insulation voltage (U <sub>i</sub> ) acc. IEC 60947.1	750V

Conformity to standards

IEC / EN 60947-5-1	IEC / EN 60947-1	BS 4794
EN 50002	EN 50005	EN 50011
NFC 63-110	NFC 63-140	CENELEC HD 420
CSA C22.2/14	VDE 0660	UL 508

Approvals

cULus	DEMKO	NEMKO
SEMKO	SETI	RINA
Lloyd's Register	Bureau Veritas	CE

Ambient conditions

Storage temperature	-55°C to +80°C	
Operation temperature	-40°C to +60°C	
Altitude	up to 3000m	Nominal values
	from 3000 to 4000m	90%I <sub>e</sub> 80%U <sub>e</sub>
	from 4000 to 5000m	80%I <sub>e</sub> 75%U <sub>e</sub>

Climatic resistance (IEC 68-2)

Continuous tests		40 / 125 / 56
Cold (72h)	Temperature	-40°C
	Dry heat (96h)	
	Temperature	+125°C
	Relative humidity	< 50%
Humid heat (56 days)	Temperature	+40°C
	Relative humidity	95%
Cyclical tests (6 cycles)		
Humid heat		
First half-cycle (12h)	Low temperature	+25°C
	Relative humidity	93%
Second half-cycle (12h)	Low temperature	+55°C
	Relative humidity	95%

Shock resistance (IEC 68-2-27)

Continuously closed (at 0.8Us)	
Admissible acceleration	25 g
Impulse duration	11 ms
Continuously opened (no voltage)	
Admissible acceleration	20 g
Impulse duration	11 ms

Vibration resistance (IEC 68-2-6)

Continuously closed (at 0.8Us)	
Admissible acceleration	15 g
Sweep between	10 - 200 Hz
Continuously opened (no voltage)	
Admissible acceleration	5 g AC - 3.5 g DC
Sweep between	10 - 200 Hz

Mounting positions

With the same pick-up and drop-out voltage  
With the same rated power

-7% of connection voltage  
+4% of disconnection voltage  
With the same rated power

-7% of connection voltage  
+4% of disconnection voltage  
With the same rated power

Terminal capacity

Terminal with screw M3.5 Tightening torque		
(with pozidrive head and safety flange)		0.8 Nm - 7 Lb-in
Solid wire	mm <sup>2</sup>	0.75 to 2x2 w.
Flexible wire without terminal	mm <sup>2</sup>	0.75 to 2.5x2 w.
Flexible wire with terminal with cap	mm <sup>2</sup>	0.75 to 2.5x1 w.
	mm <sup>2</sup>	0.75 to 1x2 w.

Ring terminal cap	0.8 Nm - 7 Lb/in
-------------------	------------------

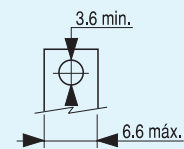

Fast-on 2.8 - 2 insulated terminals	mm <sup>2</sup>	1 x 2 w.
Terminal for printed circuit (Ø of PCB hole)		1.8mm
Ring terminal cap		7.8mm
Fork terminal cap		6.5mm





**Control circuit**

		MCRA...	MCR...C...	MCR...C...	MCR...I...	MCR...K...
Rated insulation voltage (Ui)	(V)	750	750	750	750	750
Standard voltages (Us)						
50Hz	(V)	24..690	-	-	-	-
60Hz	(V)	6..600	-	-	-	-
DC	(V)	-	6..440	12..440	24	24
Voltage <sup>[1]</sup>						
Operating limits	xUs	0.8..1.1	0.8..1.1	0.7..1.3	0.8..1.25	0.7..1.25
Drop-out	xUs	0.35..0.55	0.15..0.3	0.15..0.3	0.15..0.3	0.13..0.35
Consumption						
Pick-up	(VA)	26	-	-	-	-
Seal	(VA)	4	-	-	-	-
DC	(W)	-	3	4	1.2	2
Power factor						
Pick-up	(cos φ)	0.8	-	-	-	-
Seal	(cos φ)	0.35	-	-	-	-
Power dissipation	(W)	1.4	3	4	1.2	2
Opening and closing times						
Values between ± %Us	%	+10...-20	+10...-20	+30...-30	+25...-20	+25...-20
Time at energisation NO	(ms)	6..13	22..36	17..28	30..70	20..50
Time at de-energisation NC	(ms)	8..16	9..12	9..12	9..16	9..16
Time at energisation NC	(ms)	5..11	18..27	12..25	20..45	18..35
Time at de-energisation NO	(ms)	6..13	5..7	5..7	5..9	5..9
Values at Us						
Time at energisation NO	(ms)	7..12	24..27	19..23	25..45	25..40
Time at de-energisation NC	(ms)	8..16	9..11	9..11	9..16	9..16
Time at energisation NC	(ms)	6..10	20..26	15..21	25..35	20..30
Time at de-energisation NO	(ms)	6..13	5..8	5..8	5..9	5..9
Maximum time without voltage (without effecting the closed magnetic circuit)	(ms)	3	3	3	3	3
Mechanical endurance						
Monofrequency	x10 <sup>6</sup> ops.	15	-	-	-	-
Dual-frequency	x10 <sup>6</sup> ops.	10	-	-	-	-
DC	x10 <sup>6</sup> ops.	-	10	10	10	10
Maximum rate (no load)						
Monofrequency	n° ops/h	9000	-	-	-	-
Dual-frequency	n° ops/h	3600	-	-	-	-
DC	n° ops/h	-	9000	9000	9000	9000

**Contact sequence (distance in mm)**

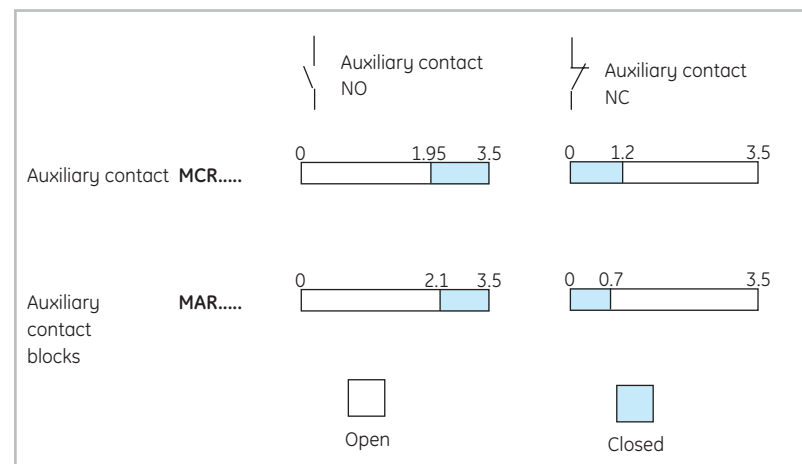

Technical data

Intro

A

**B**

C

D

E

F

G

H

I

J/X



Internal auxiliary contacts

		MCR.....
Rated insulation voltage (Ui) acc. IEC 60947-1		750V
Rated thermal current (Ith) $\theta \leq 60^\circ\text{C}$ (1)		16A
Making capacity (r.m.s.) acc. IEC 60947-5		
AC-15	$U_e \leq 440\text{V } 50/60 \text{ Hz}$	160A
DC-13	$U_e \leq 220\text{V DC}$	3A
Breaking capacity (r.m.s.) acc. IEC 60947-5		
AC-15	$U_e \leq 440\text{V } 50/60 \text{ Hz}$	106A
DC-13 (L/R = 100 ms)	$U_e \leq 220\text{V DC}$	1.2A
	$U_e = 110\text{V DC}$	3A
	$U_e = 48\text{V DC}$	10A
Rated voltage and rated current $U_e$ - $I_e$		
AC-15	according to IEC 947	110/120V - 6A
		220/240V - 6A
		380/400V - 4A
		415/440V - 4A
		500V - 2.5A
	according to UL, CSA	660/690V - 1.5A
DC-13	according to UL, CSA	A600
	according to IEC	24V - 5A
		48V - 3.5 A
		110V - 1.2A
		220V - 0.6A
		440V - 0.25A
	according to UL, CSA	P600
Minimum operational power (operational safety)		5 mA, 17V
Short-circuit protection (max.class gI fuse without welding)		10A
Insulation resistance		
	between contacts	> 10 m $\Omega$
	between contacts and earth	> 10 m $\Omega$
	between input and output	> 10 m $\Omega$
Guaranteed no overlap of the contacts		
	Space	1,1 mm
	minimum time	> 2 ms
Impedance		2.3 m $\Omega$
Terminal capacity		Same as main circuit

Tripping characteristics (AC)

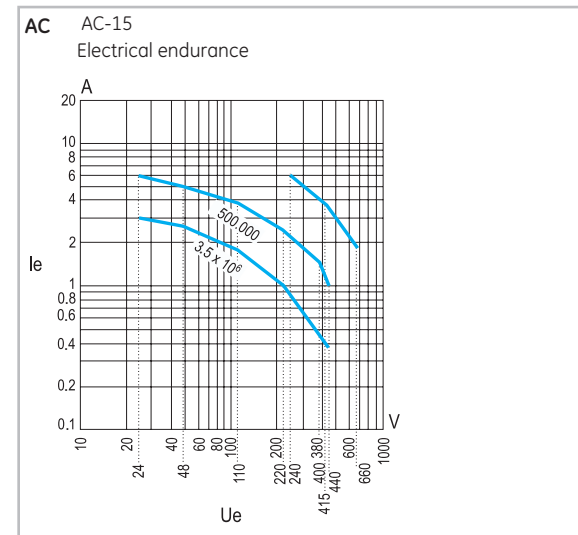

Tripping characteristics  $I_e/U_e$

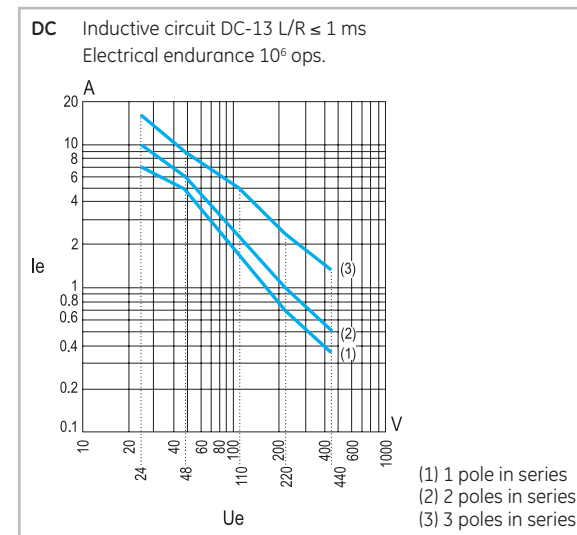
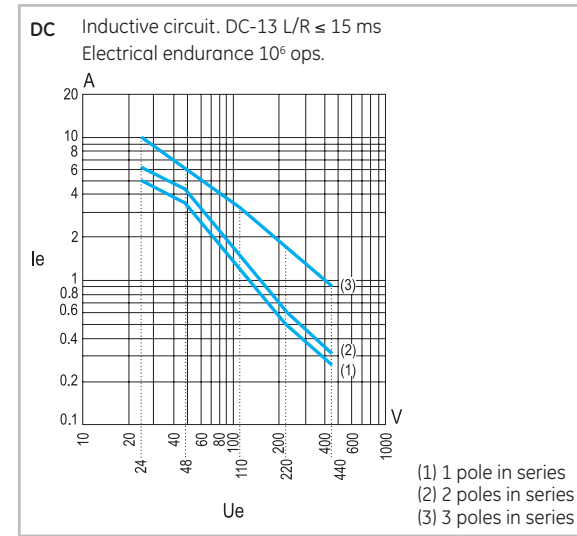
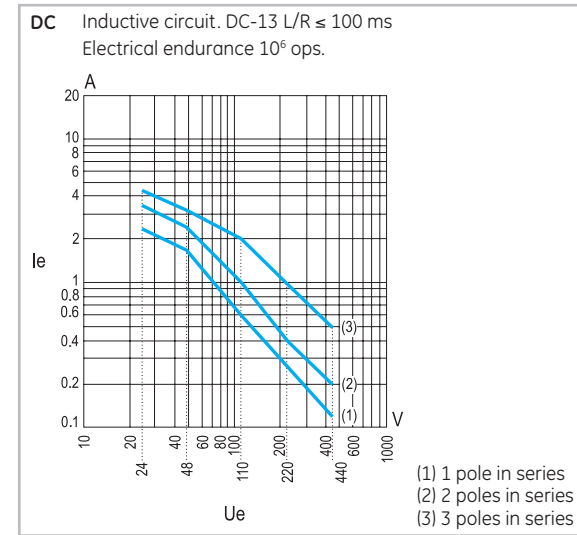

External auxiliary contact blocks

		MARN..., MARL...
Rated insulation voltage (U <sub>i</sub> ) acc. IEC 60947-1		750V
Rated thermal current (I <sub>th</sub> ) θ ≤ 60°C <sup>(1)</sup>		10A
Making capacity (r.m.s.) acc. IEC 60947-5		
AC-15	U <sub>e</sub> ≤ 220V 50/60 Hz	73A
	U <sub>e</sub> = 380V 50/60 Hz	38A
	U <sub>e</sub> = 690V 50/60 Hz	22A
DC-13 L/R = 100 ms	U <sub>e</sub> ≤ 100V DC	2.6A
	U <sub>e</sub> = 220V DC	1A
	U <sub>e</sub> = 440V DC	0.6A
Breaking capacity (r.m.s.) acc. IEC 60947-5		
AC-15	U <sub>e</sub> ≤ 220V 50/60 Hz	73A
	U <sub>e</sub> = 380V 50/60 Hz	38A
	U <sub>e</sub> = 690V 50/60 Hz	22A
DC-13 L/R = 100 ms	U <sub>e</sub> ≤ 100V DC	2A
	U <sub>e</sub> = 220V DC	0.8A
	U <sub>e</sub> = 440V DC	0.4A
Rated voltage and rated current U <sub>e</sub> -I <sub>e</sub>		
AC-15	according to IEC 60947	110/120V - 6A
		220/240V - 6A
		380/400V - 3A
		415/440V - 3A
		500V - 1A
		660/680V - 1A
	according to UL, CSA	A600
DC-13	according to IEC 60947	24V - 4A
		48V - 2A
		110V - 0.7A
		220V - 0.3A
		440V - 0.1A
Minimum operational power (operational safety)		5 mA, 17V
Short-circuit protection (max.class gI fuse without welding)		10A
Insulation resistance		
	between contacts	> 10 mΩ
	between contacts and earth	> 10 mΩ
	between input and output	> 10 mΩ
Guaranteed no overlap of the contacts		
	Space	0.5 mm
	minimum time	> 2 ms
Impedance		2.4 mΩ
Terminal capacity		Same as main circuit

Tripping characteristics (AC)

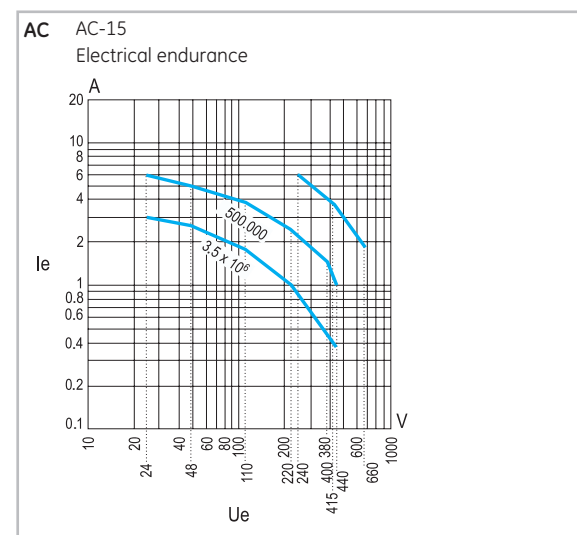

Tripping characteristics I<sub>e</sub>/U<sub>e</sub>

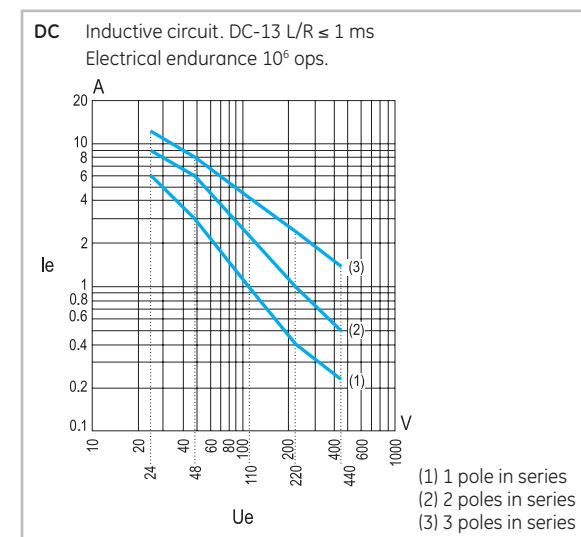
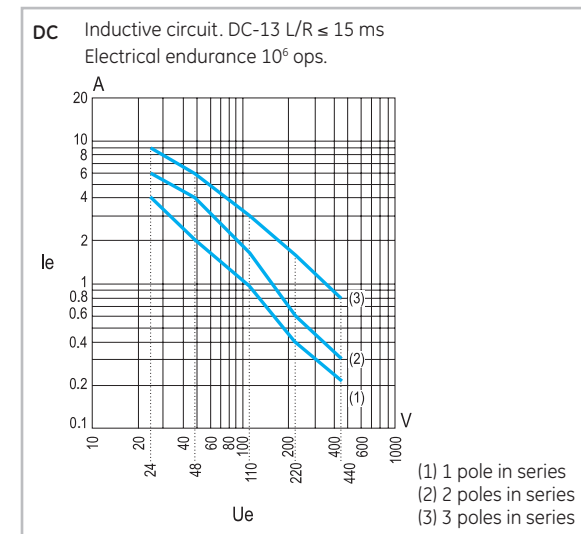
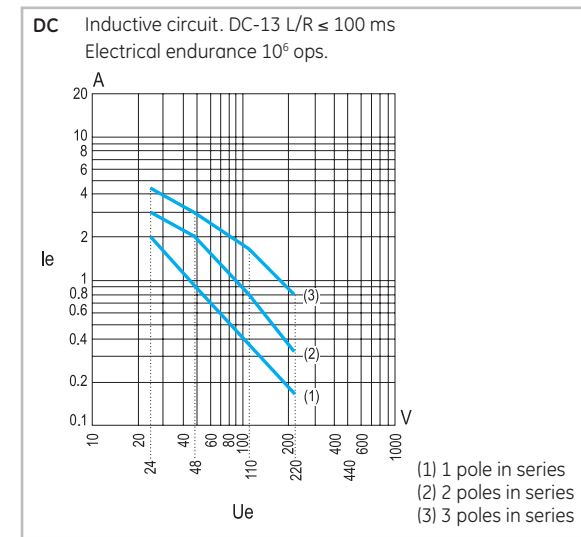

Technical data

Intro

A

**B**

C

D

E

F

G

H

I

J/X



**Electronic timer block**

		MREBC...
Rated insulation voltage (Ui)		750V
Rated thermal current (Ith) $\theta \leq 60^\circ\text{C}$ <sup>(1)</sup>		0.55V
Standard voltages (AC y DC)		24 to 250V
Operation limits		0.80 to 1.1 Us (0.85 to 1.1 Us at 12V)
Voltage drop		< 3V
Maximum load current at		
	20°C	0.9A
	40°C	0.72A
	60°C	0.55A
Minimum load for safe operation		> 10 mA
Maximum current (peak)		10A for 40 ms
Leakage current at 220V		< 5 mA
Operational current		
	AC-15	0.7A
	DC-13	0.9A
Timing range (delay ON)		0.5 to 60 s ( $\pm$ 6 s)
Rearrangement time		< 100 ms
Repeatability (accuracy)		$\pm$ 1 %
Ambient temperature		
	Storage	from -55 up to + 80°C
	Operation	from -5 up to + 60°C
Degree of protection		IP20
Mounting position		any
Terminals : 2 free cables		1 mm <sup>2</sup> (AWG 17) 250 mm

MREBC\_0AC2

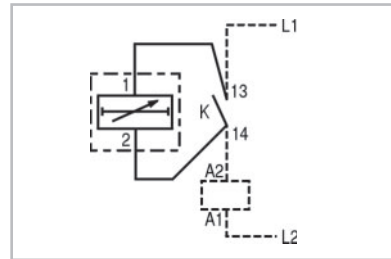

Terminal numbering

Auxiliary contactors. According to EN 50011

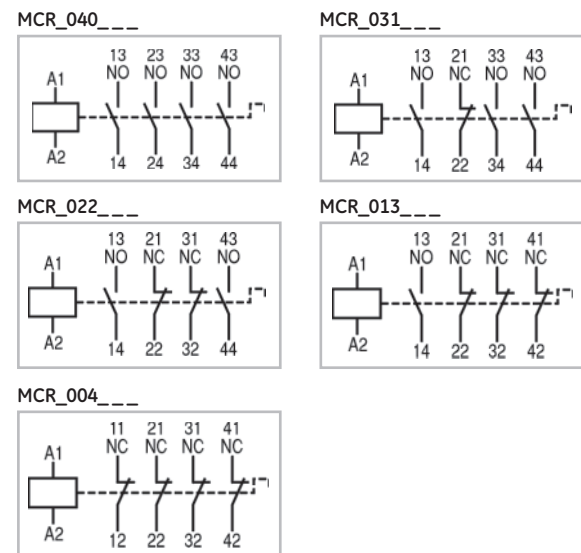

Auxiliary contact blocks

According to EN 50005 & EN 50011

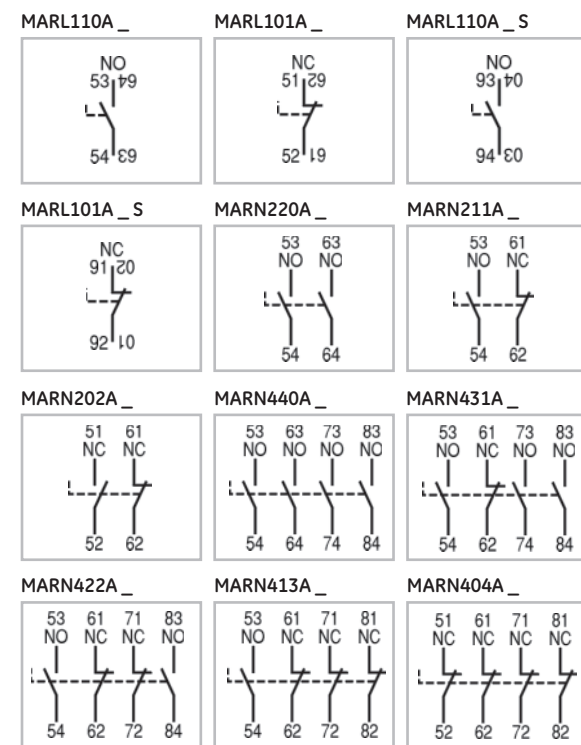

Transient voltage suppressor block

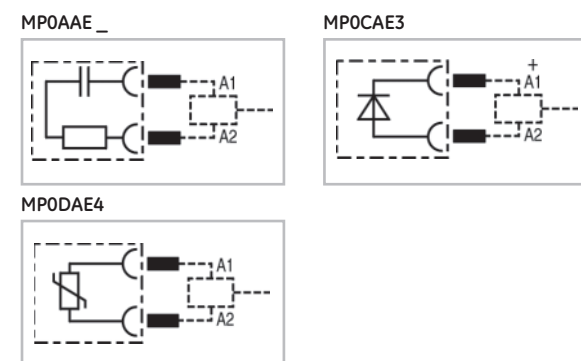

Technical data

Intro

A

B

C

D

E

F

G

H

I

J/X



**Terminal numbering in accordance with EN 50011**

By combining other basic auxiliary contactors with auxiliary contact blocks MAR..., it is possible to obtain other combinations, and positions of contacts which are not covered by the table. But in all cases the maximum number of auxiliary contacts should be ten.

**Type E**  
Standard contact combination in which the interchangeability of the devices does not affect the cabling or the diagram. Specifies a particular contact numbering and positioning.

	Final structure of the combination	Auxiliary contacts		Auxiliary contactor + Auxiliary contact blocks to be added	
		Combination Description	NO NC		
Type E		40E	4 0	MCRA040A..	
		31E	3 1	MCRA031A..	
		22E	2 2	MCRA022A..	
		13E	1 3	MCRA013A..	
		04E	0 4	MCRA004A..	
			60E	6 0	MCRA040A.. + MARN220A..
			51E	5 1	MCRA040A.. + MARN211A..
			42E	4 2	MCRA040A.. + MARN202A..
			80E	8 0	MCRA040A.. + MARN440A..
			71E	7 1	MCRA040A.. + MARN431A..
			62E	6 2	MCRA040A.. + MARN422A..
			53E	5 3	MCRA040A.. + MARN413A..
			44E	4 4	MCRA040A.. + MARN404A..
			50E	5 0	MCRA040A.. + MARL110A..
			41E	4 1	MCRA031A.. + MARL110A..
			32E	3 2	MCRA022A.. + MARL110A..
		23E	2 3	MCRA013A.. + MARL110A..	
		14E	1 4	MCRA013A.. + MARL101A..	
		05E	0 5	MCRA004A.. + MARL101A..	

Auxiliary minicontactors

Intro

A

B

C

D

E

F

G

H

I

J/X





**Terminal numbering in accordance with EN 50011 (continued)**

By combining other basic auxiliary contactors with auxiliary contact blocks MAR..., it is possible to obtain other combinations, and positions of contacts which are not covered by the table. But in all cases the maximum number of auxiliary contacts should be ten.

**Type Z**  
Contact combination the same as Type E. Interchangeability of the devices may affect the cabling and the diagram. Neither contact numbering nor positioning are retained.

**Type X**  
Contact combination the same as Type E. Interchangeability of the devices may affect the cabling but not the diagram. The contact numbering is maintained but not their position.

**Type Y**  
Contact combination which differs from Type E, although it is obtained by a combination of devices provided for this Type E.

	Final structure of the combination	Auxiliary contacts		Auxiliary contactor + Auxiliary contact blocks to be added
		Combination	Description	
Type Z			6 0	MCRA040A.. + MARL110A.. + MARL110A..
			5 1	MCRA040A.. + MARL110A.. + MARL101A..
			4 2	MCRA040A.. + MARL101A.. + MARL101A..
			10 0	MCRA040A.. + MARN440A.. + MARL110A..S + MARL110A..S
			5 5	MCRA040A.. + MARN413A.. + MARL101A..S + MARL101A..S
	Type X			8 0
			7 1	MCRA040A.. + MARL110A.. + MARL101A.. + MARL110A..S + MARL110A..S
			6 2	MCRA040A.. + MARL110A.. + MARL101A.. + MARL101A..S + MARL110A..S
			5 3	MCRA040A.. + MARL110A.. + MARL101A.. + MARL101A..S + MARL101A..S
			4 4	MCRA040A.. + MARL101A.. + MARL101A.. + MARL101A..S + MARL101A..S
			9 1	MCRA040A.. + MARN431A.. + MARL110A..S + MARL110A..S
			8 2	MCRA040A.. + MARN431A.. + MARL101A..S + MARL110A..S
			7 3	MCRA040A.. + MARN422A.. + MARL101A..S + MARL110A..S
			6 4	MCRA040A.. + MARN422A.. + MARL101A..S + MARL101A..S
Type Y				4 2
			3 3	MCRA022A.. + MARL110A.. + MARL101A..
			4 2	MCRA031A.. + MARN211A..
			3 3	MCRA022A.. + MARN211A..
			5 3	MCRA031A.. + MARN422A..
			4 4	MCRA022A.. + MARN422A..

Technical data

Intro

A

B

C

D

E

F

G

H

I

J/X



Dimensional drawings

Auxiliary minicontactors

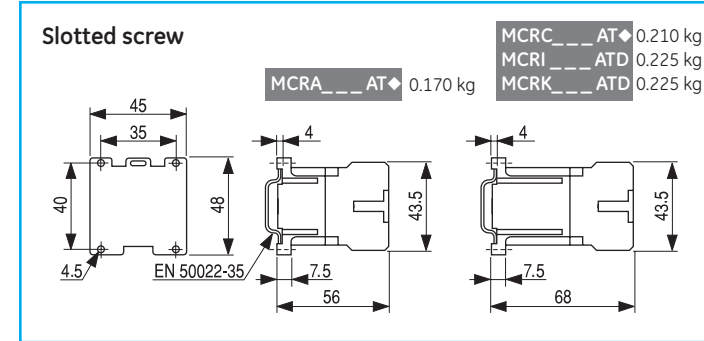

Auxiliary contact blocks. Front mounting

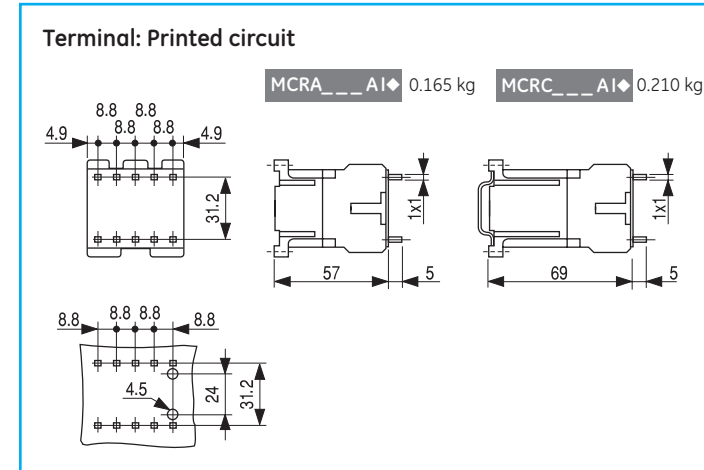
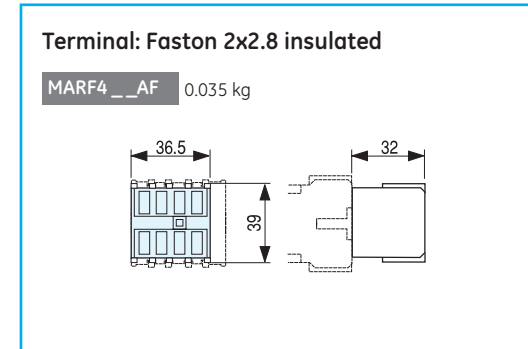
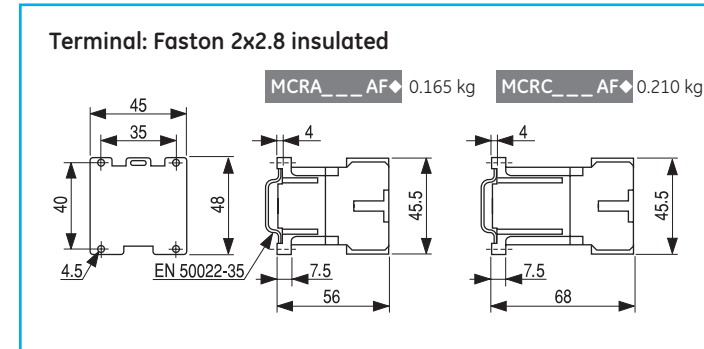
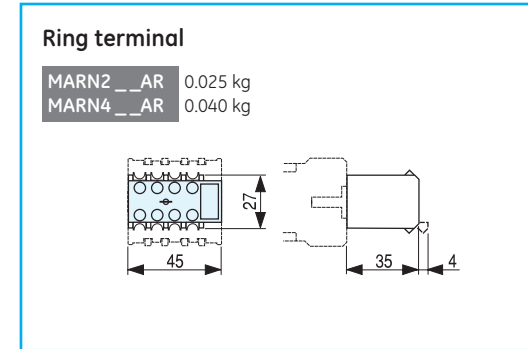
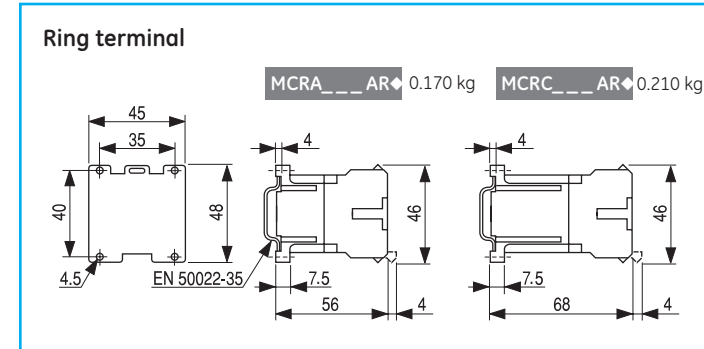
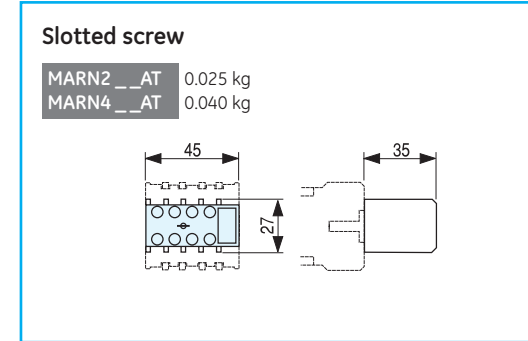

Auxiliary minicontactors

Intro

A

B

C

D

E

F

G

H

I

J/X



**Auxiliary contact blocks. Lateral mounting**

**Slotted screw**  
 MARL\_\_AT, ATS 0.013 kg

(1) AC-control.  
 (2) DC-control

**Electronic timer block**

MREBC\_OAC2 0.040 kg

(1) Frontal mounting  
 (2) Lateral mounting

**Ring terminal**

MARL\_\_AR, ARS 0.013 kg

(1) AC-control.  
 (2) DC-control

**Voltage suppressor block**

MPOA\_AE\_ 0.010 kg  
 MPOC\_AE3 0.010 kg

**Terminal: Faston 2x2.8 insulated**

MARL\_\_AF, AFS 0.009 kg

(1) AC-control.  
 (2) DC-control

**Terminal: Printed circuit**

MARL\_\_AI, AIS 0.009 kg

(1) AC-control  
 (2) DC-control

**Dimensions**

Intro
A
<b>B</b>
C
D
E
F
G
H
I
J/X



**General**

Maximum number of contacts	4
Rated thermal current (I <sub>th</sub> ) θ < 55°C	20A
Rated operational voltage (U <sub>e</sub> )	690V
Insulation voltage (U <sub>i</sub> )	1000V

**Conformity to standards**

IEC / EN 60947-1	IEC / EN 60947-5-1	ASE 1025
EN 50005	EN 50011	VDE 0660 / 102
NFC 63-110	NFC 63-140	
CENELEC HD 410	CENELEC HD 420	
NEMA ICS 1	CSA C22.2/14	
UL 508	BS 4794	

**Approvals**

cULus	DEMKO	NEMKO
SEMKO	FI	CE
Lloyd's Register	Bureau Veritas	

**Ambient conditions**

Storage temperature	-55°C to +80°C	
Operation temperature	-40°C to +60°C	
Altitude	up to 3000m	Nominal values
	from 3000 to 4000m	90%I <sub>e</sub> 80%U <sub>e</sub>
	from 4000 to 5000m	80%I <sub>e</sub> 75%U <sub>e</sub>

**Climatic resistance (IEC 68-2)**

Continuous tests		40 / 125 / 56
Cold (72h)	Temperature	-40°C
	Dry heat (96h)	
	Temperature	+125°C
	Relative humidity	< 50%
Humid heat (56 days)	Temperature	+40°C
	Relative humidity	95%
Cyclical tests (6 cycles)		
Humid heat	Temperature	+25°C
	Relative humidity	93%
First half-cycle (12h)	Low temperature	+25°C
	Relative humidity	93%
Second half-cycle (12h)	Low temperature	+55°C
	Relative humidity	95%

**Mounting positions**

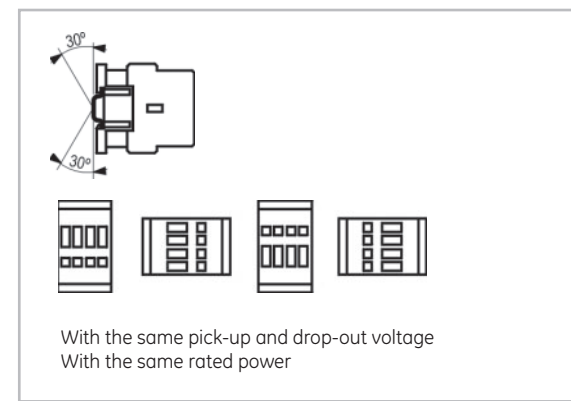

**Control circuit**

		RL4RA...	RL4RD...	RL4RD...W
Rated insulation voltage U <sub>i</sub>	(V)	1000	1000	1000
Standard voltages U <sub>s</sub>				
50Hz (V)		24 ... 690	-	-
60Hz (V)		24 ... 600	-	-
DC	(V)	-	12 ... 440	12 ... 440
Voltage <sup>(1)</sup>				
Operating limits	xU <sub>s</sub>	0.8 ... 1.1	0.8 ... 1.1	0.7 ... 1.3
Pick-up	xU <sub>s</sub>	0.65 ... 0.75	0.45 ... 0.65	0.45 ... 0.55
Seal	xU <sub>s</sub>	0.4 ... 0.55	0.15 ... 0.3	0.15 ... 0.3
Consumption				
AC	Magnetic circuit closed (VA)	6	-	-
	Magnetic circuit open (VA)	45	-	-
DC	Magnetic circuit closed (W)	-	5.5	6.5
	Magnetic circuit open (W)	-	5.5	6.5
Power dissipation	(W)	2.4	5.5	6.5
Power factor				
Magnetic circuit closed	cos φ	0.34	-	-
	cos φ	0.82	-	-
Opening and closing times				
at 0.8 to 1.1 U <sub>s</sub>				
Closing time NO	(ms)	6 ... 25	35 ... 65	25 ... 65
Opening time NO	(ms)	6 ... 13	6 ... 13	6 ... 13
at U <sub>s</sub>				
Closing time NO	(ms)	8 ... 20	35 ... 45	25 ... 55
Opening time NO	(ms)	6 ... 13	7 ... 12	6 ... 13
Mechanical endurance	10 <sup>6</sup> ops	15	15	15
Maximum rate no load	ops/h	9000	3600	3600

**Contact sequence (distance in mm)**

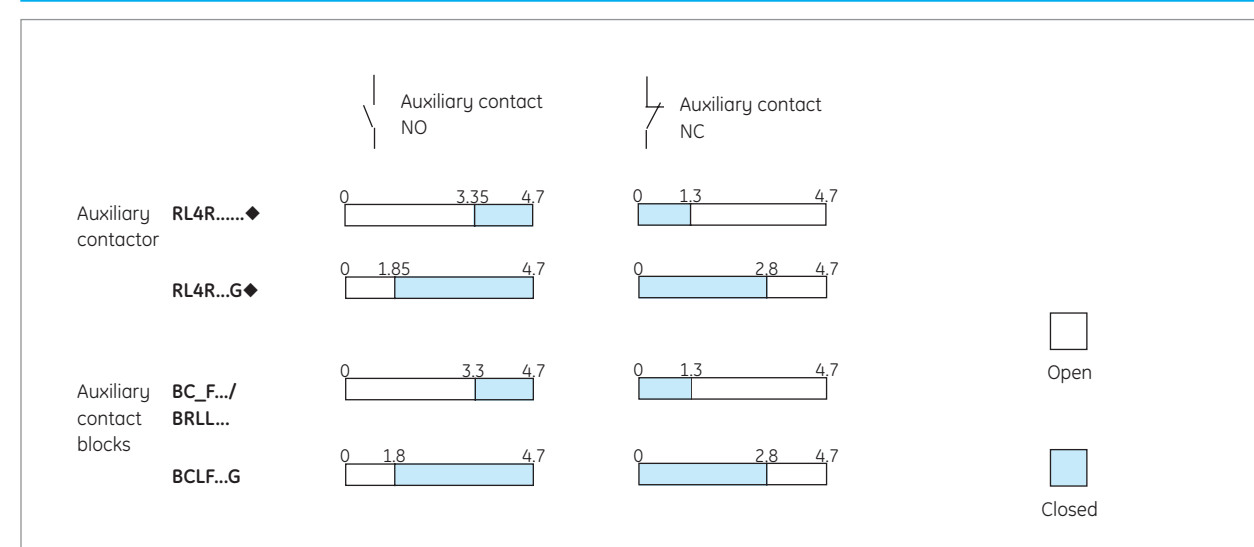

## Internal auxiliary contacts

		RL4.....
Rated insulation voltage (Ui) acc. IEC 60947-5		1000V
Rated thermal current (Ith) < 55°C		20A
Making capacity (r.m.s.) acc. IEC 60947-5		
AC-15	Ue ≤ 400V, 50/60 Hz	250A
DC-13	Ue ≤ 220V DC	250A
Breaking capacity (r.m.s.) acc. IEC 60947-5		
AC-15	Ue ≤ 400V, 50/60 Hz	250A
DC-13	Ue ≤ 220V DC	2A (4A with 2 contacts in series)
	Ue ≤ 110V DC	7A (12A with 2 contacts in series)
	Ue ≤ 48V DC	10A (18A with 2 contacts in series)
Rated voltage and rated current Ue-Ie		
AC-15	according to IEC	110/120V - 10A 220/240V - 10A 380/400V - 6A 415/440V - 5A 500V - 4A 660/690V - 2A
	according to UL, CSA	A600
DC-13	according to IEC	24V - 6A 48V - 4A 110V - 2A 220V - 0.7A 440V - 0.35A
	according to UL, CSA	P600
Electrical endurance		1 x 10 <sup>6</sup> ops.
Minimum operational voltage (operational safety)		17V
Minimum operational current		5mA
Short-circuit protection		
	max. fus. class gL fuse	20A
	without welding	10A
Insulation resistance		
	between contacts	> 10 mΩ
	between contacts and earth	> 10 mΩ
	between input and output	> 10 mΩ
Guaranteed no overlap between NO and NC contacts		
	space	1.3 mm
	minimum time	1.5 ms
Impedance		1.28 mΩ

## Terminal capacity

Solid, stranded and finely stranded without end sleeve	mm <sup>2</sup>	2 x 0.5 to 6
Finely stranded with end sleeve	mm <sup>2</sup>	2 x 1 to 6
AWG wires, solid and stranded	mm <sup>2</sup>	2 x 20 to 12
Tightening torque		1.1 Nm / 10 Lb.in
Ring terminals		1.6 Nm / 15 Lb.in

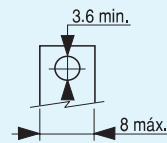

## Instantaneous auxiliary contact blocks

		BCLF./BCRF./BRLL..
Rated insulation voltage (Ui) acc. IEC 60947-5		1000V
Rated thermal current (Ith) θ < 55°C		10A
Making capacity (r.m.s.) acc. IEC 60947-5		
AC-15	Ue ≤ 440V, 50/60 Hz	90A
DC-13	Ue ≤ 220V DC	90A
Breaking capacity (r.m.s.) acc. IEC 60947-5		
AC-15	Ue ≤ 400V, 50/60 Hz	60A
DC-13	Ue ≤ 220V DC	0.95A
Rated voltage and rated current Ue-Ie		
AC-15	according to IEC	110/120V - 6A 220/240V - 6A 380/400V - 4A 415/440V - 3.5A 500V - 2.5A 660/690V - 1.5A
	according to UL, CSA	A600
DC-13		24V - 4A 48V - 2A 110V - 0.7A 220V - 0.3A 415/440V - 0.15A
	according to UL, CSA	Q600
Electrical endurance		1 x 10 <sup>6</sup> ops.
Minimum operational voltage (operational safety)		17V
Minimum operational current		5mA
Short-circuit protection (without welding) gL		10A
Insulation resistance		
	between contacts	> 10 mΩ
	between contacts and earth	> 10 mΩ
	between input and output	> 10 mΩ
Guaranteed no overlap between NO and NC contacts		
	Space	1.3 mm
	minimum time	1.5 ms
Impedance of the contacts		1.28 mΩ

## Terminal capacity

Solid, stranded and finely stranded without end sleeve	mm <sup>2</sup>	2 x 0.5 to 2.5
Finely stranded with end sleeve	mm <sup>2</sup>	2 x 2.5 to 4
AWG wires, solid and stranded	mm <sup>2</sup>	2 x 20 to 10
Tightening torque		0.8 Nm / 7 Lb.in
Ring terminals		0.8 Nm / 7 Lb.in

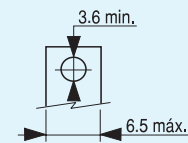

## Technical data

Intro

A

B

C

D

E

F

G

H

I

J/X



**Timed auxiliary contact blocks**

	BTLF... / BTRF...
Rated insulation voltage (Ui) acc. IEC 60947-5	1000V
Rated thermal current (Ith) @ < 55°C	10A
Making capacity (r.m.s.) acc. IEC 60947-5	
AC-15      Ue ≤ 440V, 50/60 Hz	90A
DC-13      Ue ≤ 220V DC	90A
Breaking capacity (r.m.s.) acc. IEC 60947-5	
AC-15      Ue ≤ 400V, 50/60 Hz	60A
DC-13      Ue ≤ 220V DC	0.95A
Rated voltage and rated current Ue-Ie	
AC-15      according to IEC	110/120V - 6A 220/240V - 6A 380/400V - 4A 415/440V - 3.5A 500V - 2.5A 660/690V - 1.5A
DC-13      according to UL, CSA	A600
DC-13      according to IEC	24V - 4A 48V - 2A 110V - 0.7A 220V - 0.3A 415/440V - 0.15A
DC-13      according to UL, CSA	Q600
Electrical endurance	1 × 10 <sup>6</sup> ops.
Minimum operational voltage (operational safety)	17V
Minimum operational current	5mA
Short-circuit protection (without welding) gL	10A
Insulation resistance	
between contacts	> 10 MΩ
between contacts and earth	> 10 MΩ
between input and output	> 10 MΩ
Guaranteed no overlap between NO and NC contacts	
space	1.3 mm
minimum time	1.5 ms
Timing	
(Ambient temperature between - 25 and + 55°C)	
Accuracy	± 5 %
Loss of accuracy after 0.5 × 10 <sup>6</sup> ops.	+ 20 %
Loss of accuracy per rise °C (0 - 55°C)	+ 0.75 % per °C
Impedance of the contacts	1.28 mΩ
Mechanical endurance	5 × 10 <sup>6</sup> ops.
Peak current	
during 1 s.	50A
during 0.1 s.	100A

**Terminal capacity**

Solid, stranded and finely stranded without end sleeve	(mm <sup>2</sup> )	2 × 0.5 to 2.5 2 × 2.5 to 4
Finely stranded with end sleeve	(mm <sup>2</sup> )	2 × 0.5 to 2.5 2 × 2.5 to 4
AWG wires, solid and stranded	(mm <sup>2</sup> )	2 × 20 to 10
Tightening torque		0.8 Nm / 7 Lb.in
Ring terminals		0.8 Nm / 7 Lb.in

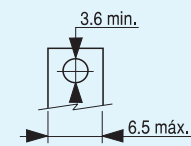

**Mechanical latch blocks**

	RMLF....
Rated insulation voltage(Ui)	1000V
Standard voltages (Us); 50-60Hz and direct current	24 ... 690V
Operating limits	0.75 to 1.1 xUs
Consumption for unlatching (auto cut-out)	210W /VA (24-72V) 130W /VA (110-440V)
Unlatching control <sup>(1)</sup>	
Electrical      Min.impuls	10 ms Maintained auto cut-out by integral contact 55-56 (only AC slots)
Manual	By local (O) push-button
Contactor control	
Electrical      Min.impuls	40 ms
Manual	By local (I) push-button
Mechanical endurance CL00 ... CL45	3 × 10 <sup>6</sup> (1200ops/h)
CL05 ... CL10	0.1 × 10 <sup>6</sup> (300 ops/h)

**Terminal capacity**

Solid, stranded and finely stranded without end sleeve	mm <sup>2</sup>	2 × 0.5 to 2.5 2 × 2.5 to 4
Finely stranded with end sleeve	mm <sup>2</sup>	2 × 0.5 to 2.5 2 × 2.5 to 4
AWG wires, solid and stranded	mm <sup>2</sup>	2 × 20 to 10
Tightening torque		0.8 Nm / 7 Lb.in

**Terminal numbering**

*Auxiliary contactors*

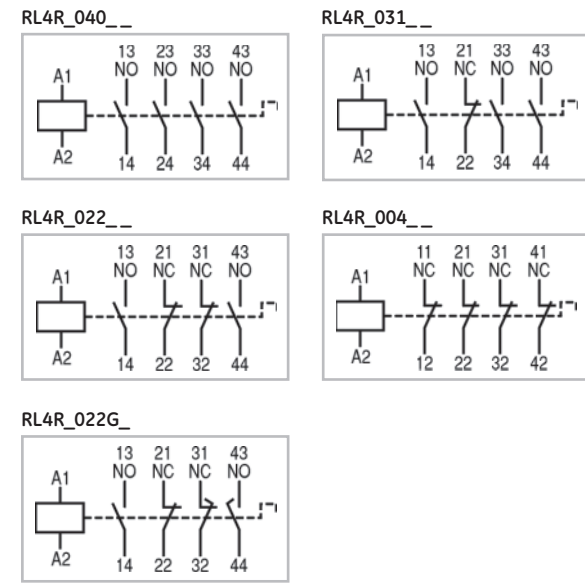

*Mechanical (-/electrical) interlock*

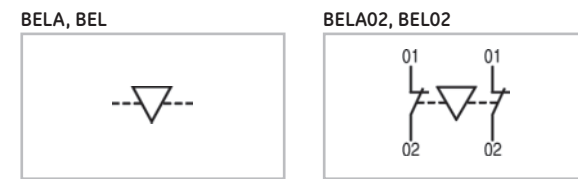

*Mechanical latch block*

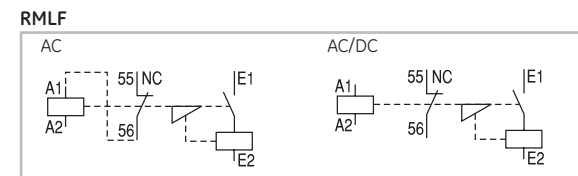

*Voltage suppressor blocks*

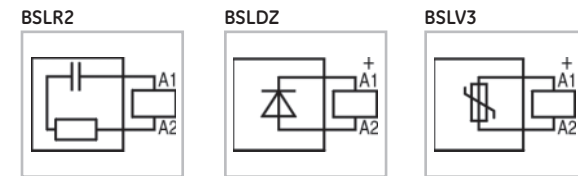

*Auxiliary contact blocks. Front mounting*

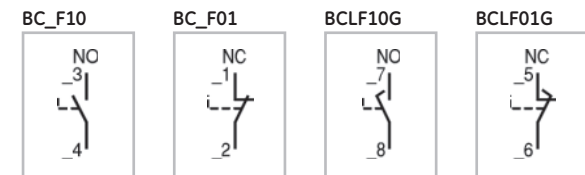

*Auxiliary contact blocks. Lateral mounting*

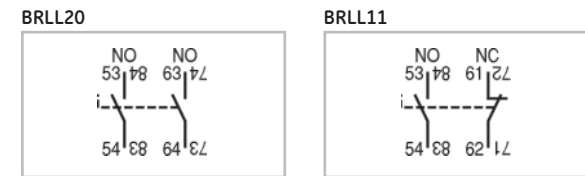

*Pneumatic timer blocks*

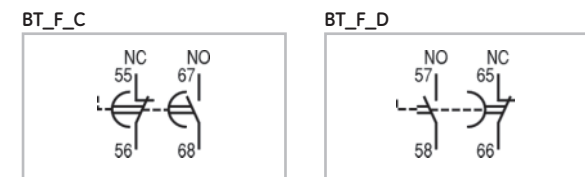

*Electronic timer blocks*

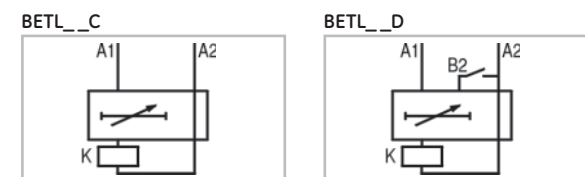

Technical data

Intro

A

**B**

C

D

E

F

G

H

I











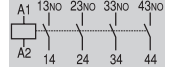

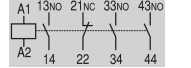

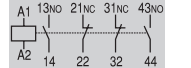

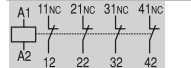

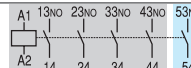

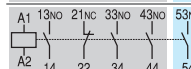

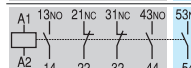

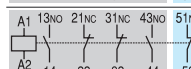

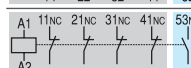

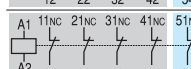

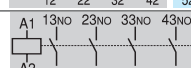

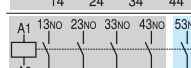

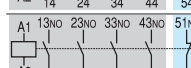
J/X

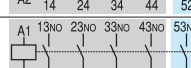

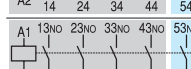
**Terminal numbering in accordance with EN 50011**

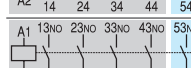
By combining other basic auxiliary contactors with auxiliary contact blocks BLC..., it is possible to obtain other combinations, and positions of contacts which are not covered by the table. But in all cases the maximum number of additional auxiliary contacts should be four.

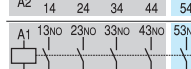
**Type E**  
Standard contact combination in which the interchangeability of the devices does not affect the cabling or the diagram. Specifies a particular contact numbering and positioning.

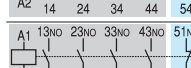
	Final structure of the combination	Auxiliary contacts		Auxiliary contactor +Auxiliary contact blocks to be added
		Combination Description	NO NC	
Type E	 	40E	4 0	RL4RA040...
	 	31E	3 1	RL4RA031...
	 	22E	2 2	RL4RA022...
	 	04E	0 4	RL4RA004...
	 	50E	5 0	RL4RA040... + BC_F10
	 	41E	4 1	RL4RA031... + BC_F10
	 	32E	3 2	RL4RA022... + BC_F10
	 	23E	2 3	RL4RA022... + BC_F01
	 	14E	1 4	RL4RA004... + BC_F10
	 	05E	0 5	RL4RA004... + BC_F01
	 	60E	6 0	RL4RA040... + BC_F10 + BC_F10
	 	51E	5 1	RL4RA040... + BC_F10 + BC_F01
	 	42E	4 2	RL4RA040... + BC_F01 + BC_F01
	 	80E	8 0	RL4RA040... + BC_F10 + BC_F10 + BC_F10 + BC_F10
	 	71E	7 1	RL4RA040... + BC_F10 + BC_F01 + BC_F10 + BC_F10
	 	62E	6 2	RL4RA040... + BC_F10 + BC_F01 + BC_F01 + BC_F10
	 	53E	5 3	RL4RA040... + BC_F10 + BC_F01 + BC_F01 + BC_F01
	 	44E	4 4	RL4RA040... + BC_F01 + BC_F01 + BC_F01 + BC_F01

- Auxiliary contactors
- Intro
- A
- B
- C
- D
- E
- F
- G
- H
- I
- J/X





Terminal numbering in accordance with EN 50011 (continued)

By combining other basic auxiliary contactors with auxiliary contact blocks BLC..., it is possible to obtain other combinations, and positions of contacts which are not covered by the table. But in all cases the maximum number of additional auxiliary contacts should be four.

Type Z

Contact combination the same as Type E.  
Interchangeability of the devices may affect the cabling and the diagram. Neither contact numbering nor positioning are retained.

Type Y

Contact combination which differs from Type E, although it is obtained by a combination of devices provided for this Type E.

	Final structure of the combination	Auxiliary contacts		Auxiliary contactor +Auxiliary contact blocks to be added
		Combination	Description	
Type Z	$A_1$ 13NO 23NO 33NO 43NO 53NO 63NO $A_2$ 14 24 34 44 54 64	6	0	RL4RA040... + BRL20
	$A_1$ 13NO 23NO 33NO 43NO 53NO 61NC $A_2$ 14 24 34 44 54 62	5	1	RL4RA040... + BRL11
	$A_1$ 13NO 23NO 33NO 43NO 53NO 63NO 73NO 83NO $A_2$ 14 24 34 44 54 64 74 84	8	0	RL4RA040... + BRL20 + BRL20
	$A_1$ 13NO 23NO 33NO 43NO 53NO 61NC 73NO 83NO $A_2$ 14 24 34 44 54 62 74 84	7	1	RL4RA040... + BRL11 + BRL20
Type Y	$A_1$ 13NO 23NO 33NO 43NO 53NO 61NC $A_2$ 14 24 34 44 54 62	4	2	RL4RA031... + BC_F10 + BC_F01
	$A_1$ 13NO 21NC 33NO 43NO 53NO 61NC $A_2$ 14 22 34 44 54 62	4	2	RL4RA031... + BRL11
	$A_1$ 13NO 21NC 33NO 43NO 53NO 61NC 71NC 83NO $A_2$ 14 22 34 44 54 62 72 84	5	3	RL4RA031... + BC_F10 + BC_F01 + BC_F01 + BC_F10
	$A_1$ 13NO 21NC 31NC 43NO 53NO 61NC 71NC 83NO $A_2$ 14 22 32 44 54 62 72 84	4	4	RL4RA022... + BC_F10 + BC_F01 + BC_F01 + BC_F10
	$A_1$ 13NO 21NC 31NC 43NO 53NO 61NC $A_2$ 14 22 32 44 54 62	3	3	RL4RA022... + BC_F10 + BC_F01
	$A_1$ 13NO 21NC 31NC 43NO 53NO 61NC $A_2$ 14 22 32 44 54 62	3	3	RL4RA022... + BRL11
	$A_1$ 13NO 23NO 33NO 43NO 55NC 67NO 73NO 83NO $A_2$ 14 24 34 44 56 68 74 84			RL4RA040... + BTLF...C + BRL20
	$A_1$ 13NO 23NO 33NO 43NO 57NO 65NC 73NO 83NO $A_2$ 14 24 34 44 58 66 74 84			RL4RA040... + BTLF...D + BRL20
	$A_1$ 13NO 23NO 33NO 43NO 55NC 67NO 71NC 83NO $A_2$ 14 24 34 44 56 68 72 84			RL4RA040... + BTLF...C + BRL11
	$A_1$ 13NO 23NO 33NO 43NO 57NO 65NC 71NC 83NO $A_2$ 14 24 34 44 58 66 72 84			RL4RA040... + BTLF...D + BRL11

Technical data

Intro

A

B

C

D

E

F

G

H

I

J/X



Dimensional drawings

Auxiliary contactors

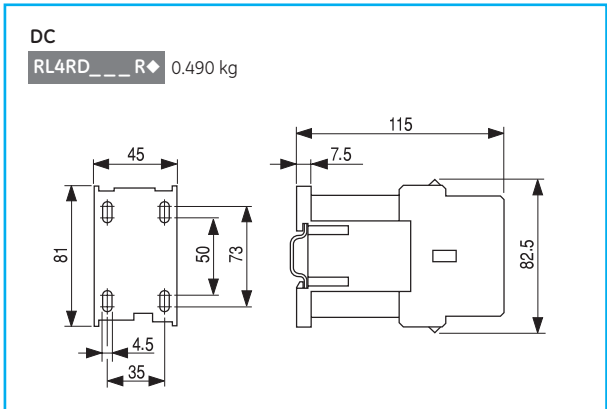
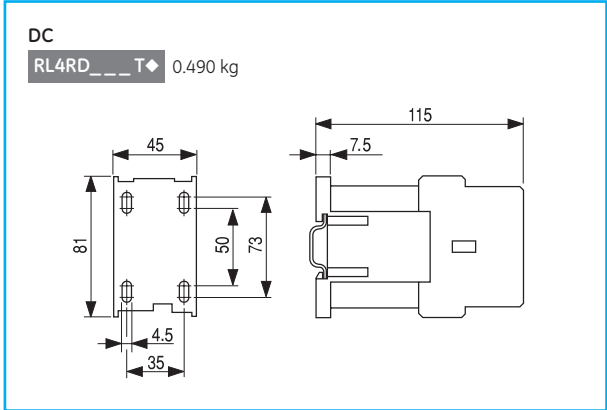
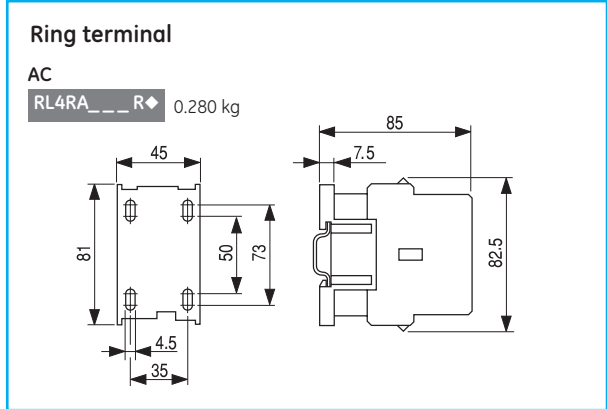
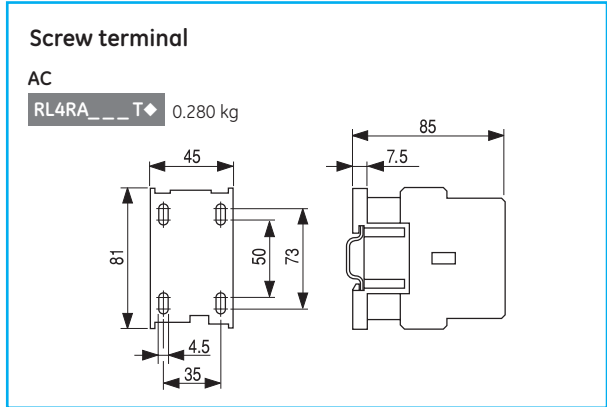

Instantaneous auxiliary contact blocks

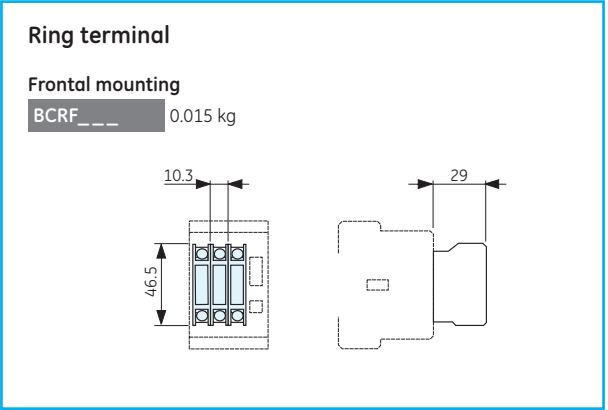
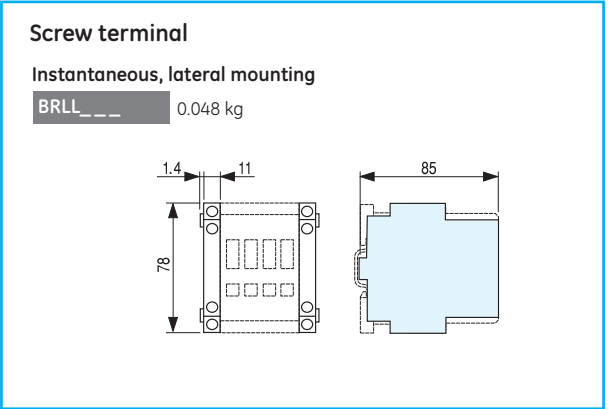
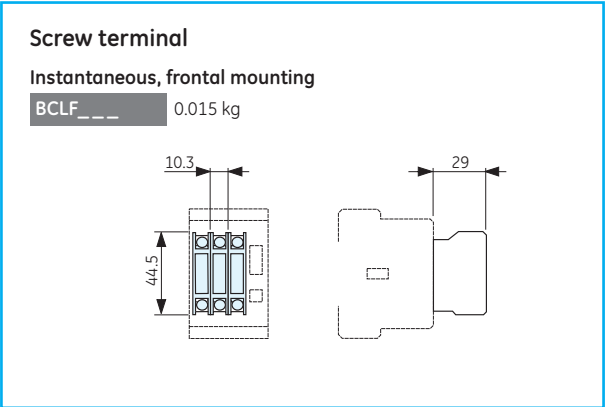

**Timed auxiliary contact blocks**

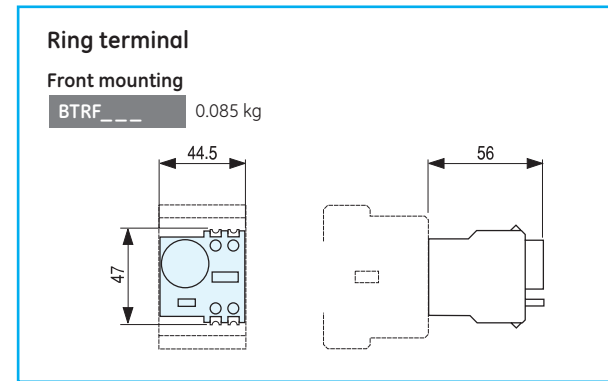
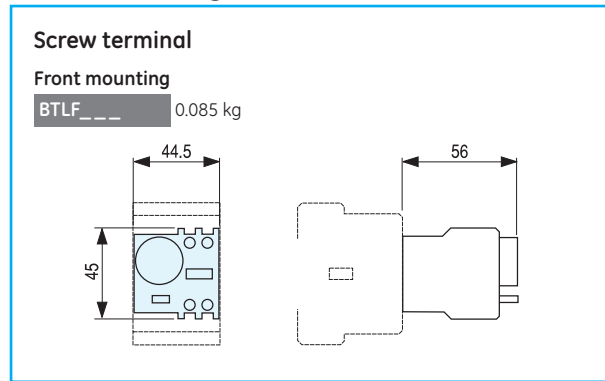

**Mechanical (-/electrical) interlock**

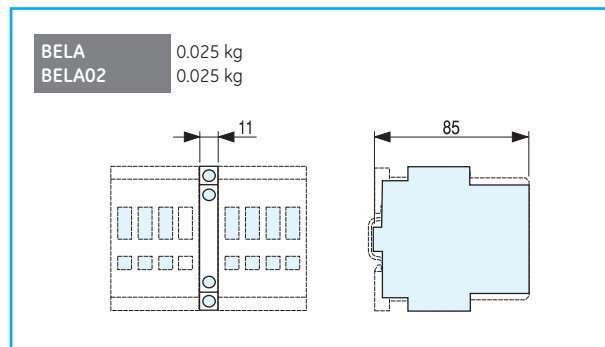

**Mechanical latch block**

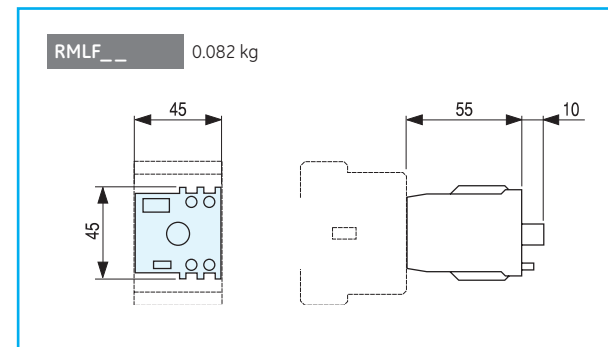

**Voltage suppressor blocks**

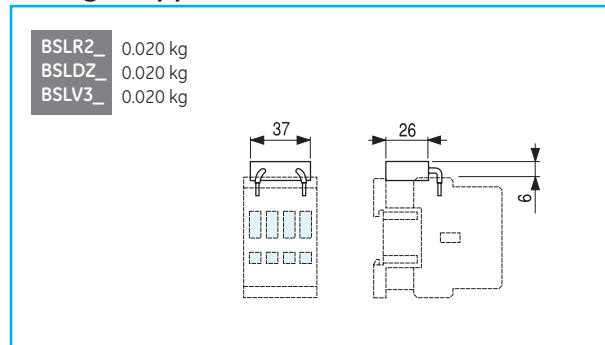

**Electronic timer block**

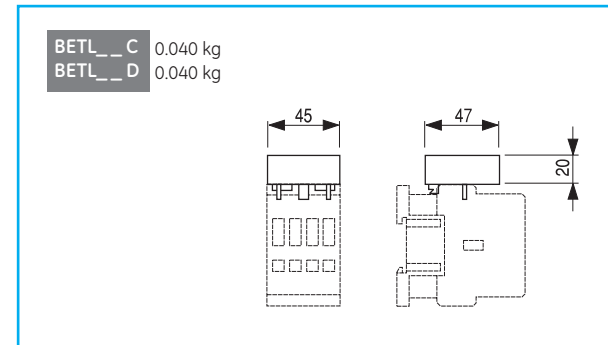

**Interface**

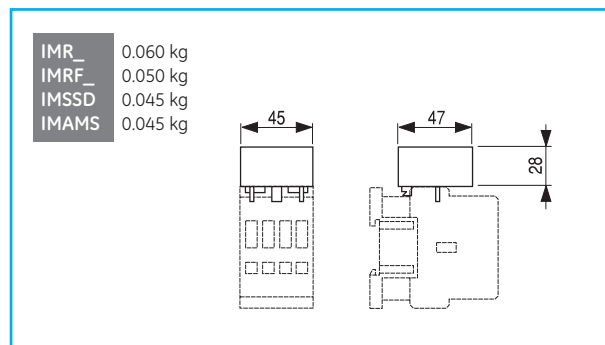

Dimensions

Intro

A

**B**

C

D

E

F

G

H

I

J/X



Notes

Grid area for notes.

Auxiliary contactors

Intro

A

B

C

D

E

F

G

H

I

J/X





**Thermal and magnetic protection**

**GPS1B**



**Standards/Approvals**

IEC 60947-1, 60947-2, 60947-4-1  
 DIN VDE 0660T 100/101/102  
 UL508/CSA - UL508/cULus  
 Shipping approvals:

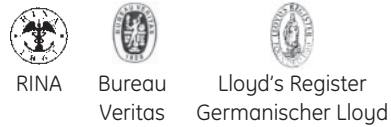

**Characteristics**

- Rocker and rotary handle operator
- Thermal and magnetic protection
- Standard and high breaking capacity  
 $I_{cu} = 100kA \geq I_{cs} = 100\% I_{cu}$   
 $I_{cu} < 100kA \geq I_{cs} \text{ min. } 75\% I_{cu}$
- Clear identification of the operation state (ON-OFF-tripped)
- Ambient temperature compensation
- Phase failure protection

**Auxiliaries**

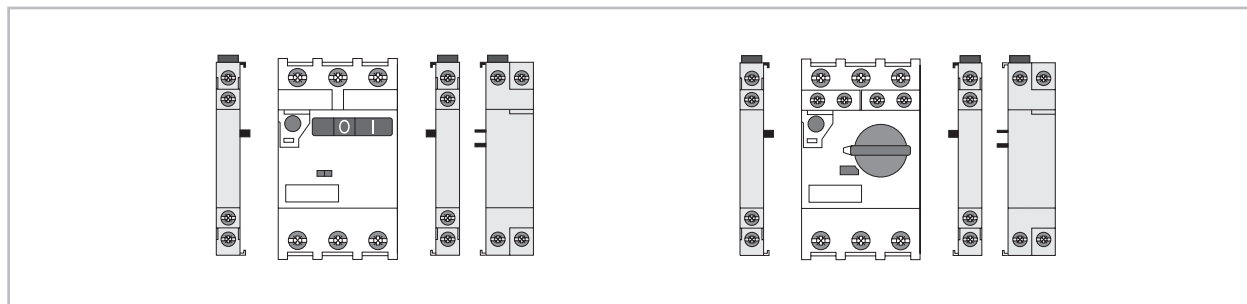

**Technical performances**

<b>Rated current <math>I_n</math></b>	(A)	0.1-32
<b>Rated operational current <math>I_e</math> (A)</b>		0.1-32
<b>Rated power at 400Vac</b>	(kW)	0.02-15
<b>Utilisation category</b>		
IEC 60947-2 (circuit breaker)		A
IEC 60947-4-1 (MMS)		AC-3
<b>Tripping class IEC 60947-4-1</b>		10
<b>Magnetic release <math>I_e \text{ max.}</math></b>	(A)	x13
<b>Mechanical/electrical endurance</b>		100,000

**Accessories**

- Auxiliaries ● pg. C.10
- Busbar system ● pg. C.13

- Technical data ● pg. C.18
- Dimensions ● pg. C.24
- Fuseless starters ● pg. C.14
- Coordination tables ● pg. D.11



**GPS1B - Standard breaking capacity**

CLASS 10	Rated power 3 phase motors at 400Vac Pn	Rated current In (1)	Thermal current setting range	Instantaneous short-circuit release	Rated ultimate short-circuit breaking capacity at 400V Icu (kA)	Rated service short-circuit breaking capacity at 400V Ics (kA)	Cat. no.	Ref. no.	Pack.
	(kW)	(A)	(A)	(A)					
	0.02	0.16	0.10 - 0.16	2.1	100	100	GPS1BSAA	101211	5
	0.06	0.25	0.16 - 0.25	3.3	100	100	GPS1BSAB	101212	5
	0.09	0.4	0.25 - 0.40	5.2	100	100	GPS1BSAC	101213	5
	0.12/0.18	0.63	0.40 - 0.63	8.2	100	100	GPS1BSAD	101214	5
	0.25	1	0.63 - 1.00	13	100	100	GPS1BSAE	101215	5
	0.37/0.55	1.6	1.0 - 1.6	20.8	100	100	GPS1BSAF	101216	5
	0.75	2.5	1.6 - 2.5	32.5	100	100	GPS1BSAG	101217	5
	1.5	4	2.5 - 4.0	52	100	100	GPS1BSAH	101218	5
	2.2	6.3	4.0 - 6.3	81.9	100	100	GPS1BSAJ	101219	5
	3/4	10	6.3 - 10	130	100	100	GPS1BSAK	101220	5
	5.5	13	9 - 13	169	50	38	GPS1BSAL	101221	5
	7.5	16	11 - 16	208	25	19	GPS1BSAM	101222	5
	10	20	14 - 20	260	25	19	GPS1BSAN	101223	5
	11	25	19 - 25	325	25	19	GPS1BSAP	101224	5
	15	32	24 - 32	416	25	19	GPS1BSAR	101225	5



(1) Rated current: highest thermal current setting range value.

**GPS1B - High breaking capacity.**

CLASS 10	Rated power 3 phase motors at 400Vac Pn	Rated current In (1)	Thermal current setting range	Instantaneous short-circuit release	Rated ultimate short-circuit breaking capacity at 400V Icu (kA)	Rated service short-circuit breaking capacity at 400V Ics (kA)	Cat. no.	Ref. no.	Pack.
	(kW)	(A)	(A)	(A)					
	0.02	0.16	0.10 - 0.16	2.1	100	100	GPS1BHAA	101234	5
	0.06	0.25	0.16 - 0.25	3.3	100	100	GPS1BHAB	101235	5
	0.09	0.4	0.25 - 0.40	5.2	100	100	GPS1BHAC	101236	5
	0.12/0.18	0.63	0.40 - 0.63	8.2	100	100	GPS1BHAD	101237	5
	0.25	1	0.63 - 1.00	13	100	100	GPS1BHA E	101238	5
	0.37/0.55	1.6	1 - 1.6	20.8	100	100	GPS1BHAF	101239	5
	0.75	2.5	1.6 - 2.5	32.5	100	100	GPS1BHAG	101240	5
	1.5	4	2.5 - 4.0	52	100	100	GPS1BHAH	101241	5
	2.2	6.3	4.0 - 6.3	81.9	100	100	GPS1BHAJ	101242	5
	3/4	10	6.3 - 10	130	100	100	GPS1BHAK	101243	5
	5.5	13	9 - 13	169	100	100	GPS1BHAL	101244	5
	7.5	16	11 - 16	208	50	38	GPS1BHAM	101245	5
	10	20	14 - 20	260	50	38	GPS1BHAN	101246	5
	11	25	19 - 25	325	50	38	GPS1BHAP	101247	5
	15	32	24 - 32	416	50	38	GPS1BHAR	101248	5



(1) Rated current: highest thermal current setting range value.

Order codes

Intro

A

B

**C**

D

E

F

G

H

I

J/X



### Thermal and magnetic protection

#### GPS2B



#### Standards/Approvals

IEC 60947-1, 60947-2, 60947-4-1  
DIN VDE 0660T 100/101/102  
UL508/CSA - UL508/cULus

Shipping approvals:



#### Characteristics

- Rotary handle operator
- Thermal and magnetic protection
- Standard and high breaking capacity  
 $I_{cu} = 100kA \geq I_{cs} = 100\% I_{cu}$   
 $I_{cu} < 100kA \geq I_{cs} \text{ min. } 75\% I_{cu}$
- Clear identification of the operation state (ON-OFF-tripped)
- Ambient temperature compensation
- Phase failure protection

#### Technical performances

<b>Rated current <math>I_n</math></b>	(A)	10-63
<b>Rated operational current <math>I_e</math></b>	(A)	10-63
<b>Rated power at 400Vac</b>	(kW)	4-30
<b>Utilisation category</b>		
IEC 60947-2 (circuit breaker)		A
IEC 60947-4-1 (MMS)		AC-3
<b>Tripping class IEC 60947-4-1</b>		10
<b>Magnetic release <math>I_e \text{ max.}</math></b>	(A)	x13
<b>Mechanical/electrical endurance</b>		50,000/25,000

#### Auxiliaries

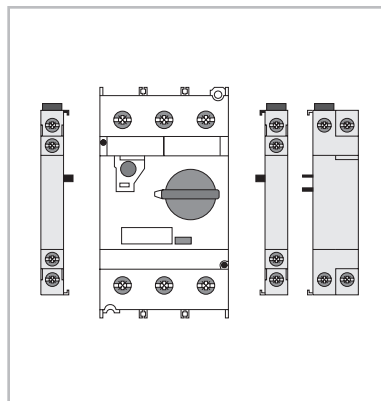

#### Accessories

- Auxiliaries ● pg. C.10
- Busbar system ● pg. C.13

- Technical data ● pg. C.18
- Dimensions ● pg. C.24
- Fuseless starters ● pg. C.14
- Coordination tables ● pg. D.11





**GPS2B - Standard breaking capacity**

CLASS 10	Rated power 3 phase motors at 400Vac Pn  (kW)	Rated current In (1)  (A)	Thermal current setting range  (A)	Instantaneous short-circuit release  (A)	Rated ultimate short-circuit breaking capacity at 400V Icu (kA)	Rated service short-circuit breaking capacity at 400V Ics (kA)	Cat. no.	Ref. no.	Pack.
	3/4	10	6.3 - 10	130	100	100	GPS2BSAK	101226	1
	5.5	13	9 - 13	169	50	38	GPS2BSAL	107119	1
	7.5	16	11 - 16	208	25	19	GPS2BSAM	101227	1
	10	20	14 - 20	260	25	19	GPS2BSAN	101228	1
	11	25	19 - 25	325	25	19	GPS2BSAP	101229	1
	15	32	24 - 32	416	25	19	GPS2BSAR	101230	1
	18.5	40	28 - 40	520	25	19	GPS2BSAS	101231	1
	22	50	35 - 50	650	25	19	GPS2BSAT	101232	1
	30	63	45 - 63	819	25	19	GPS2BSAU	101233	1



(1) Rated current: highest thermal current setting range value.

**GPS2B - High breaking capacity**

CLASS 10	Rated power 3 phase motors at 400Vac Pn  (kW)	Rated current In (1)  (A)	Thermal current setting range  (A)	Instantaneous short-circuit release  (A)	Short-circuit breaking capacity at 400V Icu (kA)	Short-circuit breaking capacity at 400V Ics (kA)	Cat. no.	Ref. no.	Pack.
	3/4	10	6.3 - 10	130	100	100	GPS2BHAK	101249	1
	5.5	13	9 - 13	169	100	100	GPS2BHAL	107120	1
	7.5	16	11 - 16	208	50	38	GPS2BHAM	101250	1
	10	20	14 - 20	260	50	38	GPS2BHAN	101251	1
	11	25	19 - 25	325	50	38	GPS2BHAP	101252	1
	15	32	24 - 32	416	50	38	GPS2BHAR	101253	1
	18.5	40	28 - 40	520	50	38	GPS2BHAS	101254	1
	22	50	35 - 50	650	50	38	GPS2BHAT	101255	1
	30	63	45 - 63	819	50	38	GPS2BHAU	101256	1



(1) Rated current: highest thermal current setting range value.

Order codes

Intro

A

B

C

D

E

F

G

H

I

J/X



**Magnetic protection**

**GPS1M**



**Standards/Approvals**

IEC 60947-1, 60947-2, 60947-4-1  
 DIN VDE 0660T 100/101/102  
 UL508/CSA - UL508/cULus

Shipping approvals:

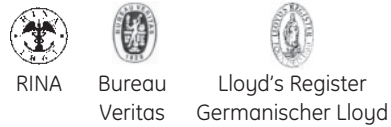

**Characteristics**

- Short-circuit protection for starters
- Rocker and rotary handle operator
- Magnetic protection
- Standard and high breaking capacity  
 $I_{cu} = 100kA \geq I_{cs} = 100\% I_{cu}$   
 $I_{cu} < 100kA \geq I_{cs} \text{ min. } 75\% I_{cu}$
- Clear identification of the operation state (ON-OFF-tripped)



**Auxiliaries**

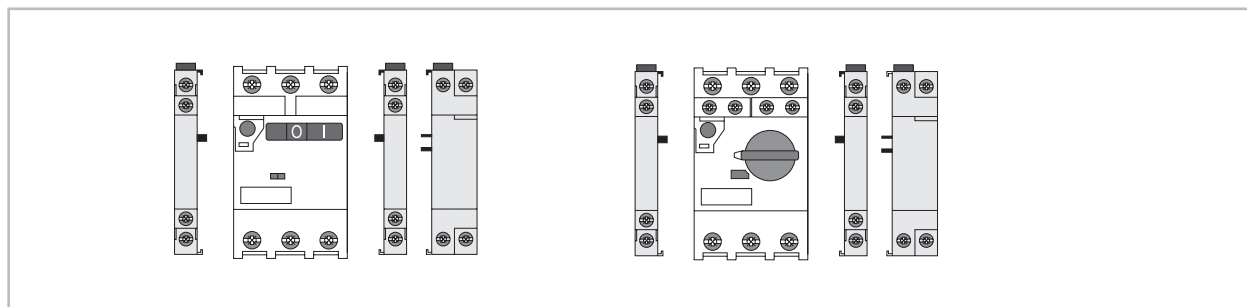

**Technical performances**

<b>Rated current <math>I_n</math></b>	(A) 0.1-32
<b>Rated operational current <math>I_e</math></b>	(A) 0.1-32
<b>Utilisation category</b>	A
<b>IEC 60947-2 (circuit breaker)</b>	
<b>Magnetic release <math>I_e \text{ max.}</math></b>	(A) x13
<b>Mechanical/electrical endurance</b>	100.000

**Accessories**

- Auxiliaries ● pg. C.10
- Busbar system ● pg. C.13

- Technical data ● pg. C.18
- Dimensions ● pg. C.24
- Fuseless starters ● pg. C.14
- Coordination tables ● pg. D.11



**GPS1M - Standard breaking capacity**



Rated power 3 phase motors at 400Vac Pn	Rated current In	Thermal current setting range (1)	Instantaneous short-circuit release	Rated ultimate short-circuit breaking capacity at 400V Icu (kA)	Rated service short-circuit breaking capacity at 400V Ics (kA)	Cat. no.	Ref. no.	Pack.
(kW)	(A)	(A)	(A)					
0.02	0.16	-	2.1	100	100	GPS1MSAA	101257	5
0.06	0.25	-	3.3	100	100	GPS1MSAB	101258	5
0.09	0.4	-	5.2	100	100	GPS1MSAC	101259	5
0.12/0.18	0.63	-	8.2	100	100	GPS1MSAD	101260	5
0.25	1	-	13	100	100	GPS1MSAE	101261	5
0.37/0.55	1.6	-	20.8	100	100	GPS1MSAF	101262	5
0.75	2.5	-	32.5	100	100	GPS1MSAG	101263	5
1.5	4	-	52	100	100	GPS1MSAH	101264	5
2.2	6.3	-	81.9	100	100	GPS1MSAJ	101265	5
3/4	10	-	130	100	100	GPS1MSAK	101266	5
5.5	13	-	169	50	38	GPS1MSAL	101267	5
7.5	16	-	208	25	19	GPS1MSAM	101268	5
10	20	-	260	25	19	GPS1MSAN	101269	5
11	25	-	325	25	19	GPS1MSAP	101270	5
15	32	-	416	25	19	GPS1MSAR	101271	5

(1) Select appropriate thermal overload relay for the starter. See chapter A pages A.70 - A.75.

**GPS1M - High breaking capacity**



Rated power 3 phase motors at 400Vac Pn	Rated current In	Thermal current setting range (1)	Instantaneous short-circuit release	Rated ultimate short-circuit breaking capacity at 400V Icu (kA)	Rated service short-circuit breaking capacity at 400V Ics (kA)	Cat. no.	Ref. no.	Pack.
(kW)	(A)	(A)	(A)					
0.02	0.16	-	2.1	100	100	GPS1MHAA	101280	5
0.06	0.25	-	3.3	100	100	GPS1MHAB	101281	5
0.09	0.4	-	5.2	100	100	GPS1MHAC	101282	5
0.12/0.18	0.63	-	8.2	100	100	GPS1MHAD	101283	5
0.25	1	-	13	100	100	GPS1MHA E	101284	5
0.37/0.55	1.6	-	20.8	100	100	GPS1MHA F	101285	5
0.75	2.5	-	32.5	100	100	GPS1MHA G	101286	5
1.5	4	-	52	100	100	GPS1MHA H	101287	5
2.2	6.3	-	81.9	100	100	GPS1MHA J	101288	5
3/4	10	-	130	100	100	GPS1MHA K	101289	5
5.5	13	-	169	100	100	GPS1MHA L	101290	5
7.5	16	-	208	50	38	GPS1MHA M	101291	5
10	20	-	260	50	38	GPS1MHA N	101292	5
11	25	-	325	50	38	GPS1MHA P	101293	5
15	32	-	416	50	38	GPS1MHA R	101294	5

(1) Select appropriate thermal overload relay for the starter. See chapter A pages A.70 - A.75.

Order codes

Intro

A

B

C

D

E

F

G

H

I

J/X



**Magnetic protection**

**GPS2M**



**Standards/Approvals**

IEC 60947-1, 60947-2, 60947-4-1  
 DIN VDE 0660T 100/101/102  
 UL508/CSA - UL508/cULus  
 Shipping approvals:



**Characteristics**

- Short-circuit protection for starters
- Rotary handle operator
- Magnetic protection
- Standard and high breaking capacity  
 $I_{cu} = 100kA \geq I_{cs} = 100\% I_{cu}$   
 $I_{cu} < 100kA \geq I_{cs} \text{ min. } 75\% I_{cu}$
- Clear identification of the operation state (ON-OFF-tripped)



**Auxiliaries**

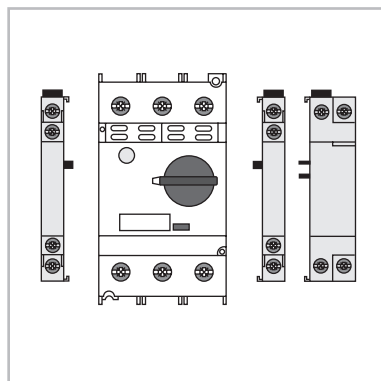

**Technical performances**

<b>Rated current <math>I_n</math></b>	(A) 10-63
<b>Rated operational current <math>I_e</math></b>	(A) 10-63
<b>Utilisation category</b>	A
IEC 60947-2 (circuit breaker)	
<b>Magnetic release <math>I_e \text{ max.}</math></b>	(A) x13
<b>Mechanical/electrical endurance</b>	50,000/25,000

**Accessories**

- Auxiliaries ● pg. C.10
- Busbar system ● pg. C.13

- Technical data ● pg. C.18
- Dimensions ● pg. C.24
- Fuseless starters ● pg. C.14
- Coordination tables ● pg. D.11



**GPS2M - Standard breaking capacity**



Rated power 3 phase motors at 400Vac Pn  (kW)	Rated current In  (A)	Thermal current setting range (1)  (A)	Instantaneous short-circuit release  (A)	Rated ultimate short-circuit breaking capacity at 400V Icu (kA)	Rated service short-circuit breaking capacity at 400V Ics (kA)	Cat. no.	Ref. no.	Pack.
4	10	-	130	100	100	GPS2MSAK	101272	1
5.5	13	-	169	50	38	GPS2MSAL	107121	1
7.5	16	-	208	25	19	GPS2MSAM	101273	1
10	20	-	260	25	19	GPS2MSAN	101274	1
11	25	-	325	25	19	GPS2MSAP	101275	1
15	32	-	416	25	19	GPS2MSAR	101276	1
18.5	40	-	520	25	19	GPS2MSAS	101277	1
22	50	-	650	25	19	GPS2MSAT	101278	1
30	63	-	819	25	19	GPS2MSAU	101279	1

(1) Select appropriate thermal overload relay for the starter. See chapter A pages A.72 - A.75.

**GPS2M - High breaking capacity**



Rated power 3 phase motors at 400Vac Pn  (kW)	Rated current In  (A)	Thermal current setting range (1)  (A)	Instantaneous short-circuit release  (A)	Rated ultimate short-circuit breaking capacity at 400V Icu (kA)	Rated service short-circuit breaking capacity at 400V Ics (kA)	Cat. no.	Ref. no.	Pack.
4	10	-	130	100	100	GPS2MHAK	101295	1
5.5	13	-	169	100	100	GPS2MHAL	107122	1
7.5	16	-	208	50	38	GPS2MHAM	101296	1
10	20	-	260	50	38	GPS2MHAN	101297	1
11	25	-	325	50	38	GPS2MHAP	101298	1
15	32	-	416	50	38	GPS2MHAR	101299	1
18.5	40	-	520	50	38	GPS2MHAS	101300	1
22	50	-	650	50	38	GPS2MHAT	101301	1
30	63	-	819	50	38	GPS2MHAU	101302	1

(1) Select appropriate thermal overload relay for the starter. See chapter A pages A.71 - A.75.

Order codes

Intro

A

B

C

D

E

F

G

H

I

J/X



Auxiliaries

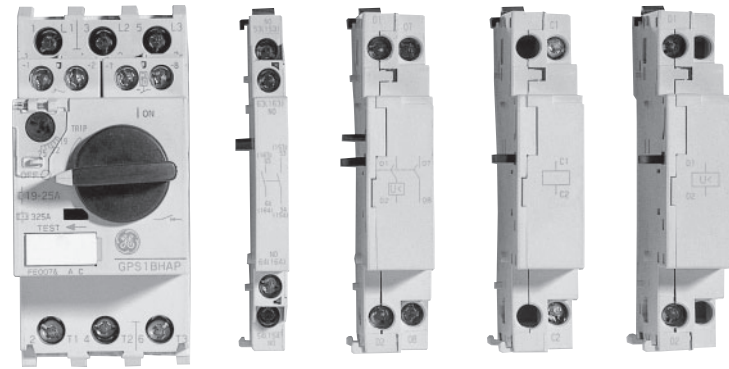
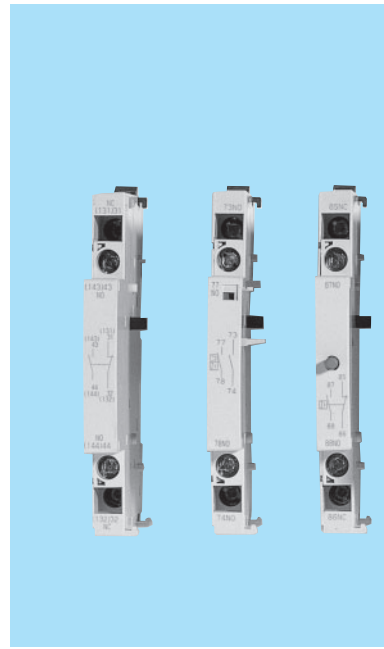

Standards/Approvals

IEC 60947-1, 60947-2, 60947-4-1  
 DIN VDE 0660T 100/101/102  
 UL508/CSA - UL508/cULus  
 Shipping approvals:



Product range

- Auxiliary contacts (frontal & lateral)
- Alarm contact block
- Auxiliary and alarm contact block
- Short-circuit alarm contact block
- Shunt trip
- Undervoltage release
- Undervoltage release with 2NO early make contacts
- External handle operator
- Terminal protector
- Busbar system

Auxiliaries

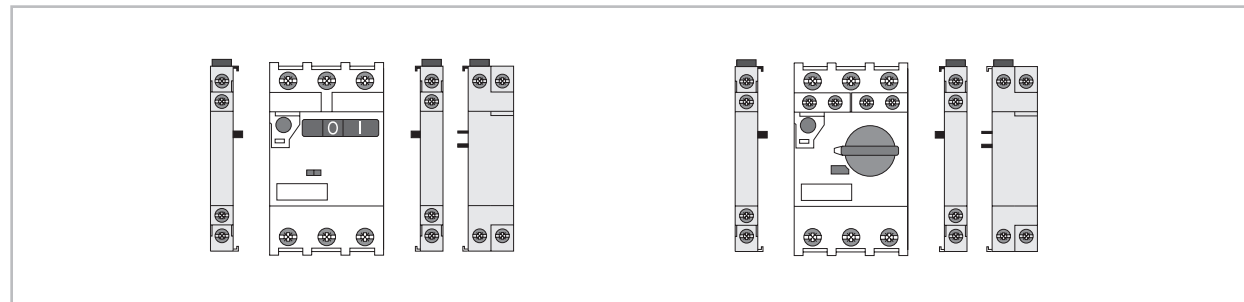

Technical performances

- All auxiliaries can be mounted and changed easily, without any tools
- Both frames GPS1 and GPS2 uses same auxiliaries
- All terminals are capable for 2 cables (0.5mm<sup>2</sup> - 2.5mm<sup>2</sup>)
- Side auxiliary contacts are rated to A600, P300 duty
- Frontal auxiliary contacts are rated to B300, Q300 duty
- Minimum operational contact 5mA, 17Vdc
- All terminal screwhead are Pozidriv 2 and slotted combination

Technical data ● pg. C.18  
 Dimensions ● pg. C.24  
 Fuseless starters ● pg. C.14  
 Coordination tables ● pg. D.11



**Auxiliary contact blocks**

	Description	For use with	Type	Cat. no.	Ref. no.	Pack.
<b>Frontal</b>	Maximum 2 auxiliary contact blocks per manual motor starter	.GPS1... and GPS2...	1 NO	GPAC10FBA	101303	10
		GPS1... and GPS2...	1 NC	GPAC01FBA	101304	10

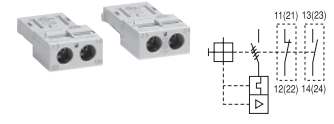

	Description	For use with	Type	Cat. no.	Ref. no.	Pack.
<b>Lateral</b>	Two contacts Side mounting on the left	.GPS1... and GPS2...	1 NO + 1 NC	GPAC11LLA	101305	10
		GPS1... and GPS2...	2 NO	GPAC20LLA	101306	10
		GPS1... and GPS2...	2 NC	GPAC02LLA	101307	10
	Two contacts Side mounting on the right	.GPS1... and GPS2...	1 NO + 1 NC	GPAC11LRA	101308	10
		GPS1... and GPS2...	2 NO	GPAC20LRA	101309	10
		GPS1... and GPS2...	2 NC	GPAC02LRA	101310	10

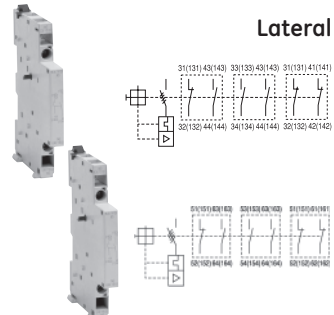

**Alarm contact block**

	Description	For use with	Type	Cat. no.	Ref. no.	Pack.
	Frontal mounting on the right Single contact	.GPS1... and GPS2...	1 NO	GPAL10FRA	101311	10
		GPS1... and GPS2...	1 NC	GPAL01FRA	101312	10

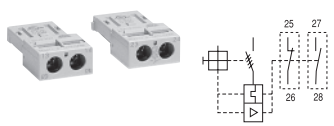

**Auxiliary / alarm contact block**

	Description	For use with	Type	Cat. no.	Ref. no.	Pack.
	Side mounting on the left (front alarm contact block can not be used at the same time) Two contacts	.GPS1... and GPS2... 1 NO(Alarm)+1 NO(Aux)		GPAD1010LLA	101313	10
		.GPS1... and GPS2... 1 NO(Alarm)+1 NC(Aux)		GPAD1001LLA	101314	10
		.GPS1... and GPS2... 1 NC(Alarm)+1 NO(Aux)		GPAD0110LLA	101315	10
		.GPS1... and GPS2... 1 NC(Alarm)+1 NC(Aux)		GPAD0101LLA	101316	10

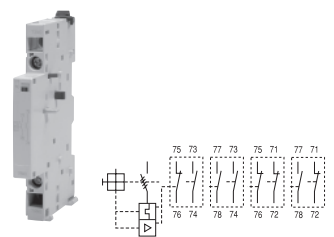

**Short-circuit alarm contact block**

	Description	For use with	Type	Cat. no.	Ref. no.	Pack.
	Side mounting on the left Two contacts NO + NC Mechanical indication marking	.GPS1... and GPS2...	1 NO + 1 NC	GPAE11LLA	101317	10

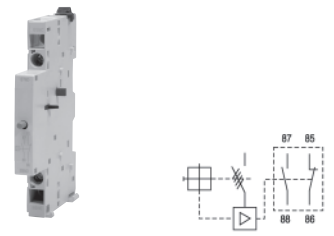

Order codes

Intro

A

B

C

D

E

F

G

H

I

J/X



**Shunt trip device**

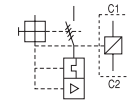

Description	For use with	Coil voltage	Cat. no.	Ref. no.	Pack.
Side mounting on the <b>right</b> Can not be used together with the undervoltage trip device	GPS1... and GPS2...	24V 50/60Hz	GPASLRAA1	101318	5
	GPS1... and GPS2...	48V 60Hz	GPASLRAAF	101319	5
	GPS1... and GPS2...	48V 50Hz / 60V 60Hz	GPASLRAAG	101320	5
	GPS1... and GPS2...	110/127V 50Hz / 120V 60Hz	GPASLRAAJ	101321	5
	GPS1... and GPS2...	208V 60Hz	GPASLRAAM	101322	5
	GPS1... and GPS2...	220/230V 50Hz / 240/260V 60Hz	GPASLRAAN	101323	5
	GPS1... and GPS2...	240V 50Hz / 277V 60Hz	GPASLRAAR	101324	5
	GPS1... and GPS2...	380/400V 50Hz	GPASLRAAU	101325	5
	GPS1... and GPS2...	415/440V 50Hz / 460/480V 60Hz	GPASLRAAW	101326	5
	GPS1... and GPS2...	500V 50Hz / 600V 60Hz	GPASLRAAY	101327	5
	GPS1... and GPS2...	24 to 60Vdc	GPASLRADD	101328	5
	GPS1... and GPS2...	110 to 240Vdc	GPASLRADJ	101329	5
	GPS1... and GPS2...	100V 50/60Hz	GPASLRAA11	101194	5

**Undervoltage trip device**

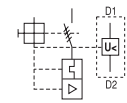

Description	For use with	Coil voltage	Cat. no.	Ref. no.	Pack.
Side mounting on the <b>right</b> Can not be used together with the shunt trip device	GPS1... and GPS2...	24V 50Hz	GPAULRAAD	101330	10
	GPS1... and GPS2...	24V 60Hz	GPAULRAAC	101331	10
	GPS1... and GPS2...	48V 50Hz	GPAULRAAG	101332	10
	GPS1... and GPS2...	48V 60Hz	GPAULRAAF	101333	10
	GPS1... and GPS2...	110/127V 50Hz / 120V 60Hz	GPAULRAAJ	101334	10
	GPS1... and GPS2...	208V 60Hz	GPAULRAAM	101335	10
	GPS1... and GPS2...	220/230V 50Hz / 240/260V 60Hz	GPAULRAAN	101336	10
	GPS1... and GPS2...	240V 50Hz / 277V 60Hz	GPAULRAAR	101337	10
	GPS1... and GPS2...	380/400V 50Hz	GPAULRAAU	101338	10
	GPS1... and GPS2...	415/440V 50Hz / 460/480V 60Hz	GPAULRAAW	101339	10
	GPS1... and GPS2...	500V 50Hz / 600V 60Hz	GPAULRAAY	101340	10
	GPS1... and GPS2...	100V 50/60Hz	GPAULRAA11	102625	10

**With 2NO early make auxiliary contacts**

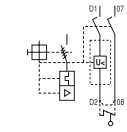

Description	For use with	Coil voltage	Cat. no.	Ref. no.	Pack.
Side mounting on the <b>right</b> Can not be used together with the shunt trip device	GPS1*S...	24V 50Hz	GPAU20LTAAD	101341	10
	GPS1*S...	24V 60Hz	GPAU20LTAAC	101342	10
	GPS1*S...	48V 50Hz	GPAU20LTAAG	101343	10
	GPS1*S...	48V 60Hz	GPAU20LTAAF	101344	10
	GPS1*S...	110/127V 50Hz / 120V 60Hz	GPAU20LTAAJ	101345	10
	GPS1*S...	208V 60Hz	GPAU20LTAAM	101346	10
	GPS1*S...	220/230V 50Hz / 240/260V 60Hz	GPAU20LTAAN	101347	10
	GPS1*S...	240V 50Hz / 277V 60Hz	GPAU20LTAAR	101348	10
	GPS1*S...	380/400V 50Hz	GPAU20LTAAU	101349	10
	GPS1*S...	415/440V 50Hz / 460/480V 60Hz	GPAU20LTAAW	101350	10
	GPS1*S...	500V 50Hz / 600V 60Hz	GPAU20LTAAY	101351	10
	GPS1*S...	100V 50/60Hz	GPAU20LTA11	110360	10

**With 2NO early make auxiliary contacts**

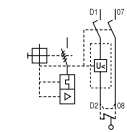

Description	For use with	Coil voltage	Cat. no.	Ref. no.	Pack.
Side mounting on the <b>right</b> Can not be used together with the shunt trip device	GPS1*H and GPS2...	24V 50Hz	GPAU20LCAAD	101352	10
	GPS1*H and GPS2...	24V 60Hz	GPAU20LCAAC	101353	10
	GPS1*H and GPS2...	48V 50Hz	GPAU20LCAAG	101354	10
	GPS1*H and GPS2...	48V 60Hz	GPAU20LCAAF	101355	10
	GPS1*H and GPS2...	110/127V 50Hz / 120V 60Hz	GPAU20LCAAJ	101356	10
	GPS1*H and GPS2...	208V 60Hz	GPAU20LCAAM	101357	10
	GPS1*H and GPS2...	220/230V 50Hz / 240/260V 60Hz	GPAU20LCAAN	101358	10
	GPS1*H and GPS2...	240V 50Hz / 277V 60Hz	GPAU20LCAAR	101359	10
	GPS1*H and GPS2...	380/400V 50Hz	GPAU20LCAAU	101360	10
	GPS1*H and GPS2...	415/440V 50Hz / 460/480V 60Hz	GPAU20LCAAW	101361	10
	GPS1*H and GPS2...	500V 50Hz / 600V 60Hz	GPAU20LCAAY	101362	10
	GPS1*H and GPS2...	100V 50/60Hz	GPAU20LCA11	112185	10

**Terminal protector**

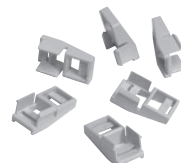

101509      107182

Description	For use with	Cat. no.	Ref. no.	Pack.
Snap-in tabs for screw mounting (set of 10)	GPS1*	GPAKS1A	101509	1
IP20 terminal covers	GPS2*	GPAPTP2A	107182	50
DIN rail vibration clamps	GPS1* / GPS2*	GPVDA	101514	2
Panel vibration clamps	GPS1* / GPS2*	GPVPA	101515	2

Increases vibration resistance of GPS1\* from 5G to 8G (5-150 Hz) in all directions. One clamp must be mounted on each side which increases total mounting width by 22 mm (0.87").  
For vibration resistance of GPS2\*, contact customers service.





**External handle operator**



Description	For use with	Type	Cat. no.	Ref. no.	Pack.
Used for distance mounting on a panel Lockable with 1, 2 or 3 padlocks diameter 4 to 8 mm Two types: standard and emergency applications ON/OFF/TRIPPING position marking Protection degree: IP54 Shaft mounting depths: 139.8 - 289.8 mm for GPA1HAB, GPA1HAR 161 - 311.1 mm for GPA2HAB, GPA2HAR Package parts and quantities: 1 handle unit 1 shaft 1 shaft guide 1 latch (screws) 4 mounting screws	GPS1*H...	Standard (black)	<b>GPA1HAB</b>	101363	5
	GPS1*H ...	Emergency (red/yellow)	<b>GPA1HAR</b>	101364	5
	GPS2...	Standard (black)	<b>GPA2HAB</b>	101502	5
	GPS2 ...	Emergency (red/yellow)	<b>GPA2HAR</b>	101503	5

**Busbar system**

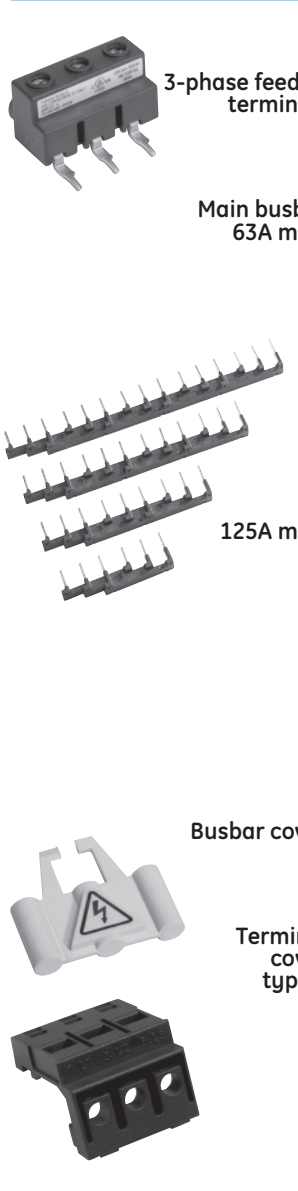

Description	For use with	Connection	Cat. no.	Ref. no.	Pack.	
<b>3-phase feed-in terminals</b>	Main feeding terminal Upper connection	GPS1...	Terminal capacity: 25 mm <sup>2</sup> Pin	<b>GPB1FA</b>	107186	10
		GPS2...	Terminal capacity: 50 mm <sup>2</sup> Pin	<b>GPB2FA</b>	107187	10
		GPS1...	Terminal capacity: 25mm <sup>2</sup> Fork	<b>SFVB8</b>	254537	1
<b>Main busbar 63A max.</b>	Modular spacing 45 mm	for 2 GPS1... + frontal auxiliaries	Pin	<b>GPB1B02A</b>	101390	5
		for 3 GPS1... + frontal auxiliaries	Pin	<b>GPB1B03A</b>	101391	5
		for 4 GPS1... + frontal auxiliaries	Pin	<b>GPB1B04A</b>	101392	5
		for 5 GPS1... + frontal auxiliaries	Pin	<b>GPB1B05A</b>	101393	5
	Modular spacing 54 mm	for 2 GPS1... + 9mm lateral aux.	Pin	<b>GPB1B12A</b>	101394	5
		for 3 GPS1... + 9mm lateral aux.	Pin	<b>GPB1B13A</b>	101395	5
		for 4 GPS1... + 9mm lateral aux.	Pin	<b>GPB1B14A</b>	101396	5
		for 5 GPS1... + 9mm lateral aux.	Pin	<b>GPB1B15A</b>	101397	5
		Modular spacing 63 mm	for 2 GPS1... + 18mm lateral aux. or 2 x 9mm lateral auxiliary	Fork	<b>GPB1B22A</b>	101398
	for 4 GPS1... + 18mm lateral aux. or 2 x 9mm lateral auxiliary		Fork	<b>GPB1B24A</b>	101399	10
Modular spacing 55 mm	for 2 GPS2... + frontal auxiliaries	Pin	<b>GPB2B02A</b>	101400	1	
	for 3 GPS2... + frontal auxiliaries	Pin	<b>GPB2B03A</b>	101401	1	
	for 4 GPS2... + frontal auxiliaries	Pin	<b>GPB2B04A</b>	101402	1	
Modular spacing 64 mm	for 2 GPS2... + 9mm lateral aux.	Pin	<b>GPB2B12A</b>	101403	1	
	for 3 GPS2... + 9mm lateral aux.	Pin	<b>GPB2B13A</b>	101404	1	
	for 4 GPS2... + 9mm lateral aux.	Pin	<b>GPB2B14A</b>	101405	1	
Modular spacing 73 mm	for 2 GPS2... + 18mm lateral aux. or 2 x 9mm lateral auxiliary	Pin	<b>GPB2B22A</b>	101406	1	
	for 4 GPS2... + 18mm lateral aux. or 2 x 9mm lateral auxiliary	Pin	<b>GPB2B24A</b>	101407	1	
<b>Busbar cover</b>	Touch guard for non used space	GPS1...	Pin	<b>GPB1GA</b>	101408	10
		GPS1...	Fork	<b>GPB1GAF</b>	101511	1
		GPS2...	Pin	<b>GPB2GA</b>	101409	10
<b>Terminal cover type E</b>	For compliance UL508E	GPS1...H	-	<b>GPAPT1E</b>	107315	1

When using a Surion GPS1\*BH as a manual self-protected combination motor starter (Type E).  
Cover enables compliance with NEC Section 430-52, 1" over air creepage and over surface clearance, phase to phase on the line side.

Order codes

Intro

A

B

C

D

E

F

G

H

I

J/X



**Fuseless starters and busbar adapter plates**

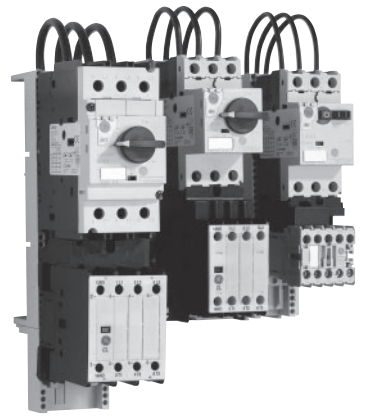
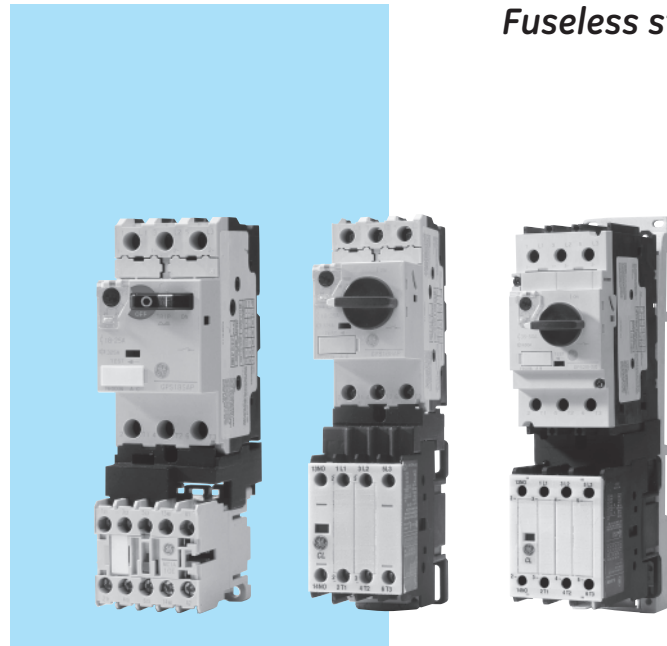

**Product range**

- Link modules for mechanical and electrical connection of the manual motor starter and the M / CL contactor range
- Base plates for Din rail and busbar adapters
- Wiring kits for reversing applications
- Link connection for two base plates for three phase busbar system with 40 and 60mm center line spacing and 5 to 10mm thickness
- Accessories

**Technical performances**

- Compact and high performance solution
- Easy accessibility to the contactor coil terminal A1-A2
- Save spacing only using 45 and 55mm width base plates for busbar adapters
- Quick "clip on" and secure connections
- Minimum 50kA short-circuit breaking capacity applies throughout



For fuseless starter application turn the contactor 180° to have direct accessibility to the A1-A2 coil terminals when contactor is assembled to the manual motor starter. Then fit the contactor plastic cover into the contactor front to have the terminal numbering in the correct position.  
 Note: when turning the contactor 180° the built-in auxiliary contact (in case) will be located on the first left side terminal.

- Thermal and magnetic protection**
- GPS1B ● pg. C.2
  - GPS2B ● pg. C.4
  - GPS1M ● pg. C.6
  - GPS2M ● pg. C.8
- Contactors**
- Serie M ● pg. A.44
  - Serie CL ● pg. A.52
- Coordination tables ● pg. D.11  
 Dimensions ● pg. D.40



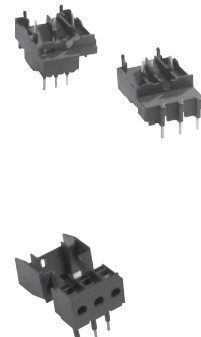

Fuseless starters

	Description	For use with contactor	ac/dc	Frame size	Cat. no.	Ref. no.	Pack.
<b>Link modules</b> 	For mechanical and electrical connection between contactors and manual motor starters	MC0.., MC1..	ac/dc	GPS1	<b>GPF1LMCBA</b>	101410	5
		CL00A.., CL01A.., CL02A..	ac	GPS1	<b>GPF1L02AA</b>	101411	5
		CL00D.., CL01D.., CL02D..	dc	GPS1	<b>GPF1L02DA</b>	101412	5
		CL25A..	ac	GPS1	<b>GPF1L25AA</b>	101413	5
		CL25D..	dc	GPS1	<b>GPF1L25DA</b>	101414	5
		CL03A.., CL04A..	ac	GPS1	<b>GPF1L04AA</b>	107165	5
		CL03D.., CL04D..	dc	GPS1	<b>GPF1L04DA</b>	107166	5
		CL03A.., CL04A..	ac	GPS2	<b>GPF2L04AA</b>	107190	5
		CL45A..	ac	GPS2	<b>GPF2L45AA</b>	101415	5
		CL03D.., CL04D..	dc	GPS2	<b>GPF2L04DA</b>	107191	5
		CL45D..	dc	GPS2	<b>GPF2L45DA</b>	101416	5
		CL06A.., CL07A..	ac	GPS2	<b>GPF2L07AA</b>	101417	5
		<b>Record Plus with CL09/10A</b> For mechanical and electrical connection between contactor and thermal overload relays RT1	CL00.. - CL25	ac/dc	GPS1	<b>GPF1L25CT1</b>	101512
CL03.. - CL45	ac/dc		GPS2	<b>GPF1L45CT1</b>	101513	5	
<b>Base plates</b> 	Plastic plates for mounting the fuseless starter in panels or in 35 mm DIN rail	CL00.., CL01.., CL02.., CL25..	ac/dc	GPS1	<b>GPF1B1A</b>	101418	5
		CL03.., CL04.., and CL45..	ac/dc	GPS2	<b>GPF2B2A</b>	101419	5
		CL06.., CL07..	ac/dc	GPS2	<b>GPF2B3A</b>	101420	5
		CL03.., CL04..	ac/dc	GP	<b>GPF1B4A</b>	107163	5
<b>Base plates</b> For use with MCCB Record Plus	-	-	-	<b>GPF3B5A</b>	107253	1	
<b>Link connector</b> For two base plates for reversing applications	-	-	-	<b>GPF1CBA</b>	101427	10	
<b>Plastic cover</b> 	Fit the plastic cover into the front of the correspondent contactor to allow a clear identification of the terminal numbering	CL00.., CL01.. and CL02 without built-in auxiliary contact			<b>GPF00C02</b>	107098	5
		CL00.., CL01.. and CL02 with built-in 1NO auxiliary contact			<b>GPF10C02</b>	107099	5
		CL00.., CL01.. and CL02 with built-in 1NC auxiliary contact			<b>GPF01C02</b>	107100	5
		CL25..			<b>GPF00C25</b>	107101	2
		CL03.., CL04.. without built-in auxiliary contact			<b>GPF00C04</b>	107102	5
		CL03.., CL04.. with built-in 1NO auxiliary contact			<b>GPF10C04</b>	107103	5
		CL03.., CL04.. with built-in 1NC auxiliary contact			<b>GPF01C04</b>	107105	5
		CL45..			<b>GPF00C45</b>	107106	5
		CL06.., CL07..			<b>GPF00C08</b>	107107	5

Order codes

Intro

A

B

C

D

E

F

G

H

I

J/X





### Enclosures for manual motor starters

#### Product range

- Surface and flush mounting plastic enclosures (IP41 and IP55)
- Neutral and ground connection
- Three different types of push-buttons
  - Mushroom with impulse function
  - Mushroom self latching, unlatching by turning
  - Mushroom self latching, unlatching with a key
- Indicator lamps
- Padlocking device for three padlocks
- Conversion kit IP41 to IP55

#### Technical performances

- Used with GPS1\*S manual motor starters
- Protection degree IP41 or IP55
- Possibility to mount frontal/lateral auxiliary contact blocks with an undervoltage release (without or with 2NO early make auxiliary contacts) inside the enclosures

#### Manual motor starter





- GPS1B ● pg. C.2
- GPS2B ● pg. C.4
- GPS1M ● pg. C.6
- GPS2M ● pg. C.8



**Enclosures for only GPS 1\*S**

	Description	Cat. no.	Ref. no.	Pack.
 <b>Plastic enclosures</b>	Surface mounting IP41	GPE41A	101365	1
	Surface mounting IP55	GPE55A	101366	1
	Flush mounting IP41	GPEF41A	101367	1
	Flush mounting IP55	GPEF55A	101368	1

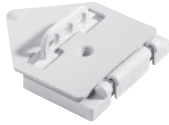
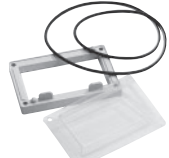
**Mounting accessories for all enclosures**

	Description	Cat. no.	Ref. no.	Pack.
 <b>Neutral connection</b>	To be used inside the enclosure	GPENA	101369	1
 <b>Adaptor set</b>	For enclosures used with GPS1*S and undervoltage release with 2 NO auxiliary contacts	GPEUTA	107097	1
 <b>Padlocking device</b>	For three padlocks with max. 8 mm shackle diameter Not to be used with emergency stop handle	GPEPA	101370	1
 <b>Conversion kit IP41 to IP55</b>		GPECA	101371	1
 <b>Mushroom push-button</b>	Mushroom spring return	GPEPMA	101372	1
	Mushroom self latching, turn to release	GPEPLA	101373	1
	Mushroom self latching, release with a key	GPEPKA	101374	1
 <b>Indicator lamps</b>	Green 110/120V	GPELGAJ	101375	1
	Green 220/240V	GPELGAN	101376	1
	Green 380/440V	GPELGAU	101377	1
	Green 480/500V	GPELGAX	101378	1
	Green 600V	GPELGAY	101379	1
	Red 110/120V	GPELRAJ	101380	1
	Red 220/240V	GPELRAN	101381	1
	Red 380/440V	GPELRAU	101382	1
	Red 480/500V	GPELRAX	101383	1
	Red 600V	GPELRAY	101384	1
	Transparent 110/120V	GPELCAJ	101385	1
	Transparent 220/240V	GPELCAN	101386	1
	Transparent 380/440V	GPELCAU	101387	1
	Transparent 480/500V	GPELCAX	101388	1
	Transparent 600V	GPELCAY	101389	1

Order codes

Intro

A

B

C

D

E

F

G

H

I

J/X



## Technical data

### General data

Frame size	GPS1	GPS2
Rated insulation voltage Ui	690V	1000V
Rated operating voltage Ue	690V ac	690V ac
Rated impulse withstand strength Uimp	6kV	8kV
Rated frequency	50/60Hz	50/60Hz
Total power loss P (W)	0.16 to 25A 7W 32A 8.5W	up to 32A 11W 40A to 50A 15W 63A 17W
Utilisation category: IEC 947-2 (Circuit breaker)	Cat. A	Cat. A
IEC 947-4-1 (Motor starter)	AC3	AC3
Mechanical operational performance	100,000 (70,000 for 32A)	50,000
Electrical operational performance	100,000 (70,000 for 32A)	25,000
Max.operations per hour (motor start-up)	25	25
Ambient conditions: Storage temperature	-40°C to +80°C	-40°C to +80°C
Operation temperature	-25°C to +60°C	-25°C to +60°C
Temperature compensation	-20°C to +60°C	-20°C to +60°C
Ambient temperature compensation	yes	yes
Operational altitude	up to 2000m	up to 2000m
Shock resistance (IEC 68)	30g (width 20ms)	30g (width 20ms)
Vibration resistance	8g (5 to 150Hz)	8g (5 to 150Hz)
Shock -hazard prot. (acc.DIN VDE 0106)	fingerproof	fingerproof
Protection degree (acc.to IEC529)	IP20	IP10 (IP20 with acc GPAPT2A)
Rated current Ie	up to 32A	up to 63A
Overload protection	IEC 947-4-1	IEC 947-4-1
Phase failure protection	yes	yes
Tripping class	10	10
Magnetic release (factory set)	13 x I <sub>emax</sub>	13 x I <sub>emax</sub>
Test trip button	yes	yes
Standards & Approvals IEC 947-1 / -2 / -4-1	yes	yes
DIN VDE 0660T 100 / 101 / 102	yes	yes
UL508	yes	yes
UL508 type E	Only GPS1*H	yes
CE	yes	yes
cULus	yes	yes
D / S / N / Fi	In process	-
Shipping approvals	yes	yes

### Mounting data

Terminal capacity: Solid or stranded without end sleeve	1 x 1..10 mm <sup>2</sup> 2 x 1..6 mm <sup>2</sup>	1 or 2 x 1..25 mm <sup>2</sup>
Stranded with end sleeve AWG	1 or 2 x 1..6 mm <sup>2</sup> 1 x 18..8 / 2 x 18..10	1 x 1..25 mm <sup>2</sup> / 2 x 1..16 mm <sup>2</sup> 1 x 18..2 / 2 x 18..4
Operating mechanism lockable in OFF position diameter (mm)	3.5 to 4.5	3.5 to 4.5
Terminal type	screw	box
Tightening torque	2 Nm / 18Lb.in	5 Nm / 45 Lb.in
Screwdriver	Pz2 / slotted combination	Pz2 / slotted combination
Mounting: DIN-rail	yes	yes
Screws	no	yes
Operating position: turning to the front	30°	30°
turning to the back	90°	90°
turning to both sides	180°	180°
Handle operation	Rocker level / Rotary	Rotary
Dimensions width (mm)	45	55
height (mm)	90	120
depth (mm)	(GPS1*S) 75 / 92.5 (GPS1*H)	107.5



Back-up gl/gG fuses only if  $I_{cs} > I_{cu}$  (kA)

For ranges GPS1BSA* / GPS1MSA*																			
gl/gG fuses (A)	A 1.6	B 0.25	C 0.4	D 0.63	E 1	F 1.6	G 2.5	H 4	J 6.3	K 10	L 13	M 16	N 20	P 25	R 32	S 40	T 50	U 63	
230V	#	#	#	#	#	#	#	#	#	#	#	#	#	100	100	100	-	-	-
400V	#	#	#	#	#	#	#	#	#	#	80	100	100	100	100	-	-	-	
440V	#	#	#	#	#	#	#	#	#	50	63	80	80	80	80	-	-	-	
500V	#	#	#	#	#	#	#	#	50	50	63	63	63	80	80	-	-	-	
600V	#	#	#	#	#	#	20	32	40	50	63	63	63	80	80	-	-	-	
690V	#	#	#	#	#	#	20	32	40	50	50	63	63	63	63	-	-	-	

For ranges GPS1BHA* / GPS1MHA*																			
230V	#	#	#	#	#	#	#	#	#	#	#	#	#	#	#	#	-	-	-
400V	#	#	#	#	#	#	#	#	#	#	#	100	125	125	125	-	-	-	
440V	#	#	#	#	#	#	#	#	#	63	63	80	80	100	100	-	-	-	
500V	#	#	#	#	#	#	#	#	#	50	63	80	80	80	80	-	-	-	
600V	#	#	#	#	#	#	25	40	50	50	63	63	63	80	80	-	-	-	
690V	#	#	#	#	#	#	25	40	50	50	63	63	63	63	63	-	-	-	

For ranges GPS2BSA* / GPS2MSA*																		
230V	-	-	-	-	-	-	-	-	#	#	#	#	125	125	125	125	125	160
400V	-	-	-	-	-	-	-	-	#	80	100	125	125	125	125	125	125	160
440V	-	-	-	-	-	-	-	-	63	63	80	80	100	100	125	125	125	
500V	-	-	-	-	-	-	-	-	63	63	80	80	80	80	100	100	125	
600V	-	-	-	-	-	-	-	-	63	63	63	63	80	80	100	100	100	
690V	-	-	-	-	-	-	-	-	63	63	63	63	63	63	63	80	100	

For ranges GPS2BHA* / GPS2MHA*																		
230V	-	-	-	-	-	-	-	-	#	#	#	#	#	#	#	#	#	#
400V	-	-	-	-	-	-	-	-	#	#	100	125	125	125	125	125	125	160
440V	-	-	-	-	-	-	-	-	63	63	80	80	100	100	125	125	125	
500V	-	-	-	-	-	-	-	-	63	63	80	80	80	80	100	100	125	
600V	-	-	-	-	-	-	-	-	80	63	63	63	80	80	100	100	100	
690V	-	-	-	-	-	-	-	-	80	63	63	63	63	63	63	80	100	

Back-up gl/gG fuses only if  $I_{cs} > I_{cu}$  (kA)

Manual motor starter: GPS1...

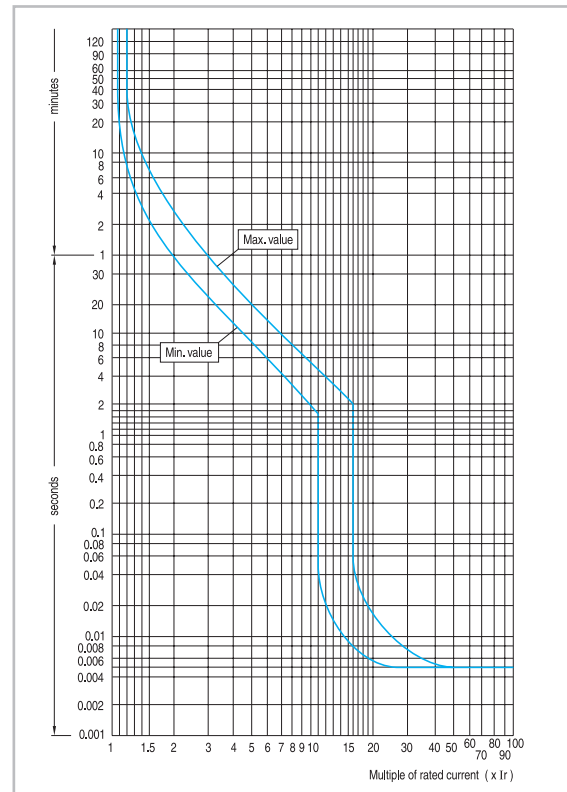

Manual motor starter: GPS2...

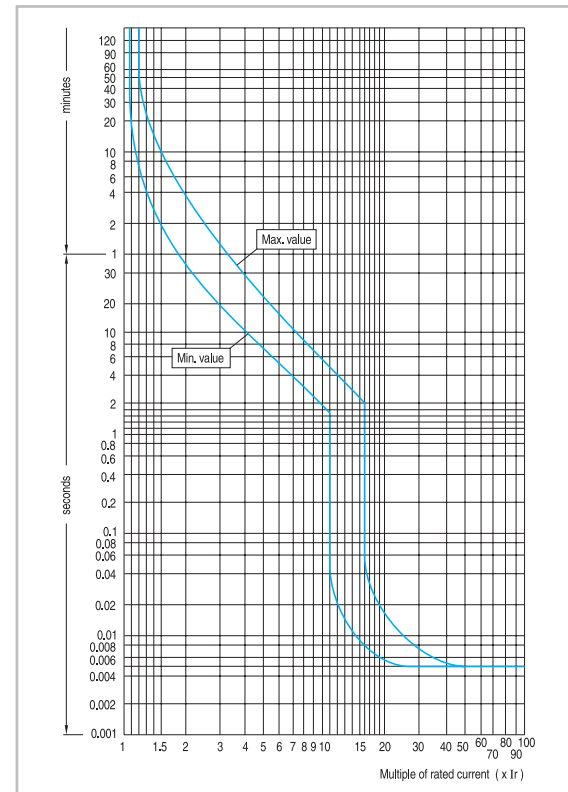



**Specific let-through energy at  $U_e = 400/415 V$**

Manual motor starter: GPS1...

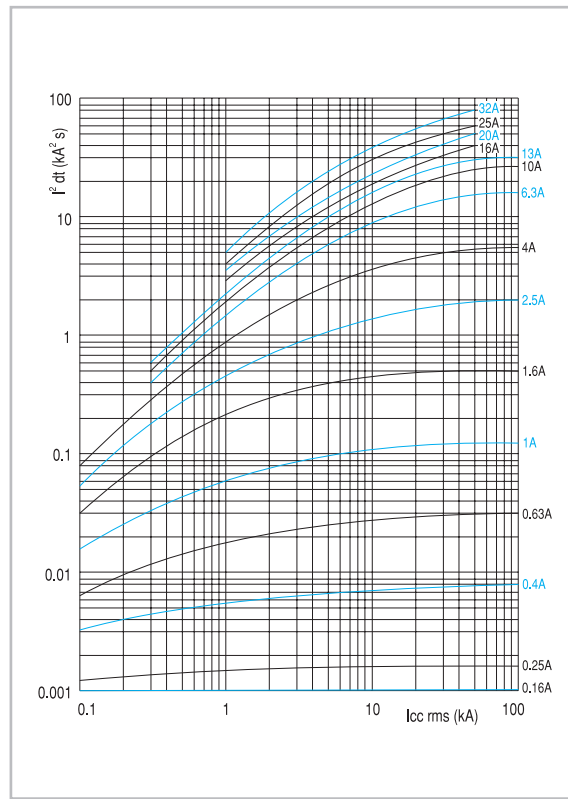

Manual motor starter: GPS2...

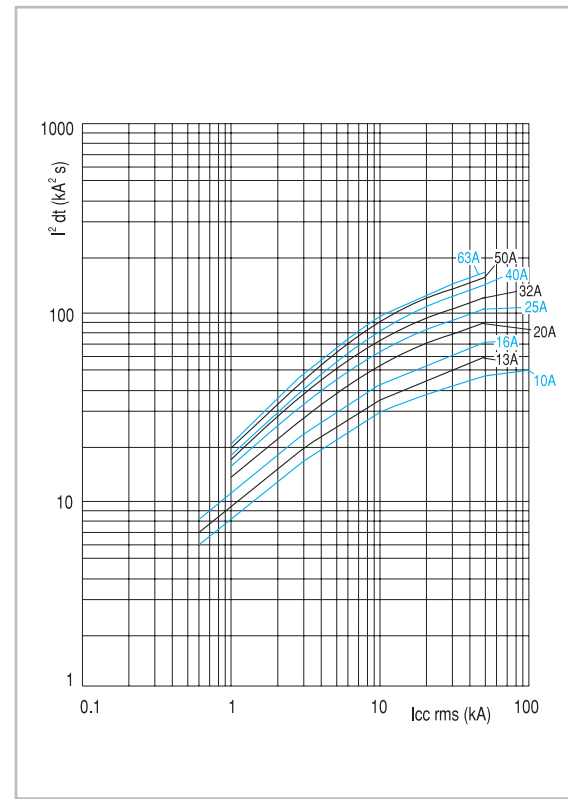

**Peak current limitation at  $U_e = 400/415 V$**

Manual motor starter: GPS1...

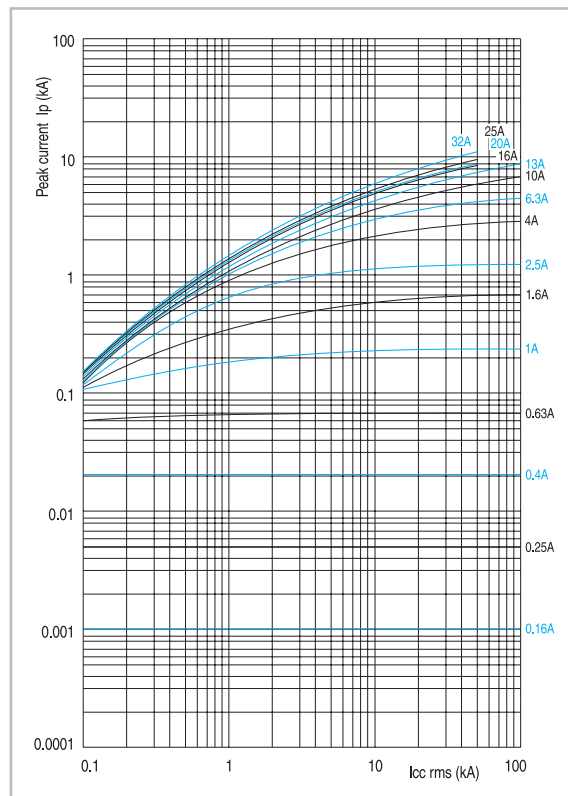

Manual motor starter: GPS2...

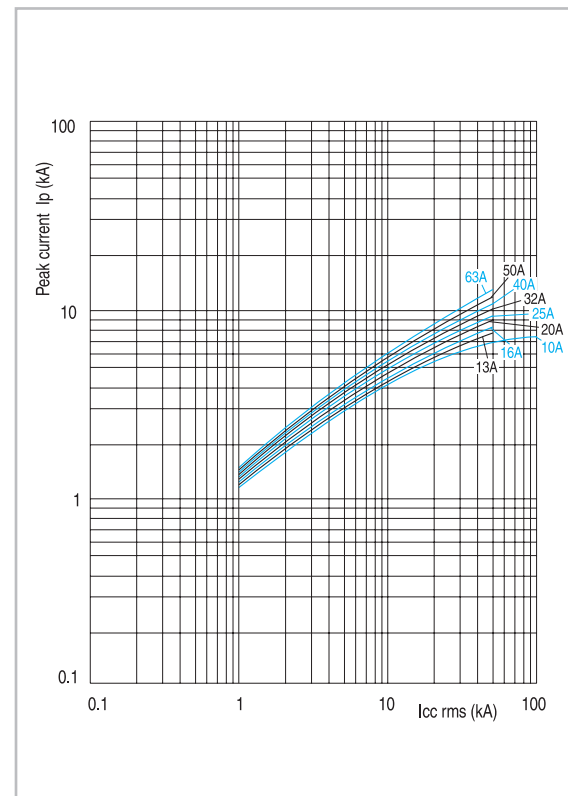

Technical data

Intro

A

B

**C**

D

E

F

G

H

I

J/X



Mounting possibilities of the auxiliaries

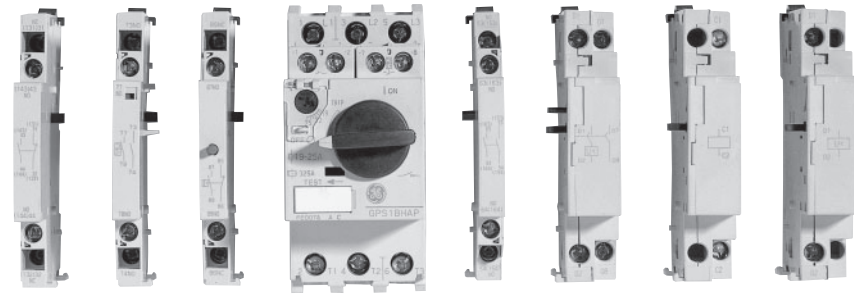

Wiring diagram	Type	Description
<p><b>Frontal auxiliaries</b></p>	Auxiliary contact block	1NO or 1NC
	Alarm contact block	1NO or 1NC
<p><b>Lateral auxiliaries</b></p>	Auxiliary contact block	2NO 1NO + 1NC 2NC
	Auxiliary/alarm contact block	1NO (alarm) + 1NO (auxiliary) 1NO (alarm) + 1NC (auxiliary) 1NC (alarm) + 1NO (auxiliary) 1NC (alarm) + 1NC (auxiliary)
	Short-circuit alarm contact block	1NO + 1NC
	Shunt trip	
	Undervoltage trip	
	Undervoltage trip with 2NO early make auxiliary contacts	

Shunt trip, undervoltage trip and undervoltage with 2NO contacts can be mounted together with any frontal block or left lateral block with above mentioned restrictions



Auxiliaries

Catalogue reference	GPAC*F..	GPAC*L..	GPAL..	GPAD..	GPAE..
	Aux. frontal block	Aux. lateral block	Alarm frontal block	Alarm/aux. lateral block	Short-circuit alarm block
Cont. cap. contacts class (UL508)	B300 / Q300	A600 / P300	B300 / Q300	A600 / P300	A600 / P300
Back-up fuses gG, gl	6A	10A	6A	10A	10A
Utilization category AC-15					
Rated operating voltage Ue (Vac)	48 125 230	48 125 230 400 500 690	48 125 230	48 125 230 400 500 690	48 125 230 400 500 690
Rated operational current (A)	5 3 1.5	6 4 4 2.2 1.5 0.6	5 3 1.5	6 4 4 2.2 1.5 0.6	6 4 4 2.2 1.5 0.6
Utilization category DC-13					
Rated operating voltage Ue (Vdc)	48 110 220	48 110 220	48 110 220	48 110 220	48 110 220
Rated operational current (A)	1.38 0.55 0.27	5 1.3 0.5	1.38 0.55 0.27	5 1.3 0.5	5 1.3 0.5
Mounting data					
Mounting side	Front	Left or right	Frontal right	Left	Left
Terminals capacity:					
Solid or stranded without end sleeve	2x0.5...2.5 mm <sup>2</sup>	2x0.5...2.5 mm <sup>2</sup>	2x0.5...2.5 mm <sup>2</sup>	2x0.5...2.5 mm <sup>2</sup>	2x0.5...2.5 mm <sup>2</sup>
AWG	2x18...14	2x18...14	2x18...14	2x18...14	2x18...14
Terminal type	screw	screw	screw	screw	screw
Tightening torque	0.8Nm	0.8Nm	0.8Nm	0.8Nm	0.8Nm
Screwdriver	Pz2/Slotted	Pz2/Slotted	Pz2/Slotted	Pz2/Slotted	Pz2/Slotted
Dimensions width (mm)	Maintain same width	Increase width 9 mm	Maintain same width	Increase width 9 mm	Increase width 9 mm

Catalogue reference	GPAU	GPAS
	Undervoltage trip	Shunt trip
Power consumption:		
Pick-up (VA/W)	21/12	21/12
Hold (VA/W)	8/1.2	-
Operating voltage		
Tripping (V)	0.35Ve-0.7Ve	0.7Ve-1.1Ve
Pick-up (V)	0.85Ve-1.1Ve	-
Max. operation supply (ms)	-	5(DC)
Rated operating voltage Ue	24V 50Hz 24V 60Hz 48V 50Hz 48V 60Hz 110/127V 50Hz / 120V 60Hz 208V 60Hz 220/230V 50Hz / 240/260V 60Hz 240V 50Hz / 277V 60Hz 380/400V 50Hz 415/440V 50Hz / 460/480V 60Hz 500V 50Hz / 600V 60Hz	24V 50/60Hz 48V 60Hz 48V 50Hz / 60V 60Hz 110/127V 50Hz / 120V 60Hz 208V 60Hz 220/230V 50Hz / 240/260V 60Hz 240V 50Hz / 277V 60Hz 380/400V 50Hz 415/440V 50Hz / 460/480V 60Hz 500V 50Hz / 600V 60Hz 24 to 60Vdc 110 to 240Vdc
Contacts class (UL508)	-	-
Back-up fuses (gG,gl)	10A	10A
Mounting data		
Mounting side	Right	Right
Terminals capacity:		
Solid or stranded without end sleeve	2x0.5...2.5 mm <sup>2</sup>	2x0.5...2.5 mm <sup>2</sup>
AWG	2x18...14	2x18...14
Terminal type	Screw	Screw
Tightening torque	0.8Nm	0.8Nm
Screwdriver	Pz2/Slotted	Pz2/Slotted
Dimensions width (mm)	Increase width 18 mm	Increase width 18 mm

Detailed dimensions see page C.25

Technical data

Intro

A

B

C

D

E

F

G

H

I

J/X



Dimensional drawings

Manual Motor Starter - GPS1 rocker

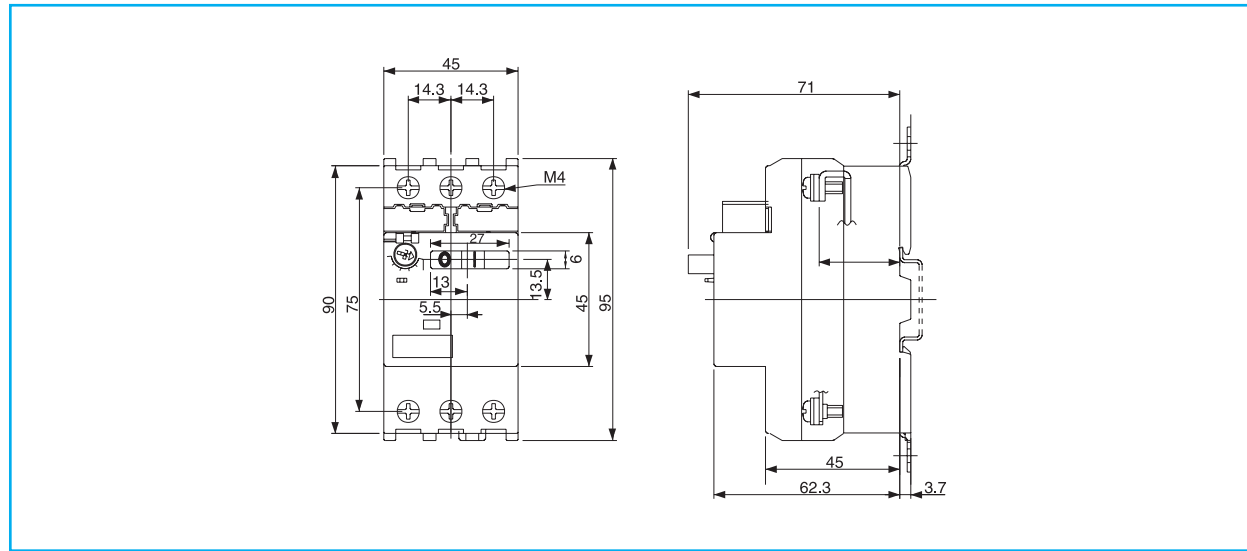

Manual Motor Starter - GPS1 rotary

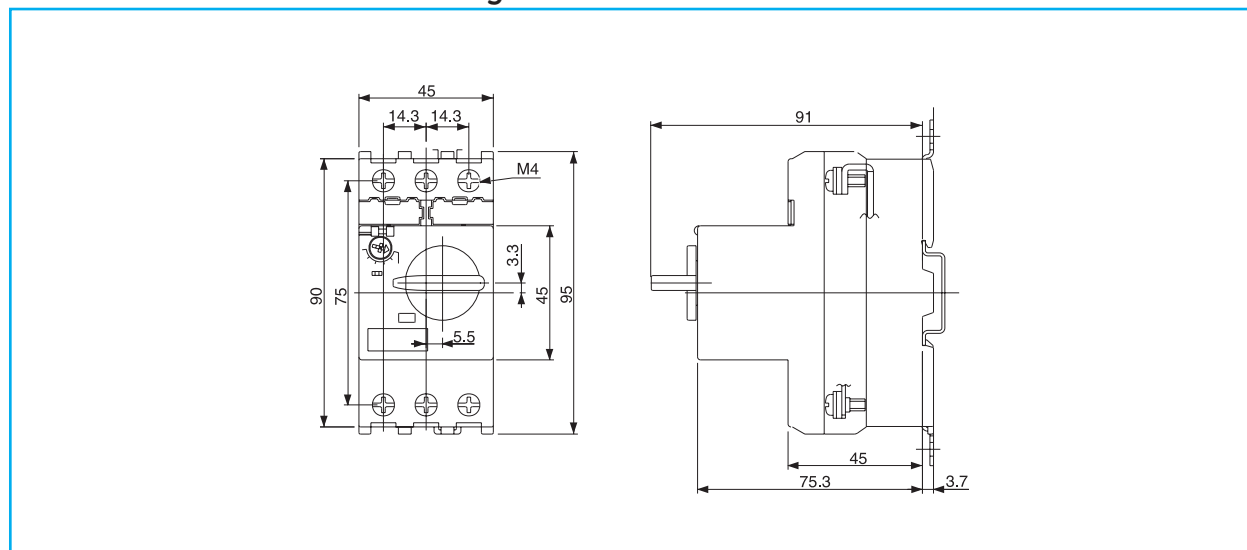

Manual Motor Starter - GPS2

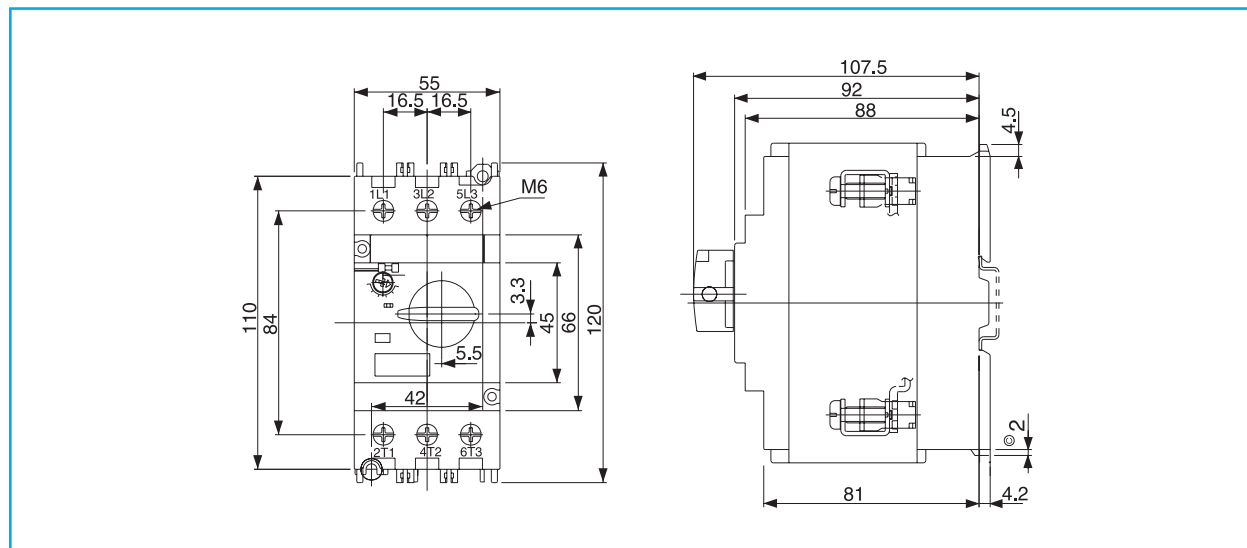

Auxiliary contact blocks

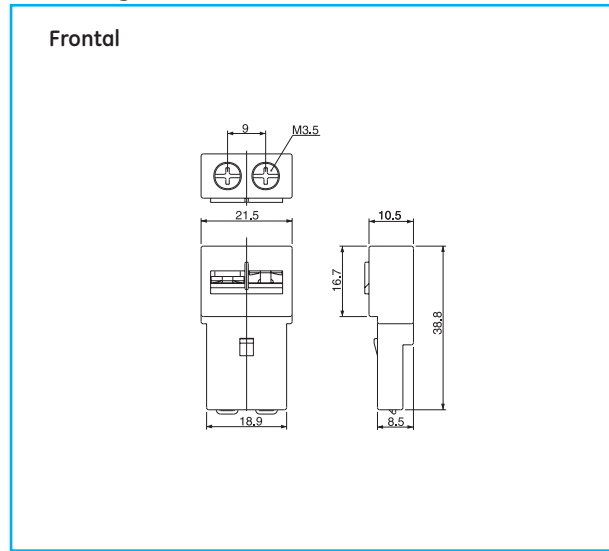

Auxiliary contact blocks

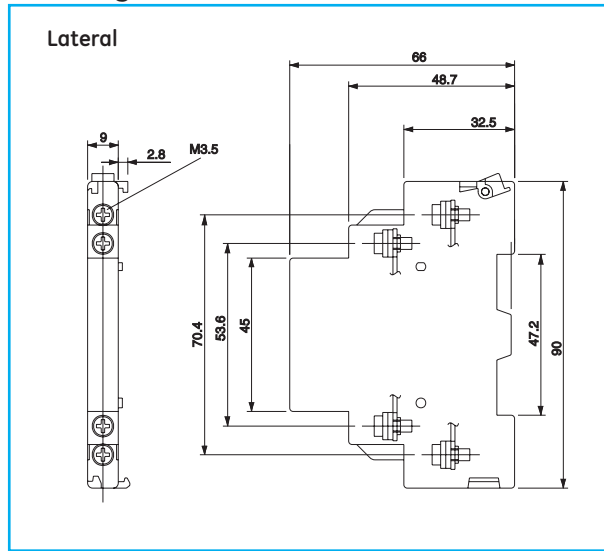

Alarm contact blocks

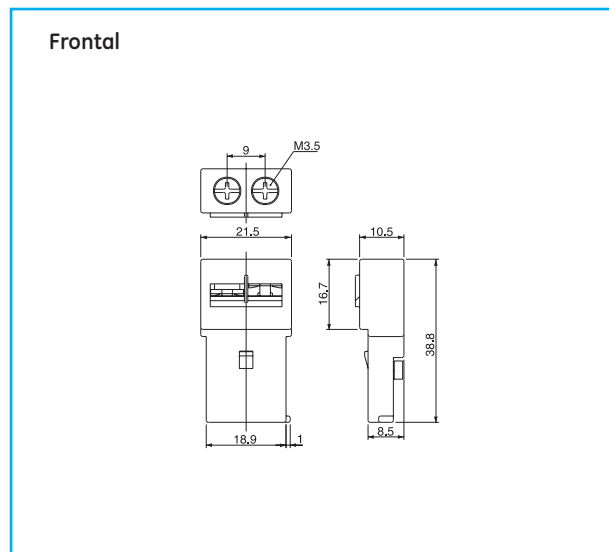

Alarm contact blocks

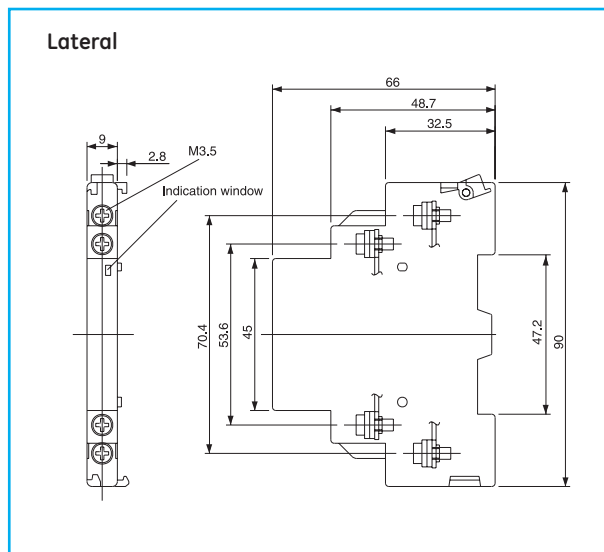

Shunt and undervoltage trip devices

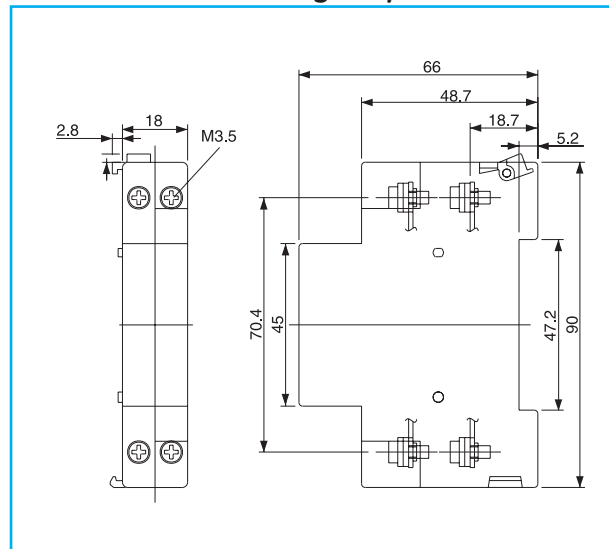

Short-circuit contact block

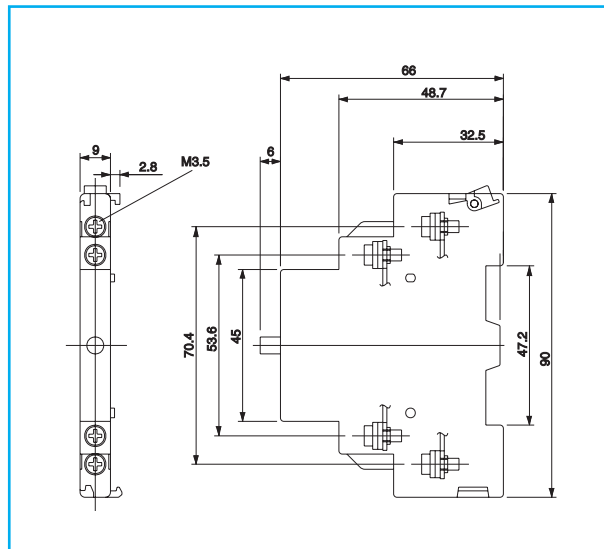

Dimensions

Intro

A

B

C

D

E

F

G

H

I

J/X



Dimensional drawings

GPS1 rocker + Undervoltage trip device with 2NO contacts

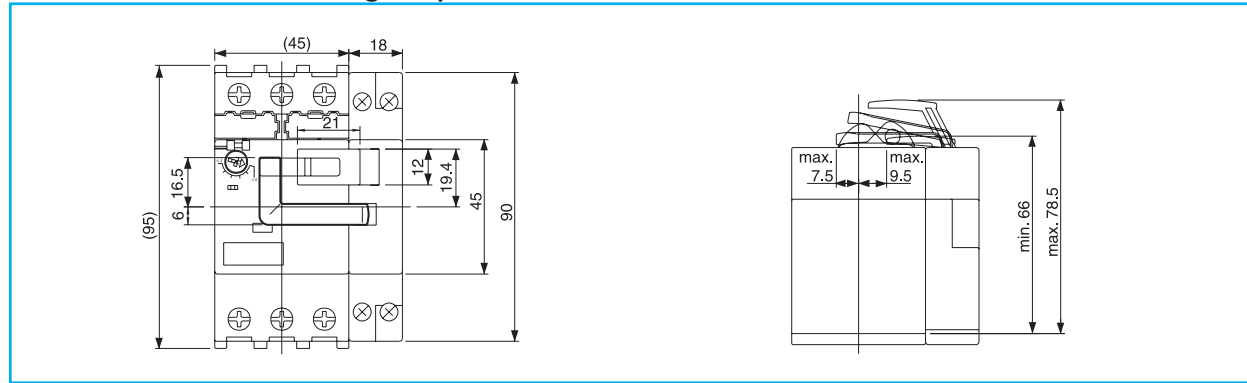

GPS1 rocker + Auxiliaries

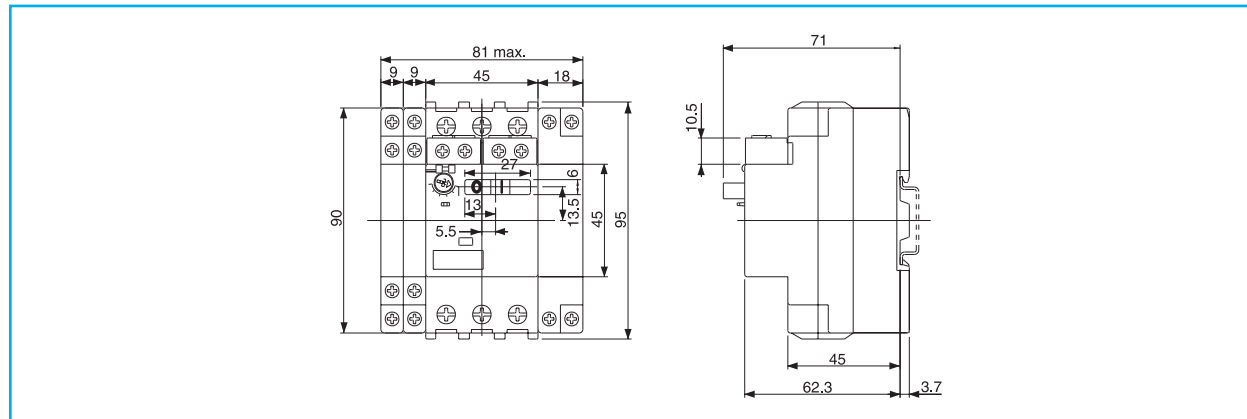

GPS1 rotary + Auxiliaries

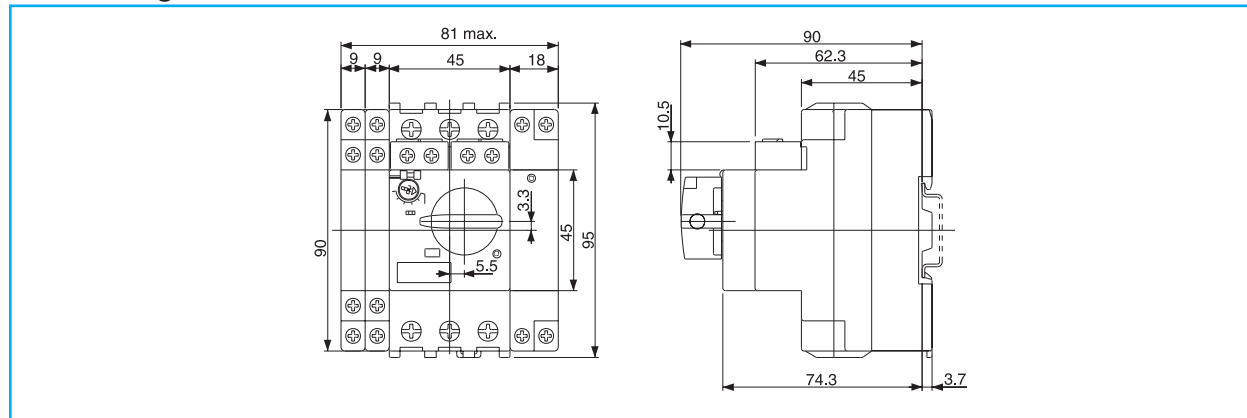

GPS2 + Auxiliaries

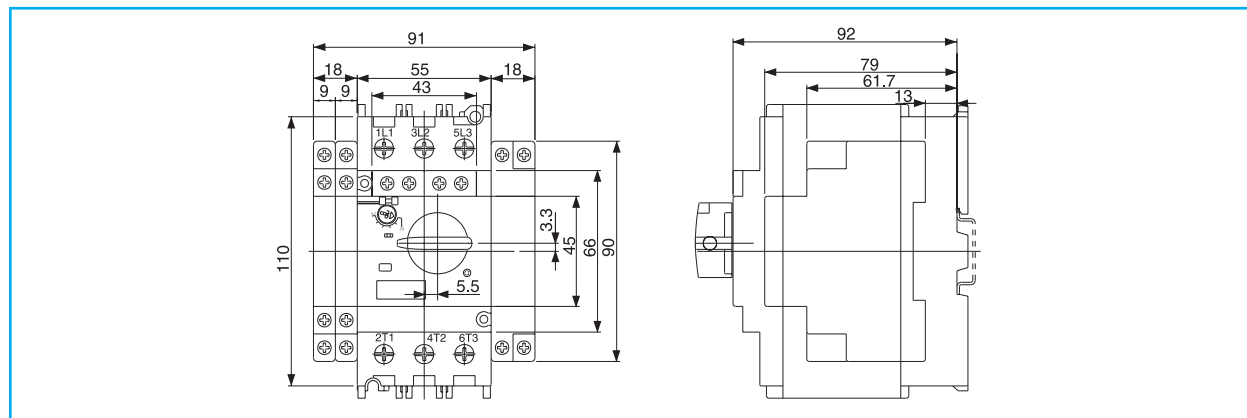

Motor protection devices  
Intro  
A  
B  
C  
D  
E  
F  
G  
H  
I  
J/X



External handle operator

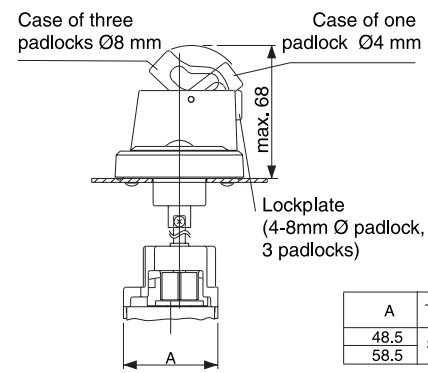
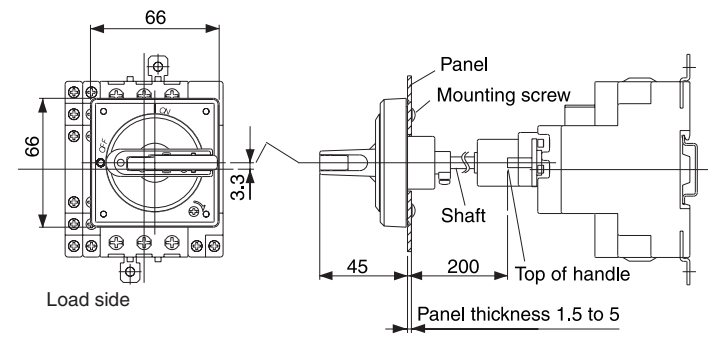

A	Type	Applicable frame
48.5	Standard / emergency stop	GPS1*H
58.5		GPS2

Dimensions

Intro

A

B

C

D

E

F

G

H

I

J/X



Dimensional drawings

Enclosure for GPS1 - Surface mounting

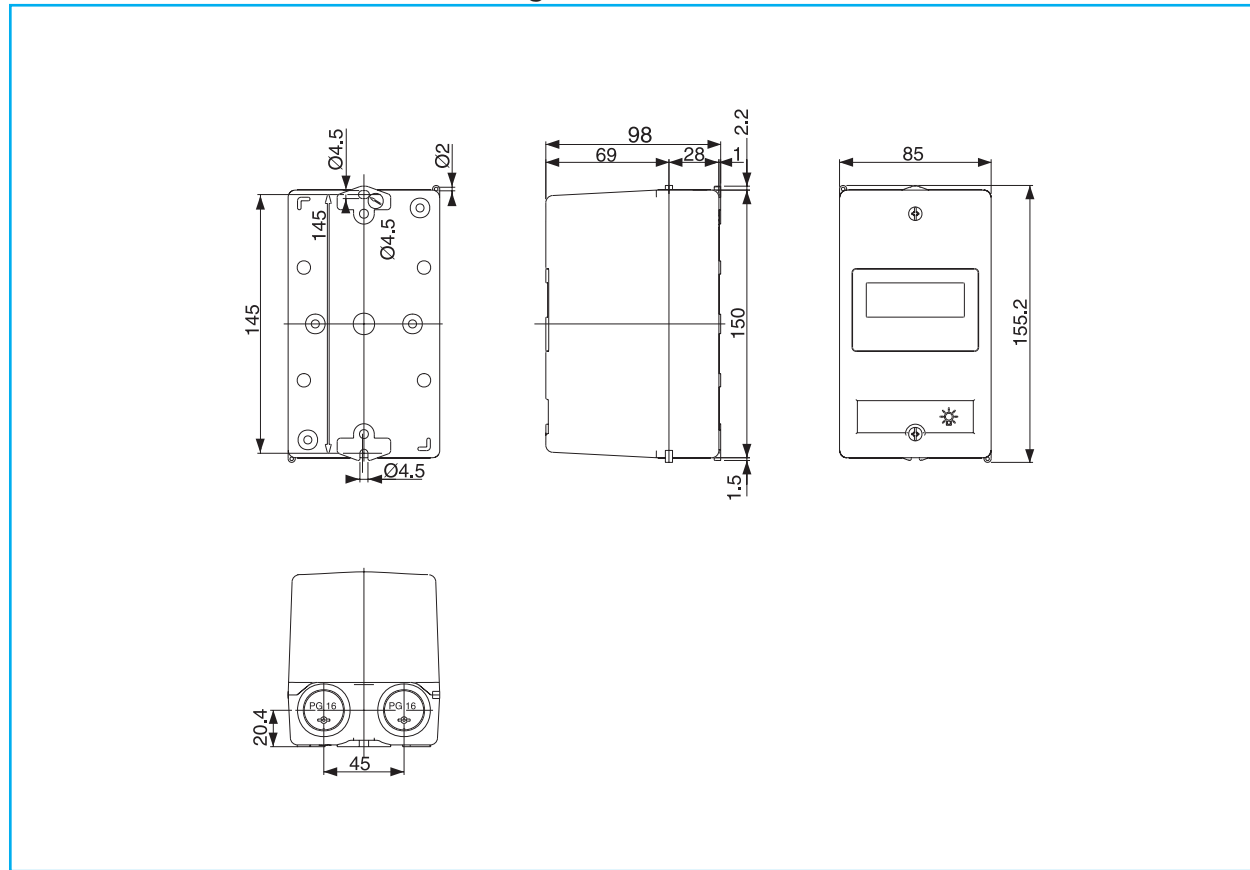

Enclosure for GPS1 - Surface mounting with padlocking device

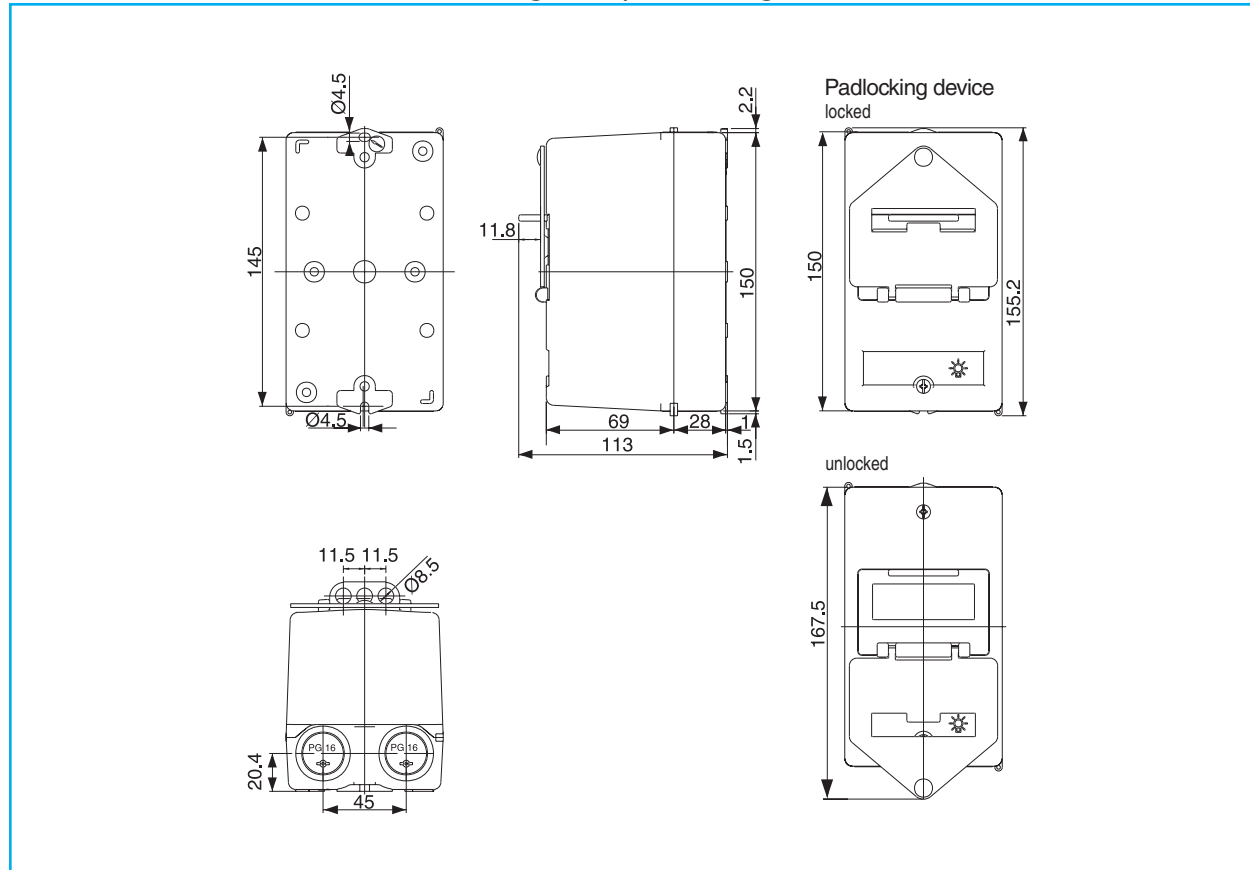





Enclosure for GPS1 - Surface mounting with emergency push-button

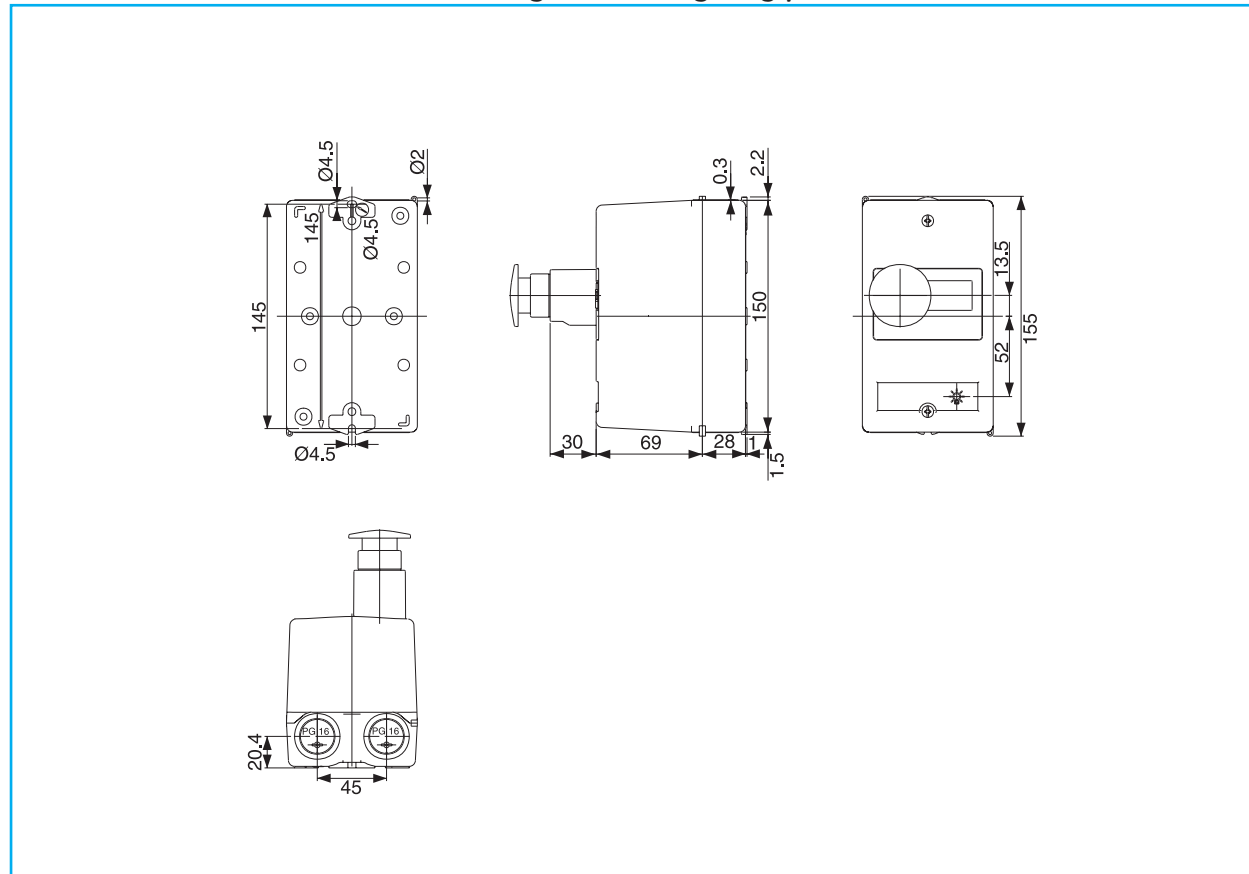

Dimensions

Intro

A

B

C

D

E

F

G

H

I

J/X



**Dimensional drawings**

**Enclosure for GPS1 - Flush mounting**

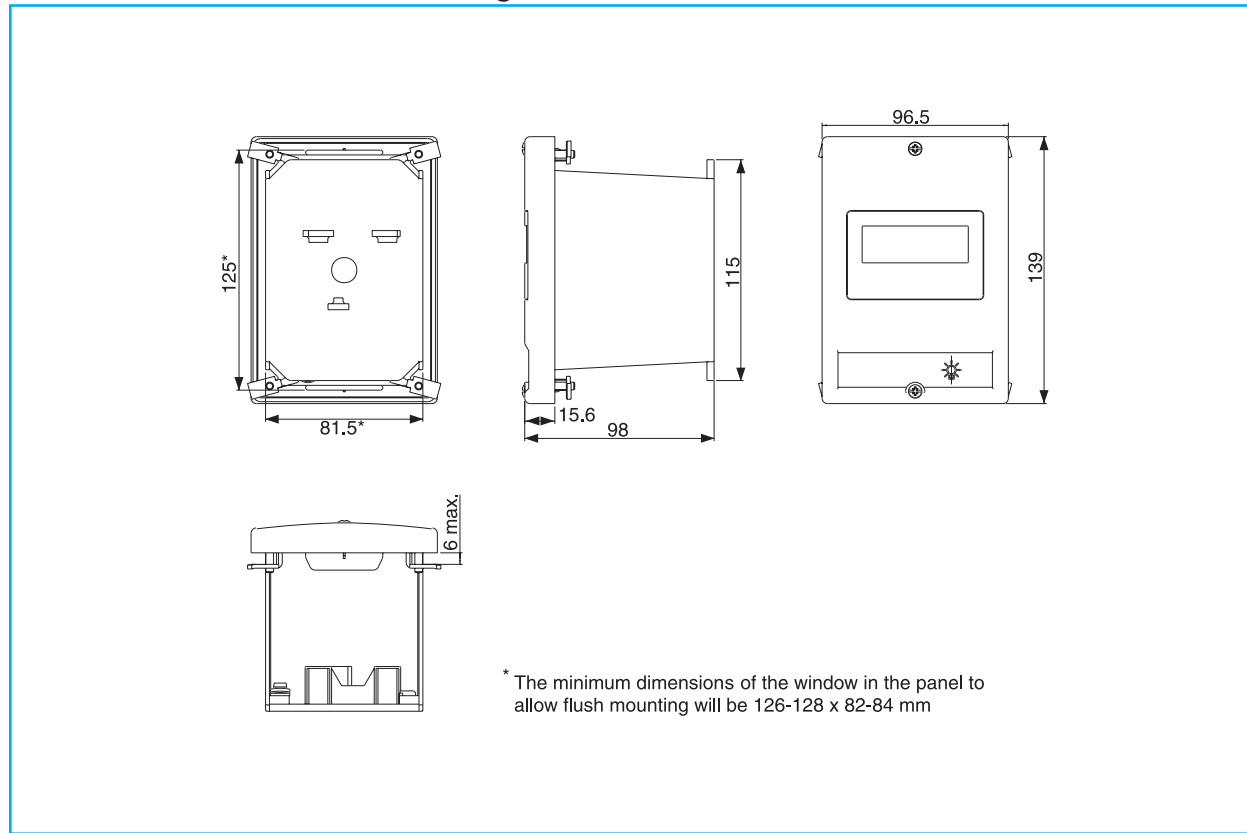

**Enclosure for GPS1 - Flush mounting with padlocking device**

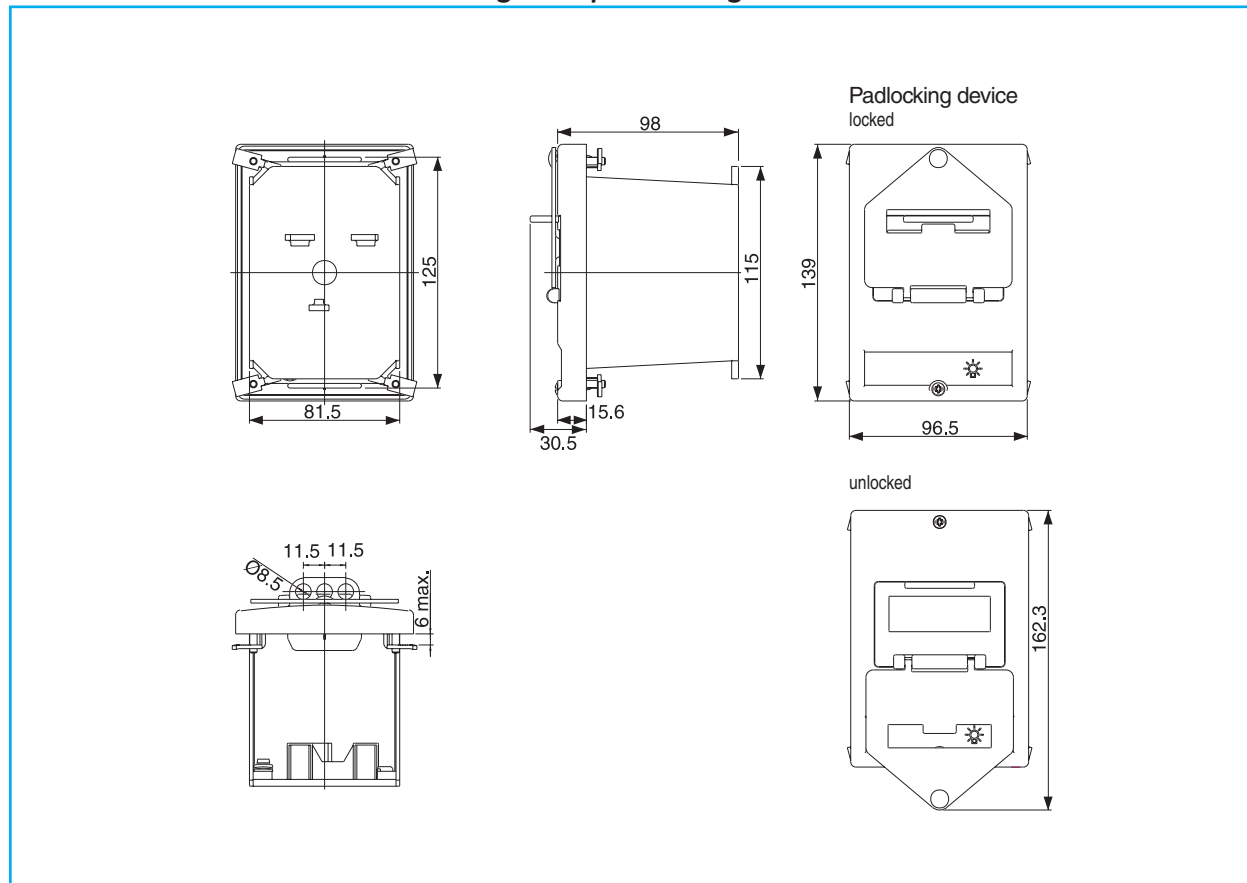

- Motor protection devices
- Intro
- A
- B
- C**
- D
- E
- F
- G
- H
- I
- J/X



Notes

Grid of dotted lines for notes.

Dimensions

Intro

A

B

C

D

E

F

G

H

I

J/X



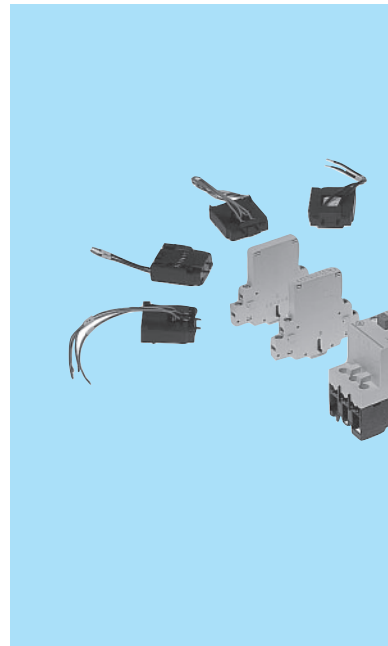

### Motor protection circuit breaker

- For thermal and magnetic protection of AC and DC motors
- Conformity to standards IEC 947-2, IEC 947-4-1 and VDE 0660
- Manual push-button operation
- Setting ranges from 0.1 to 25A at 690V AC and 220V DC
- Short-circuit capacity of 65kA up to setting range of 1.6-2.5A/400V

- Trip class 10
- Instant magnetic tripping (12 times the maximum operating current Ie)
- Single phase protection
- Ambient temperature compensation between - 5° C and + 40° C
- Internal and external accessories easy to mount
- Quick fixing on DIN rail EN 50022-35 and, with two screws, on plate or wall
- Terminals protected against accidental contacts (IP20)
- Suitable for isolation ( —|X ) and positive padlocking in open position (IEC 947-1 § 7-1-6)

#### Standards

IEC 947-2  
IEC 947-4-1  
VDE 0660

#### Approvals





### Motor protection circuit breakers





3-phase motor AC3 380/415V kW	Magnetical tripping current A	Thermal tripping current (setting range) A		Cat. no.	Ref. no.	Pack
		Min.	Max.			
0.02	1.9	0.1	0.16	SFKOA	120001	1/5
0.06	3.0	0.16	0.25	SFKOB	120002	1/5
0.06 / 0.09	4.8	0.25	0.4	SFKOC	120003	1/5
0.12 / 0.18	7.5	0.4	0.63	SFKOD	120004	1/5
0.25	12	0.63	1	SFKOE	120005	1/5
0.37 / 0.55	19	1	1.6	SFKOF	120006	1/5
0.75	30	1.6	2.5	SFKOG	120007	1/5
1.1 / 1.5	48	2.5	4	SFKOH	120008	5
2.2	75	4	6.3	SFKOI	120009	5
3.7 / 4.0	120	6.3	10	SFKOJ	120010	5
5.5 / 7.5	190	10	16	SFKOK	120011	5
9.0	240	16	20	SFKOL	120012	1/5
11 / 12.5	300	20	25	SFKOM	120013	1/5

Circuit breaker to protect transformers on request

**Auxiliary contact blocks**

				Cat. no.	Ref. no.	Pack
 <p>Side mounting</p>		1NO	1NC	SFAL11N	120020	5
		2NO		SFAL20N	120021	5
		1NO	1NC	SFAL11D	120022	5
		(advanced on closing)				
		2NO		SFAL20D	120023	5
		(advanced on closing)				
 <p>Internal mounting</p>		1NO	1NC	SFAI11	120024	5
	Switch trip indicator-alarm	1NO		SFAK10	120025	5
		1NC		SFAK01	120026	5
	For lower energy levels ( $\geq 4V, \geq 4mA$ )	1change-over PE + N conductor		SFAL11S	120027	1
				SFALPEN	264826	1

**Coils for internal mounting**

				Cat. no.	Ref. no.	Pack
 <p>Minimum power</p>	Functioning range: $0.35U_e < U < 0.7U_e$					
	Manual reset					
	Dissipated power 2.2VA / 1W					
		110V / 50Hz	120V / 60Hz	SFB0RJ	120034	5
	220V / 50Hz	240V / 60Hz	SFB0RN	120035	5	
	380V / 50Hz	440V / 60Hz	SFB0RU	120036	5	
 <p>Undervoltage release special for machinery</p>	According to IEC204-1, DIN VDE 0113, INRS Art. L233-5					
	A combination of a special undervoltage release and auxiliary contact block SFAL20D					
		110V / 50Hz	120V / 60Hz	SFB0RJM	107256	1
		220V / 50Hz	240V / 60Hz	SFB0RNM	120114	1
	380V / 50Hz	440V / 60Hz	SFB0RUM	120115	1	
 <p>Shunt trip</p>	Functioning range: $0.7U_e < U < 1.2U_e$					
	Manual reset					
		110V / 50Hz	120V / 60Hz	SFB0AJ	120030	5
		220V / 50Hz	240V / 60Hz	SFB0AN	120031	5
	380V / 50Hz	440V / 60Hz	SFB0AU	120032	5	

**Current limiter**

				Cat. no.	Ref. no.	Pack
 <p>Current limiter</p>	Combined with SFK.					
	Upgrades breaking capacity to 50kA/3~400V					
	Not available UL, CSA.					
	In = 32A			SFVH03	120050	1

Order codes

Intro

A

B

C

D

E

F

G



H

I





J/X



**Enclosures**

			Cat. no.	Ref. no.	Pack
 <p>Surface mounting</p>		IP41-PG16	SFS04	120040	1
		Conversion kit IP55	SFS0K2	120046	1
		IP55-PG16	SFS05	120041	1
		IP41-M25	SFS04M	212558	1
		IP65-M25	SFS05M	212559	1
 <p>Flush mounting</p>		IP41	SFE04	120042	1
		Conversion kit IP55	SFE0K2	120047	1
		IP55	SFE05	120043	1

**Accessories for enclosures**

			Cat. no.	Ref. no.	Pack
 <p>Neutral connection</p>	For use with surface and flush mounting enclosures		SFVNO	101369	1
 <p>Padlocking device</p>	Up to 3 padlocks 6 - 8 mm		SFVCD	120054	1
 <p>Emergency mushroom push-buttons IP55</p>	Impulse function	SFPS0	120051	1	
	Latched, pull to release	SFPRO	120052	1	
	Key locked, turn to release	SFPE0	120053	5	
	Conversion kit IP55 for SFS04	SFS04K1	245217	1	
	Conversion kit IP55 for SFE04	SFE04K1	216604	1	
 <p>Indicator lamps for AC and DC</p>	Green 110/120V	GPELGAJ	101375	1	
	Green 220/240V	GPELGAN	101376	1	
	Green 380/440V	GPELGAU	101377	1	
	Green 480/500V	GPELGAX	101378	1	
	Green 600V	GPELGAY	101379	1	
	Red 110/120V	GPELRAJ	101380	1	
	Red 220/240V	GPELRAN	101381	1	
	Red 380/440V	GPELRAU	101382	1	
	Red 480/500V	GPELRAX	101383	1	
	Red 600V	GPELRAY	101384	1	
	Transparent 110/120V	GPELCAJ	101385	1	
	Transparent 220/240V	GPELCAN	101386	1	
	Transparent 380/440V	GPELCAU	101387	1	
	Transparent 480/500V	GPELCAX	101388	1	
Transparent 600V	GPELCAV	101389	1		

Continued on page C.35



Accessories for enclosures (continued)

				Cat. no.	Ref. no.	Pack
Three phase busbar block	4 units	Ui 690V / Ie 63A	L = 207mm	GPB104A	101392	2
	5 units	Ui 690V / Ie 63A	L = 261mm	GPB105A	101393	2
	Plastic cover for 3 unused terminals			GPB1GA	101408	2
Supply block	Ie = 63A Fully insulated			SFVB8	254537	5

Terminal numbering

Motor protection circuit breaker

SFK...

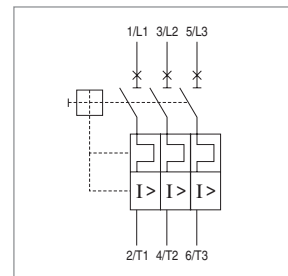

Auxiliary contact blocks

Side mounting

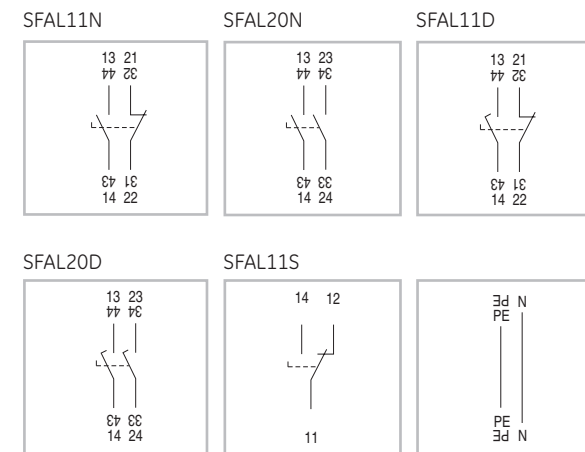

Internal mounting

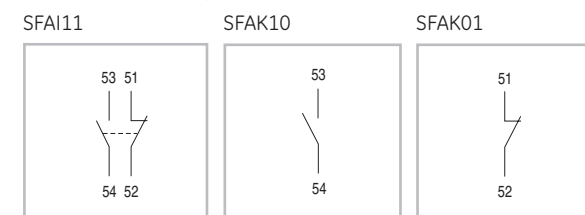

Order codes

Intro

A

B

C

D

E

F

G

H

I

J/X



Technical data

General

Rated thermal current (Ith) at 40°C	25A
Rated insulation voltage (Ui)	690V
Rated operational voltage (Ue) AC	690V, 40/60Hz
[see application diagram] DC	220V, with or without earth

Standards

IEC 947-2	IEC 947-4-1	VDE 0660
-----------	-------------	----------

Approvals

UL	CSA
----	-----

Main circuit

Category	AC3, DC4
Operational frequency limits	40 to 60 Hz
Opening time	approx. 7 ms
Mechanical endurance	10 <sup>5</sup> operations
Electrical endurance category AC3	10 <sup>5</sup> operations
Maximum operating rate	40 operations/hour
Total dissipated power at rated thermal current and hot state	6 W

Tripping characteristics

Thermal	
Symmetrical overloads	Class 10 (see curve 1, tripping curves)
Asymmetrical overloads (phase failure)	To IEC 947-4-1 (see curve 2, tripping curves)
Temperature compensation	- 5 to + 40°C
Magnetic	
	12 x Ie (Ie = max. thermal setting value)

Shunt release	
Operating voltage limits	0.7 - 1.2 Ue 100% ED
Consumption	AC 1 W DC 0.85 - 1.1 Ue 100% ED

Undervoltage release	
Operating voltage limits	0.75 - 0.35 Ue
Breaking voltage limits	2.2 VA
Consumption	1 W

Wiring capacity	
Rigid wire	min. 2 wires of 0,75mm <sup>2</sup> max. 2 wires of 6mm <sup>2</sup>
Flexible wire	min. 2 wires of 0,75mm <sup>2</sup> max. 2 wires of 4mm <sup>2</sup>

Tripping curve

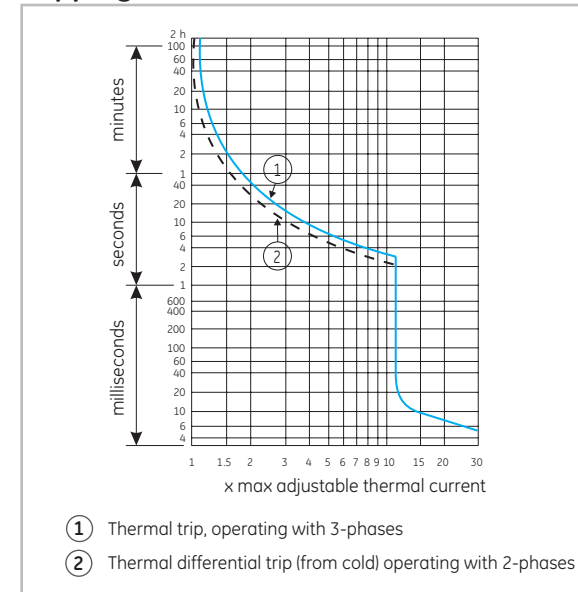

Mounting positions

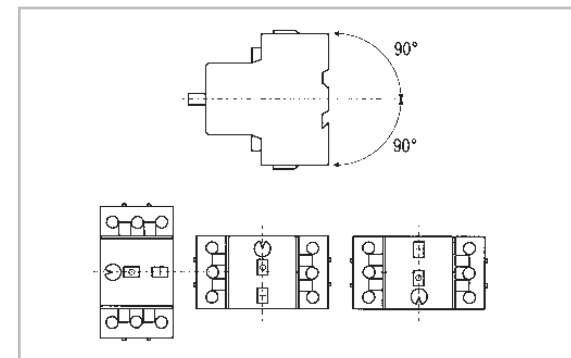

Auxiliary contact blocks

	SFAL	SFAI - SFAK
Rated insulation voltage (Ui) according VDE 0110	500V	500V
Rated thermal current (Ith)	6A	6A
AC-15	Ue 230V 400V 500V Ie 3,5A 2A 1A	230V 400V 500V 2A 1A 0,5A
DC-13	Ue 60V 110V 220V Ie 1,5A 1A 0,5A	60V 110V 220V 0,7A 0,55A 0,25A
Protective fuse gl	6A	6A
Wiring capacity		
Flexible wire	min. 2 x 0.75mm <sup>2</sup> max. 2 x 2.5mm <sup>2</sup>	2 x 0.75mm <sup>2</sup> 2 x 2.5mm <sup>2</sup>
Terminal type	M3,5, Pozidriv, safety flange screws	

Wiring diagram

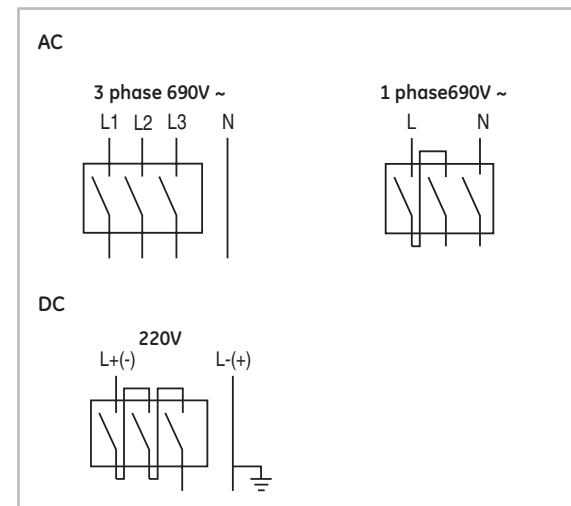

Application diagram for tooling machines

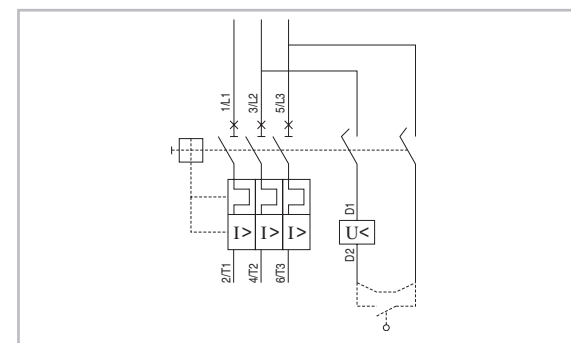



Short-circuit breaking capacity Icu/Ics according to IEC 947-2

Thermal adjustment (A)	230V AC / 220V DC <sup>(1)</sup>				400V AC				415V AC				500V AC				690V AC			
	3ph motor AC3 (kW)	Icu (kA)	Ics (kA)	Fuse <sup>(2)</sup> (A)	3ph motor AC3 (kW)	Icu (kA)	Ics (kA)	Fuse <sup>(2)</sup> (A)	3ph motor AC3 (kW)	Icu (kA)	Ics (kA)	Fuse <sup>(2)</sup> (A)	3ph motor AC3 (kW)	Icu (kA)	Ics (kA)	Fuse <sup>(2)</sup> (A)	3ph motor AC3 (kW)	Icu (kA)	Ics (kA)	Fuse <sup>(2)</sup> (A)
0.1 - 0.16	-	65	65	(3)	0.02	65	65	(3)	0.02	65	65	(3)	0.04	65	65	(3)	0.06	42	42	(3)
0.16 - 0.25	-	65	65	(3)	0.06	65	65	(3)	0.06	65	65	(3)	0.06	65	65	(3)	0.12	42	42	(3)
0.25 - 0.4	0.06	65	65	(3)	0.09	65	65	(3)	0.12	65	65	(3)	0.12	65	65	(3)	0.18	42	42	(3)
0.4 - 0.63	0.09	65	65	(3)	0.12	65	65	(3)	0.18	65	65	(3)	0.25	65	65	(3)	0.37	42	42	(3)
0.63 - 1	0.12	65	65	(3)	0.25	65	65	(3)	0.25	65	65	(3)	0.37	65	65	(3)	0.75	1	1	20
1 - 1.6	0.25	65	65	(3)	0.55	65	65	(3)	0.55	65	65	(3)	0.75	65	65	(3)	1.1	1	1	20
1.6 - 2.5	0.37	65	65	(3)	0.75	65	65	(3)	0.75	10	5	25	1.1	3	1.5	25	1.5	1	0.5	20
2.5 - 4	0.75	65	65	(3)	1.5	10 (4)	5 (4)	35	1.5	10	5	35	2.2	3	1.5	35	3	1	0.5	25
4 - 6.3	1.1	65	37.5(4)	(3)	2.2	10 (4)	5 (4)	50	2.2	10	5	50	3	3	1.5	50	4	1	0.5	35
6.3 - 10	2.2	10 (4)	5 (4)	80	4	4 (4)	2 (4)	80	4	4	2	80	5.5	3	1.5	50	7.5	1	0.5	35
10 - 16	4	6 (4)	3 (4)	80	7.5	4 (4)	2 (4)	80	7.5	3.5	1.75	80	9	3	1.5	63	11	1	0.5	35
16 - 20	5	6 (4)	3 (4)	80	9	4 (4)	2 (4)	80	9	2.5	1.25	80	11	1.5	0.75	63	15	1	0.5	50
20 - 25	5.5	6 (4)	3 (4)	80	11	4 (4)	2 (4)	80	12.5	2.5	1.25	80	15	1.5	0.75	63	22	1	0.5	50

Icu = Ultimate short-circuit breaking capacity  
Ics = Service short-circuit breaking capacity

- (1) At 220V, t = 15 ms
- (2) Maximum value of the fuses when the presumed short circuit current is higher than the breaking capacity of the device. Type D, slow or NH type gG/gL.
- (3) No back-up fuse required to the Icu value
- (4) 50 kA in combination with current limiter

Dimensional drawings

Motor protection circuit breaker

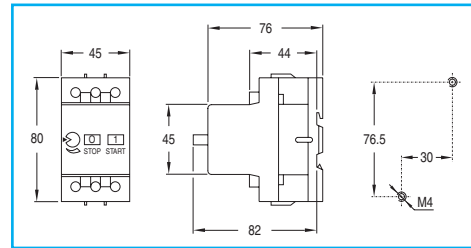

Auxiliary contact block Current limiter

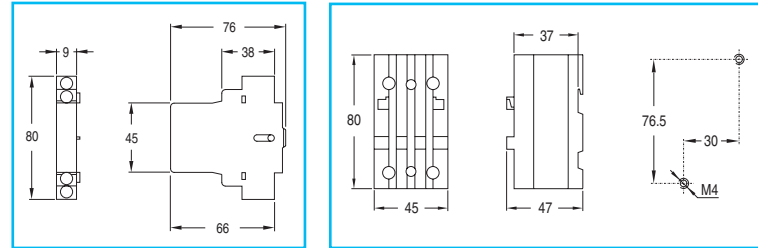

Enclosures: surface mounting

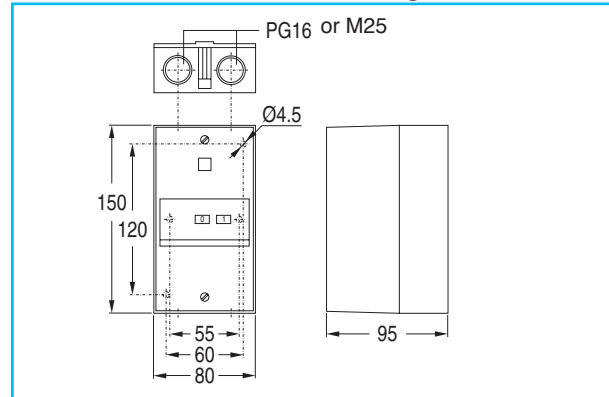

Enclosure to combine with contactor

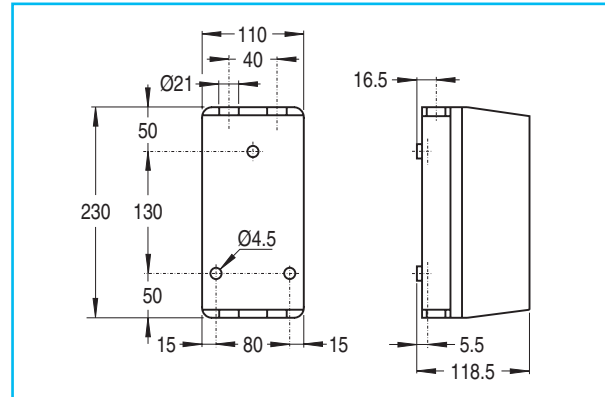

Enclosures: flush mounting

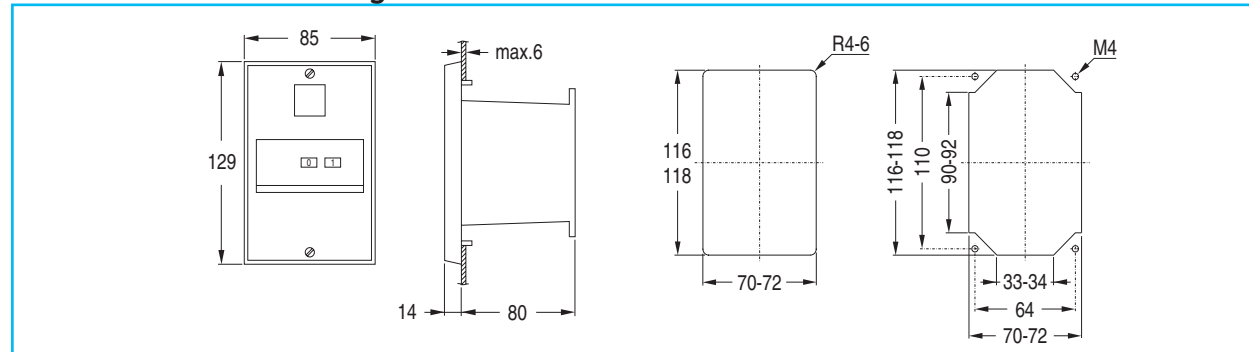

Technical data

Intro

A

B

C

D

E

F

G

H

I

J/X



Notes

Motor protection devices

Intro

A

B

C

D

E

F

G

H

I

J/X

Grid area for notes





- D.3 Utilization categories
- D.7 Electrical endurance
- D.8 Machine directive - B10d value for contactors

**Selection tables**

- D.9 Coordination tables
- D.18 Direct-on-line starters
- D.22 Star-delta starters
- D.26 Autotransformer starters
- D.28 Contactors for rotor starters
- D.30 Contactors for rotor speed drives
- D.32 Contactors for connection of power transformers
- D.33 Contactors for capacitors (category AC6b)
- D.34 Contactors for control lighting circuits
- D.36 Contactors for DC utilization

**POWER DEVICES**

Contactors and overload relays

Auxiliary relays and contactors

Motor protection devices

**Applications**

**D.38 Dimensional drawings** - Fuseless starters

Main switches

**D.42 Wiring diagrams**

**AUXILIARY DEVICES**

Control and signalling units

- D.42 Direc-on-line starters
- D.45 Star-delta starters
- D.46 Reversing starters
- D.48 Dimensional drawings starters

Electronic relays and limit switches

**POWER ELECTRONICS**

Speed drive units

Soft starters

Lighting dimmer-stabilizer/Numerical index

Intro
A
B
C
<b>D</b>
E
F
G
H
I
J/X



## Notes

A large grid of dotted lines for taking notes, spanning the width of the page and most of its height.



## Utilization categories according to IEC 60947-4-1

### Standard utilization categories AC

Category	Typical applications
AC-1	Non-inductive or slightly loads. Resistance furnaces
AC-2	Slip-ring motors: starting, plugging
AC-3	Squirrel-cage motors (1): starting, switching off motors during running.
AC-4	Squirrel-cage motors: starting, plugging, inching.
AC-5 a	Discharge lamps
AC-5 b	Incandescent lamps
AC-6 a	Transformers
AC-6 b	Cos φ capacitors
AC-7 a	Slightly inductive loads for domestic applications
AC-7 b	Motors in domestic applications
AC-8 a	Drive motors for cooling compressors (2) with manual reset and thermal overload relay
AC-8 b	Drive motors for cooling compressors (2) with manual reset and automatic reset

### Standard utilization categories DC

Category	Typical applications
DC-1	Non-inductive or slightly inductive loads. Resistance furnaces
DC-3	Shunt motors: starting, plugging, inching
DC-5	Series motors: starting, plugging, inching
DC-6	Incandescent lamps

## Making and breaking capacity

### IEC 60947-4-1

Values given for closing and opening by intermittent use

Cat.	Rated current	Closing (3)			Opening		
		Ic/Ie	Ur/Ue	cosφ(4)	Ic/Ie	Ur/Ue	cosφ(4)
AC-1	All values	1.5	1.05	0.80	1.5	1.05	0.80
AC-2	All values	4	1.05	0.65	4	1.05	0.65
AC-3	Ie ≤ 100A	10	1.05	0.45	8	1.05	0.45
	Ie > 100A	10	1.05	0.35	8	1.05	0.35
AC-4	Ie ≤ 100A	12	1.05	0.45	10	1.05	0.45
	Ie > 100A	12	1.05	0.35	10	1.05	0.35

Cat.	Rated current	Closing			Opening		
		Ic/Ie	Ur/Ue	L/R(5) (ms)	Ic/Ie	Ur/Ue	L/R(5) (ms)
DC-1	All values	1.5	1.05	1	1.5	1.05	1
DC-3	All values	4	1.05	2.5	4	1.05	2.5
DC-5	All values	4	1.05	15	4	1.05	15

## Electrical endurance

### IEC 60947-4-1

Values given for closing and opening intermittent use

Cat.	Rated current	Closing (3)			Opening		
		Ic/Ie	Ur/Ue	cosφ(4)	Ic/Ie	Ur/Ue	cosφ(4)
AC-1	All values	1	1	0.95	1	1	0.95
AC-2	All values	2.5	1	0.65	2.5	1	0.65
AC-3	Ie ≤ 17A	6	1	0.65	1	0.17	0.65
	Ie > 17A	6	1	0.35	1	0.17	0.35
AC-4	Ie ≤ 17A	6	1	0.65	6	1	0.65
	Ie > 17A	6	1	0.35	6	1	0.35

Cat.	Rated current	Closing			Opening		
		Ic/Ie	Ur/Ue (ms)	L/R(5)	Ic/Ie	Ur/Ue (ms)	L/R(5)
DC-1	All values	1	1	1	1	1	1
DC-3	All values	2.5	1	2	2.5	1	2
DC-5	All values	2.5	1	7.5	2.5	1	7.5

<b>Ue</b>	Rated voltage
<b>Ie</b>	Rated current
<b>Ur</b>	Recovery voltage
<b>Ic</b>	Breaking current

- (1) Category AC-3 can be used for accidental not continuous short period service, while mounting and testing machines. The number of operations shall not be greater than 5 per minute or 10 per 10 minutes.
- (2) The drive motor of a hermetic cooling compressor is an assembly of a motor and compressor in the same housing, without any axle; the motor is working in the cooling liquid.
- (3) Making conditions in alternating current are expressed by effective value. Moreover the asymmetrical current high value, referred to cos φ, can assume a higher value.
- (4) Tolerance for cos φ = ± 0.05
- (5) Tolerance for L/R = ± 15%

Utilization categories

Intro

A

B

C

D

E

F

G

H

I

J/X







Electrical endurance

Category AC1

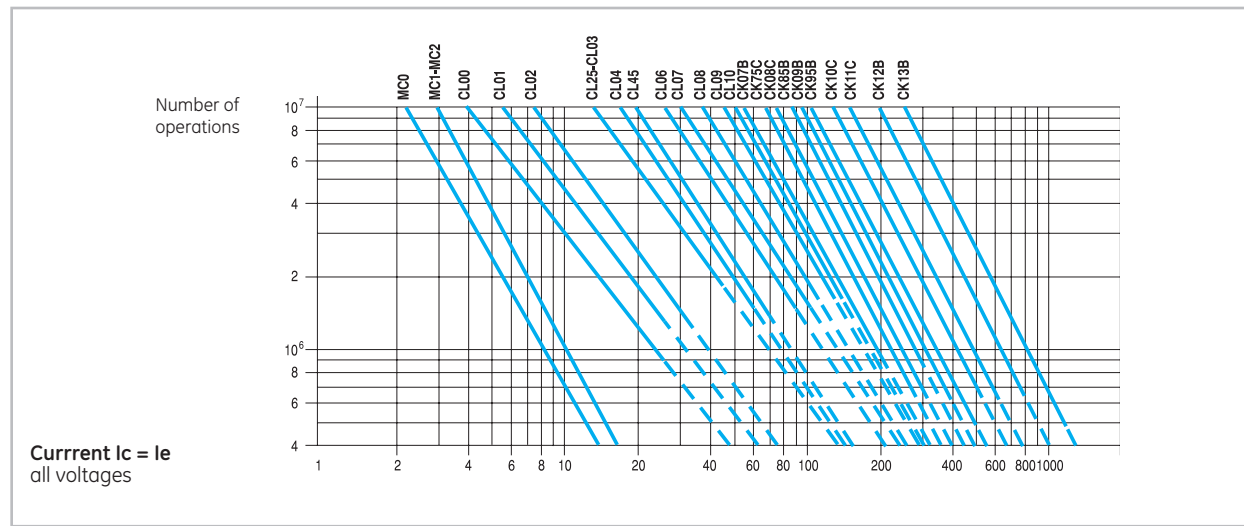

Category AC2

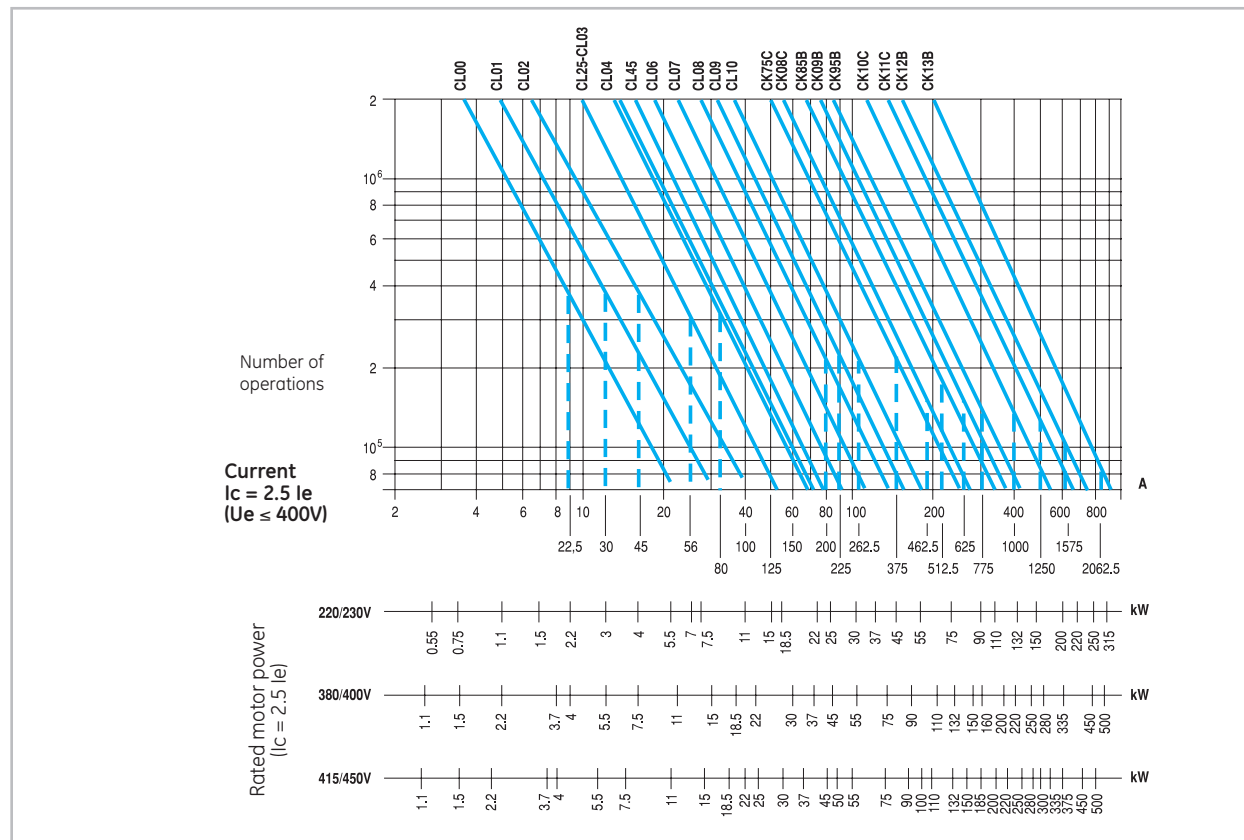



Category AC3

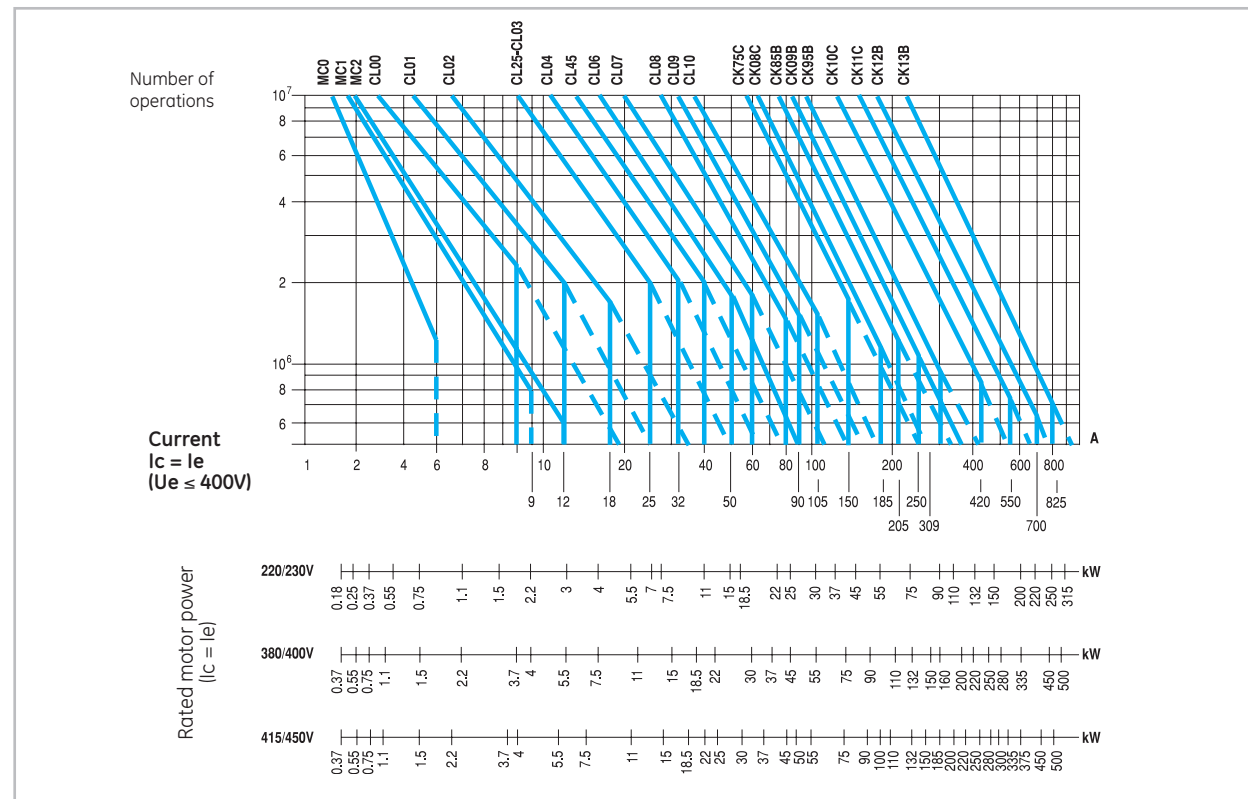

Category AC4

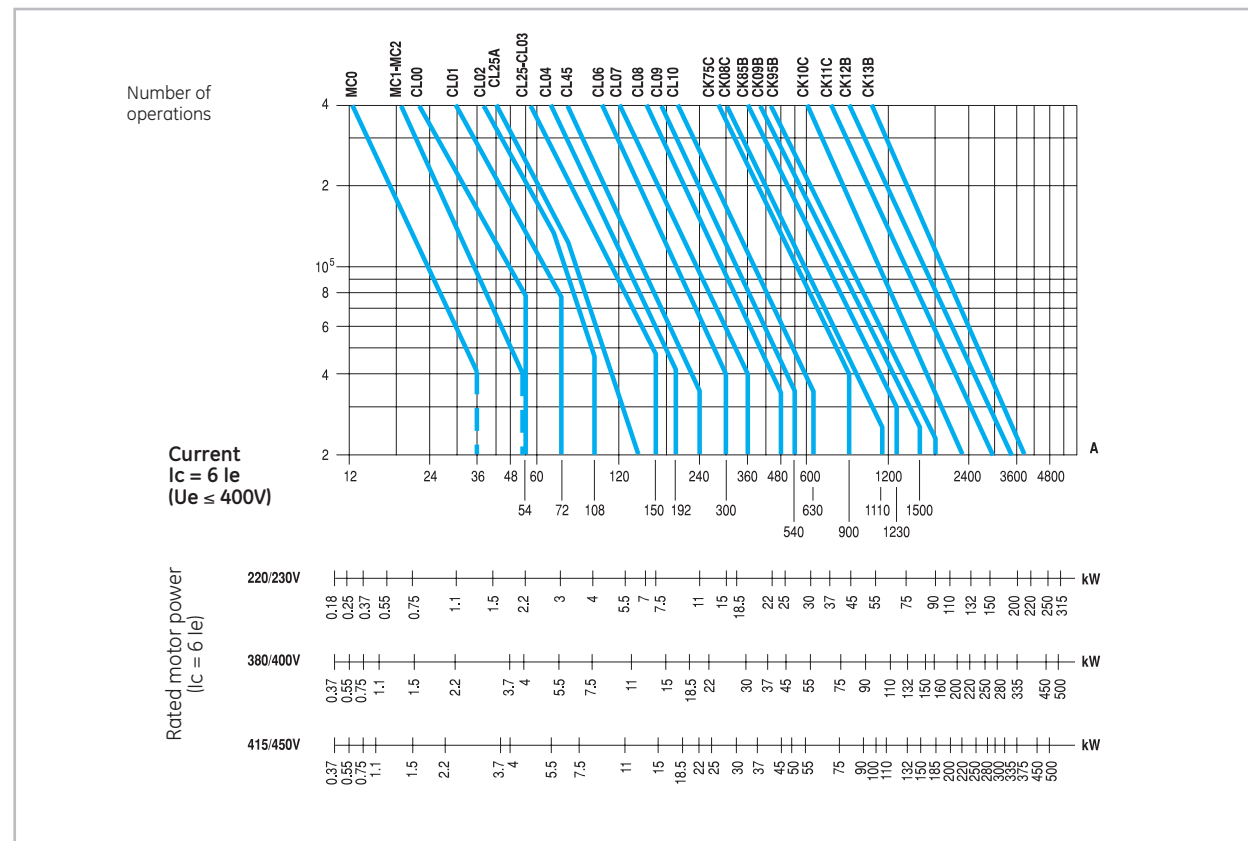

Electrical endurance

- Intro
- A
- B
- C
- D**
- E
- F
- G
- H
- I
- J/X



## B10d value for contactors

### According to ISO 13849-1

This part of ISO 13849 provides safety requirements and guidance on the principles for the design and integration of safety-related parts of control systems (SRP/CS), including the design of software. For these parts of SRP/CS, it specifies characteristics that include the performance level required for carrying out safety functions. It applies to SRP/CS, regardless of the type of technology and energy used (electrical, hydraulic, pneumatic, mechanical, etc.), for all kinds of machinery.

#### Terms and definitions

**Fault:** State of an item characterized by the inability to perform a required function, excluding the inability during preventive maintenance or other planned actions, or due to lack of external resources.

**Failure:** Termination of the ability of an item to perform a required function.

**Dangerous failure:** Failure which has the potential to put the SRP/CS in a hazardous or fail-to-function state

**B10d:** Number of cycles until 10 % of the components fails dangerously (for pneumatic and electromechanical components).

**Confidence level:** Statistical measure of the number of times out of 100 that test results can be expected to be within a specified range.

#### Calculations

Standard B10 values at a high demand rate. With the help of the B10 value and a simplified formula (see section 6.7.8.2.1 of EN 62061), the user can then calculate the total failure rate of an electromechanical component:

$$\lambda = 0.1 \times C / B10$$

With C = operating cycles per hour. C is specified by the user. The failure rate is made up of safe ( $\lambda_S$ ) and dangerous ( $\lambda_D$ ) failures:

$$\lambda = \lambda_S + \lambda_D \text{ or:}$$

$$\lambda_D = (\text{share of dangerous failures in \%}) \times \lambda$$

The failure rate of the dangerous failures  $\lambda_D$  of the components used is needed for further calculations.

$$\lambda_D = 50\% \text{ (value recommended by ISO 13849-1)}$$

$$\lambda_S = (\text{share of safe failures in \%}) \times \lambda$$

The failure rate of the safe failures  $\lambda_S$  of the components used is needed for further calculations.

$$\lambda_S = 10\%$$

CL = Confidence Level used for statistical calculations

Confidence Level used is needed for further calculations

$$CL = 60\%$$

Listed in the following table are the standard B10 and B10d values and the share of dangerous failures for products groups, where B10d is determinate as:

$$B10_d = B10$$

Share of dangerous failures

#### Test

Electrical endurance (AC3) test has been conducted to collect data which have been taken to calculate B10d value for MC, Efficor (EC) and CL contactors series.

For contactors dangerous failures rate has been calculated according to IEC 60947-5-1. ( $\lambda_D = 73\%$ ).

#### Results

	Contactors type	AC3 Current (A)	B10d (x10 <sup>6</sup> )
MC1	MC Series	9	1.4
EC09	Efficor	9	2.0
EC12	Efficor	12	2.0
EC18	Efficor	18	1.7
EC25	Efficor	25	1.7
EC32	Efficor	32	1.37
EC40	Efficor	40	1.37
CL06	CL Series	50	1.5
CL07	CL Series	65	1.5
CL08	CL Series	80	1.5
CL09	CL Series	95	1.5
CL10	CL Series	105	1.5



Technical data

Surion GPS-B: Coordination Type 1 65kA at 380/400V and 415V

Table with columns: MOTOR (1), MANUAL MOTOR STARTER, CONTACTOR, LINKS. Rows include Rated power (kW), Rated current (380/400V, 415V), Cat. no., Rated current In, Thermal current Setting range, Magnetic current, Series, Smallest wire Cu (PVC)(2), Minimum frontal electrical safety clearance, Cat. no. (3).

Surion GPS-B: Coordination Type 2 65kA at 380/400V and 415V

Table with columns: MOTOR (1), MANUAL MOTOR STARTER, CONTACTOR, LINKS. Rows include Rated power (kW), Rated current (380/400V, 415V), Cat. no., Rated current In, Thermal current Setting range, Magnetic current, Series, Smallest wire Cu (PVC)(2), Minimum frontal electrical safety clearance, Cat. no. (3).

(1) Currents are relevant to four pole motors not having special characteristics of torque. Inrush currents: 8 time rated current for 1s.

(2) The minimum cycle cross-sections are referred to an ambient temperature of 30°C max. in free air. Cables are to withstand the maximum let-through energy and the motor rated current. Besides the user should consider the drop voltage on the cables, the type of laying and the ambient temperature.

(3) Complete cat. nrs., see page D.3

(4) Test running.

Technical data

Intro

A

B

C

D

E

F

G

H

I

J/X



Surion GPS-B: Coordination Type 1 50kA at 500V and 525V

Table with 10 columns: MOTOR (1) (Rated power, Rated current), MANUAL MOTOR STARTER (Cat. no., Rated current In, Thermal current, Magnetic current), CONTACTOR (Series, Smallest wire Cu, Minimum frontal electrical safety clearance), LINKS (Cat. no. (3)).

Surion GPS-B: Coordination Type 2 50kA at 500V and 525V

Table with 10 columns: MOTOR (1) (Rated power, Rated current), MANUAL MOTOR STARTER (Cat. no., Rated current In, Thermal current, Magnetic current), CONTACTOR (Series, Smallest wire Cu, Minimum frontal electrical safety clearance), LINKS (Cat. no. (3)).

(1) Currents are relevant to four pole motors not having special characteristics of torque. Inrush currents: 8 time rated current for 1s.
(2) The minimum cycle cross-sections are referred to an ambient temperature of 30°C max. in free air. Cables are to withstand the maximum let-through energy and the motor rated current. Besides the user should consider the drop voltage on the cables, the type of laying and the ambient temperature.
(3) Complete cat. nrs., see page D.3





Surion GPS-B: Coordination Type 2 50kA at 380/400V and 415V

MOTOR (1)			MANUAL MOTOR STARTER				CONTACTOR			LINKS
Rated power (kW)	Rated current		Cat. no.	Rated current In (A)	Thermal current Setting range (A)	Magnetic current (A)	Series	Smallest wire Cu (PVC)(2) 380/415V (mm <sup>2</sup> )	Minimum frontal electrical safety clearance (mm)	Cat. no. (3)
	380/400V (A)	415V (A)								
0.06	0.23	0.21	GPS1BS/HAB	0.25	0.16 - 0.25	3.2	MC1 / CL00	1	20	GPF1LMCBA / GPF1L02*
0.09	0.34	0.31	GPS1BS/HAC	0.4	0.25 - 0.4	5.2	MC1 / CL00	1	20	GPF1LMCBA / GPF1L02*
0.12	0.44	0.4	GPS1BS/HAD	0.63	0.4 - 0.63	8.2	MC1 / CL00	1	20	GPF1LMCBA / GPF1L02*
0.18	0.65	0.63	GPS1BS/HAE	1	0.63 - 1	13	MC1 / CL00	1	20	GPF1LMCBA / GPF1L02*
0.25	0.9	0.8	GPS1BS/HAE	1	0.63 - 1	13	MC1 / CL00	1	20	GPF1LMCBA / GPF1L02*
0.37	1.25	1.1	GPS1BS/HAF	1.6	1 - 1.6	20.5	MC1 / CL00	1	20	GPF1LMCBA / GPF1L02*
0.55	1.6	1.5	GPS1BS/HAF	1.6	1 - 1.6	20.5	MC1 / CL00	1	20	GPF1LMCBA / GPF1L02*
0.75	2	1.9	GPS1BS/HAG	2.5	1.6 - 2.5	32.5	MC1 / CL00	1	20	GPF1LMCBA / GPF1L02*
1.1	2.6	2.5	GPS1BS/HAH	4	2.5 - 4	52	CL01	1	20	GPF1L02*
1.5	3.5	3.4	GPS1BS/HAH	4	2.5 - 4	52	CL01	1	20	GPF1L02*
2.2	5	4.5	GPS1BS/HAJ	6.3	4 - 6.3	82	CL02	1	20	GPF1L02*
3	7	6.5	GPS1BS/HAK	10	6.3 - 10	130	CL25	1.5	20	GPF1L25*
4	9	8	GPS1BS/HAK	10	6.3 - 10	130	CL25	1.5	20	GPF1L25*
5.5	12	11	GPS1BHAL	13	9 - 13	169	CL25	2.5	20	GPF1L25*
7.5	16	14	GPS1BHAM	16	11 - 16	208	CL25	2.5	20	GPF1L25*
11	22.5	21	GPS1BHAP	25	19 - 25	325	CL25	4	20	GPF1L25*
15	30	28	GPS1BHAR	32	24 - 32	416	CL04	6	20	GPF1L04*
11	22.5	21	GPS2BHAP	25	19 - 25	325	CL04	4	20	GPF2L04*
15	30	28	GPS2BHAR	32	24 - 32	416	CL04	6	20	GPF2L04*
18.5	37	35	GPS2BHAS	40	28 - 40	520	CL45	10	20	GPF2L45*
22	44	41	GPS2BHAT	50	35 - 50	650	CL06	10	25	GPF2L07*
30	60	55	GPS2BHAU	63	45 - 63	820	CL07	16	25	GPF2L07*

- (1) Currents are relevant to four pole motors not having special characteristics of torque.  
Inrush currents: ≤ 8 time rated current for ≤ 1s.
- (2) The minimum cycle cross-sections are referred to an ambient temperature of 30°C max. in free air. Cables are to withstand the maximum let-through energy and the motor rated current. Besides the user should consider the drop voltage on the cables, the type of laying and the ambient temperature.
- (3) Complete cat. nrs., see page D.3

Coordination tables

Intro

A

B

C

D

E

F

G

H

I

J/X





Surion GPS-M and Record Plus MCCBs: Coordination Type 1 50kA at 500 and 525V

Table with 12 columns: MOTOR (I), BREAKER, CONTACTOR, OVERLOAD RELAY, and safety parameters. Rows include motor ratings (0.06 to 55 kW) and corresponding breaker/relay settings.

Surion GPS-M and Record Plus MCCBs: Coordination Type 2 50kA at 500 and 525V

Table with 12 columns: MOTOR (I), BREAKER, CONTACTOR, OVERLOAD RELAY, and safety parameters. Rows include motor ratings (0.06 to 55 kW) and corresponding breaker/relay settings.





## Surion GPS-B and Record Plus MCCBs: Coordination Type 2 65kA at 380/400V and 415V

Rated power (kW)	MOTOR		MOTOR PROTECTION CIRCUITBREAKER			CONTACTOR	THERMAL RELAY
	I <sub>e</sub> 380/400V (A)	I <sub>e</sub> 415V (A)	Cat. no.	Setting range I <sub>n</sub> (A)	Magnetic setting I <sub>m</sub> (A)	Series (A)	Class 10
0.25	0.9	0.8	GPS1BHAE	0.63-1	13	CL00	Integrated into the motor protection circuit breaker
0.37	1.25	1.1	GPS1BHAF	1-1.6	20.5	CL00	Integrated into the motor protection circuit breaker
0.55	1.6	1.5	GPS1BHAF	1-1.6	20.5	CL00	Integrated into the motor protection circuit breaker
0.75	2	1.9	GPS1BHAG	1.6-2.5	32.5	CL00	Integrated into the motor protection circuit breaker
1.1	2.6	2.5	GPS1BHAH	2.5-4	52	CL25	Integrated into the motor protection circuit breaker
1.5	3.5	3.45	GPS1BHAH	2.5-4	52	CL25	Integrated into the motor protection circuit breaker
2.2	5	4.7	GPS1BHAJ	4-6.3	82	CL25	Integrated into the motor protection circuit breaker
3	7	6.5	GPS1BHAK	6.3-10	130	CL25	Integrated into the motor protection circuit breaker
4	9	8	GPS1BHAK	6.3-10	130	CL25	Integrated into the motor protection circuit breaker
5.5	12	11	GPS1BHAL	9.0-13	169	CL25	Integrated into the motor protection circuit breaker
7.5	16	14	GPS1BHAM	11.0-16	208	CL25	Integrated into the motor protection circuit breaker
11	22.5	21	GPS1BHAP	19-25	325	CL25	Integrated into the motor protection circuit breaker
15	30	28	GPS1BHAR	24-32	416	CL04	Integrated into the motor protection circuit breaker
18.5	37	35	GPS2BHAS	28-40	520	CL45	Integrated into the motor protection circuit breaker
22	44	41	GPS2BHAT	25-50	650	CL06	Integrated into the motor protection circuit breaker
30	60	55	GPS2BHAU	45-63	820	CL07	Integrated into the motor protection circuit breaker
37	72.5	65	FDH36MC080	80	950	CL08	RT2J (64-82A)
45	85	79	FDH36MC100	100	1140	CL09	RT2L (78-97A)

## Surion GPS-B and Record Plus MCCBs: Coordination Type 2 80kA at 380/400V and 415V

Rated power (kW)	MOTOR		MOTOR PROTECTION CIRCUITBREAKER			CONTACTOR	THERMAL RELAY
	I <sub>e</sub> 380/400V (A)	I <sub>e</sub> 415V (A)	Cat. no.	Setting range I <sub>n</sub> (A)	Magnetic setting I <sub>m</sub> (A)	Series (A)	Class 10
0.25	0.9	0.8	GPS1BHAE	0.63-1	13	CL00	Integrated into the motor protection circuit breaker
0.37	1.25	1.1	GPS1BHAF	1-1.6	20.5	CL00	Integrated into the motor protection circuit breaker
0.55	1.6	1.5	GPS1BHAF	1-1.6	20.5	CL00	Integrated into the motor protection circuit breaker
0.75	2	1.9	GPS1BHAG	1.6-2.5	32.5	CL00	Integrated into the motor protection circuit breaker
1.1	2.6	2.5	GPS1BHAH	2.5-4	52	CL25	Integrated into the motor protection circuit breaker
1.5	3.5	3.45	GPS1BHAH	2.5-4	52	CL25	Integrated into the motor protection circuit breaker
2.2	5	4.7	GPS1BHAJ	4-6.3	82	CL25	Integrated into the motor protection circuit breaker
3	7	6.5	GPS1BHAK	6.3-10	130	CL25	Integrated into the motor protection circuit breaker
4	9	8	GPS1BHAK	6.3-10	130	CL25	Integrated into the motor protection circuit breaker
5.5	12	11	GPS1BHAL	9.0-13	169	CL05	Integrated into the motor protection circuit breaker
7.5	16	14	FDH36MC020	20	210	CL04	RT1S (14.5-18A)
11	22.5	21	FDH36MC030	30	300	CL45	RT1U (21-26A)
15	30	28	FDH36MC030	30	450	CL45	RT1V (25-32A)
18.5	37	35	FDH36MC050	50	500	CL45	RT1W (30-40A)
22	44	41	FDH36MC050	50	580	CL06	RT2G (42-55A)
30	66	55	FDH36MC080	80	800	CL07	RT2H (54-65A)
37	72.5	65	FDH36MC080	80	950	CL08	RT2J (64-82A)
45	85	79	FDH36MC100	100	1140	CL09	RT2L (78-97A)

(1) Current are relevant to four pole motors not having special characteristics of torque. Inrush currents: ≤ 8 time rated current for ≤ 1s.

(2) The minimum cycle cross-sections are referred to an ambient temperature of 30°C max. in free air and are selected to withstand the maximum let-through energy and the motor rated current. Besides the user has to consider the drop voltage, the type of laying and ambient temperature.

Coordination tables

Intro

A

B

C

**D**

E

F

G

H

I

J/X



**Record Plus MCCBs: Coordination Type 2 150kA at 380/400V and 415V (Class 10 protection)**

MOTOR (1)			THERMAL-MAGNETIC CIRCUIT BREAKER				CONTACTOR			
Rated power (kW)	Rated current		Cat. no. (3)	Magnetic setting Im pick-up band ± 20% Im (A)	Magnetic current Setpoint (A)	Thermal setting range (A)	Thermal setpoint (400V) (A)	Series	Smallest wire Cu (PVC) (2) 380/415V (mm <sup>2</sup> )	Min frontal safety clearance (mm)
	380/400V (A)	415V								
7.5	16	14	FD*36TD016ED	160	160	12.8 - 16	16	CL45	2.5	20
11	22.5	21	FD*36TD025ED	250	250	20 - 25	22.5	CL45	4	20
15	30	28	FD*36TD032ED	320	320	26 - 32	30	CL45	6	20
18.5	37	35	FD*36TD040ED	400	400	32 - 40	37	CL45	10	20
22	44	40	FD*36TD050ED	500	500	40 - 50	40	CL06	10	25
30	60	55	FD*36TD063ED	630	630	50 - 63	55	CL07	16	25
37	72	68	FD*36TD080GD	800	800	64 - 80	68	CL08	25	25
45	85	80	FD*36TD100GD	1000	1000	80 - 100	80	CL09	35	30
55	105	100	FD*36TD125GD	1250	1250	100 - 125	100	CL10	35	30
75	138	135	FD*36TD160GD	1280	1280	128 - 160	135	CK75	50	40
90	170	165	FE*36TD200KF	1000 - 2000	1700	160 - 200	165	CK08	70	40
110	211	200	FE*36TD250KF	1250 - 2500	2100	200 - 250	200	CK85	95	40
132	245	240	FE*36TD250KF	1250 - 2500	2500	200 - 250	240	CK09	120	40

(\*) Max Iq rating in kA: type N = 50 kA, type H = 80 kA, type L = 150 kA.

(1) Current are relevant to four pole motors not having special characteristics of torque. Inrush currents: ≤ 8 times rated current for ≤ 1s (Normal starting) or H 5s (Heavy starting).

(2) The minimum cycle cross-sections are referred to an ambient temperature of 30°C max. in free air and are selected to withstand the maximum let-through energy and the motor rated current. Besides the user has to consider the drop voltage, the type of laying and ambient temperature.

(3) Foreseen values for E-frame.





## Direct-on-line starters

- Motors connected directly on-line with a contactor and a thermal overload relay.
- Simple installation with high starting torque and current.
- For use with motors of medium power that do not need a progressive star

AC-3	Switching off motors during running	$I_c = I_e$
AC-4	Switching off motors during starting	$I_c = 6 I_e$

Torque-speed curve

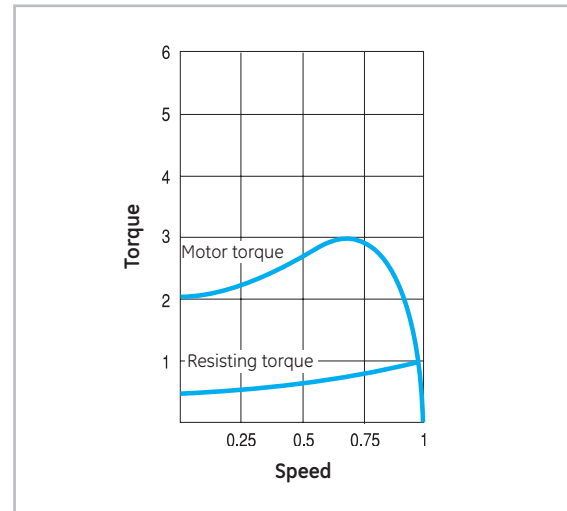

Current-speed curve

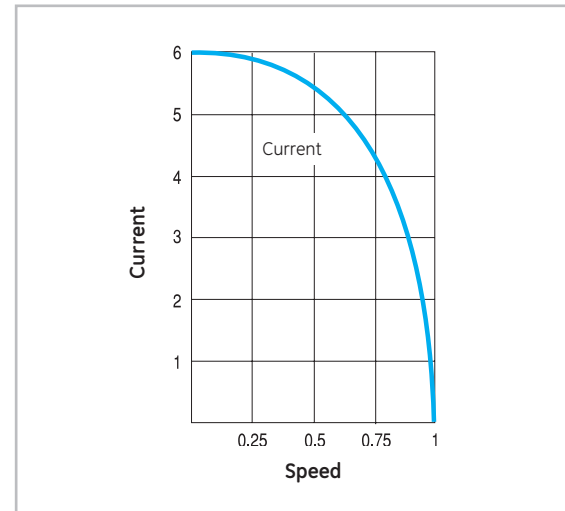

Diagram

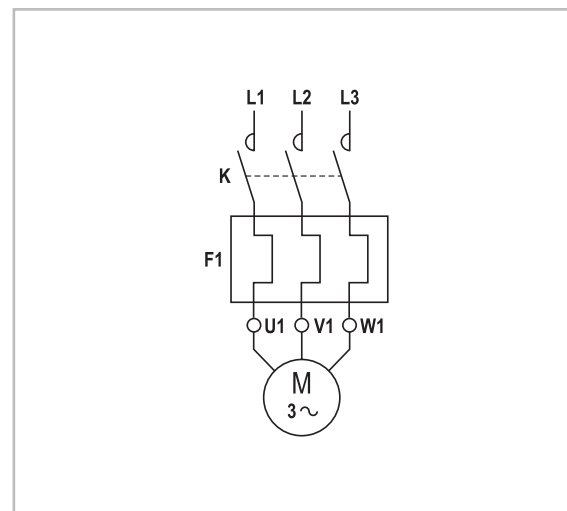





Selection table (continued 2)

Motor										Contactor	Thermal relay	Fuse		
230/200V		400/380V		440/415V		500V		690/660V				1000V		aM
kW	A	kW	A	kW	A	kW	A	kW	A	kW	A	A	A	
-	-	-	-	-	-	220	310	280	292	-	-	RT5C	400	425
-	-	-	-	185	325	-	-	300	307	-	-	RT5C	425	500
-	-	-	-	-	-	-	-	315	322	-	-	RT5C	425	500
110	356	185	355	200	350	250	348	335	344	-	-	RT5D	425	500
-	-	220	370	220	385	-	-	355	366	-	-	RT5D	500	500
-	-	-	-	-	-	280	385	375	390	-	-	RT5D	500	500
-	-	220	408	-	-	300	409	-	-	-	-	RT5D	500	500
-	-	-	-	-	-	-	-	-	-	280	197	RT5B	250	315
-	-	-	-	-	-	-	-	-	-	300	211	RT5B	315	355
-	-	-	-	-	-	-	-	-	-	315	221	RT5B	315	355
-	-	-	-	-	-	-	-	-	-	335	234	RT5B	315	355
-	-	-	-	-	-	-	-	-	-	355	245	RT5B	315	355
-	-	-	-	-	-	-	-	400	412	-	-	RT5D	500	500
132	425	-	-	250	437	315	426	-	-	-	-	RT5D	630	630
-	-	-	-	-	-	335	456	425	442	-	-	RT5D	630	630
-	-	250	475	280	480	355	485	450	462	-	-	RT5E	630	630
150	500	-	-	300	508	375	513	-	-	-	-	RT5E	630	630
160	520	280	530	315	530	400	543	-	-	-	-	RT5E	630	630
-	-	-	-	-	-	-	-	-	-	375	256	RT5B	315	355
-	-	-	-	-	-	-	-	-	-	400	273	RT5C	400	425
-	-	-	-	-	-	-	-	-	-	425	290	RT5C	400	425
-	-	-	-	-	-	-	-	-	-	450	307	RT5C	400	425
-	-	-	-	-	-	-	-	475	488	-	-	RT5E	630	630
-	-	-	-	-	-	-	-	500	514	-	-	RT5E	630	630
-	-	300	563	335	565	-	-	-	-	-	-	RT5E	630	630
185	609	315	580	355	600	-	-	-	-	-	-	RT5E	630	630
200	630	335	630	375	630	450	613	-	-	-	-	RT5E	800	800
220	710	355	650	-	-	475	647	-	-	-	-	RT5E	800	800
-	-	375	680	400	673	-	-	-	-	-	-	RT5E	800	800
-	-	-	-	-	-	-	-	-	-	475	324	RT5C	500	630
-	-	-	-	-	-	-	-	-	-	500	341	RT5C	500	630
-	-	-	-	-	-	500	680	-	-	-	-	RT6A	1000	1000
-	-	400	720	425	714	-	-	-	-	-	-	RT6A	1000	1000
-	-	425	763	450	756	-	-	-	-	-	-	RT6A	1000	1000
250	823	450	800	-	-	-	-	-	-	-	-	RT6A	1000	1000

Direct-on-line starters

- Intro
- A
- B
- C
- D
- E
- F
- G
- H
- I
- J/X



## Star-delta starters

### For AC squirrel cage motors

In order to use this type of starting, the following conditions must be met:  
 The ends of the three stator windings should terminate in a terminal box (6 terminals, see diagram).  
 The line voltage should be the same as the motor delta connection voltage.

This starting system is suitable for machines where the resisting torque during starting is less than 1/3 of the motor torque (see torque speed curves).  
 The target of this type of starting is to reduce the current during starting to 1/3, there by reducing the linedrop (see current speed curves).  
 Reduce the motor torque to 1/3 to smooth out mechanical stress on the machine and on the load (see torque speed curves).

### Torque-speed curve

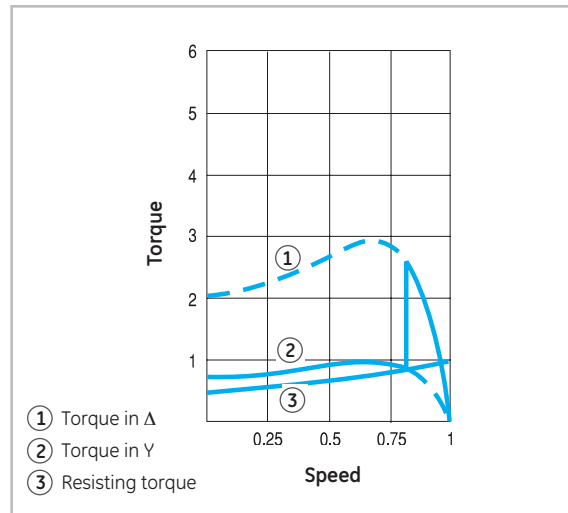

### Current-speed curve

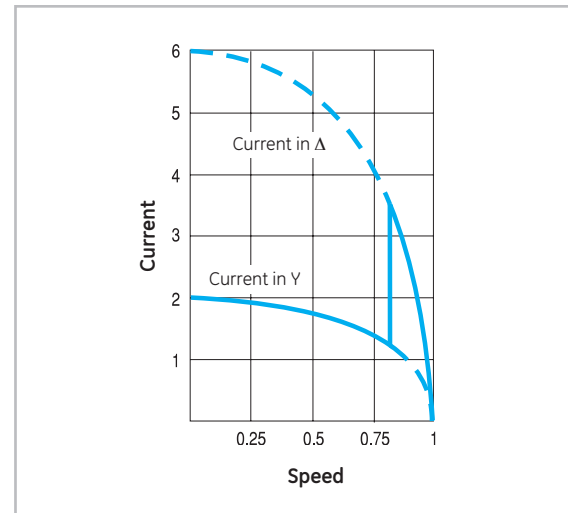

### Diagram

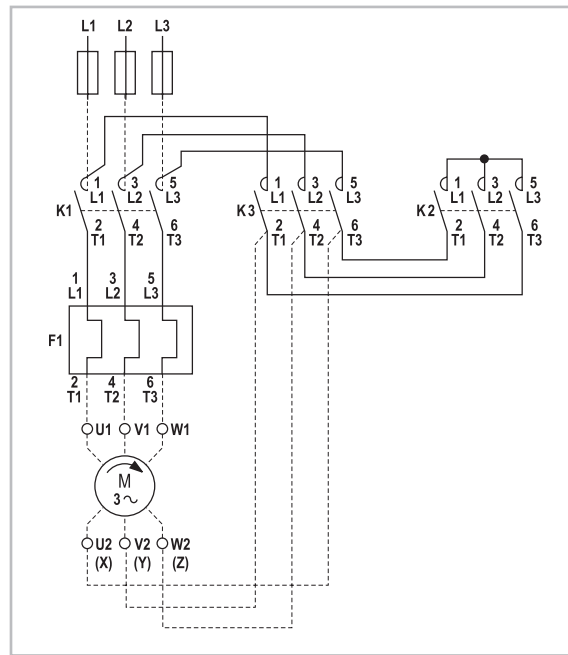







**Selection table (continued 2)**

Motor										Contactors		Thermal	Fuse			
230/200V		400/380V		440/415V		500V		690/660V		1000V		Line and Delta	Star	relay	aM	gG-gL
kW	A	kW	A	kW	A	kW	A	kW	A	kW	A				A	A
250	823	-	-	-	-	-	-	-	-	-	-	CK11C	CK10C	RT5E	1000	1000
-	-	-	-	-	-	-	-	-	-	630	428	CK11C	CK10C	RT5B	500	630
-	-	-	-	-	-	-	-	-	-	670	455	CK11C	CK10C	RT5C	500	630
-	-	450	800	-	-	-	-	-	-	-	-	CK11C	CK10C	RT5E	1000	1000
-	-	475	846	500	840	-	-	-	-	-	-	CK11C	CK10C	RT5E	1000	1000
-	-	-	-	-	-	-	-	800	821	-	-	CK11C	CK10C	RT5E	1000	1000
-	-	500	892	530	890	630	857	850	873	-	-	CK11C	CK10C	RT5E	1000	1000
280	910	530	943	560	941	670	912	-	-	-	-	CK11C	CK10C	RT5E	2x630	2x630
300	975	-	-	-	-	710	965	-	-	-	-	CK12C	CK10C	RT5E	2x630	2x630
315	1023	560	996	600	1010	750	1020	-	-	-	-	CK12C	CK10C	RT5E	2x630	2x630
335	1083	-	-	630	1058	-	-	-	-	-	-	CK12C	CK10C	RT5E	2x630	2x630
-	-	-	-	-	-	-	-	-	-	750	510	CK12C	CK11C	RT5C	630	630
-	-	-	-	-	-	-	-	900	924	-	-	CK13B	CK11C	RT6A	2x630	2x630
-	-	-	-	-	-	800	1088	950	975	-	-	CK13B	CK11C	RT6A	2x630	2x630
-	-	600	1074	-	-	-	-	-	-	-	-	CK12B	CK11C	RT5E	2x630	2x630
355	1142	-	-	710	1097	-	-	-	-	-	-	CK12B	CK11C	RT5E	2x630	2x630
-	-	-	-	-	-	-	-	-	-	800	543	CK13B	CK11C	RT5C	630	800
-	-	630	1128	670	1125	-	-	-	-	-	-	CK12B	CK11C	RT5E	2x630	2x630
375	1206	670	1200	710	1190	850	1156	-	-	-	-	CK13B	CK11C	RT6A	2x800	2x800
400	1286	710	1270	750	1255	-	-	-	-	-	-	CK13B	CK11C	RT6A	2x800	2x800
425	1364	-	-	-	-	-	-	-	-	-	-	CK13B	CK12C	RT6A	2x800	2x800
-	-	750	1342	-	-	-	-	-	-	-	-	CK13B	CK12C	RT6A	2x800	2x800

For electrical endurance see page A.94-A.104, but first divide the rated power and current values shown in the table by 1.73. The thermal overload relay should be set at 0.58 In of the motor.

## Star-delta starters

Intro

A

B

C

**D**

E

F

G

H

I

J/X



**Autotransformer starters**

*For AC squirrel cage motors*

This type of starting is used for machines where the resisting torque during starting is less than the motor torque (see torque speed curves):

- Reduce current during starting to the required value (this will depend on the autotransformer voltage ratio selected).
- Reduce motor torque to smooth out mechanical stress on the machine and on the load (see torque speed curves). Reduction of the motor will depend on the autotransformer voltage ratio.

The two requirements for star-delta starting do not apply here. That is to say both end of the three windings do not have to be accessible and the line voltage does not have to be the same as the delta connection voltage.

This system also has the following advantages over star-delta starting:

- required current and starting torque can be selected.
- starting can be effected at various points.
- motor voltage continuity during network switching.

*Torque-speed curve*

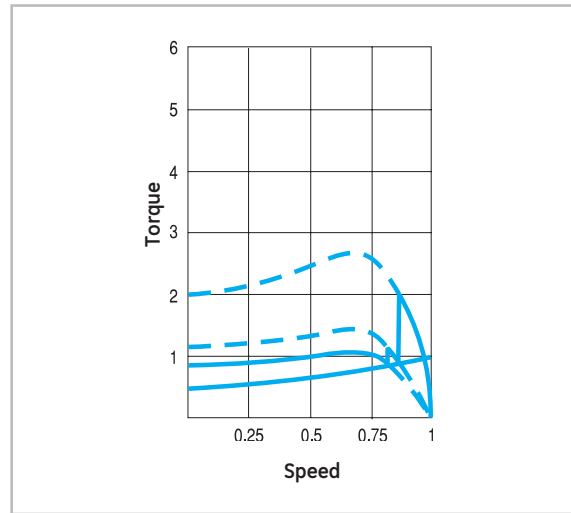

*Current-speed curve*

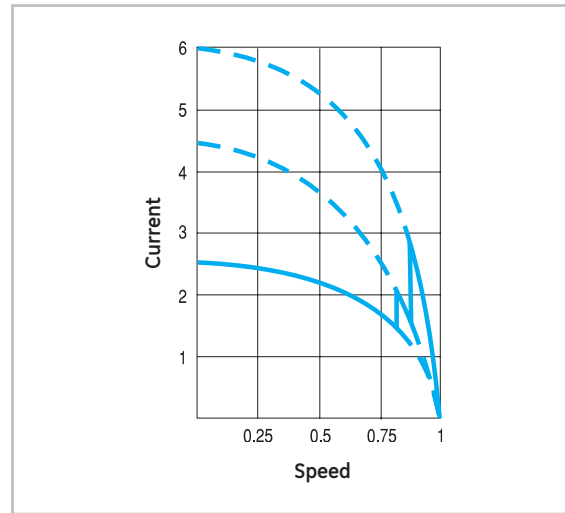

*Diagram*

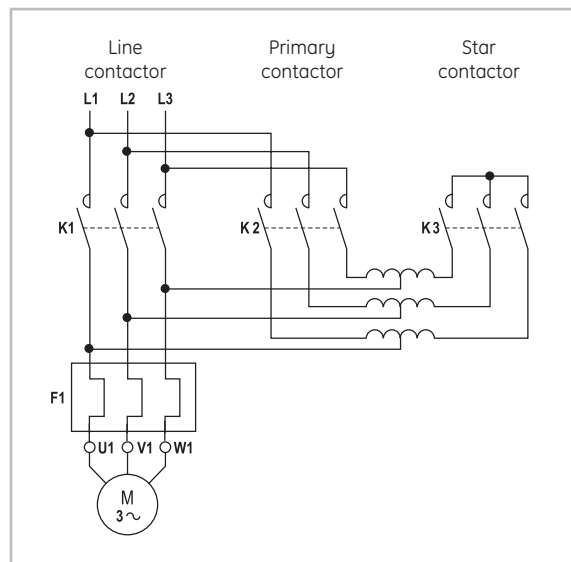



**Contactors for rotor starters**

*For AC slip-ring motors*

This type of starter is used in machines with resisting torque of any value where it is required to:

- Start with reduced peak currents without consequent motor torque reduction, as is the case with high resisting torques and when starting with reduced peak currents is required.
- Control speed for different load or resisting torque values, with reduced peak currents: lifting and transport gear, flow volume control, etc.

Whatever the application, a distinction should be made between the two electrical circuits which are used in this type of starters:

- Stator circuit, present in two categories and having a different breaking current in each:  
 Category AC'2: switching-off motors during running,  $I_c = I_e$   
 Category AC 2: switching-off motors during starting,  $I_c = 2.5 I_e$
- Rotor circuit, with similar characteristics to those in category AC1.

*Torque-speed curve*

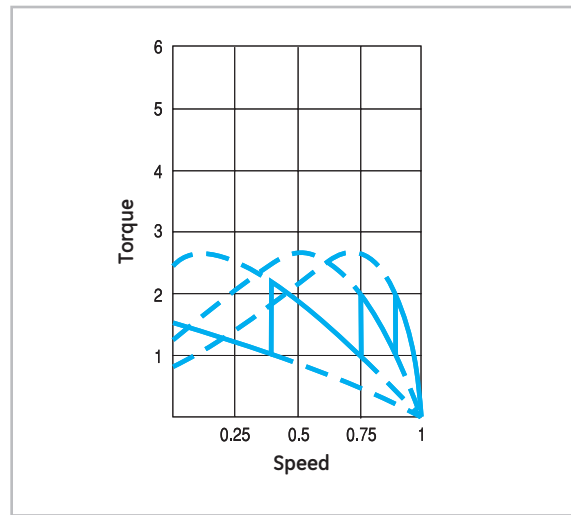

*Current-speed curve*

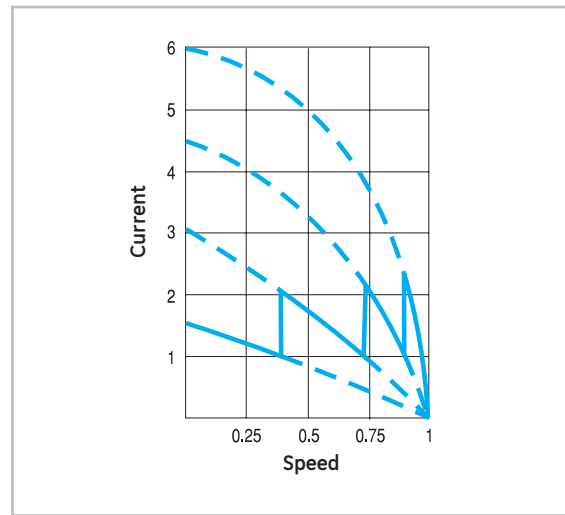

*Diagram*

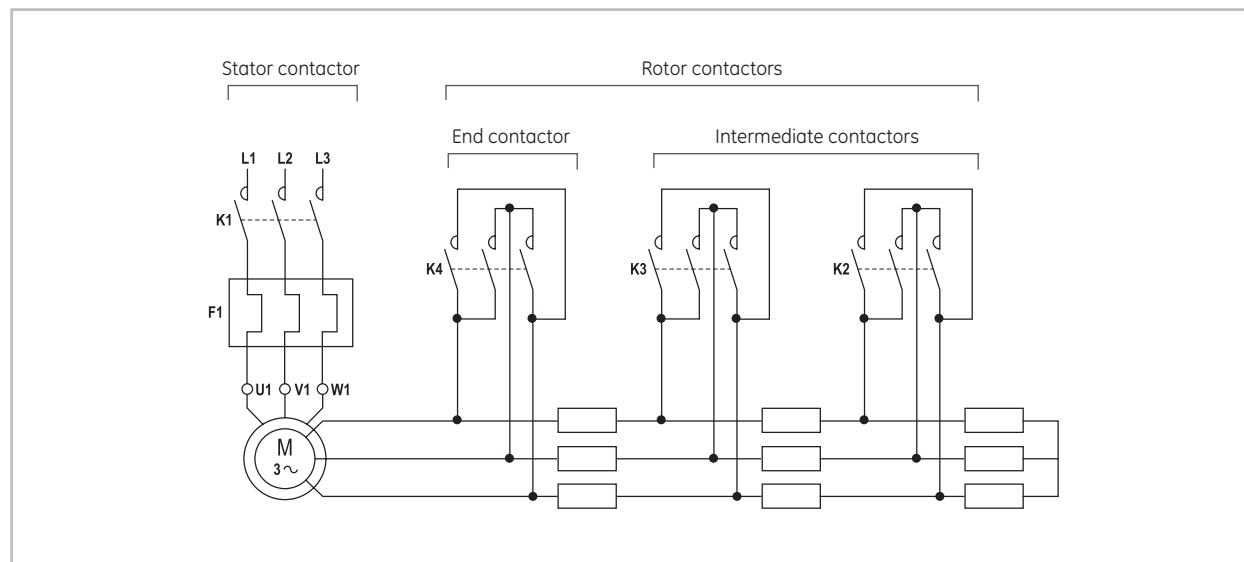







Jogging  
35% AC-2

### Stator circuit (continued)

Motor power (1)							Contactor
230V 220V kW	400V 380V kW	415V kW	440V kW	500V kW	690V kW	1000V kW	
1.4	2.8	3.4	3.4	3.4	4	-	CL00
2.2	3.8	4.5	4.5	4.5	5.5	-	CL01
3	5.5	7.5	7.5	7.5	7.5	-	CL02
4.9	9	10	10	10	11	-	CL25
6.7	12.8	14.8	14.8	14.8	13	-	CL04
7	13	15	15	15	17	-	CL45
9	15	18	18	18	20	-	CL06
10.5	18.5	22	22	22	25	-	CL07
13.5	24	28	28	28	33	-	CL08
18.5	29	33	33	33	40	-	CL09
19.6	34	39	39	39	45	-	CL10
25	45	47	47	47	55	60	CK75C
30	55	63	63	63	77	63	CK08C
35	78	80	80	80	90	75	CK85B
40	75	85	85	85	100	80	CK09B
46	83	100	100	100	135	117	CK95B
63	110	132	132	132	150	132	CK10C
79	136	157	157	160	190	160	CK11C
91	157	165	176	188	220	185	CK12B
115	200	200	200	220	205	202	CK13B

### Rotor circuit (continued)

Rotor current (2)	Rotor voltage without counter-current	Rotor voltage with counter-current	Contactor
14	660	500	CL00
20	660	500	CL01
26	660	500	CL02
42	660	500	CL25
50	660	500	CL04
57	750	600	CL45
70	750	600	CL06
85	750	600	CL07
100	750	600	CL08
120	750	600	CL09
138	750	600	CL10
155	1000	750	CK75C
172	1000	750	CK08C
200	1000	750	CK85B
225	1000	750	CK09B
250	1000	750	CK95B
285	1000	750	CK10C
385	1000	750	CK11C
495	1000	750	CK12B
637	1000	750	CK13B

Electrical endurance 10<sup>6</sup> × 1.3 operations

- (1) Power values shown are not standard as they refer to intermittent service.
- (2) The current shown relates to the delta connection of the contactor poles.  
If the poles are star-connected, divide the values given in the column by 1.5.

## Contactors for rotor speed drives

Intro

A

B

C

**D**

E

F

G

H

I

J/X



## Contactors for connection of power transformers

In this application it is essential to ascertain the no-load inrush current of the transformer  $I_{\mu}$  (magnetisation current) which in the majority of cases determines the size of the contactor.

Two cases are illustrated in the table:

- No-loop inrush current up to 20 times the rated transformer current
- No-loop inrush current up to 40 times the rated transformer current.

The contactor should not cut out the short-circuit current; if the protective devices used are fuses, this condition will be intrinsically complied with.

In the case however of devices with tripping contacts the general line circuit breaker will be driven rather than the contactor coil.

### Selection table

$\frac{I_{\mu}}{I_e} = 20$		$\frac{I_{\mu}}{I_e} = 40$		Contactor
230V 240V kVA	380V 400V kVA	230V 240V kVA	380V 400V kVA	
2	3.5	1	1.75	CL00A
2.75	5	1.37	2.5	CL01A
4	7	2	3.5	CL02A
5.75	10	2.85	5	CL25A
5.75	10	2.85	5	CL03A
7.25	12.5	3.65	6.25	CL04A
9	15.5	4.50	7.75	CL45A
10	17	5	8.5	CL05A
12	21	6	10.5	CL06A
15	25	7.5	12.5	CL07A
20	35	10	16	CL08A
25	40	12.5	20	CL09A
30	50	15	25	CL10A
35	55	17	27	CK75C
40	60	20	30	CK08C
45	75	22	35	CK85B
50	85	25	42.5	CK09B
80	150	40	75	CK10C
100	170	50	85	CK11C
127	215	64	107	CK12B
160	280	80	140	CK13B



## Contactors for capacitors (category AC6b)

The most usual application of capacitors is for centralised automatic power factor (cos φ) correction. A characteristic of capacitors is the high overcurrent which appears as they are connected.

Such overcurrents are due to:

- Harmonic currents produced by saturated transformers, rectifiers, etc.
- Transient currents, the frequency and amplitude of which depend on the network inductance and the capacitor size.
- Additional transient currents arising where a capacitor is connected when others have already been connected, and caused by discharging of the latter.

GE Power Controls contactors are fitted with specially treated hardened alloy contacts which are highly resistant to welding and are therefore capable of withstanding high current peaks on connection.

The operation conditions taken as a basis for usage are:

- Near presence of other previously connected capacitors with a total power of up to eight times that of the capacitor to be connected.
- Shock coils reactances with a minimum inductance of 4μH. These can be obtained by making 4 or 6 turns of 15cm windings on the conductor of each phase.
- Fast discharge resistor for reconnection within 60 seconds.

### Diagram

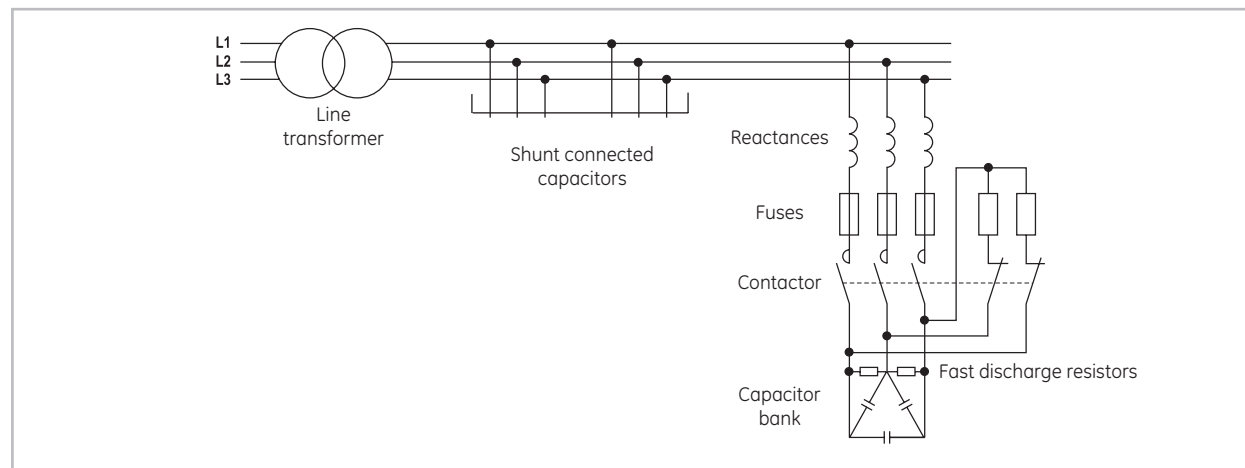

### Selection table

Contactor	Type	Ith	θ ≤ 55°C					θ ≤ 70°C					Fuse gl - gG	I max. (peak)
			220V 230V 240V kvar	400V kvar	415V kvar	500V kvar	690V 660V kvar	220V 230V 240V kvar	400V kvar	415V kvar	500V kvar	690V 660V kvar		
CL00A	A	25	3	5	5.5	6.5	5.7	2.4	4	4.5	5.2	4.5	10	1000
CL01A		25	4.5	9.5	10.5	12.5	11	3.6	6	6.5	10	7	16	1000
CL02A		32	6.5	11	12	14.5	12.5	5.2	8.5	9	11.5	10	25	1000
CL25A		45	7.5	12.5	14	16	15	6.5	10	11	13	12	25	1000
CL03A		45	9	15	16.5	20	17.5	7.2	12	13	16	14	35	2500
CL04A		60	12.5	21	23	27.5	24	10	17	18	22	19.5	40	2500
CL45A		60	16.5	25	27	32	30	13	20	22	25	22	50	2500
CL06A		90	22	40	43	52	50	17	30	33	41	35	80	3500
CL07A		110	25	45	48	58	65	19	35	37	46	40	125	3500
CL08A		110	30	50	54	65	70	22	40	43	52	50	125	3500
CL09A		140	40	65	70	85	95	35	58	62	75	85	160	3500
CL10A		140	45	70	80	90	105	40	60	64	65	75	160	3500
CK75C		250	60	110	118	145	150	48	88	94	116	120	250	5000
CK08C		250	70	125	135	162	170	56	100	107	130	136	250	5000
CK85B		315	80	150	160	195	200	64	120	130	156	160	315	5000
CK09B		315	95	165	177	215	230	85	148	160	192	205	315	5000
CK95B		450	105	190	205	250	288	95	175	188	230	265	450	5500
CK10C		600	135	260	280	340	370	120	235	252	375	330	630	10000
CK11C		700	190	325	350	425	450	152	260	280	340	360	800	10000
CK12B		1000	250	400	430	520	600	200	320	344	416	480	1000	12000
CK13B		1250	315	525	565	685	650	252	420	452	548	520	1250	15000

Electrical endurance: 100.000 operations

### Contactors for capacitors

Intro

A

B

C

D

E

F

G

H

I

J/X



Contactors for control lighting circuits

The characteristics of the most usual lighting systems are as follows:

**Incandescent lamps**

The connection current in very high -of the order of 15 times- rated current. Although this is a very short duration, it is only taken into account in order for the contactor connection current not to be exceeded. The power factor is always maintained at 1.

**Fluorescent lamps**

The connection current is slightly higher than rated current. The power factor is about 0.5. To improve up to 0.9, compensating capacitors can be used. In such cases, the connection power of the capacitor must be taken into account, the effect of which is appreciably greater on the smaller contactors.

**High pressure mercury vapour lamps**

The connection current varies, depending on type, between 1.6 and 2 times the rated current and will hold for between 3 and 5 minutes.

The power factor is of the order of 0.6 and this can be improved up to approximately unit value by means of compensating capacitors. In such cases, the connection power of the capacitor must be taken into account, the effect of which is appreciably greater on the smaller contactors.

**High pressure sodium vapour lamps**

The connection current values varies, depending on type, between 1.3 and 1.6 times the rated current and will hold between 3 and 5 minutes.

The power factor is of the order of 0.45 and this can be improved up to approximately unit value by means of compensating capacitors. In such cases, the connection power of the capacitor must be taken into account, the effect of which is appreciably greater on the smaller contactors.

Selection table

Types	W	A	μF	MCR	MC0	MC1	MC2	RL	CL00	CL01	CL02	CL25
Incandescent	60	0.27		27	37	59	59	59	62	62	70	77
	100	0.45		16	22	35	35	35	40	40	50	60
	200	0.91		8	11	17	17	17	20	20	25	30
	300	1.36		5	7	11	11	11	13	13	17	20
	500	2.27		3	4	7	7	7	8	8	10	12
	1000	4.5		1	2	3	3	3	4	4	5	6
Fluorescent Single arrangement Without compensation	2000	9.1		0	1	1	1	1	1	1	2	3
	15	0.23		51	61	79	79	79	88	98	126	155
	20	0.37		32	38	49	49	49	57	61	78	110
	40	0.44		28	33	41	41	41	48	51	66	93
	65	0.7		18	21	26	26	26	30	32	41	58
	100	1.5		8	10	12	12	12	14	16	19	27
Fluorescent Single arrangement With compensation	15	0.23	3.5	26	32	49	49	49	61	77	94	111
	20	0.25	4.5	20	25	38	38	38	48	61	74	87
	40	0.3	4.5	20	25	38	38	38	48	61	74	87
	65	0.45	7	13	14	25	25	25	31	39	47	56
	100	0.7	18	5	6	9	9	9	11	14	17	21
	250	2.13		5	5	5	6	6	6	8	10	12
High pressure mercury vapour Without compensation	400	3.25		3	3	4	4	4	4	5	6	8
	700	5.4		2	2	2	2	2	2	3	4	5
	1000	7.5		1	1	2	2	2	2	2	3	3
	250	1.3	20	9	9	9	9	11	11	14	18	22
High pressure mercury vapour With compensation	400	2.1	25	7	7	7	7	7	7	9	11	14
	700	3.6	40	5	5	5	5	4	4	5	6	8
	1000	5.3	60	3	3	3	3	3	3	3	4	5
	250	3		3	3	4	4	4	4	5	7	9
High pressure sodium vapour Without compensation	400	4.4		2	2	3	3	3	3	4	5	6
	1000	10.3		1	1	1	1	1	1	2	2	2
	250	1.45	40	5	5	5	5	10	10	12	16	20
	400	2.5	45	4	4	4	4	6	6	7	9	11
High pressure sodium vapour With compensation	1000	5.5	100	2	2	2	2	3	3	3	4	5
	250	2.17	-	3	3	4	4	4	4	5	7	9
	400	3.48	-	2	2	2	3	3	3	3	4	6
	700	6.09	-	1	1	1	1	1	1	2	2	3
Metal iodide Without compensation	1000	8.7	-	1	1	1	1	1	1	1	2	2
	2000	17.39	-	0	0	0	1	1	1	1	1	1
	250	1.4	32	0	6	6	7	7	7	9	11	16
	400	2.0	45	0	4	5	5	5	5	6	8	11
Metal iodide With compensation	700	3.6	65	0	2	3	3	3	3	3	4	6
	1000	5.3	85	0	2	2	2	2	2	2	3	4
	2000	10.6	100	0	0	0	0	0	1	1	2	2



## Diagrams

### Single-phase circuit

The total number of lamps will be as shown in the table.

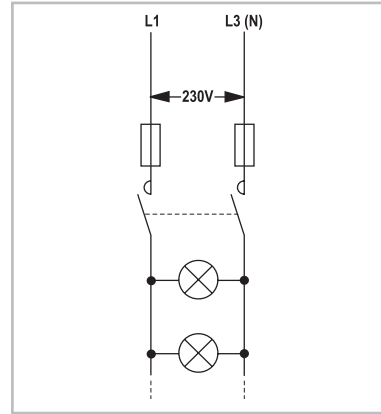

### 3-phase circuit, lamps delta-connected

The total number of lamps will be as shown in the table, multiplied by 1.73 and distributed in three equal quantities.

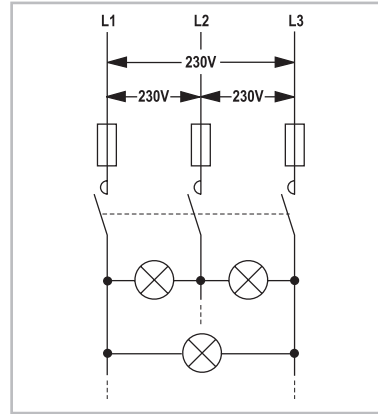

### 3-phase circuit, lamps star-connected

The total number of lamps will be as shown in the table, multiplied by 3 and distributed in three equal quantities.

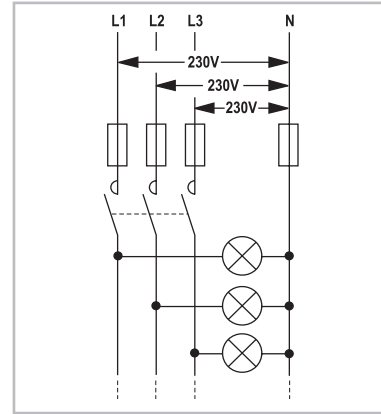

Maximum number of lamps per phase at 230V

CL03	CL04	CL45	CL06	CL07	CL08	CL09	CL10	CK75C	CK08C	CK09	CK95	CK10	CK11	CK12	CK13
77	85	122	156	191	222	264	284	333	410	555	820	1320	1550	1860	1860
60	66	73	95	116	133	160	170	200	246	333	490	790	930	1120	1120
30	33	36	47	58	66	79	84	99	122	165	240	390	460	550	550
20	22	24	31	38	44	53	56	66	81	110	165	260	300	370	370
12	12	14	19	23	26	31	33	39	48	66	95	155	185	220	220
6	6	7	9	11	13	16	17	20	24	33	50	80	90	110	110
3	3	3	4	5	7	8	8	10	12	16	25	40	45	55	55
177	224	237	355	390	434	496	553	790	988	1245	1770	2340	2740	3910	4890
125	139	147	221	243	270	309	344	490	614	774	1090	1460	1700	2430	3040
105	118	124	186	204	227	260	289	413	516	650	920	1220	1430	2045	2550
66	74	78	116	127	142	163	181	259	324	409	570	770	900	1280	1600
30	34	36	54	59	66	76	85	121	151	190	270	360	420	600	750
119	134	149	191	232	273	312	347	496	621	786	900	1240	1450	1740	1740
92	103	115	148	180	212	243	270	385	482	610	700	960	1120	1350	1350
92	103	115	148	180	212	243	270	385	482	610	700	960	1120	1350	1350
59	66	74	95	115	136	155	173	248	310	393	440	610	720	860	860
23	23	29	37	45	53	60	67	96	120	152	170	240	280	330	330
14	15	18	27	30	33	36	42	60	75	95	136	181	211	302	377
9	10	12	18	20	22	24	28	40	49	62	89	119	138	198	247
5	6	7	11	12	13	14	17	24	30	38	54	71	83	119	149
4	4	5	8	9	9	10	12	17	21	27	39	51	60	86	107
31	27	33	49	55	60	66	77	109	156	156	171	311	311	374	467
25	17	20	31	34	37	41	48	87	125	125	137	249	249	299	374
16	10	12	18	20	22	24	28	54	78	78	86	156	156	187	234
10	7	8	12	13	15	16	19	36	52	52	57	104	104	125	156
10	11	13	19	21	24	26	30	43	54	68	96	129	150	214	268
7	7	9	13	15	16	18	20	29	37	46	66	88	102	146	183
3	3	4	6	6	7	7	9	12	16	20	28	37	44	62	78
16	25	30	44	49	54	59	69	97	131	131	146	263	263	319	398
14	14	17	26	29	31	34	40	51	72	72	80	145	145	174	217
7	6	8	12	13	14	16	18	23	33	33	36	65	65	78	98
12	12	12	19	21	23	25	29	41	52	65	93	124	145	207	259
8	8	8	12	13	14	16	18	26	32	41	58	78	91	129	162
4	4	4	7	7	8	9	10	15	18	23	33	44	52	74	92
3	3	3	5	5	6	6	7	10	13	16	23	31	36	52	65
2	2	2	2	3	3	3	4	5	6	8	12	16	18	26	32
21	21	21	32	36	39	43	50	68	97	97	107	195	195	234	292
15	15	15	23	25	28	30	35	48	69	69	76	138	138	166	208
8	8	8	13	14	15	17	19	34	48	48	53	96	96	115	144
6	6	6	8	9	10	11	13	26	37	37	40	73	73	88	110
3	3	3	4	5	5	6	7	22	31	31	34	62	62	75	93

## Contactors for lighting circuits

### Intro

A

B

C

D

E

F

G

H

I

J/X



Contactors for DC - Max. operational current Ie (A) - DC utilization categories

Category DC1. L/R ≤ 1ms

Ue	Poles in serie	MC0	MC1	MC2	CL00	CL01	CL02	CL25	CL03	CL04	CL45	CL05	CL06	CL07	CL08	CL09	CL10
24V	1	6	9	9	18	18	18	25	25	32	40	50	50	65	65	80	80
	2	8	12	12	25	25	32	45	45	60	60	90	90	110	110	140	140
	3	15	20	20	25	25	32	45	45	60	60	90	90	110	110	140	140
	4	15	20	20	-	25	32	-	45	60	-	90	-	110	-	140	-
48V	1	5	7.5	7.5	15	15	15	20	20	25	35	45	45	55	55	70	70
	2	8	12	12	25	25	32	45	45	60	60	90	90	110	110	140	140
	3	12	16	16	25	25	32	45	45	60	60	90	90	110	110	140	140
	4	15	20	20	-	25	32	-	45	60	-	90	-	110	-	140	-
60V	1	4	6	6	12	12	12	18	18	18	32	40	40	50	50	65	65
	2	6	9	9	25	25	32	45	45	60	60	90	90	110	110	140	140
	3	12	16	16	25	25	32	45	45	60	60	90	90	110	110	140	140
	4	15	20	20	-	25	32	-	45	60	-	90	-	110	-	140	-
125V	1	1.6	2.5	2.5	6	6	6	8	8	8	8	16	16	16	16	16	16
	2	4	6	6	18	18	18	25	25	45	45	80	80	90	90	110	110
	3	5	10	10	25	25	25	32	45	60	60	90	90	110	110	140	140
	4	5	10	10	-	25	32	-	45	60	-	90	-	110	-	140	-
220V	1	0.2	0.36	0.36	0.8	0.8	0.8	0.8	1	1	1	2	2	2	2	2	2
	2	1.7	2.6	2.6	7.5	7.5	7.5	7.5	8	8	8	20	20	20	20	20	20
	3	4	8	8	25	25	25	32	45	50	50	90	90	110	110	140	140
	4	4	8	8	-	25	32	-	45	60	-	90	-	110	-	140	-
440V	1	0.09	0.13	0.13	0.4	0.4	0.4	0.4	0.5	0.5	0.5	0.8	0.8	0.8	0.8	0.8	0.8
	2	0.26	0.4	0.4	0.8	0.8	0.8	0.8	1	1	1	2	2	2	2	2	2
	3	0.5	1	1	8	8	8	10	10	10	10	15	15	15	15	15	15
	4	0.5	1	1	-	15	15	-	20	25	-	80	-	90	-	110	-
600V	1	-	-	-	-	-	-	-	-	-	-	-	-	-	-	-	-
	2	-	-	-	0.4	0.4	0.4	0.4	0.5	0.5	0.5	1	1	1	1	1	1
	3	-	-	-	4	4	4	5	5	5	7.5	7.5	7.5	7.5	7.5	7.5	7.5
	4	-	-	-	-	8	10	-	12	12	-	50	-	65	-	75	-

Category DC3. L/R ≤ 2.5ms

Ue	Poles in serie	MC0	MC1	MC2	CL00	CL01	CL02	CL25	CL03	CL04	CL45	CL05	CL06	CL07	CL08	CL09	CL10
24V	1	-	-	-	12	12	12	18	18	25	32	40	40	50	50	65	65
	2	4	9	9	18	18	18	25	25	40	40	65	65	80	80	105	105
	3	8	12	12	18	18	18	25	25	40	40	65	65	80	80	105	105
	4	-	-	-	-	18	18	-	25	40	-	65	-	80	-	105	-
48V	1	-	-	-	9	9	9	12	12	18	20	30	30	35	35	45	45
	2	3	6	6	18	18	18	25	25	40	40	65	65	80	80	105	105
	3	6	9	9	18	18	18	25	25	40	40	65	65	80	80	105	105
	4	-	-	-	-	18	18	-	25	40	-	65	-	80	-	105	-
60V	1	-	-	-	7.5	7.5	7.5	10	10	15	15	25	25	30	30	35	35
	2	3	6	6	18	18	18	25	25	40	40	65	65	80	80	105	105
	3	6	9	9	18	18	18	25	25	40	40	65	65	80	80	105	105
	4	-	-	-	-	18	18	-	25	40	-	65	-	80	-	105	-
125V	1	-	-	-	2	2	2	3	3	3	3	3	3	3	3	3	3
	2	0.85	4.5	4.5	10	10	12	18	18	25	32	50	50	60	60	80	80
	3	1.7	6	6	15	15	18	25	25	32	40	35	35	80	80	105	105
	4	-	-	-	-	15	18	-	25	32	-	35	-	80	-	105	-
220V	1	-	-	-	0.6	0.6	0.6	0.6	0.6	0.6	0.8	0.8	0.8	0.8	0.8	0.8	0.8
	2	0.35	1.2	1.2	2	2	2	2	2	2	7	7	7	7	7	7	7
	3	0.7	2.5	2.5	12	12	12	18	18	25	32	50	50	65	65	95	95
	4	-	-	-	-	15	18	-	32	32	-	65	-	80	-	105	-
440V	1	-	-	-	-	-	-	-	-	-	-	-	-	-	-	-	-
	2	0.05	0.15	0.15	0.3	0.3	0.3	0.3	0.5	0.5	0.5	1	1	1	1	1	1
	3	0.13	0.3	0.3	1.5	1.5	1.5	1.5	3	3	3	3	3	3	3	3	3
	4	-	-	-	-	6	6	-	6	6	-	50	-	65	-	75	-
600V	1	-	-	-	-	-	-	-	-	-	-	-	-	-	-	-	-
	2	-	-	-	-	-	-	-	-	-	-	-	-	-	-	-	-
	3	-	-	-	0.8	0.8	0.8	0.8	1.5	1.5	1.5	1.5	1.5	1.5	1.5	1.5	1.5
	4	-	-	-	-	2.5	2.5	-	2.5	2.5	-	25	-	30	-	35	-

Category DC5. L/R ≤ 15ms

Ue	Poles in serie	MC0	MC1	MC2	CL00	CL01	CL02	CL25	CL03	CL04	CL45	CL05	CL06	CL07	CL08	CL09	CL10
24V	1	-	-	-	12	12	12	18	18	25	32	40	40	50	50	65	65
	2	3	4.5	4.5	18	18	18	25	25	40	40	65	65	80	80	105	105
	3	6	9	9	18	18	18	25	25	40	40	65	65	80	80	105	105
	4	-	-	-	-	18	18	-	25	40	-	65	-	80	-	105	-
48V	1	-	-	-	9	9	9	12	12	18	20	30	30	35	35	45	45
	2	2.5	4	4	18	18	18	25	25	40	40	65	65	80	80	105	105
	3	6.5	8	8	18	18	18	25	25	40	40	65	65	80	80	105	105
	4	-	-	-	-	18	18	-	25	40	-	65	-	80	-	105	-
60V	1	-	-	-	7.5	7.5	7.5	10	10	15	15	25	25	30	30	35	35
	2	2	3	3	18	18	18	25	25	40	40	65	65	80	80	105	105
	3	5	7	7	18	18	18	25	25	40	40	65	65	80	80	105	105
	4	-	-	-	-	18	18	-	25	40	-	65	-	80	-	105	-
125V	1	-	-	-	0.8	0.8	0.8	0.8	1.2	1.2	1.2	1.2	1.2	1.2	1.2	1.2	1.2
	2	0.65	1.5	1.5	5	5	5	5	5	5	5	50	50	60	60	85	85
	3	1.3	2	2	15	15	15	20	20	25	32	60	60	70	70	95	95
	4	-	-	-	-	15	18	-	25	32	-	65	-	80	-	105	-
220V	1	-	-	-	-	-	-	-	-	-	-	0.5	0.5	0.5	0.5	0.5	0.5
	2	0.16	0.26	0.26	0.8	0.8	0.8	0.8	0.8	0.8	0.8	3	3	3	3	4	4
	3	0.5	0.8	0.8	3	3	3	3	3	3	3	7	7	7	7	7	7
	4	-	-	-	-	10	10	-	15	15	-	65	-	75	-	95	-
440V	1	-	-	-	-	-	-	-	-	-	-	-	-	-	-	-	-
	2	-	-	-	-	-	-	-	-	-	-	-	-	-	-	-	-
	3	0.4	0.1	1.1	0.5	0.5	0.5	0.5	0.7	0.7	0.7	1	1	1	1	1	1
	4	-	-	-	-	2	2	-	4	4	-	40	-	50	-	60	-
600V	1	-	-	-	-	-	-	-	-	-	-	-	-	-	-	-	-
	2	-	-	-	-	-	-	-	-	-	-	-	-	-	-	-	-
	3	-	-	-	-	-	-	-	-	-	-	-	-	-	-	-	-
	4	-	-	-	-	0.75	0.75	-	2.5	2.5	-	20	-	25	-	30	-

Contactors for DC application

Intro

A

B

C

D

E

F

G

H

I

J/X



Max. operational current  $I_e$  (A) - DC utilization categories (continued)

Category DC1.  $L/R \leq 1ms$

Ue	Poles in serie	CK07	CK75	CK08	CK85	CK09	CK95	CK10	CK11	CK12	CK13
24V	1	150	200	200	250	250	350	500	600	800	1000
	2	200	250	250	315	315	450	600	700	1000	1250
	3	200	250	250	315	315	450	600	700	1000	1250
	4	200	-	250	-	315	450	600	700	1000	1250
48V	1	125	170	170	200	200	295	425	500	600	850
	2	140	175	175	220	220	315	425	480	700	850
	3	200	250	250	315	315	500	600	700	1000	1250
	4	200	-	250	-	315	500	600	700	1000	1250
60V	1	100	140	140	175	175	245	350	420	560	700
	2	140	175	175	220	220	315	425	480	700	850
	3	200	250	250	315	315	500	600	700	1000	1250
	4	200	-	250	-	315	500	600	700	1000	1250
125V	1	20	25	25	30	30	50	60	70	100	125
	2	110	200	200	250	250	300	400	500	600	1000
	3	200	250	250	315	315	500	600	700	1000	1250
	4	200	-	250	-	315	500	600	700	1000	1250
220V	1	-	-	-	-	-	-	-	-	-	-
	2	65	110	110	150	150	200	250	250	300	400
	3	200	250	250	315	315	500	600	700	1000	1250
	4	200	-	250	-	315	500	600	700	1000	1250
440V	1	-	-	-	-	-	-	-	-	-	-
	2	-	-	-	-	-	-	-	-	-	-
	3	60	120	120	150	150	180	240	300	400	480
	4	110	-	200	-	250	315	400	500	700	800
600V	1	-	-	-	-	-	-	-	-	-	-
	2	-	-	-	-	-	-	-	-	-	-
	3	32	65	65	80	80	95	130	160	215	250
	4	85	-	100	-	130	170	215	265	375	430

Category DC3.  $L/R \leq 2.5ms$

Ue	Poles in serie	CK07	CK75	CK08	CK85	CK09	CK95	CK10	CK11	CK12	CK13
24V	1	105	150	185	205	250	309	420	550	700	825
	2	105	150	185	205	250	309	420	550	700	825
	3	105	150	185	205	250	309	420	550	700	825
	4	105	-	185	-	250	309	420	550	700	825
48V	1	70	105	130	140	175	215	290	385	490	575
	2	105	150	185	205	250	309	420	550	700	825
	3	105	150	185	205	250	309	420	550	700	825
	4	105	-	185	-	250	309	420	550	700	825
60V	1	55	85	105	110	140	175	230	300	390	460
	2	105	150	185	205	250	309	420	550	700	825
	3	105	150	185	205	250	309	420	550	700	825
	4	105	-	185	-	250	309	420	550	700	825
125V	1	20	25	25	30	30	50	60	70	100	125
	2	105	150	185	205	250	309	420	550	700	825
	3	105	150	185	205	250	309	420	550	700	825
	4	105	-	185	-	250	309	420	550	700	825
220V	1	-	-	-	-	-	-	-	-	-	-
	2	10	60	70	80	85	95	140	185	225	400
	3	105	150	185	205	250	309	420	550	700	825
	4	105	-	185	-	250	309	420	550	700	825
440V	1	-	-	-	-	-	-	-	-	-	-
	2	-	-	-	-	-	-	-	-	-	-
	3	8	50	55	65	70	80	120	150	180	320
	4	80	-	105	-	185	205	250	300	400	700
600V	1	-	-	-	-	-	-	-	-	-	-
	2	-	-	-	-	-	-	-	-	-	-
	3	4	25	25	30	35	40	60	75	90	165
	4	40	-	50	-	90	100	125	150	200	350

Category DC5.  $L/R \leq 15ms$

Ue	Poles in serie	CK07	CK75	CK08	CK85	CK09	CK95	CK10	CK11	CK12	CK13
24V	1	105	150	185	205	250	309	420	550	700	825
	2	105	150	185	205	250	309	420	550	700	825
	3	105	150	185	205	250	309	420	550	700	825
	4	105	-	185	-	250	309	420	550	700	825
48V	1	60	90	110	120	150	185	250	330	420	495
	2	105	150	185	205	250	309	420	550	700	825
	3	105	150	185	205	250	309	420	550	700	825
	4	105	-	185	-	250	309	420	550	700	825
60V	1	55	85	105	110	140	175	230	300	390	460
	2	105	150	185	205	250	309	420	550	700	825
	3	105	150	185	205	250	309	420	550	700	825
	4	105	-	185	-	250	309	420	550	700	825
125V	1	15	20	20	25	25	40	50	60	80	100
	2	80	95	105	150	185	205	250	300	400	700
	3	105	150	185	205	250	309	420	550	700	825
	4	105	-	185	-	250	309	420	550	700	825
220V	1	-	-	-	-	-	-	-	-	-	-
	2	8	50	55	65	70	80	120	150	180	320
	3	80	95	105	150	185	205	250	300	400	700
	4	105	-	185	-	250	309	420	550	700	825
440V	1	-	-	-	-	-	-	-	-	-	-
	2	-	-	-	-	-	-	-	-	-	-
	3	5	40	40	50	50	60	90	100	100	200
	4	65	-	95	-	150	185	205	250	300	400
600V	1	-	-	-	-	-	-	-	-	-	-
	2	-	-	-	-	-	-	-	-	-	-
	3	40	45	50	75	90	100	125	150	200	350
	4	35	-	45	-	75	90	100	125	150	200

Contactors for DC application

Intro

A

B

C

D

E

F

G

H

I

J/X



Dimensional drawings

Fuseless starter - GPS1 rocker + Minicontactor MC

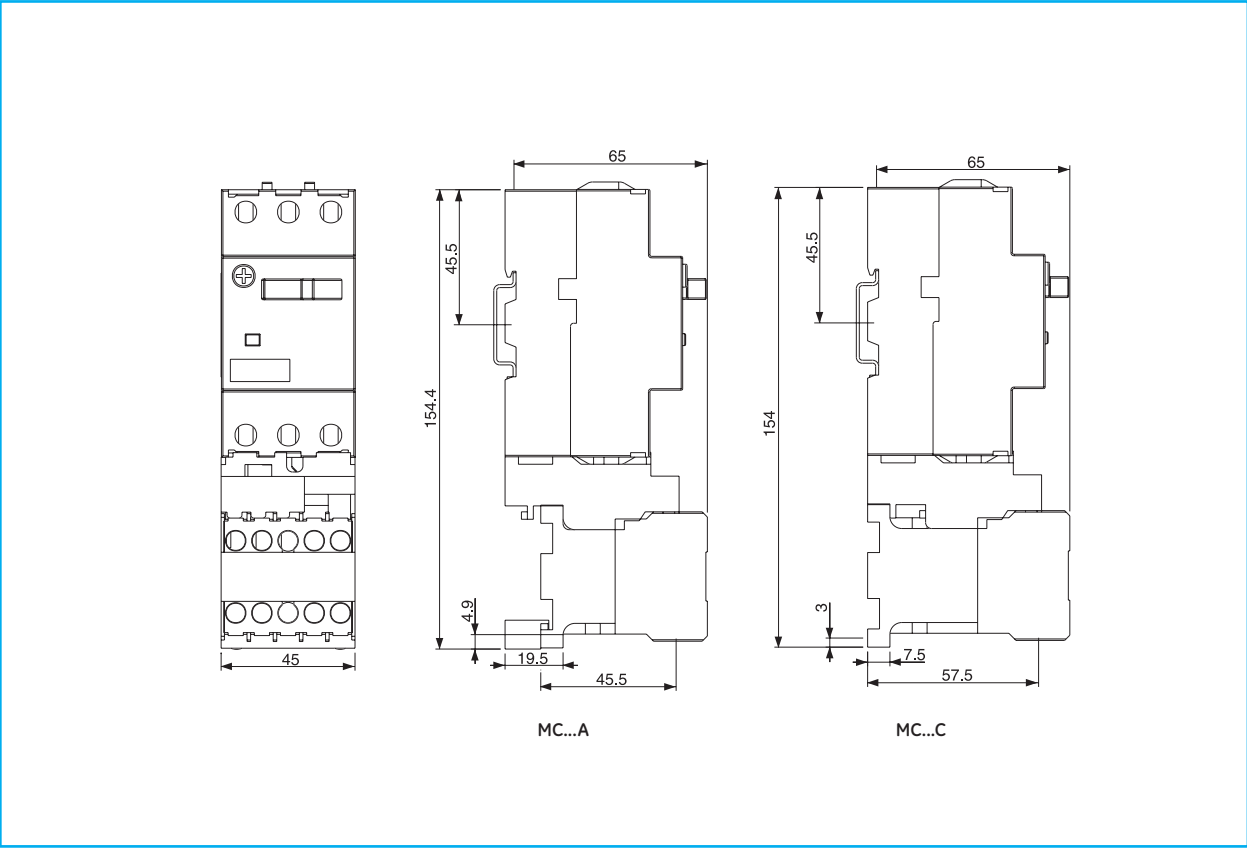

Fuseless starter - GPS1 rocker + Contactor CL00-CL01-CL02

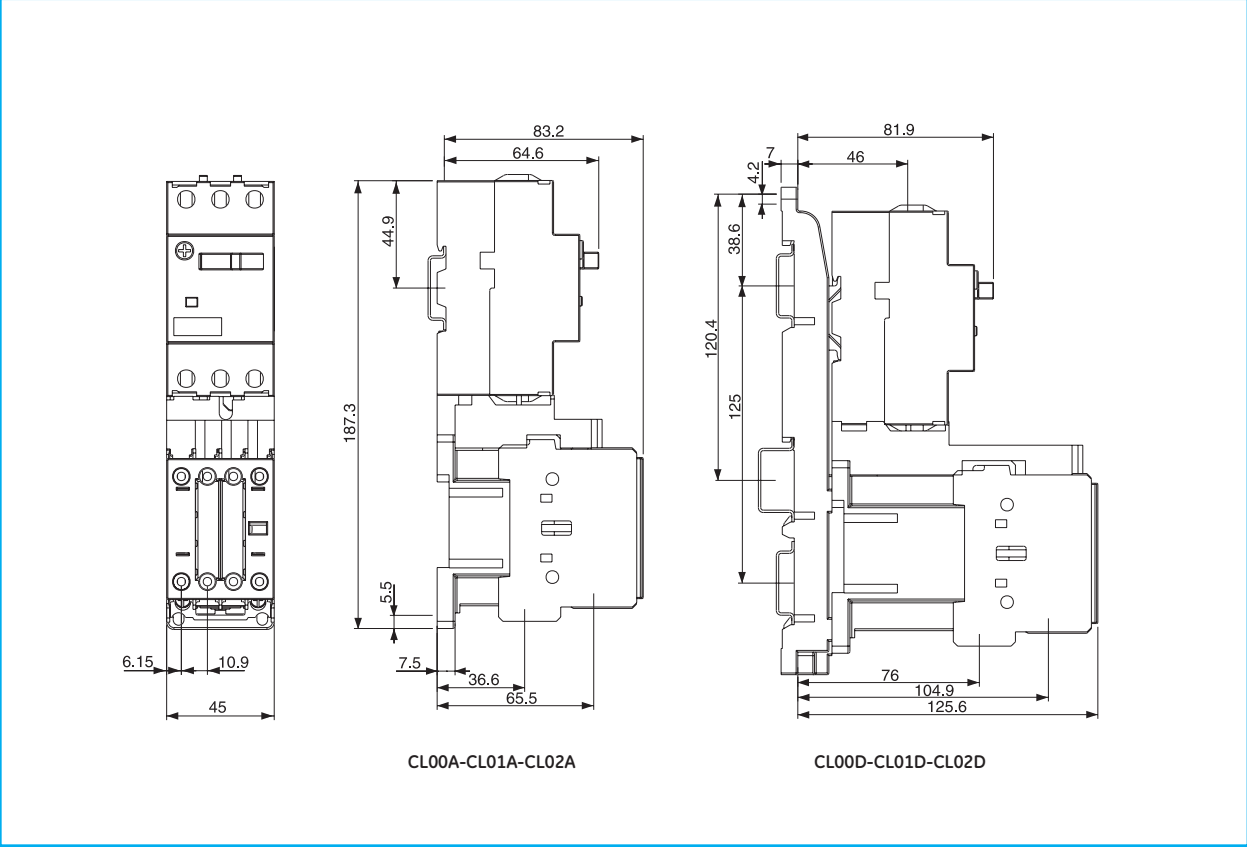



Fuseless starter - GPS1 rocker + Contactor CL25

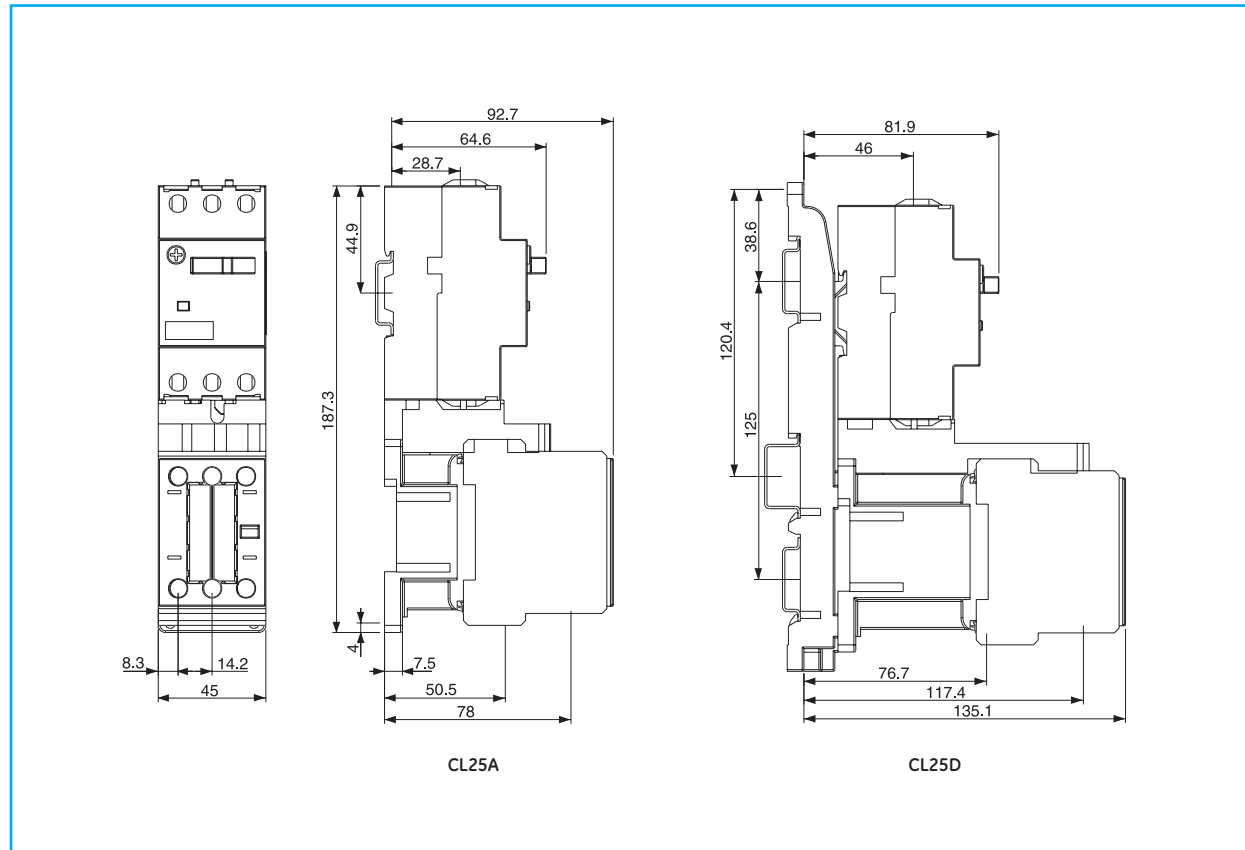

Fuseless starter - GPS2 + Contactor CL03-CL04

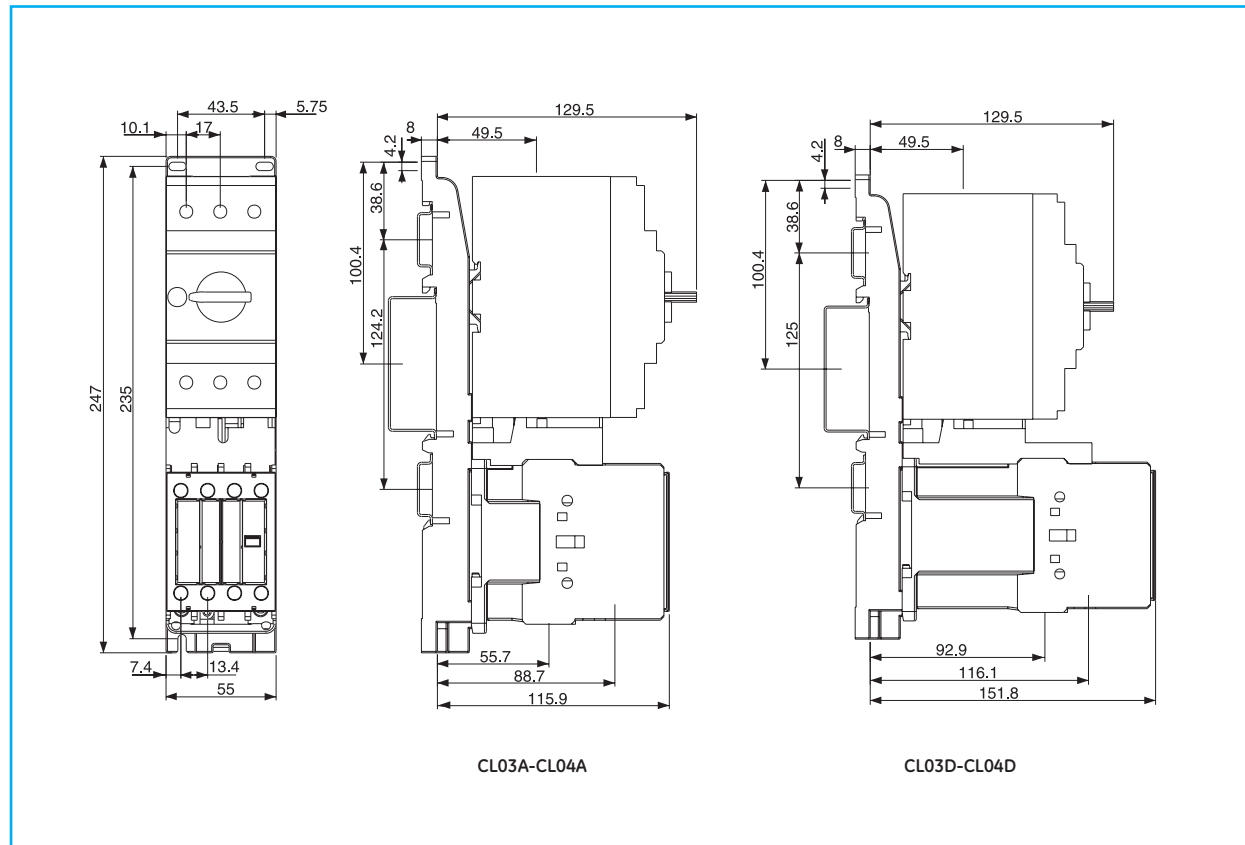

Dimensions

Intro

A

B

C

**D**

E

F

G

H

I

J/X



Dimensional drawings

Fuseless starter - GPS2 + Contactor CL45

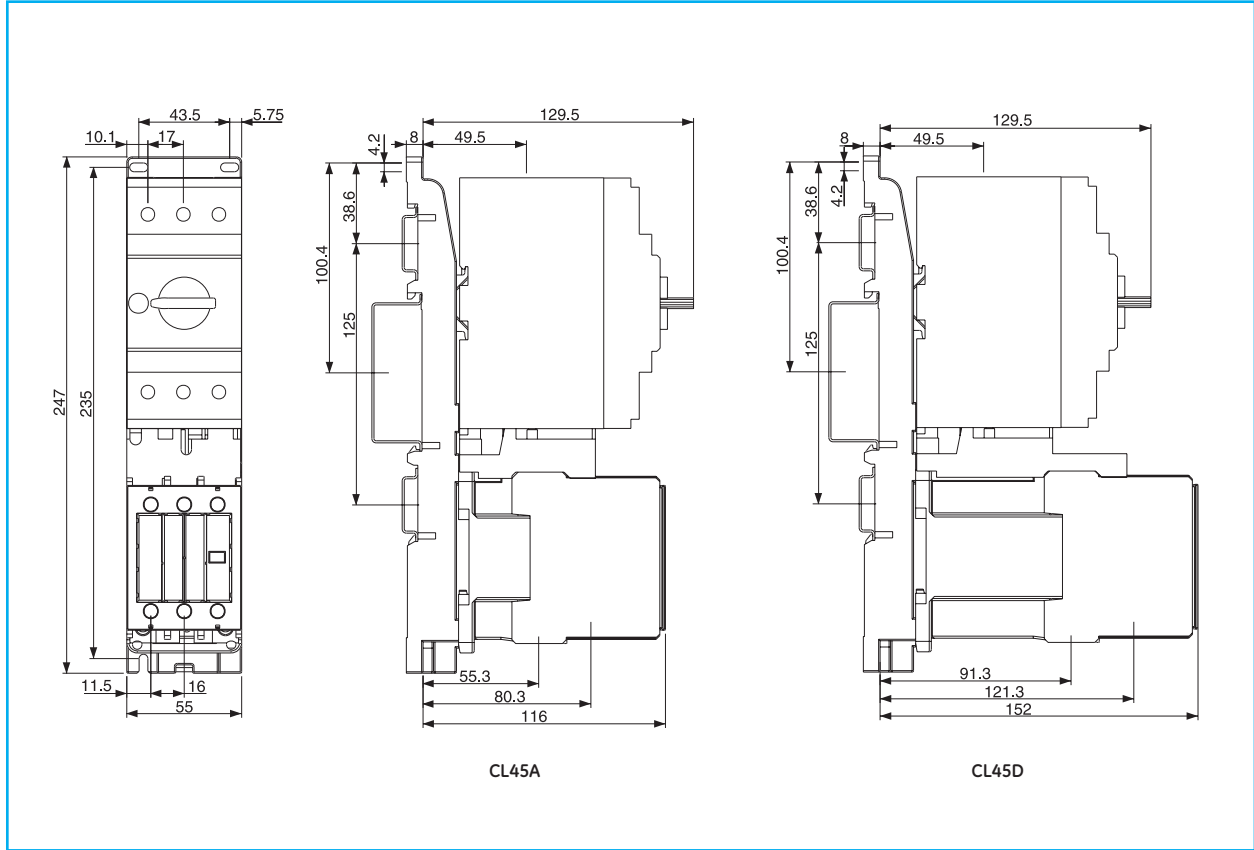

Fuseless starter - GPS2 + Contactor CL06-CL08

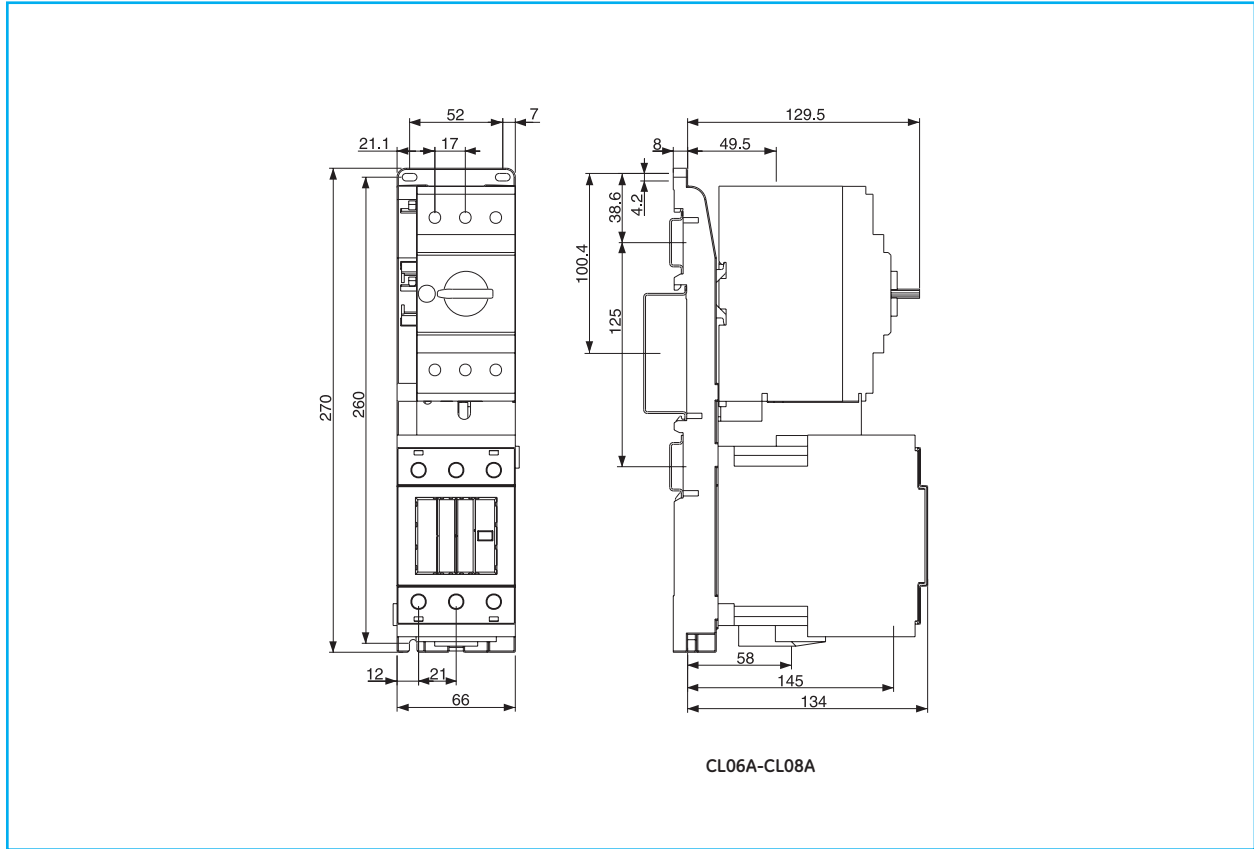

Fuseless starter - Record Plus + Contactor CL09 + Thermal overload relay RT2

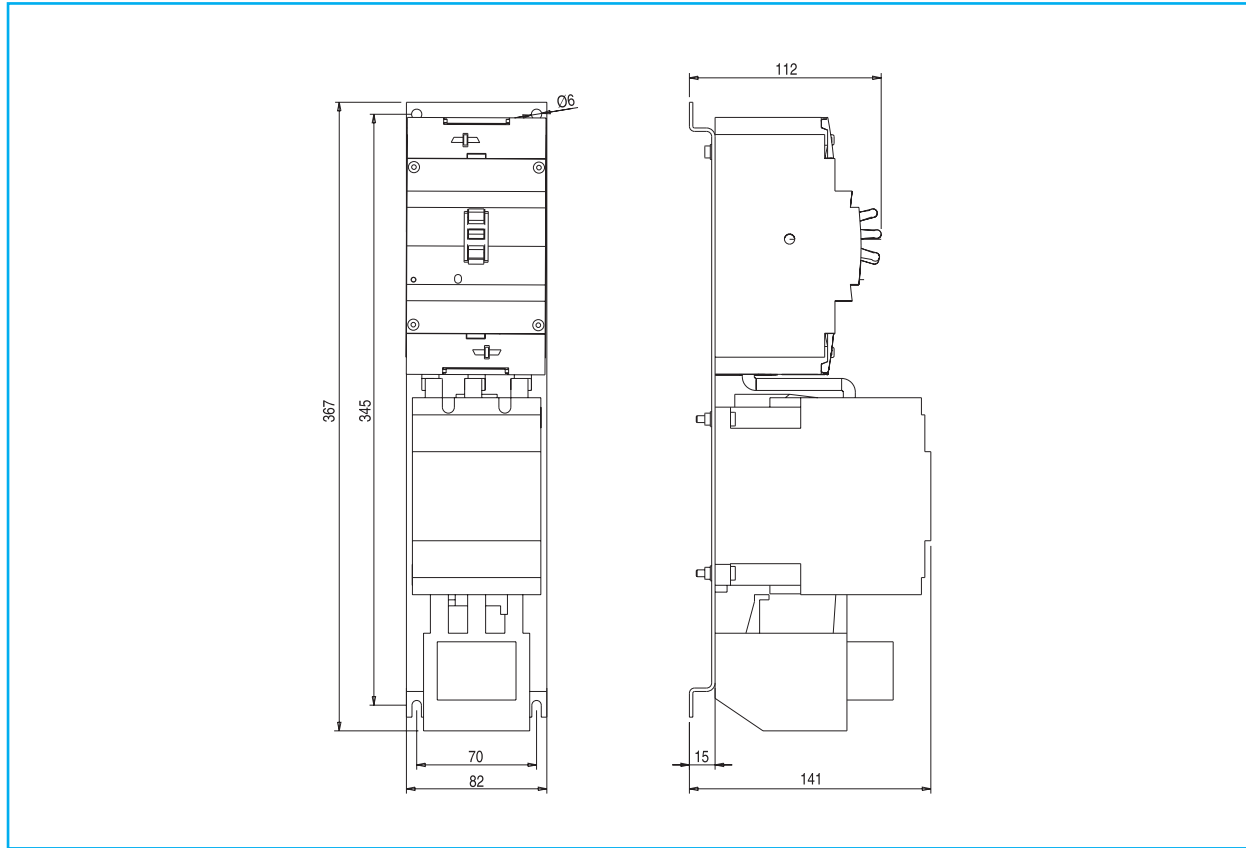

Dimensions

Intro

A

B

C

**D**

E

F

G

H

I

J/X



## Wiring diagrams

### Series M. Direct-on-line starter with reset

Power circuit

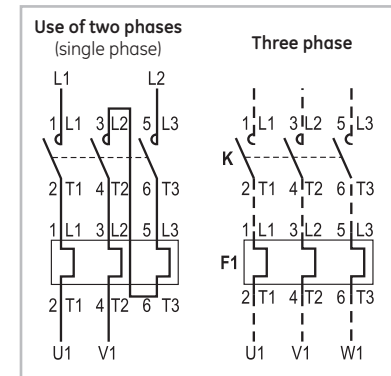

Control circuit

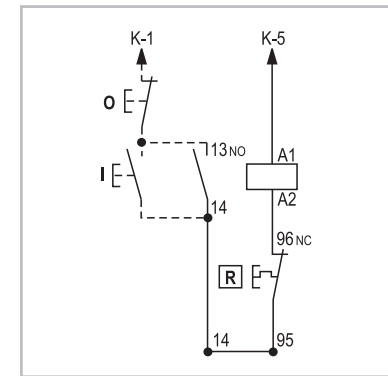

Control by two or more push-buttons

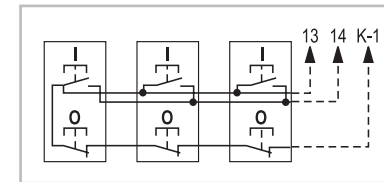

### Series M. Direct-on-line starter with start/emergency stop push-button

Power circuit

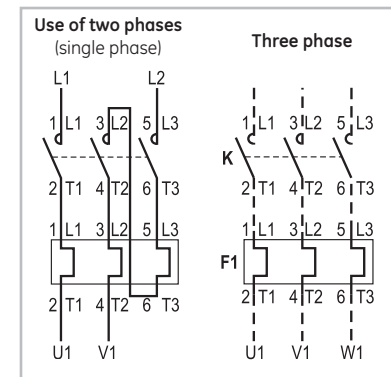

Control circuit

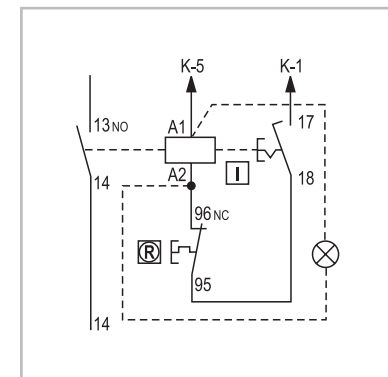

Control by two or more push-buttons

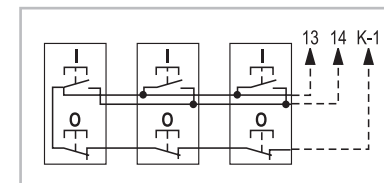

## Series CL. Direct-on-line starter

Power circuit

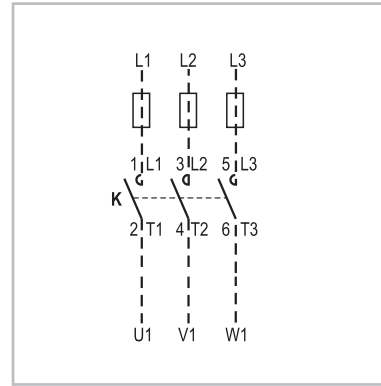

Control circuit

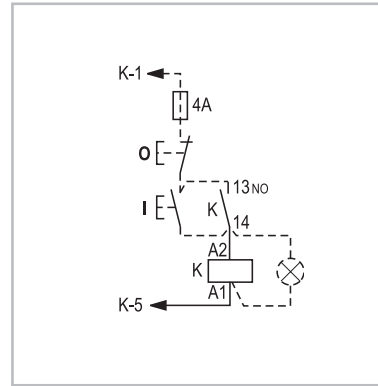

Control by two or more push-buttons

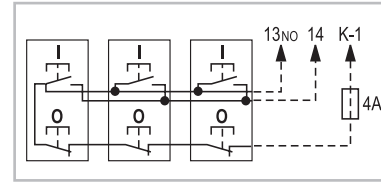

Control by permanent contact

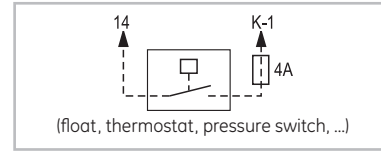

## Series CL. Direct-on-line starter with reset push-button

Power circuit

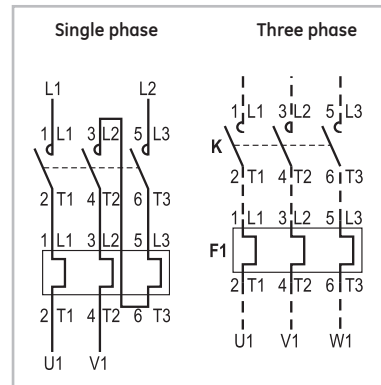

Control circuit

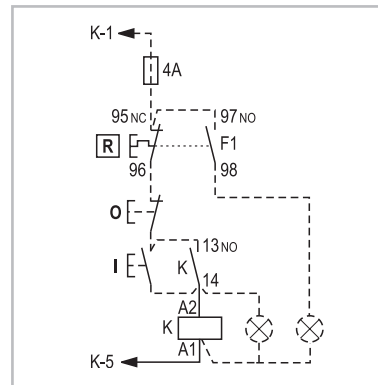

Control by two or more push-buttons

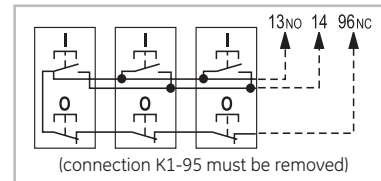

Control by permanent contact

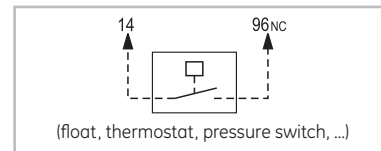

## Series CL. Direct-on-line starter with start/stop/reset push-button

Power circuit

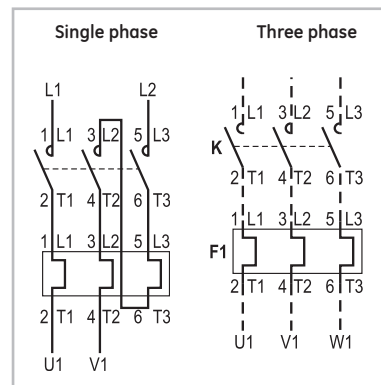

Control circuit

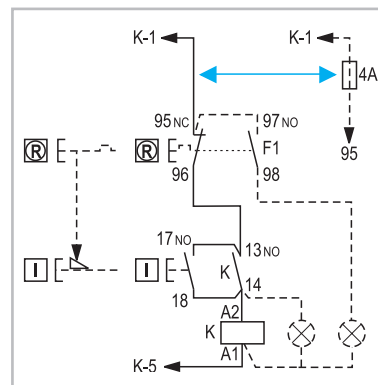

Control by two or more push-buttons

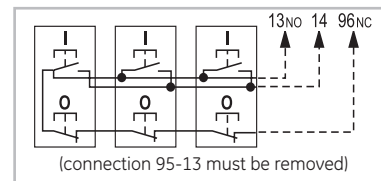

Control by permanent contact

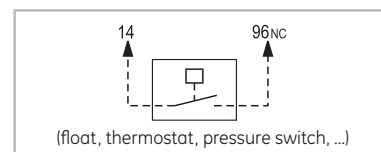

## Wiring diagrams

Intro

A

B

C

D

E

F

G

H

I

J/X



## Wiring diagrams

### Series CK. Direct-on-line starter

#### Power circuit

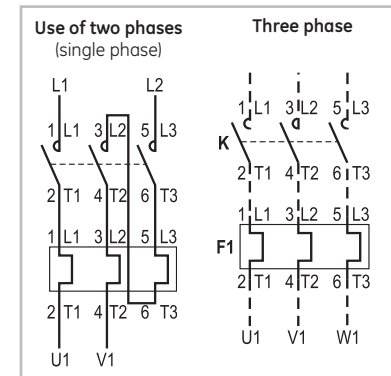

#### Control circuit

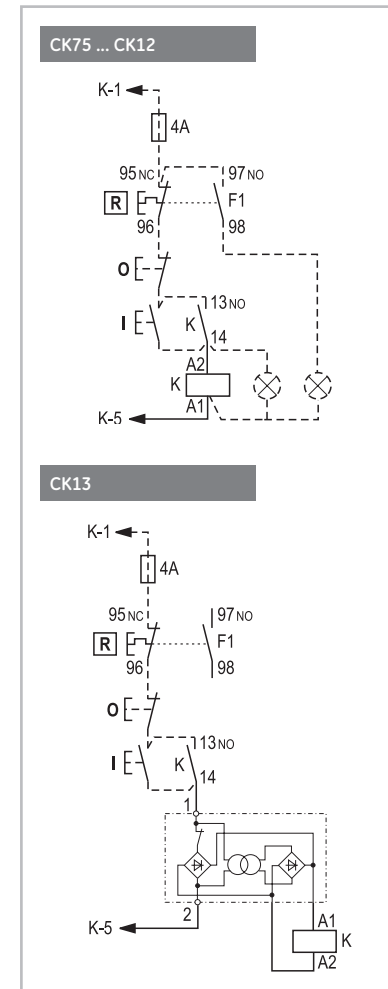

#### Control by two or more push-buttons

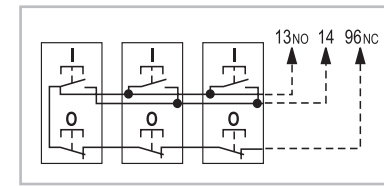

#### Control by permanent contact

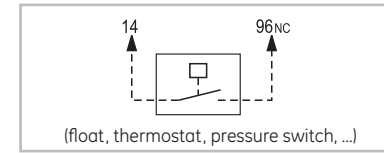

Wiring diagrams

Series CL and CK. Star-delta starters

Power circuit

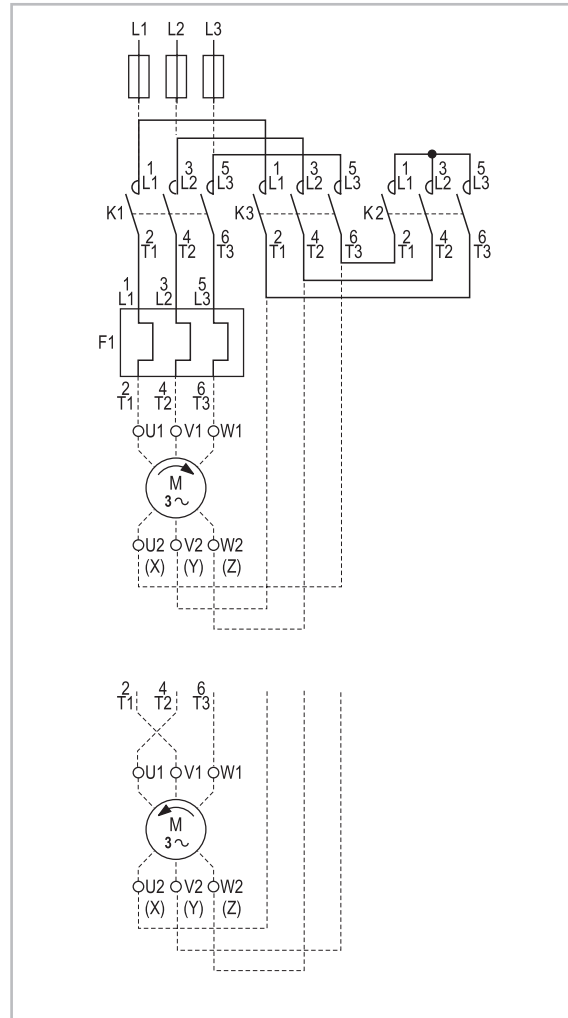

Control circuit

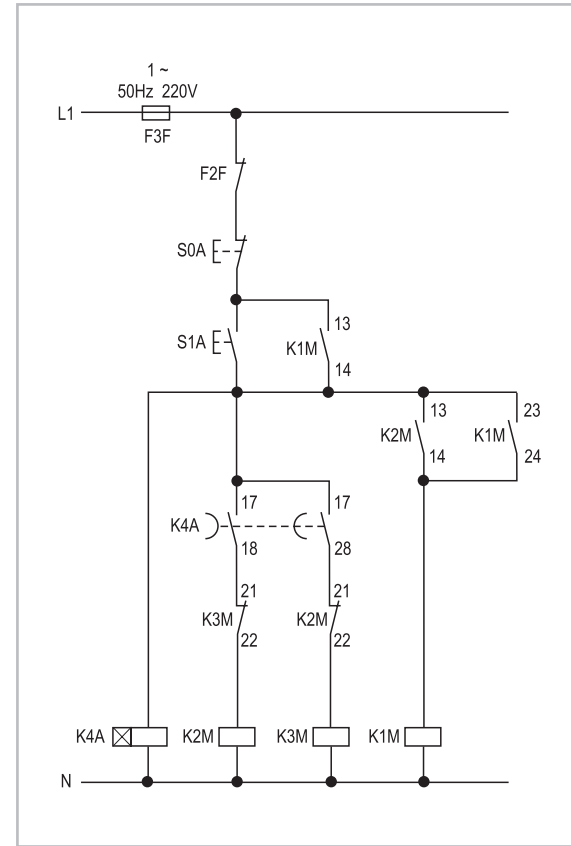

Wiring diagrams

Intro

A

B

C

D

E

F

G

H

I

J/X



Wiring diagrams

Series M. Reversing starter without thermal overload relay

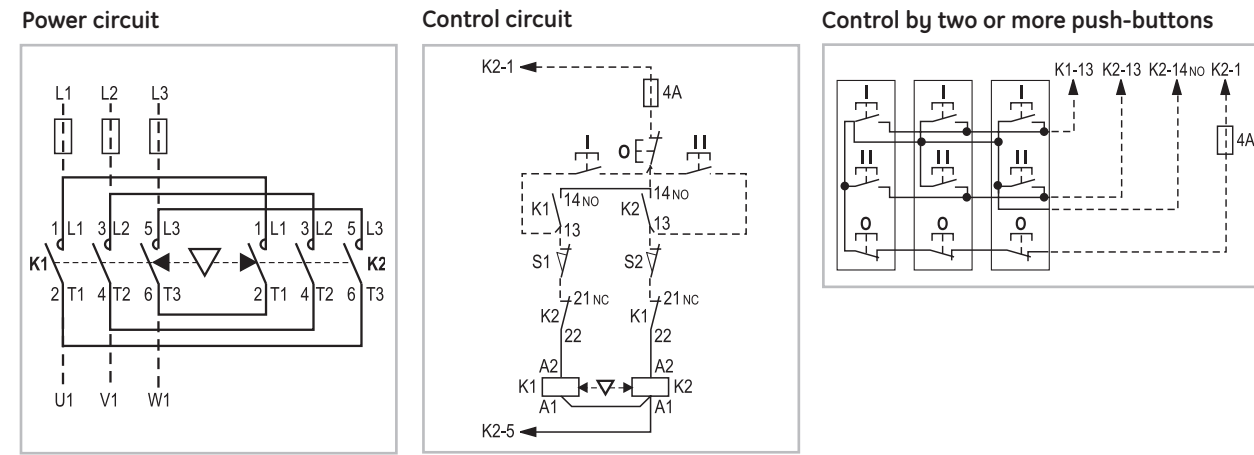

Series CL. Reversing starter without thermal overload relay

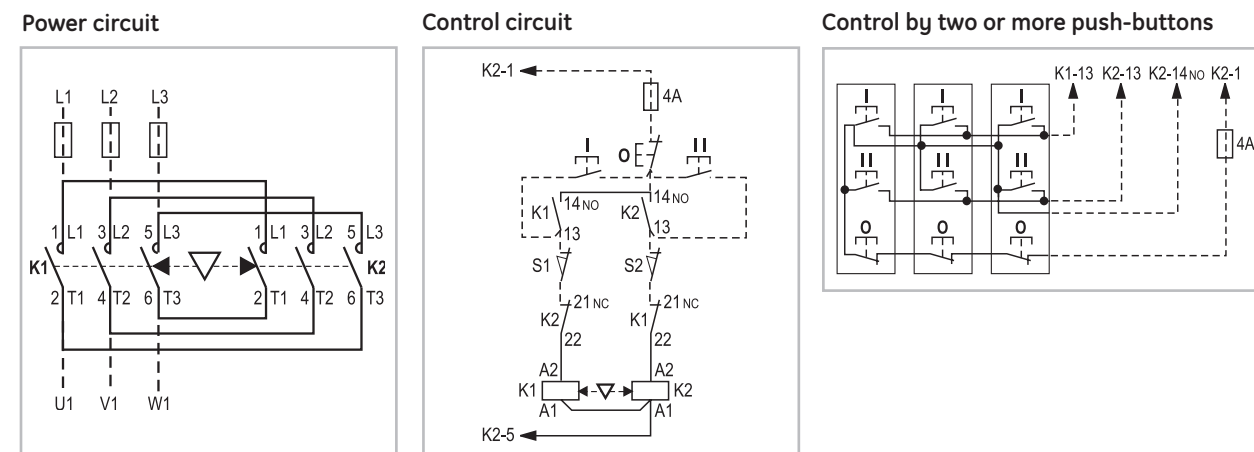

Series CL. Reversing starter with thermal overload relay

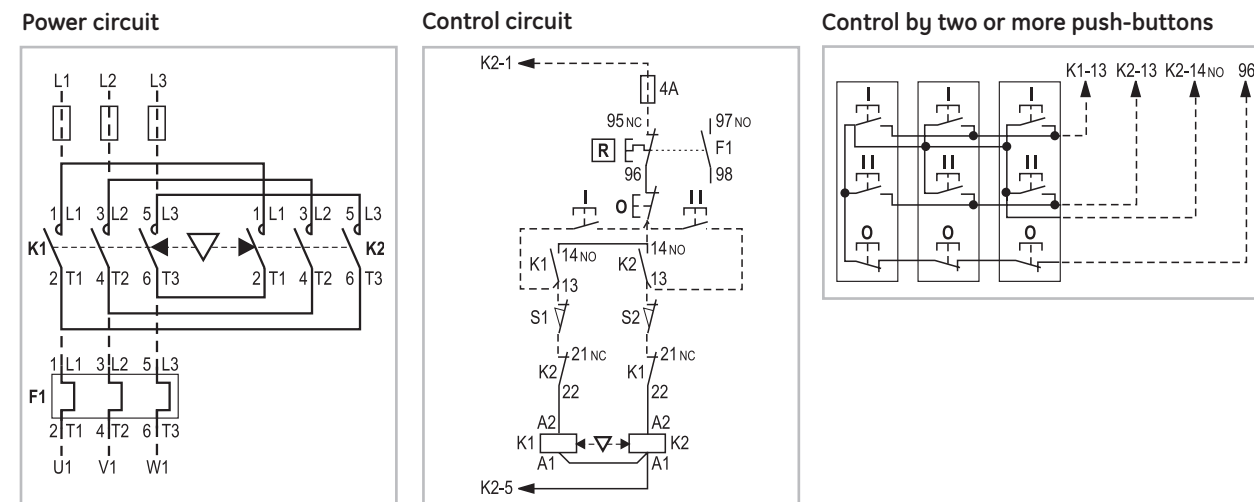



Series CK. Reversing starter without thermal overload relay

Power circuit

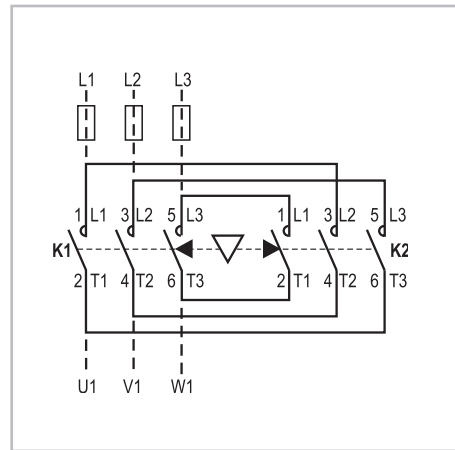

Control by two or more push-buttons

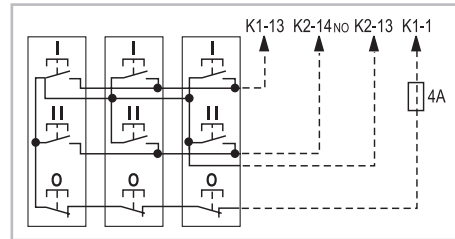

Control circuit

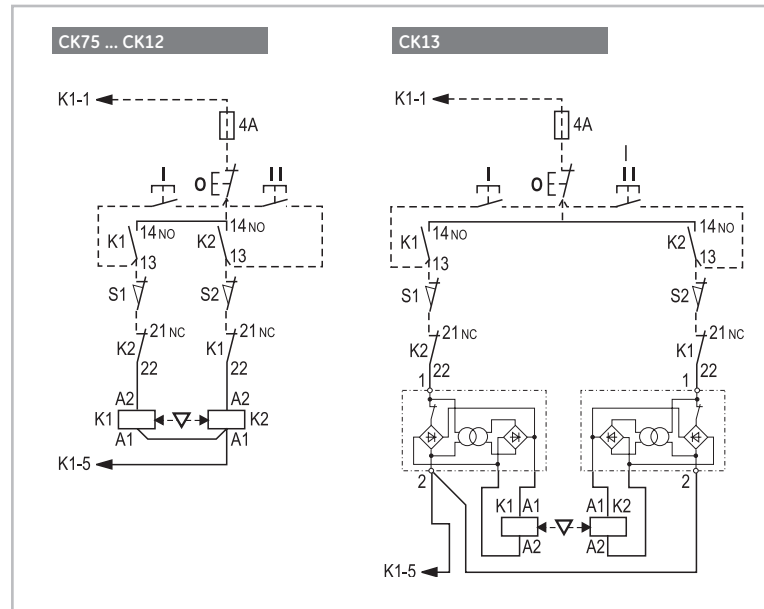

Series CK. Direct-on-line starters with thermal overload relay

Power circuit

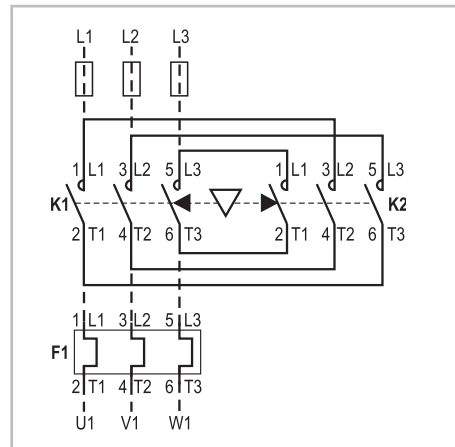

Control by two or more push-buttons

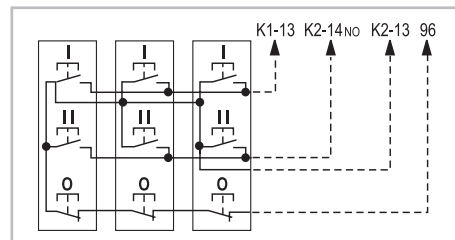

Control circuit

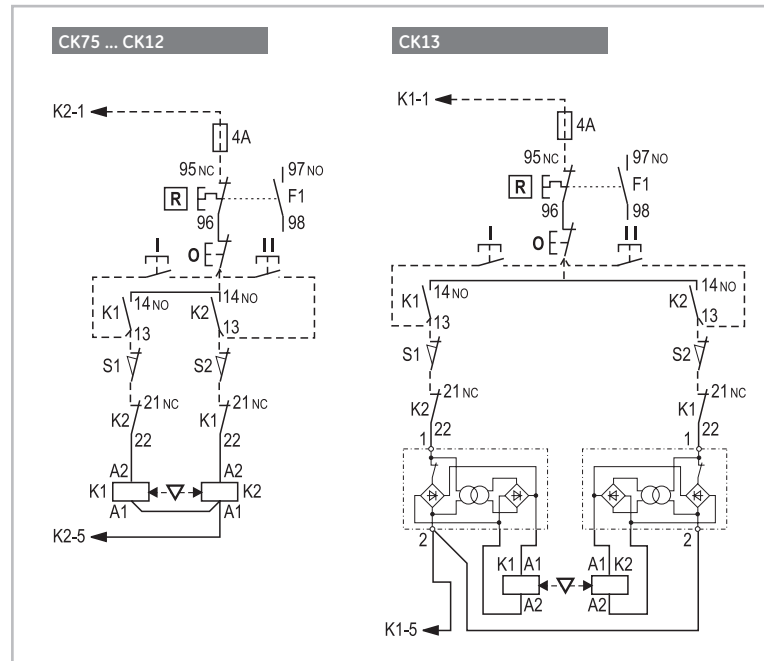

Wiring diagrams

Intro

A

B

C

D

E

F

G

H

I

J/X



Dimensional drawings

Direct-on-line starters. IP40 / IP65

Series M

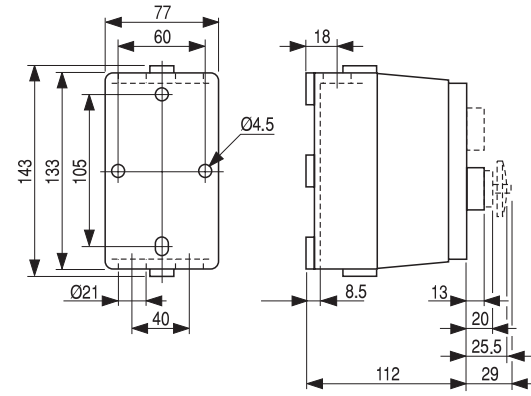

Series CL

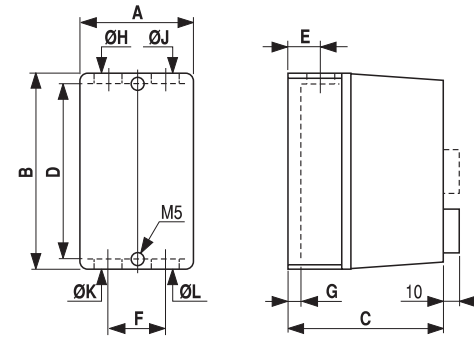

	LG00... - LG02...	LG25... - LG04...
A	87	101
B	180	195
C	124.5	136
D	162	177
E	20	23
F	49	57
G	8	8
Ø H	21	23
Ø J	21	21
Ø K	21	23
Ø L	21	23

Series CL - Direct-on-line starters

CL00 ... CL25

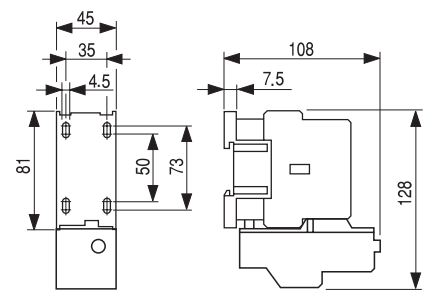

CL04

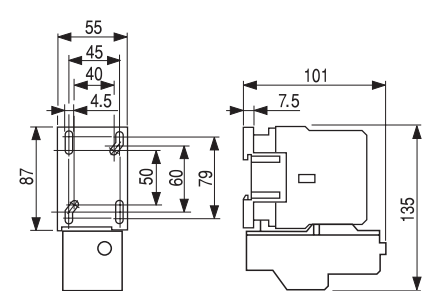

CL45 ... CL08

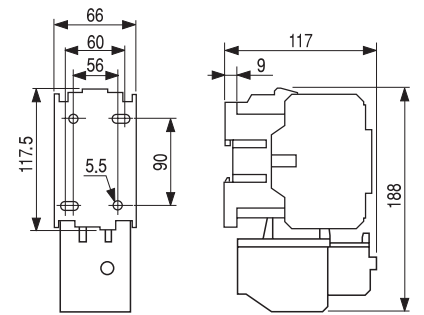

CL09 ... CL10

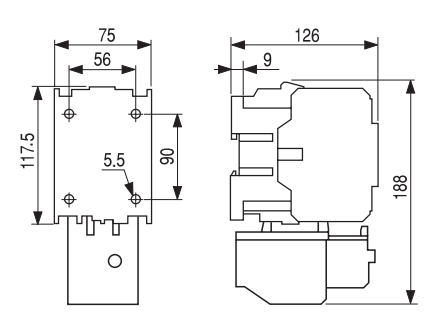

Dimensional drawings

Intro

A

B

C

D

E

F

G

H

I

J/X



## Series CK - Direct-on-line starters

CK75 ... CK08

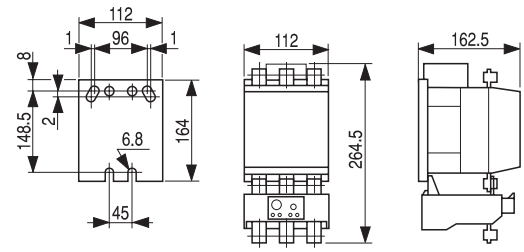

CK85 ... CK95

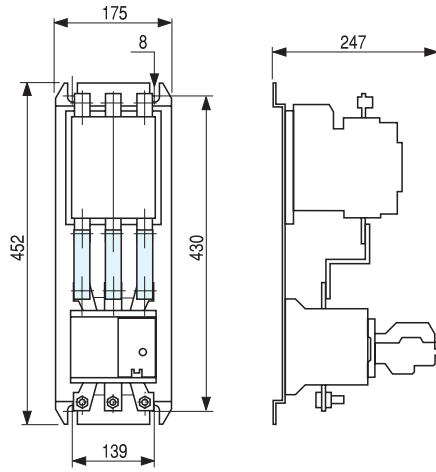

CK10 ... CK11

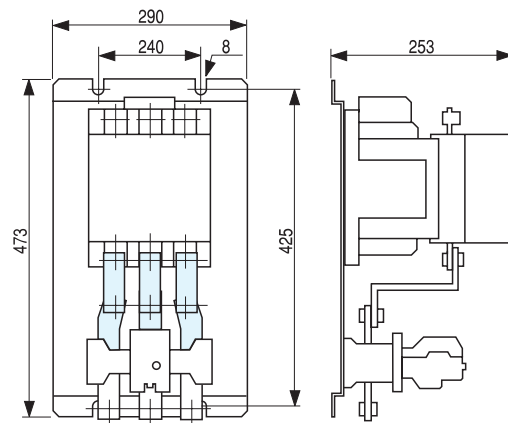

CK12

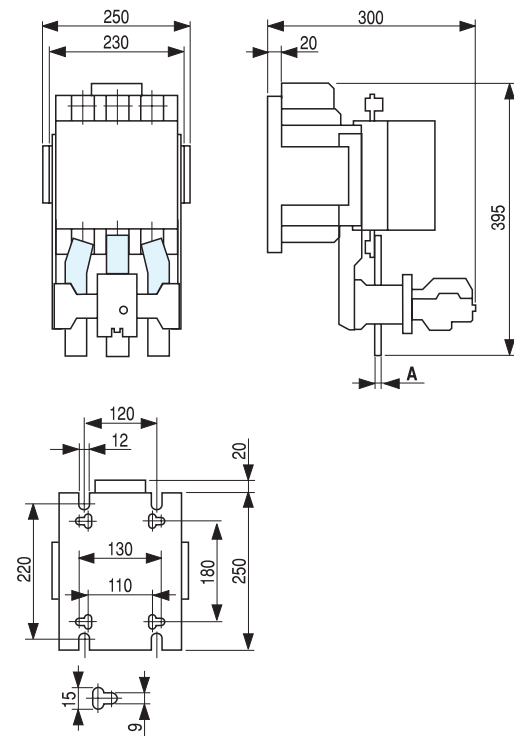

### Dimensions

Intro

A

B

C

**D**

E

F

G

H

I

J/X



Dimensional drawings

Series M. Direct-on-line reversing starters

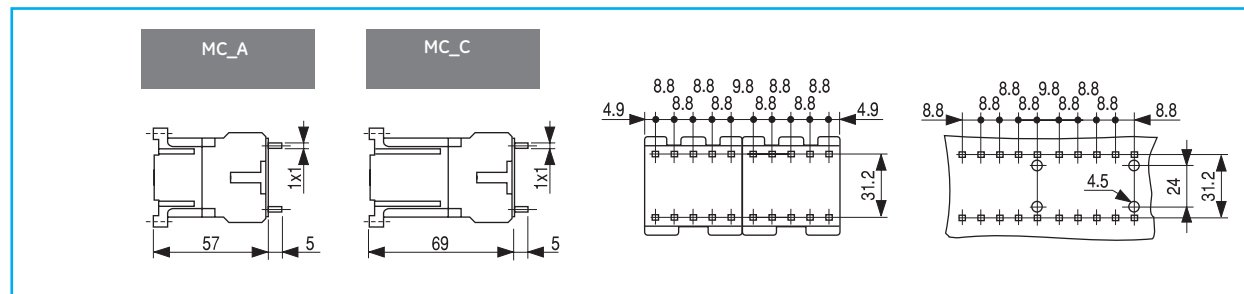
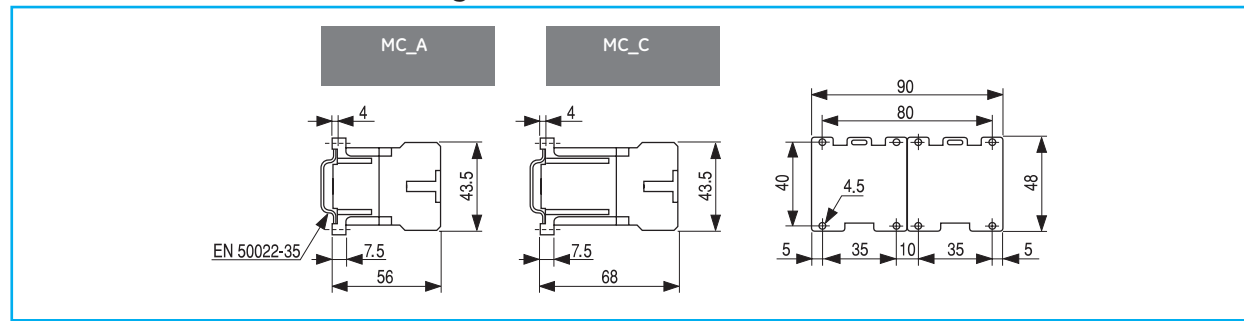

Series CL. Direct-on-line reversing starters without thermal overload relay

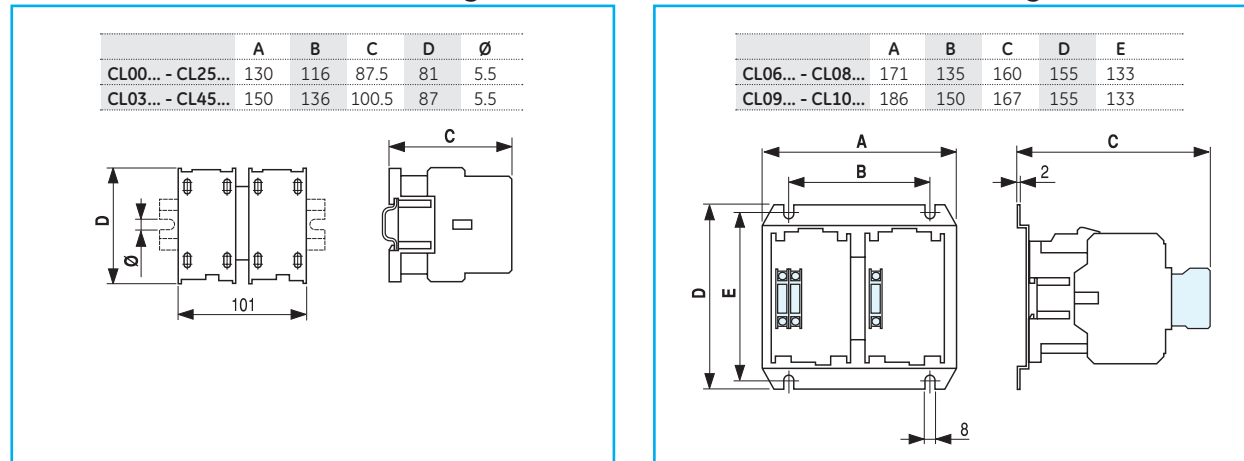

Series CL. Direct-on-line reversing starters with thermal overload relay

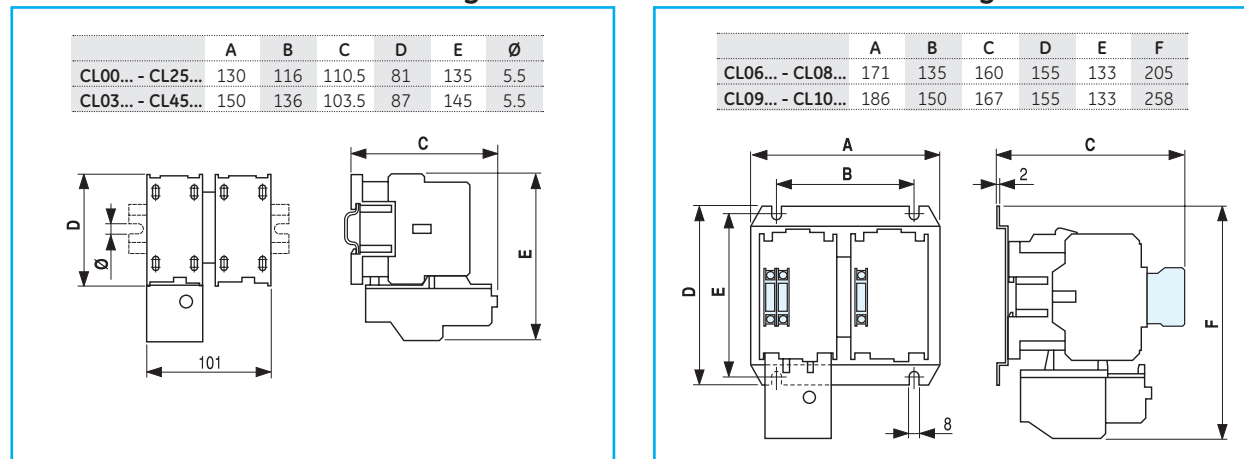

Dimensional drawings

Intro

A

B

C

D

E

F

G

H

I

J/X



**Series CK. Direct-on-line reversing starters without thermal overload relay**

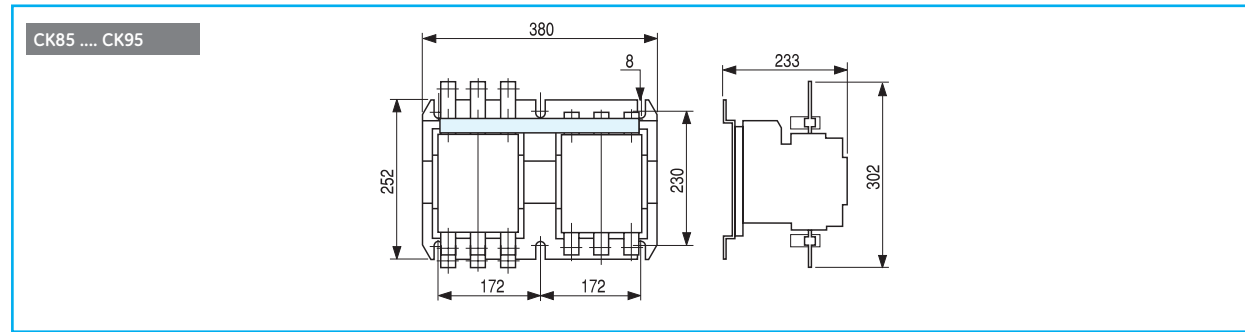
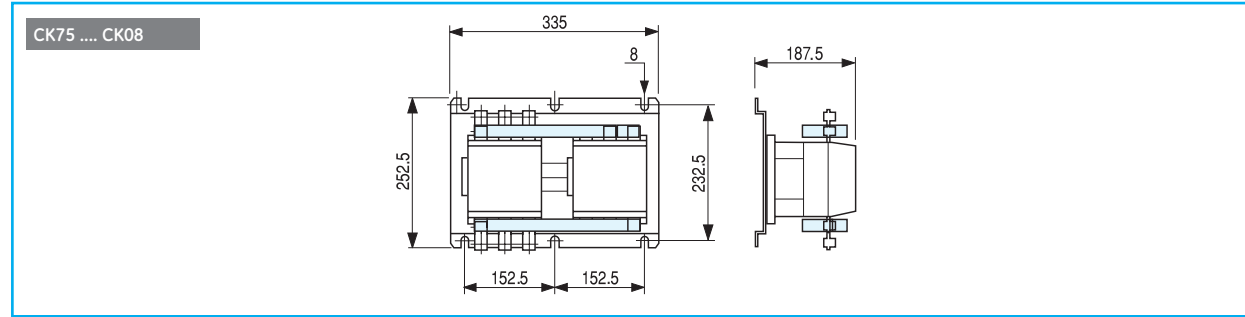

**Series CK. Direct-on-line reversing starters with thermal overload relay**

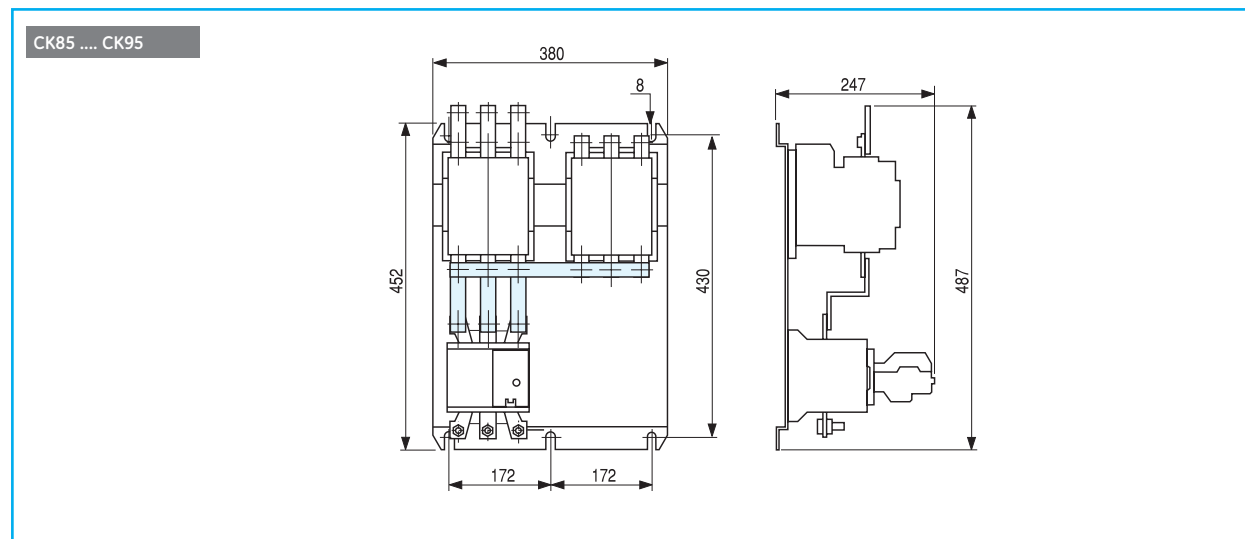
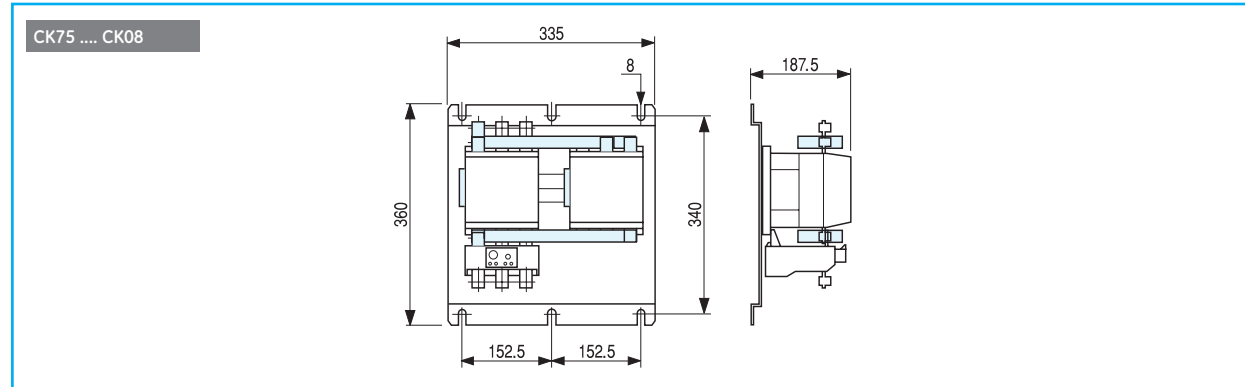

Dimensions

Intro

A

B

C

**D**

E

F

G

H

I

J/X



Dimensional drawings

Series CK - Direct-on-line reversing starters without thermal overload relay

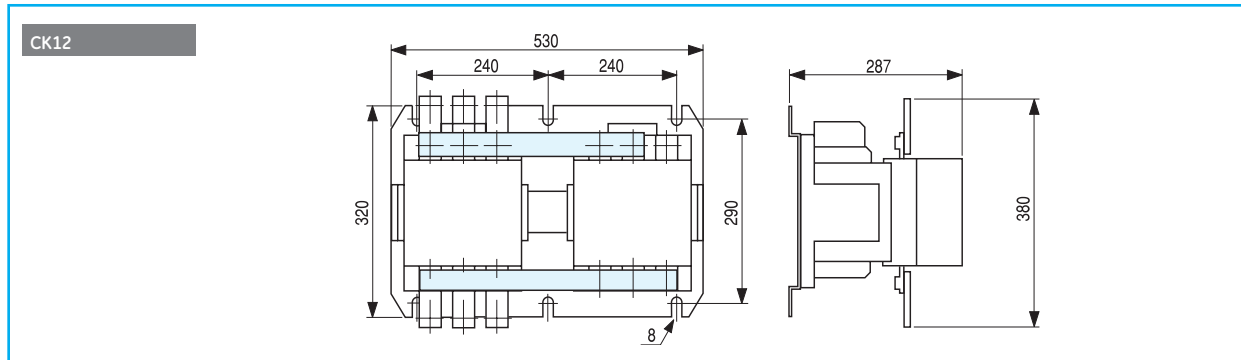
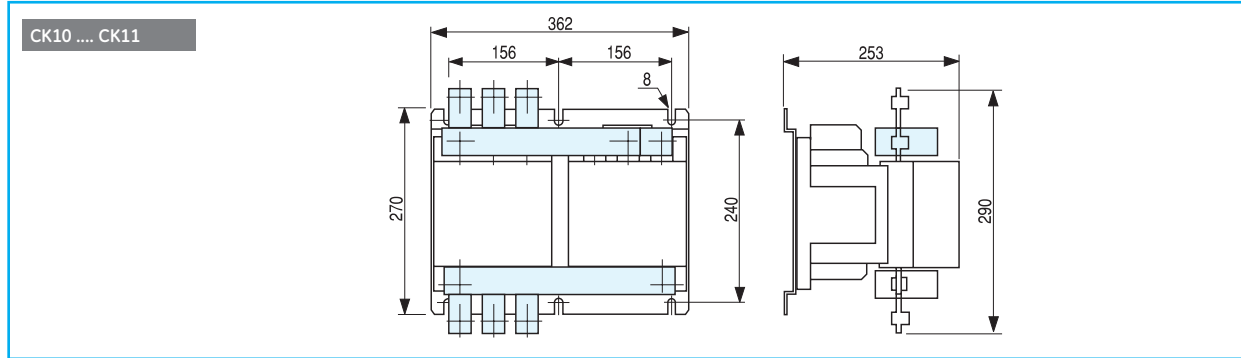

Series CK - Direct-on-line reversing starters with thermal overload relay

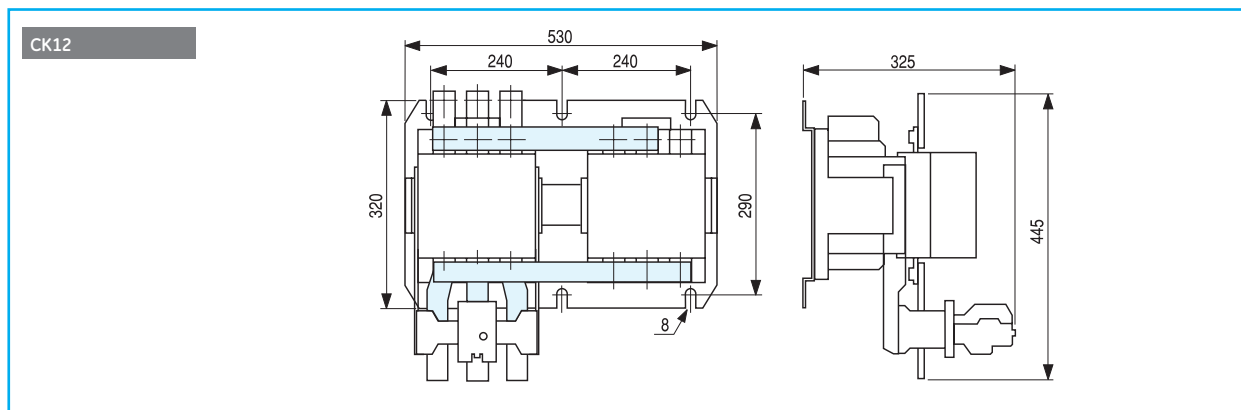
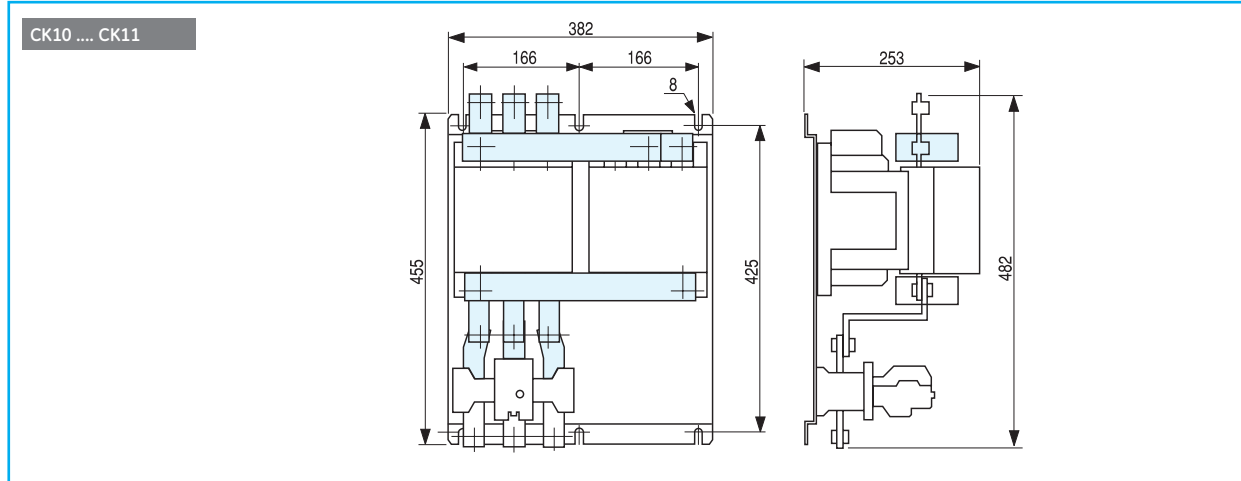

Dimensional drawings

Intro

A

B

C

D

E

F

G

H

I

J/X



Series CL - Star-delta starters

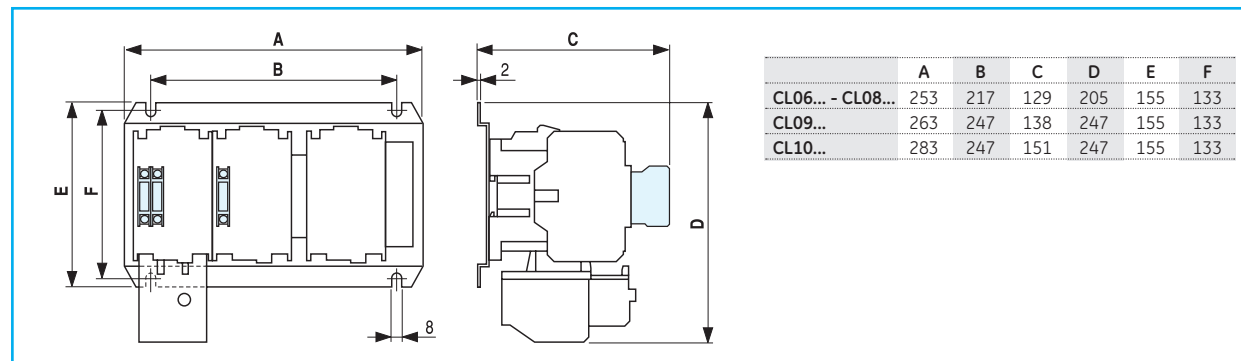
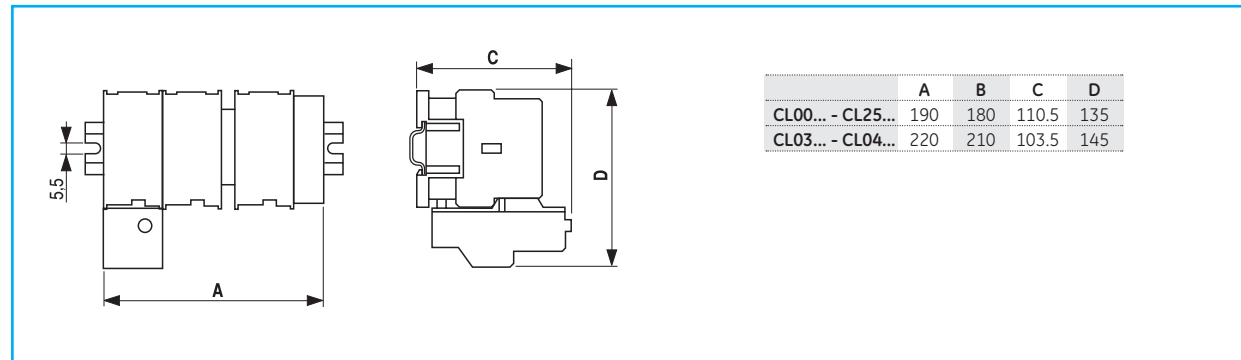

Series CK - Star-delta starters

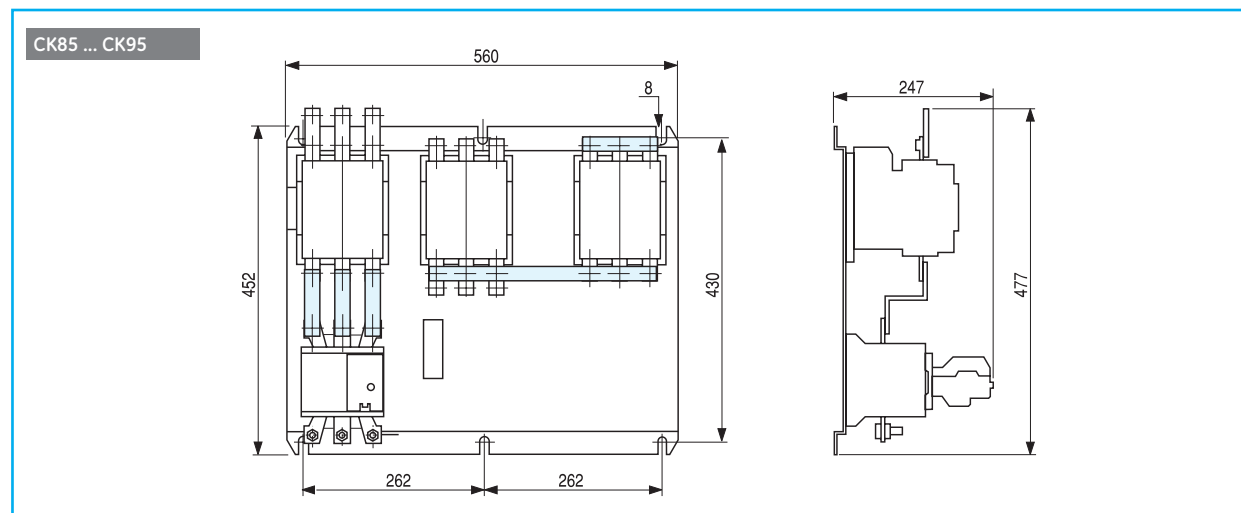
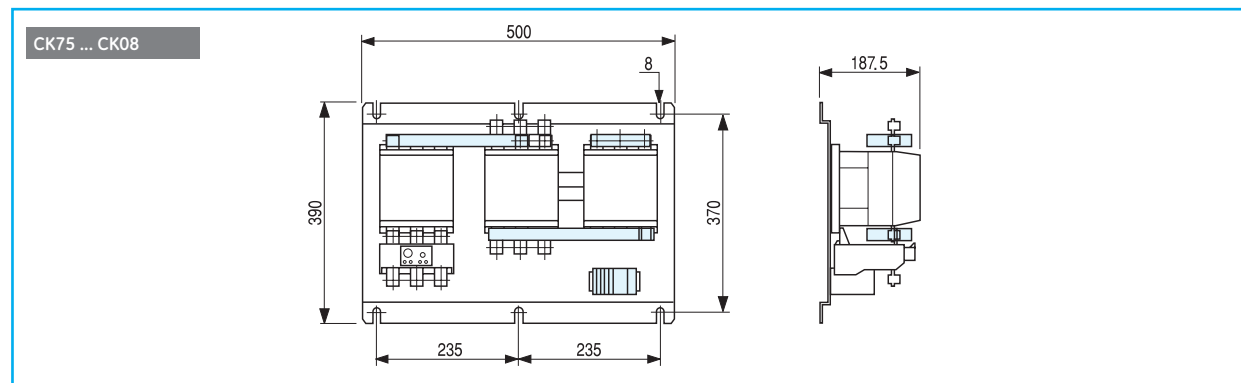

Dimensions

Intro

A

B

C

D

E

F

G

H

I

J/X



Dimensional drawings

Series CK - Star-delta starters

Dimensional drawings

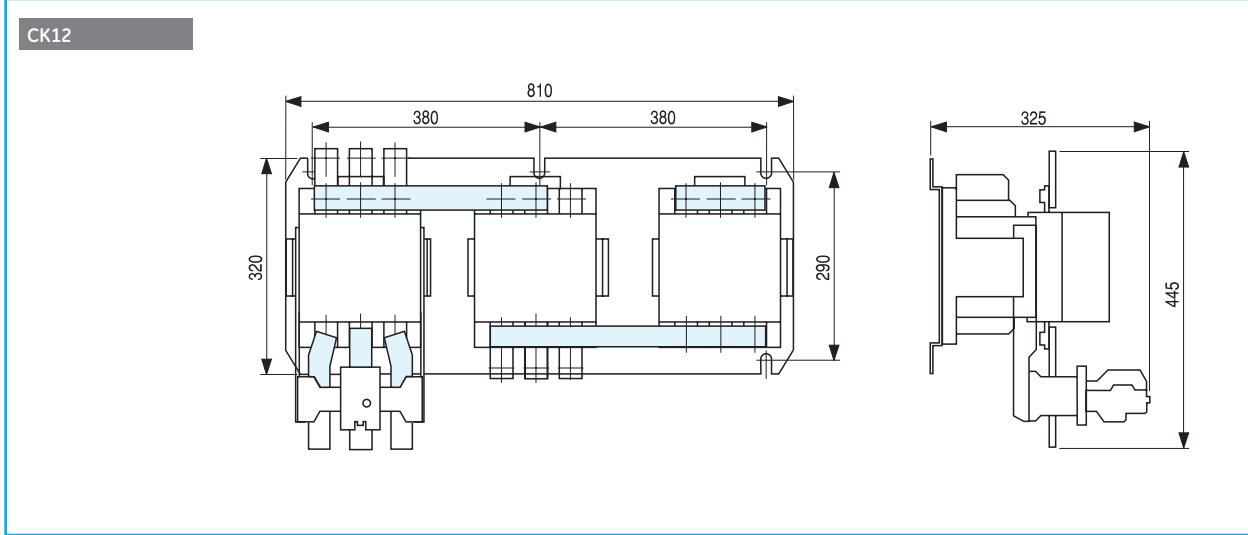
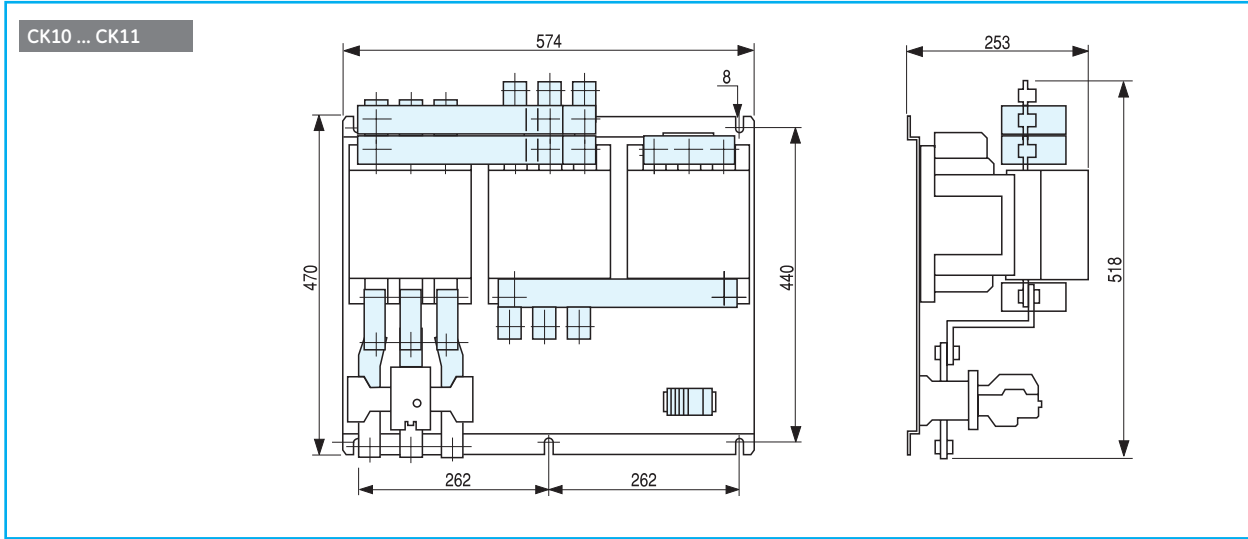

Intro

A

B

C

D

E

F

G

H

I

J/X







<b>Main switches &amp; Emergency-stop switches for machinery - Series ML</b>			Intro
E.3	Mounting possibilities		
E.4	Standard programme	<b>POWER DEVICES</b> Contactors and overload relays	A
E.6	Accessories		
E.7	Enclosed switches	Auxiliary relays and contactors	B
E.8	Technical data		
E.9	Dimensions	Motor protection devices	C
<b>Switches for fotovoltaic application</b>			
E.13	<b>Order codes</b>	Applications	D
E.13	<b>Technical data</b>	<b>Main switches</b>	<b>E</b>
<b>AUXILIARY DEVICES</b> Control and signalling units			F
Electronic relays and limit switches			G
<b>POWER ELECTRONICS</b> Speed drive units			H
Soft starters			I
Lighting dimmer-stabilizer/Numerical index			J/X





### Main switches

A manual operated main switch must be provided for every mains circuit. It must be a switch-disconnector corresponding to utilization category AC23 (IEC 947-3) fulfils the following requirements:

- Disconnecting the electrical equipment from the main.
- Visible contact indication or a disconnection function by construction (the handle is in the "OFF" position when all contacts are open).
- If the main switch does not serve simultaneously as an emergency-stop switch, its handle should not be red. Black or grey handles are recommended.
- It should be lockable in the off-position (e.g. by padlock).
- All active conductors are to be disconnected from the main.
- The breaking capacity should be sufficient. In order to break the current of the largest motor in a blocked state together with the sum of the operating currents of the remaining motors/loads.
- The handle of the main switch must be easily accessible and must lie between 0.6 and 1.9 m above the incomer level.

### Standards

- Complying with:
- IEC 60947-3
  - EN 60947-3
  - DIN VDE 0660 Teil 107
  - low voltage directive 73/73 EEC
  - low voltage directive EMC 89/336 EEC

### Approvals/Marking



### Emergency-stop switches

The main switch may fulfil the function of an emergency-stop switch on certain machines. The handles must be red on a yellow background. The contacts of manual operated emergency-stop switch has to be opened by force.

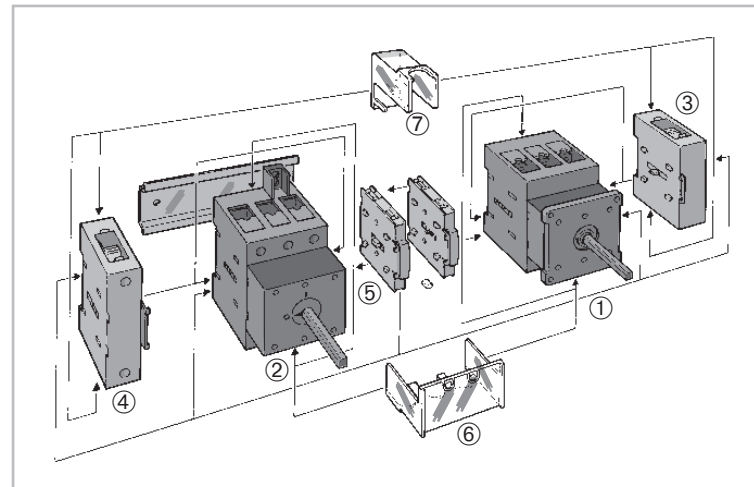

- ① Front mounting (flush mounting)
- ② Rear mounting
- ③ Main contact and PE-or N-terminals for ①
- ④ Main contact and PE-or N-terminals for ②
- ⑤ Auxiliary switch 1NO/1NG for ① and ②
- ⑥ Terminal cover triple for ① and ②
- ⑦ Terminal cover single for ③ and ④

- Mounting possibilities ● pg. E.3
- Accessories ● pg. E.6
- Technical data ● pg. E.8
- Dimensions ● pg. E.9



Mounting possibilities

	lth	25A	40A	63A	80A	125A
Series		ML 1	ML 1	ML 2	ML 2	ML 3
Colour						
<b>Front mounting (flush mounting)</b>						
<b>Central fixing</b>						
Ø 22.5 mm for 3 padlocks	red/yellow	789178	789179			
Ø 22.5 mm for 3 padlocks	black	789180	789181			
Ø 22.5 mm for 1 or 2 padlocks	red/yellow	789174	789175			
Ø 22.5 mm for 1 or 2 padlocks	black	789176	789177			
<b>4-hole fixing</b>						
With standard handle	black	789239	789240	789241	789242	789243
For 3 padlocks	red/yellow	789186	789187	789188	789189	789190
For 3 padlocks	black	789191	789192	789193	789194	789195
For 1 or 2 padlocks	red/yellow	789182	789183			
For 1 or 2 padlocks	black	789184	789185			
<b>Rear mounting</b>						
<b>With cover coupling</b>						
For 3 padlocks	red/yellow	789200	789201	789202	789203	789204
For 3 padlocks	black	789205	789206	789207	789208	789209
For 1 or 2 padlocks	red/yellow	789196	789197			
For 1 or 2 padlocks	black	789198	789199			
<b>With door coupling</b>						
For 3 padlocks	red/yellow	789214	789215	789216	789217	789218
For 3 padlocks	black	789219	789220	789221	789122	789223
For 1 or 2 padlocks	red/yellow	789210	789211			
For 1 or 2 padlocks	black	789212	789213			
<b>DIN-rail mounting</b>						
With standard handle	black	789234	789235	789236	789237	789238
For 1 or 2 padlocks	red/yellow	789224	789225	789226	789227	789228
For 1 or 2 padlocks	black	789229	789230	789231	789232	789233

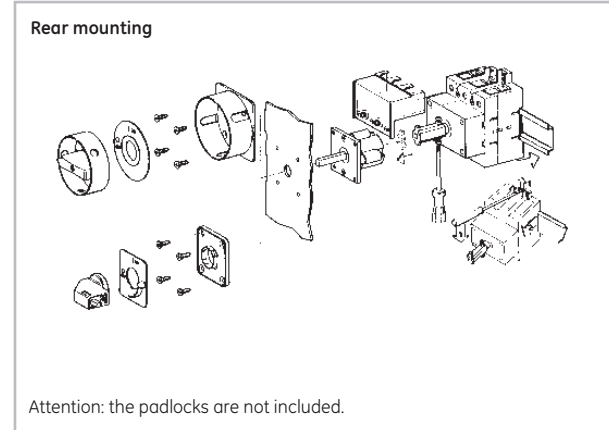
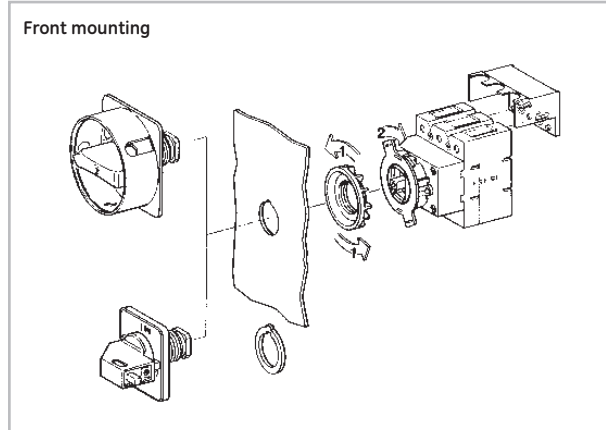

Main switches

Intro

A

B

C

D

E

F

G







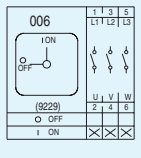

H

I

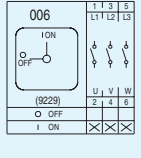
J/X

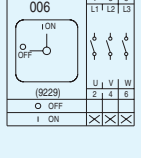

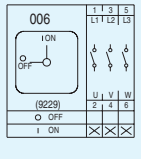
Standard programme

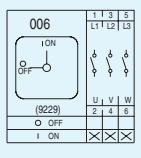
Central fixing Ø 22.5 mm		Diagram	Terminal cover	Protection	Ithe	Red/yellow	Black/gray	Pack
						Ref. no.	Ref. no.	
 <p>Locking handle by 1 or 2 padlocks</p>		✓	IP65	25A	789174	789176	1	
		✓	IP65	40A	789175	789177	1	
 <p>Locking handle by 3 padlocks</p>		✓	IP65	25A	789178	789180	1	
		✓	IP65	40A	789179	789181	1	
4-hole fixing								
 <p>Locking handle by 1 or 2 padlocks</p>		✓	IP55	25A	789182	789184	1	
		✓	IP55	40A	789183	789185	1	
 <p>Locking handle by 3 padlocks</p>		✓	IP55	25A	789186	789191	1	
		✓	IP55	40A	789187	789192	1	
		✓	IP55	63A	789188	789193	1	
		✓	IP55	80A	789189	789194	1	
		✓	IP55	125A	789190	789195	1	
 <p>With standard black handle</p>		-	IP55	25A	-	789239	1	
		-	IP55	40A	-	789240	1	
		-	IP55	63A	-	789241	1	
		-	IP55	80A	-	789242	1	
		-	IP55	125A	-	789243	1	

Accessories see E.6

Main switches

Intro

A

B

C

D

E

F

G







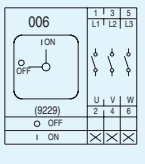

H

I

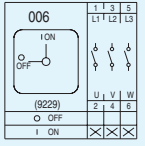
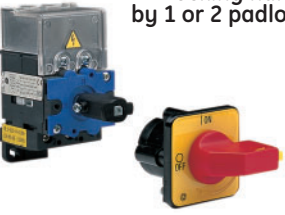
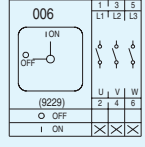
J/X

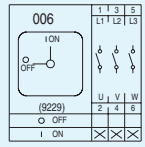

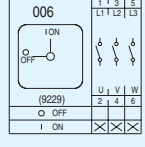
Standard programme

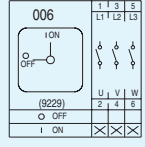
DIN-rail mounting		Terminal cover	Protection	Ithe	Red/yellow Ref. no.	Black/gray Ref. no.	Pack
 <p>Locking handle by 1 or 2 padlocks</p>		✓	IP30	25A	789224	789229	1
		✓	IP30	40A	789225	789230	1
		✓	IP30	63A	789226	789231	1
		✓	IP30	80A	789227	789232	1
		✓	IP30	125A	789228	789233	1
 <p>With standard black handle</p>		-	IP30	25A		789234	1
		-	IP30	40A		789235	1
		-	IP30	63A		789236	1
		-	IP30	80A		789237	1
		-	IP30	125A		789238	1
With door coupling							
 <p>Locking handle by 1 or 2 padlocks</p>		✓	IP55	25A	789210	789212	1
		✓	IP55	40A	789211	789213	1
 <p>Locking handle by 3 padlocks</p>		✓	IP55	25A	789214	789219	1
		✓	IP55	40A	789215	789220	1
		✓	IP55	63A	789216	789221	1
		✓	IP55	80A	789217	789222	1
		✓	IP55	125A	789218	789223	1
With cover coupling							
 <p>Locking handle by 1 or 2 padlocks</p>		✓	IP65	25A	789196	789198	1
		✓	IP65	40A	789197	789199	1
 <p>Locking handle by 3 padlocks</p>		✓	IP65	25A	789200	789205	1
		✓	IP65	40A	789201	789206	1
		✓	IP65	63A	789202	789207	1
		✓	IP65	80A	789203	789208	1
		✓	IP65	125A	789204	789209	1

Accessories see E.6

Main switches

Intro

A

B

C

D

E

F

G

H

I

J/X



Accessories - Contact blocks<sup>(1)</sup>



Neutral switched		
Front	Rear	
789244	789245	1
Series ML1		
789246	789247	1
Series ML2		
789248	789249	1
Series ML3		

Fixed neutral module		
Front	Rear	
789262	789263	1
Series ML1		
789264	789265	1
Series ML2		
789266	789267	3
Series ML3		



Switching contact		
Front	Rear	
789250	789251	1
Series ML1		
789252	789253	1
Series ML2		
789254	789255	1
Series ML3		

Auxiliary contact NO+NC Ith = 16A		
Front	Rear	
789268	789269	1
Series ML1		
789268	789269	1
Series ML2		
789268	789269	1
Series ML3		



PE-terminal (Fixed)		
Front	Rear	
789256	789257	1
Series ML1		
789258	789259	1
Series ML2		
789260	789261	1
Series ML3		

Accessories - Terminal cover



Single terminal cover (HS1)		
Series ML1	789270	1
Series ML2	789271	1
Series ML3	789271	1

Triple terminal cover (HS3)		
Series ML1	789272	1
Series ML2	789273	1
Series ML3	789274	1



Same cover for front or rear mounting

Extension shafts for door coupling



Shaft length	Depth range between door and base (mm)		
	ML1	ML2, ML3	Cat. no.
AL-65	170-215 mm	185-320 mm	789275
AL-165	265-335 mm	280-350 mm	789276
AL-265 <sup>(2)</sup>	365-435 mm	380-450 mm	789277
AL-365 <sup>(2)</sup>	465-535 mm	480-550 mm	789278
Shaft support for 265 and 365 mm			789279

An extension shaft is necessary when the depth is higher than the length of the standard shaft.  
ML1: 105-135 mm  
ML2 and ML3: 120-150 mm

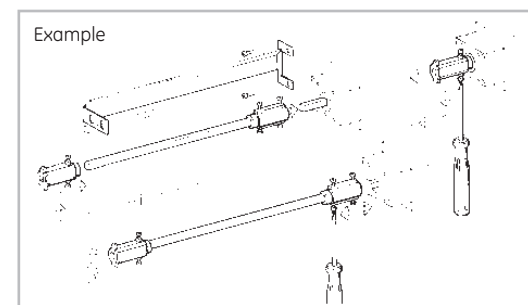

(1) ML1: max. 2 units  
ML2 and ML3: max 3 units  
(2) Shaft support included.



Enclosed switches



The maintenance switch is an enclosed main switch with locking handle by 3 padlocks. With red handle and yellow front plate, if it should be used as an emergency-stop switch, otherwise black/grey. There are six sizes of standard enclosures for the series ML. Each is equipped with a cover coupling and a double PE-terminal. All enclosures have a degree of protection IP65 and are of solid impact and flame resistant polyester.

Enclosed switches

	Diagram	Ithe	Type of enclosure	Black/grey	Red/yellow	Pack.
				3 padlocks	3 padlocks	
				Ref. no.	Ref. no.	
Three poles		25A	E2	789285	789280	1
		32A	E3	789286	789281	1
		50A	E4	789287	789282	1
		63A	E5	789288	789283	1
		100A	E7	789289	789284	1
Four poles		25A	E2	789295	789290	1
		32A	E3	789296	789291	1
		50A	E4	789297	789292	1
		63A	E5	789298	789293	1
		100A	E7	789299	789294	1
Three poles + (1 NO + 1 NC)		25A	E2	789305	789300	1
		32A	E3	789306	789301	1
		50A	E4	789307	789302	1
		63A	E5	789308	789303	1
		100A	E7	789309	789304	1
Four poles + (1 NO + 1 NC)		25A	E2	789315	789310	1
		32A	E3	789316	789311	1
		50A	E4	789317	789312	1
		63A	E5	789318	789313	1
		100A	E7	789319	789314	1
Six poles		25A	E2	789325	789320	1
		32A	E3	789326	789321	1
		50A	E4	789327	789322	1
		63A	E5	789328	789323	1
		100A	E7	789329	789324	1
Six poles + (1 NO + 1 NC)		25A	E2	789335	789330	1
		32A	E3	789336	789331	1
		50A	E4	789337	789332	1
		63A	E5	789338	789333	1
		100A	E7	789339	789334	1

Main switches

Intro

A

B

C

D

E

F

G

H



I

J/X



Technical data

Main switches - According to IEC 60947-3, EN 60947-3, DIN VDE 0660 part 107, UL and CSA

Series			ML 1	ML 1	ML 2	ML 2	ML 3
Rated uninterrupted current	I <sub>u</sub> open = I <sub>th</sub>	(A)	25	40	63	80	125
	I <sub>th</sub> enclosed	(A)	25	32	50	63	100
Rated insulation voltage U <sub>i</sub> (III/3)		(V)	690	690	690	690	690
Rated impulse withstand voltage U <sub>imp</sub> (III/3)		(kV)	6	6	6	6	6
Rated operational current I <sub>e</sub> AC21 A <sup>(1)</sup>		(A)	25	40	63	80	125
Rated operational voltage U <sub>e</sub>		(V)	690	690	690	690	690
Frequency		(Hz)	50/60	50/60	50/60	50/60	50/60
<b>Making/breaking capacity</b>							
Utilization category AC3:	3 x 230V	(kW)	5.5	7.5	15	18.5	22
Motor switches for	3 x 400V	(kW)	7.5	11	22	30	37
operational switching	3 x 690V	(kW)	7.5	11	22	30	45
Utilization category AC23A <sup>(2)</sup>	3 x 230V	(kW)	7.5	11	18.5	22	25
Motor switches	3 x 400V	(kW)	11	15	30 <sup>(1)</sup>	37 <sup>(2)</sup>	45
(Main switches for machinery)	3 x 690V	(kW)	11	15	30 <sup>(1)</sup>	37 <sup>(2)</sup>	45
Rated breaking category AC23 A <sup>(3)</sup>	3 x 230V	(A)	260	390	630	750	870
	3 x 400V	(A)	220	300	570	700	850
	3 x 690V	(A)	130	170	330	400	490
<b>Short-circuit capacity</b>							
Max. fuse rating gG		(A)	50	50	80	80	125
Rated conditional short-circuit current		(kA <sub>eff</sub> )	10	10	-	-	-
Rated short-circuit making capacity I <sub>cm</sub>		(kA)	-	-	2.1	2.1	3.4
Rated short-time withstand I <sub>cs</sub> (1s-current)		(A <sub>eff</sub> )	300	480	765	960	1500
Disconnect function up to		(V)	690	690	690	690	690
Terminal screws (Pozidriv)			M4	M4	M5	M5	M6
Torque terminal screws		(Nm)	2.5	2.5	4	4	6
<b>Cable cross section</b>							
Solid or multi-stranded (Cu)	min. - max. (mm <sup>2</sup> )		1.5-10	1.5-10	2.5-35	2.5-35	6-70
Flexible with ferrule (DIN 46228)	min. - max. (mm <sup>2</sup> )		1.5-6	1.5-6	1.5-25	1.5-25	6-50
General purpose 3-phase		(A)	25	40	63	80	125
		(V)	600	600	600	600	600
 Motor 3-phase	240V	(HP)	7.5	10	15	20	25
	480V	(HP)	10	20	30	40	50
	600V	(HP)	10	20	30	40	50
 Motor 1-phase (2 pole)	120V	(HP)	1	1.5	3	4	6
	240V	(HP)	2	3	7.5	10	15
Cable cross section	AWG-No		14-7	14-3	14-2	14-2	8-1/0

(1) 22 kW in enclosure  
 (2) 30 kW in enclosure  
 (3) ML2/ML3 according to EN 60947-3 category B

Auxiliary contact for main switches - According to IEC 60947-5-1

Series			ML 1/2/3		
Rated uninterrupted current	I <sub>u</sub> open = I <sub>th</sub>	(A)	16		
	I <sub>th</sub> enclosed	(A)	16		
Rated insulation voltage U <sub>i</sub> (III/3)		(V)	690		
Rated impulse withstand voltage U <sub>imp</sub>		(kV)	6		
Rated operational current	I <sub>e</sub> (AC15)				
	230V	(A)	6		
	400V	(A)	4		
	690V	(A)	2		
Max. fuse rating gG		(A)	16		
Rated conditional short-circuit current		(kA <sub>eff</sub> )	3		
Cable cross section, solid or multi-stranded	min. - max. (mm <sup>2</sup> )		1-4		
Flexible with ferrule (DIN 46228)	min. - max. (mm <sup>2</sup> )		1-2.5		
Terminal screws (Pozidriv)			M3		
Torque terminal screws		(Nm)	0.6		

Main switches

Intro

A

B

C

D

E

F

G

H

I

J/X





Dimensional drawings

Front mounting - Central fixing  $\varnothing$  22.5 mm

For 1 or 2 padlocks,  $\varnothing$  max. 5 mm

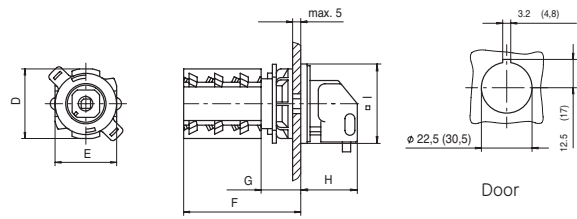

Series	D	E	F	G	H	I
ML1	55	45	75	25	35	48

For 3 padlocks,  $\varnothing$  max. 9 mm

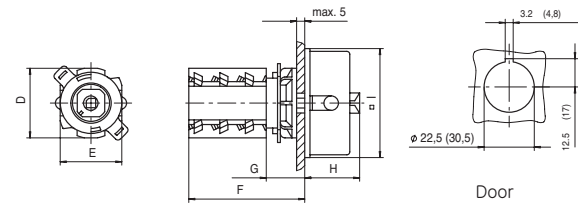

Series	D	E	F	G	H	I
ML1	55	45	75	25	35	66

Front mounting - 4-hole fixing

For 1 or 2 padlocks,  $\varnothing$  max. 5 mm

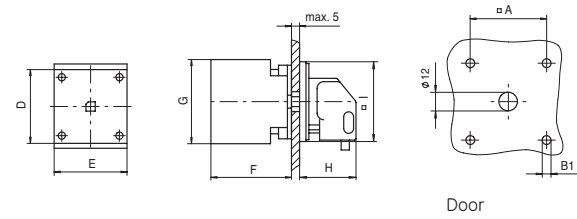

Series	A	B1	D	E	F	G	H	I
ML1	36	4.5	44	44	50	55	35	48

For 3 padlocks,  $\varnothing$  max. 5 mm

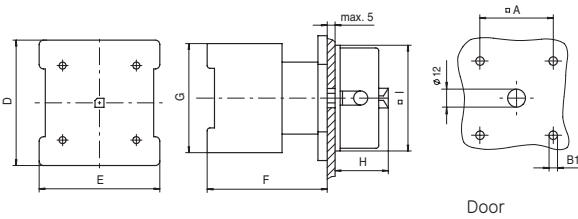

Series	A	B1	D	E	F	G	H	I
ML1	36	4.5	44	44	50	55	32	66
ML2	48	5.5	58	58	72	75	37	86
ML3	48	5.5	78	78	72	80	37	86

Front mounting - 4-hole fixing, with standard black handle

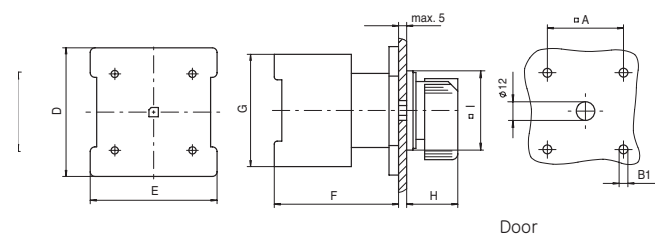

Series	A	B1	D	E	F	G	H	I
ML1	36	4.5	44	44	50	55	29	48
ML2	48	5.5	58	58	72	75	33	64
ML3	69	5.5	78	78	72	80	35	88

Dimensions

Intro

A

B

C

D

E

F

G

H

I

J/X



Dimensional drawings

Rear mounting - DIN-rail mounting

With standard black handle

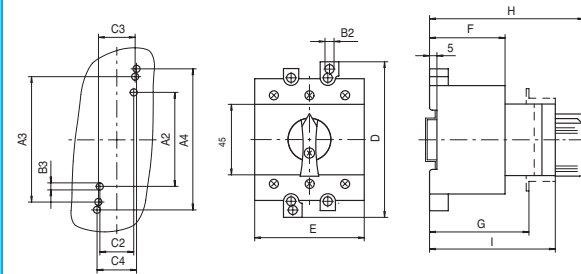

Series	A2	A3	A4	B2	B3	C2	C3
ML1	60	65	70	4.2	3.8	22	30
ML2	-	80	90	5.5	5.2	-	23.5
ML3	-	80	90	5.5	5.2	-	23.5

Series	C4	D	E	F	G	H	I
ML1	25	78	52.5	42	48.5	87.5	67.5
ML2	25	100	53.5	49	-	100	79
ML3	25	100	70	49	-	100	79

For 1 or 2 padlocks, Ø max. 5 mm

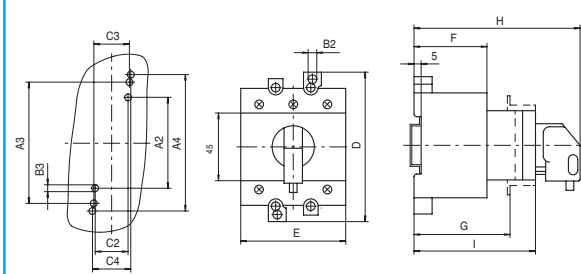

Series	A2	A3	A4	B2	B3	C2	C3
ML1	60	65	70	4.2	3.8	22	30
ML2	-	80	90	5.5	5.2	-	23.5
ML3	-	80	90	5.5	5.2	-	23.5

Series	C4	D	E	F	G	H	I
ML1	25	78	52.5	42	48.5	91.5	67.5
ML2	25	100	53.5	49	-	104	79
ML3	25	100	70	49	-	104	79

Rear mounting - With door coupling

For 1 or 2 padlocks, Ø max. 5 mm

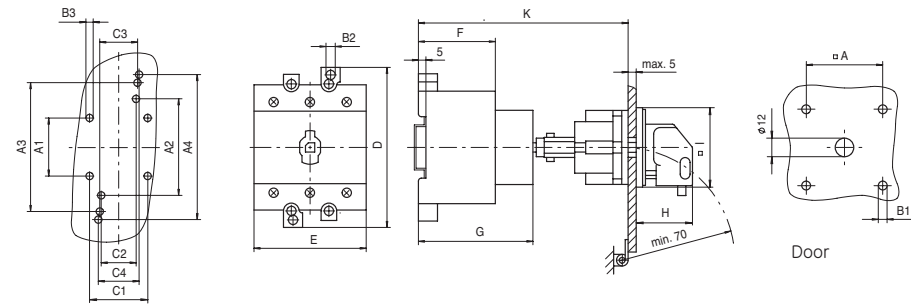

Series	A	A2	A3	A4	B1	B2	B3	C2	C3	C4	D	E	F	G	H	I	K
ML1	36	60	65	70	4.5	4.2	3.8	22	30	25	78	45	42	55	35	48	105-135

For 3 padlocks, Ø max. 5 mm

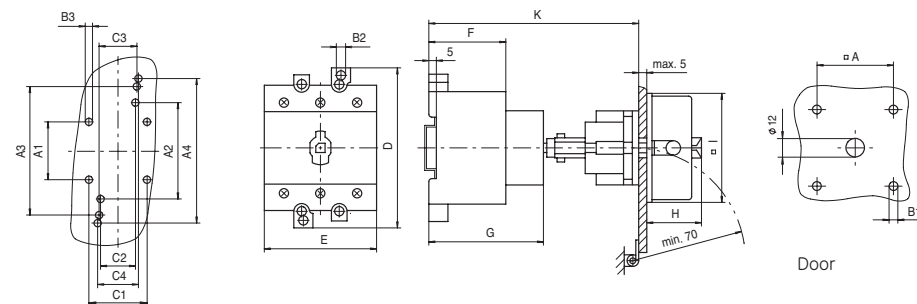

Series	A	A2	A3	A4	B1	B2	B3	C2	C3	C4	D	E	F	G	H	I	K
ML1	36	60	65	70	4.5	4.2	3.8	22	30	25	78	45	42	55	32	66	105-135
ML2	36	-	80	90	5.5	5.5	5.2	-	23.5	25	100	53.5	49	72	37	86	120-150
ML3	36	-	80	90	5.5	5.5	5.2	-	23.5	25	100	70	49	72	37	86	120-150

Rear mounting - With cover coupling

For 1 or 2 padlocks, Ø max. 9 mm

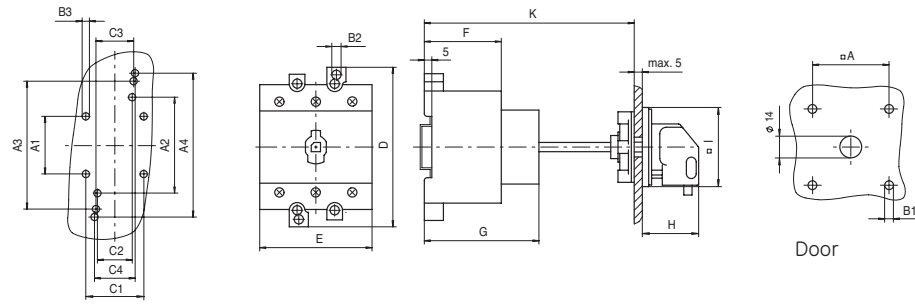

Series	A	A2	A3	A4	B1	B2	B3	C2	C3	C4	D	E	F	G	H	I	K
ML1	36	60	65	70	4.5	4.2	3.8	22	30	25	78	45	42	55	35	48	105-135

For 3 padlocks, Ø max. 9 mm

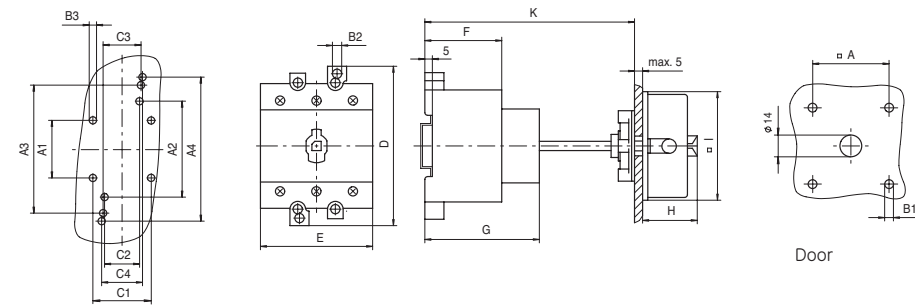

Series	A	A2	A3	A4	B1	B2	B3	C2	C3	C4	D	E	F	G	H	I	K
ML1	36	60	65	70	4.5	4.2	3.8	22	30	25	78	45	42	55	32	66	88-98
ML2	36	-	80	90	5.5	5.5	5.2	-	23.5	25	100	53.5	49	72	37	86	103-113
ML3	36	-	80	90	5.5	5.5	5.2	-	23.5	25	100	70	49	72	37	86	103-113

Enclosed switches

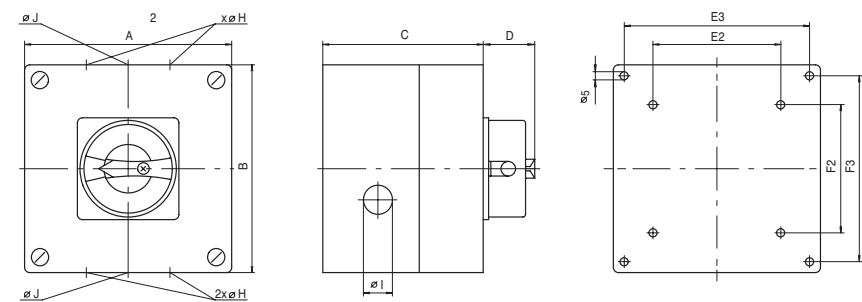

Enclosure Type	A	B	C	D	E2	E3	F2	F3
E2	94	130	81	32	-	79	-	115
E3	130	130	99	32	-	115	-	115
E4	110	180	11	32	50	95	120	165
E5	180	182	111	37	120	165	120	167
E6	180	254	111	37	120	165	190	239
E7	265	265	140	37	194	-	230	-

Cable entry Type	H (1)	I (1)	H (2)	I (2)	J (2)
E2	PG 16/11	PG 11	-	-	-
E3	PG 21/16	PG 16	-	-	-
E4	-	-	PG 21	PG 11	-
E5	-	-	PG 29	-	PG 11
E6	-	-	PG 29	PG 11	-
E7	PG 36/29	PG 29	-	-	-

(1) Knock-out entry  
(2) Cable entry

Dimensions

Intro

A

B

C

D

E

F

G

H

I

J/X



Dimensional drawings

Accessories

**N-module and PE-terminal**

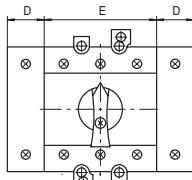

Series	D	E
ML1	14.5	45
ML2	23	53.5
ML3	23	70

**Auxiliary contacts (NO + NC)**

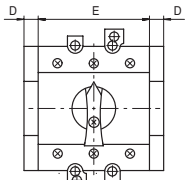

Series	D	E
ML1	9.5	45
ML2	9.5	53.5
ML3	9.5	70

**Terminal covers**

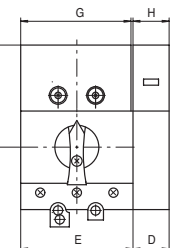

Series	D	E	F	G	H
ML1	14.5	45	53	41	14
ML2	23	53.5	61	52	22.5
ML3	23	70	65	68	22.5

Main switches

- Intro
- A
- B
- C
- D
- E
- F
- G
- H
- I
- J/X





### Switches for photovoltaic applications up to 1000Vdc

To isolate the solar panels from the inverter, from 16 to 100Adc

- Available in 600 and 1000Vdc
- Easy installation, ready to install
- Pre-wired for DC applications
- Compact size
- DIN rail mounting as standard, other configurations possible
- Clear identification of inputs and outputs
- Padlockable

#### Approvals/Marking



#### Technical data/Order codes

According IEC 60947-3	Ref. no.	Ref. no.						
		247532	247533	247534	817600	247536	247537	247538
Rated operational voltage Ue (+10%) (Vdc)		600	600	600	1000	1000	1000	1000
Rated impulse withstand voltage Uimp (kV)		6	6	6	6	6	6	6
Rated thermal current, DC-20 Ith (Adc)		16	25	40	40	63	80	100
In open air, normal conditions[1]								
Minimum cable or bar cross section - Cu (mm²)		2.5	6	10	10	35	35	35
Rated operational current								
600Vdc (Adc)		16	25	40	-	-	-	-
1000Vdc (Adc)		-	10	25	40	63	80	100
Power loss / Pole (W)		1.5	1.5	1.5	1.5	4.5	5.5	3
Number of poles		2	3	3	6	8	8	8
Mechanical service life (Ops)		30,000	30,000	30,000	30,000	30,000	30,000	30,000
Dimensions (HxWxD) (mm)		78x46x55	78x46x55	78x46x55	78x97x55	100x90x73	100x105x73	100x105x73
Frontcover		included	included	included	included	not available	not available	not available

#### Enclosed DC switch without surge protection

Description	Ref. no.	Pack.
Enclosure to protect DC entry at PV inverter level (1 for each inverter) Enclosure IP65 (130 x 130 x 100 mm) DC switch 40A under 600Vdc Clear identification of inputs/outputs DC connectors, type MC-4	817590	1



Main switches

Intro

A

B

C

D

**E**

F

G

H

I

J/X



Notes

A large grid of dotted lines for taking notes, spanning the width of the page and most of its height.

Main switches

Intro

A

B

C

D

E

F

G

H

I

J/X





			Intro
<b>Series P9</b>	<b>POWER DEVICES</b>	Contactor and overload relays	A
F.2 Control and signalling units Ø 22 mm		Auxiliary relays and contactors	B
<b>Series 077</b>		Motor protection devices	C
F.40 Control and signalling units Ø 30 mm		Applications	D
<b>Series 105</b>		Main switches	E
F.57 Signalling devices		<b>Control and signalling units</b>	<b>F</b>
<b>Series NLT</b>	<b>AUXILIARY DEVICES</b>	Electronic relays and limit switches	G
F.62 Light towers		<b>POWER ELECTRONICS</b>	H
<b>Series IP</b>		Speed drive units	I
F.68 Foot switches		Soft starters	J/X
		Lighting dimmer-stabilizer/Numerical index	





- F.3 **Main features**
- F.4 **Range overview**
- F.6 **Technical data**
- F.8 **Order codes - Panel mounting devices**
- F.8 Complete devices
- F.9 Toggle switches - Joysticks
- F.11 Standard push-buttons
- F.11 Mushroom head push-buttons
- F.11 Push buttons with key
- F.12 Selector switches with knob
- F.13 Selector switches with lever
- F.14 Selector switches with key
- F.16 Illuminated push-buttons
- F.16 Illuminated selector switches
- F.17 Selector push-buttons
- F.18 Emergency lever
- F.18 Reset push buttons
- F.18 Potentiometer operators
- F.18 Buzzers - Pilot lights
- F.19 Double function push-buttons
- F.20 Contact blocks
- F.21 Power supplies
- F.22 Electrical diagrams
- F.23 **Order codes - Base mounting devices**
- F.23 Contact blocks and power supplies
- F.24 **Order codes - Push-button stations in thermoplastic**
- F.25 **Order codes - Equipped boxes**
- F.27 **Order codes - Push-button stations in aluminium**
- F.28 **Order codes - Common accessories**
- F.34 **Overall dimensions**
- F.34 Panel mounting
- F.39 Enclosures for push-button stations

Intro

A

B

C

D

E

**F**

G

H

I

J/X





## Main features

### Shape, material and colours



The P9 line offers three types of operators:

- round in satin chrome
- round in engineering thermoplastic
- square in engineering thermoplastic

Modern ergonomic P9 actuators are available in a wide variety of colours and styles, and are the result of superior industrial design experience.

Series P9 satisfies any sophisticated industrial applications.

### Fitting and positioning

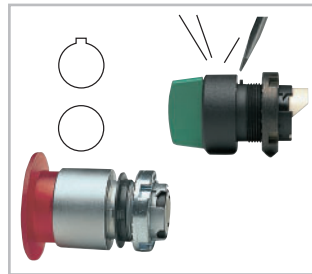

All the P9 operators are fitted with seal to ensure IP66 degree of protection.

A locating tab on the operator allows the correct positioning on panels with holes drilled according to CENELEC EN 50007 standards (with notch). The tab also ensures panel stability and prevents unwanted rotations.

The tab can be removed with a screwdriver for applications in holes without notch.

### Rear locking and back mounting procedure



P9 operators are back mounted to the panel by a patented locking ring. The units can be assembled using a standard screwdriver.

As an option, an assembly wrench is available.

### Fast mounting

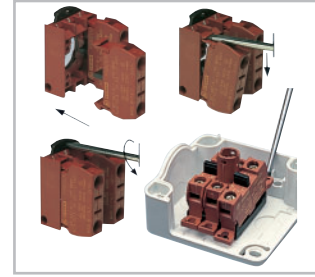

All the P9 rear panel devices are snap-on.

Mounting between panel and operator is accomplished by means of a patented snap-on flange which ensures a fast fitting.

For base mounting, the fitting is done directly on the adaptor inside the enclosures base.

Each single block can be mounted or removed individually.

In panel mounting, it is also possible to install or remove the snap-on mounting flange with the contact block group;

Blocks and/or flange can be disassembled by a standard screwdriver, to simplify operations.

### Safety and reliability



The P9 contact blocks are designed to ensure maximum reliability in every condition and to monitor control circuits at low energy levels (12V-5mA) minimum), thanks to advanced solution such as:

- four contact points
- high efficiency self-cleaning operation
- silver contacts properly shaped
- high contact pressure

### Mounting system

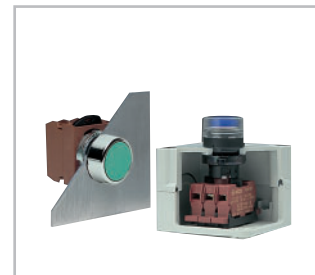

The P9 line offers a wide variety of operators, contact blocks and power supplies for panel mounting.

Furthermore a range of contact blocks and power supplies are available for base mounting.

The base mounting option is simple thanks to plastic enclosures fitted with a standard mounting adaptor, which allows a snap-on and secure fastening.

Control and signalling units Ø 22 mm

Intro

A

B

C

D

E

F

G

H

I

J/X



Panel mounting devices

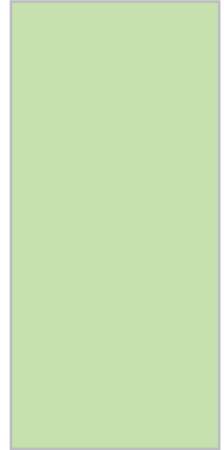

Control units

Standard push-b. F.11	Mushroom push-button F.11	Emergency push-button F.11	Key push-button F.11	Knob selector sw. F.12	Lever selector sw. F.13
Key selector sw. F.14	Selector push-b. F.17	Toggle switch F.17	Joystick F.19	Emergency lever F.18	Double push-b. F.9

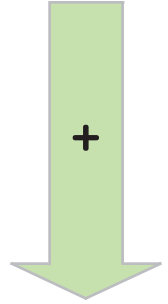

Contact blocks F.20				
------------------------	--	--	--	--



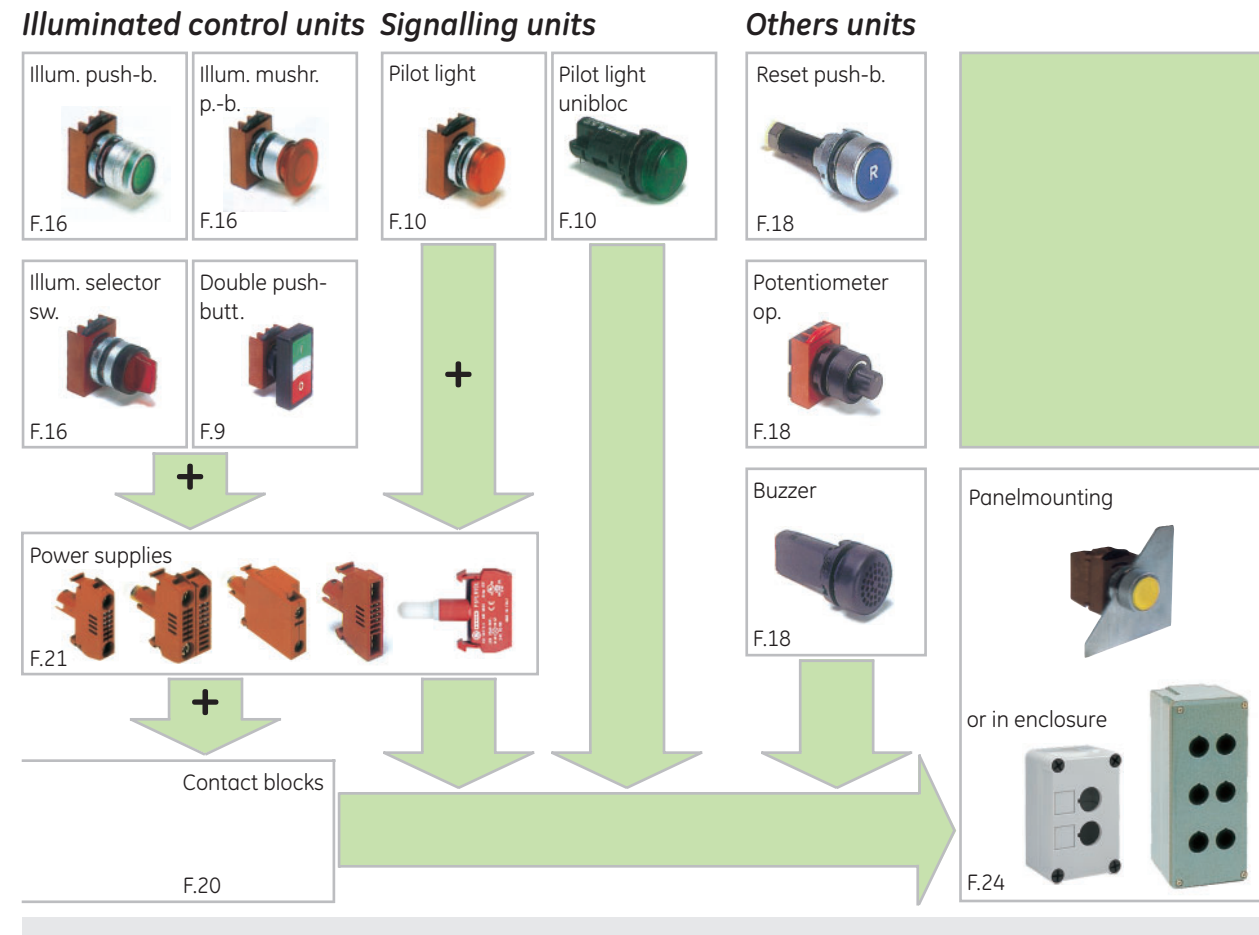

**Accessories**

General	Push-buttons	Mushroom push-buttons	Illuminated push-buttons	Illuminated mushroom push-buttons	Illuminated selector switches	Pilot lights
Nameplates F.51	Rubber caps F.28	Name plates F.32	Diffusers F.29	Collar F.30	Padlock F.30	Diffusers F.29
Plugs F.30	Padlock F.30	Collar Ø 40 F.30	Padlock F.30			
Flanges F.30	Push-on/push-off device F.30		Push-on/push-off device F.30			
Ring wrench F.30			Bulbs BA9S F.31			
Neutral plate F.32	Keys F.31			Bulb extractor F.30		

Range overview

- Intro
- A
- B
- C
- D
- E
- F**
- G
- H
- I
- J/X



## Technical data

### Compliance with standards

IEC 947.5.1 - VDE 0660 - NFC 63140  
IEC/EN 60947.5.1 - UTE - BSI - NEMA  
CENELEC EN 50007

### Approvals

cUL U.S. - RINA - CE - GOST R - Lloyd's Register of Shipping - Bureau Veritas - Germanischer Lloyd

### Climatic protections

The standard versions are suitable for use in the following climates:

Temperate climate	cat. 23/50 (DIN 50014)
Wet climate	cat. 23/83 (DIN 50015)
Hot wet climate	cat. 40/92 (DIN 50015)
Variable wet climate	FW24 (DIN 50016)

### Temperature ranges

Operation	-30 °C to + 70 °C
Storage	-40 °C to + 70 °C

### Protection degree of the operators

IP66 according to CENELEC EN 60529 when they are mounted into enclosures with the same or a higher degree of protection.

Suitable for using into enclosures type NEMA 1-3-3R-3S-4-4X-12-13 according to UL 508.

### Protection degree of the terminals

IP2x according to CENELEC EN 60529.

### Shock resistance (acc. to MIL 202 B method 202 A)

1/2 sinusoid 11 ms:

No damage or disassembling at 100 g for all devices, except for the illuminated operators with transformer 38 g.

### Vibration resistance (according to IEC 68-2-6)

16 g with frequency range from 40 to 500 Hz and maximum shifting 0.75 mm (peak-to-peak).

### Rated insulation voltage

690V according to EN 60947.1

### Impulse withstand voltage

4 kV according to EN 60947.1

### Insulation class

Groep C according VDE 0110

### Electrical shocks protection (acc. IEC 536)

Metal operators	Class I
Plastic operators	Class II (double insulation)

### Short-circuit protection

With fuses 16A gG according to IEC 269.1 and 269.3.

### Performances of the contacts

- Slow acting
- Self-cleaning sliding
- NC forced breaking
- Double movable bridge
- Four switching points
- Double break

### Electrical resistance of the contact

≤25 m Ω according to IEC 255, cat. 3

### Identification of the terminals

According CENELEC EN 50013

### Electrical performances

Rated thermal current I<sub>th</sub> = 10 A

#### Performances according IEC 947.5.1

Categorie AC 15									
Voltage	Ue (V)	24	48	60	110	220	380	500	600
Current	Ie (A)	10	10	10	6	3	2	1.5	1.2
Categorie DC 13									
Voltage	Ue (V)	24	48	60	110	220	300		
Current	Ie (A)	2.5	1.4	1	0.55	0.27	0.2		

#### Performances according to CSA and UL

AC Heavy Duty	(A600)
DC Standard Duty	(Q300)

### Operating range

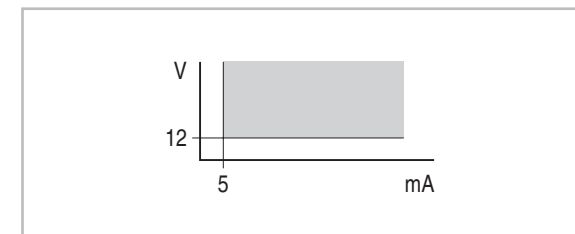

**Electrical endurance**

Alternative current 50/60 Hz cat. AC 15

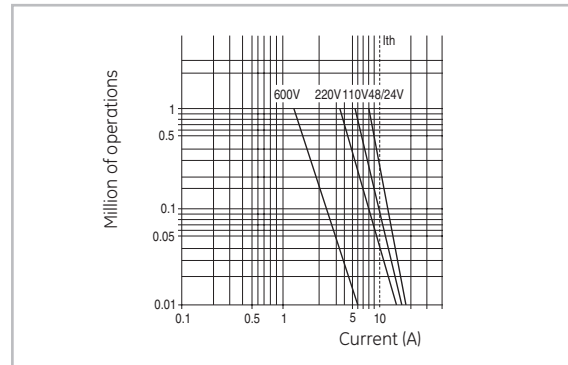

Direct current cat. DC 13

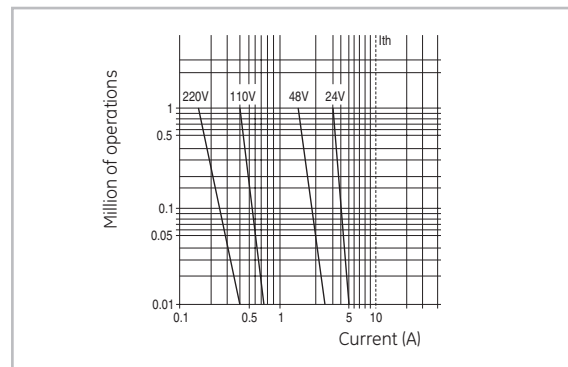

**Mechanical endurance**

Locking emergency	
Mushroom head push-buttons 3 positions	0.3 Mil./op.
Illuminated mushroom head push-buttons 3 pos.	
Joysticks	
Key push-buttons	
Toggle switches	0.5 Mil./op.
Illuminated selector switches	
Push-on push-off device	
Standard selector switches	
Key selector switches	
Illuminated push-buttons	1 Mil./op
Selector push-buttons	
Emergency lever	
Standard push-buttons	3 Mil./op.
Mushroom head push-buttons	

**Rear panel modularity**

The P9 series is composed with 10 mm or a multiple of 10 mm modular units, fitted side by side on a proper mounting flange. The standard operators are supplied with a three position flange with a capacity of 3 units of 10 mm or 1 of 10 mm and 1 of 20 mm or 1 of 30 mm. When the three position flange is not enough to satisfy the applications needs, the five position flange is required to add two more units of 10 mm mounted side by side. Using the five position flange take into account the bigger with (50 mm instead of 30 mm).

**Number of electrical contacts**

	Flange	
	standard 3 positions	optional 5 positions
Standard push-buttons		
Mushroom head push-buttons	max 6	max 8
Emergency lever		
Standard selectors	max 4	max 8
Key selector switches		
Joysticks		
Key push-buttons	max 4	-
Selector push-buttons		
Toggle switches		
Mushroom head with lock	max 4	-
Mushroom head push-buttons 3 pos.	max 2	
Illuminated push-buttons		
Illuminated mushroom head push-buttons	max 4	max 4
Illuminated selector switches		
Illuminated mush. push-buttons with lock	max 2	max 2
Illuminated mush. push-buttons 3 pos.		

**Mounting**

Fitted for panels 1 to 6 mm. thick with holes drilled according to CENELEC EN 50007 standards.

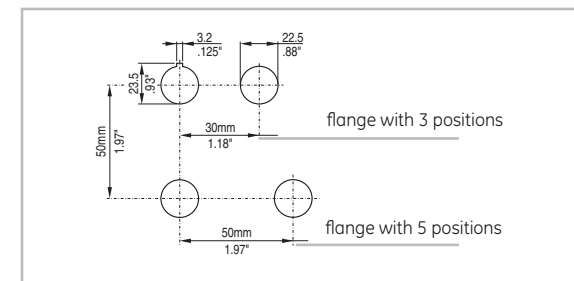

Technical data

Intro

A

B

C

D

E

F

G

H

I

J/X



Complete devices

	Description	Contact-block	Power supply	Cap colour	Cat. no.		Ref. no.	
					Metal	Plastic		
	Standard flush	1 NO		Black	<b>P9MPN53007</b>	153007	<b>P9XPN52007</b>	152007
				Green	<b>P9MPN53006</b>	153006	<b>P9XPN52002</b>	152002
	Standard raised	1 NC		Red	<b>P9MPN53061</b>	153061	<b>P9XPN52061</b>	152061
	Mushroom head momentary	1 NC		Red Ø 40	<b>P9MEM53111</b>	153111	<b>P9XEM52111</b>	152111
	Mush.with latch pull to release Twist to release	1 NC		Red Ø 40	<b>P9MET53121</b>	153121	<b>P9XET52121</b>	152121
	Twist to release VISION Key (3095) to release						<b>P9XER50775</b>	150775
							<b>P9XERW50776</b>	150776
	(1) Emergency stop as per EN 418 (2) Includes 2 keys						<b>P9XEC50777</b>	150777 <sup>2)</sup>
	2 fixed positions 	1 NO		Black	<b>P9MSM53293</b>	153293	<b>P9XSM52293</b>	152293
	3 fixed positions 	2 NO		Black	<b>P9MSM53391</b>	153391	<b>P9XSM52391</b>	152321
	2 fixed positions	1 NO		Key 3095	<b>P9MSC53435</b>	153435	<b>P9XSC52435</b>	152435
	2 fixed positions (includes plate I-0)						<b>P9XSC52434</b>	152434
	3 fixed positions 3 fixed positions (includes plate I-0-II)	2 NO		Key 3095	<b>P9MSC53497</b>	153497	<b>P9XSC52497</b>	152497
							<b>P9XSC52496</b>	152496

The catalogue numbers in **bold** are available from stock.

- Intro
- A
- B
- C
- D
- E
- F
- G
- H
- I
- J/X



Complete devices

	Description	Contact-block	Power supply	Cap colour	Cat. no.		Ref. no.	
					Metal	Plastic		
<b>Illuminated push-buttons</b> (Head + Standard full voltage power supply+ contact blocks)	Momentary flush (bulb not included)	1NO		Green	<b>P9MPL53502</b>	153502	<b>P9XPL52502</b>	152502
		1 NC		Red	<b>P9MPL53511</b>	153511	<b>P9XPL52511</b>	152511
		1NO + 1NC		Green	<b>P9MPL53514</b>	153514	<b>P9XPL52514</b>	152514
				Red	<b>P9MPL53515</b>	153515	<b>P9XPL52515</b>	152515
		White	<b>P9MPL53513</b>	153513	<b>P9XPL52513</b>	152513		
<b>Pilot lights</b>	Standard diffused lens- Full voltage Power supply		Green	<b>P9MLD53610</b>	153610	<b>P9XLD52610</b>	152610	
			Red	<b>P9MLD53611</b>	153611	<b>P9XLD52611</b>	152611	
	Standard diffused lens- Integrated LED 24VAC/DC		Green	<b>P9MLD53620</b>	153623	<b>P9XLD52620</b>	152620	
			Red	<b>P9MLD53621</b>	153621	<b>P9XLD52621</b>	152621	
<b>Double functions push-buttons</b> (Head + contact block & power supply when indicated)	Flush both caps	1 NO + 1NC		Green-red			<b>P9DPL54700</b>	154700
	Flush both caps - Full voltage power supply	1 NO + 1NC		Green-red			<b>P9DPL54720</b>	154720
	Flush both caps with ISO I/O Full voltage power supply	1 NO + 1NC		Green-red			<b>P9DPL54701</b>	154701
	Flush both caps with ISO I/O	1 NO + 1NC		Green-red			<b>P9DPL54721</b>	154721

The catalogue numbers in **bold** are available from stock.

Panel mounting

Intro

A

B

C

D

E

F

G

H

I

J/X



Pilot lights

Description	Cat. no.	Ref. no.	Cat. no.	Ref. no.	Cat. no.	Ref. no.
		<i>see bottom</i>		<i>see bottom</i>		<i>see bottom</i>
	Metal		Plastic		Plastic	
<b>Standard</b>						
Diffused lens (for filament bulb)	<b>P9ML●D</b>	<i>see bottom</i>	<b>P9XL●D</b>	<i>see bottom</i>	<b>P9SL●D</b>	<i>see bottom</i>
Refracted lens (for neon bulb)	<b>P9ML●R</b>	<i>see bottom</i>				
Glass lens	<b>P9ML●V</b>	<i>see bottom</i>				
<b>Unibloc (complete pilot light)</b>						
Full voltage AC/DC BA9S max 382 V - 2 W not included						
Diffused lens			P9XU●DD0	<i>see bottom</i>		
Refracted lens						
With resistor 220 V BA9S 110 V - 2 W included						
Diffused lens			P9XU●DRN	<i>see bottom</i>		
Refracted lens						

The catalogue numbers in **bold** are available from stock.

Colours		red	green	yellow	orange	blue	white	clear
Lens	●	<b>R</b>	<b>V</b>	<b>G</b>	<b>A</b>	<b>L</b>	<b>B</b>	<b>I</b>

Double function push-buttons <sup>(1)</sup>

	Colours (2)	Cat. no.	Ref. no.	Cat. no.	Ref. no.
		Plastic caps without symbols		Plastic caps with symbols	
<b>IP40 protection (acc. to IEC 529)</b>					
With white lens assembled for indicator light. Black insert for not illuminated function included in the packaging.					
	A - Black B - Red	P9DPLNRG00	186880	P9DPLNRG01	186890
	A - Green B - Red	<b>P9DPLVRG00</b>	186881	<b>P9DPLVRG01</b>	186891
	A - Black B - Red	P9DPLNRS00	186882	P9DPLNRS01	186892
	A - Green B - Red	P9DPLVRS00	186883	P9DPLVRS01	186893
<b>Clear cap (silicon rubber)</b>					
IP66 protection (acc. to IEC 529)					
	A - flush B - flush	080CPDT	173208	080CPDT	173208
	A - flush B - raised	P9ADCST	187796	P9ADCST	187796

The catalogue numbers in **bold** are available from stock.

(1) With white lens assembled.  
Black insert for not illuminated function included in the packaging.  
(2) Integral caps, colours not replacable.





Push-buttons

Standard / Momentary		Description	Cat. no.	Ref. no. see bottom	Cat. no.	Ref. no. see bottom	Cat. no.	Ref. no. see bottom
			Metal		Plastic		Plastic	
		With flush cap	P9MPN●G		P9XPN●G		P9SPN●G	
		With raised cap	P9MPN●S		P9XPN●S		P9SPN●S	
		Recessed	P9MPN●E					
Mushroom head / Momentary		Mushroom head Ø 28 mm	P9MEM3●N		P9XEM3●N*			
		Mushroom head Ø 40 mm	P9MEM4●N		P9XEM4●N*			
		Mushroom head Ø 60 mm	P9MEM6●N					
		Mushroom head Ø 30 mm					P9SEM3RN	186031
					* Color N or R			
Mushroom head with latch								
Standard	Push-pull to release	Mushroom head Ø40 mm	P9MET4●N1		P9XET4●N1		P9SET4R	186061
	Push-twist to release	Red mushroom head Ø28 mm	P9MER3RN	184070	P9XER3RN	185070		
		Red mushroom head Ø40 mm	P9MER4RN	184071	P9XER4RN	185071		
	Push-key to release	Red mushroom head Ø40 mm	P9MEC4RN▲		P9XEC4RN▲			
Emergency with latch								
Positive break in accordance with EN 418	Push-twist to release	Red mushroom head Ø40 mm			P9XER4RAN	185077	P9SER4RA	186072
	Push-twist to release	Red mushroom head Ø40 mm with status indication			P9XER4RAW	185078		
		Push-key to release	Red mushroom head Ø40 mm with key code 3095			P9XEC4RA95N	185079	P9SEC4RA95
Mushroom head / 3 positions								
		Ø40 mm 1-0 fixed, 2 transient	P9MET4●N2					
		Ø40 mm 0 fixed, 1-2 transient	P9MET4●N3					
With keylock (1)								
	Key withdrawable in position I & II	normal	P9MPCN1K▲					
		depressed	P9MPCN2K▲					
		normal & depressed	P9MPCN3K▲					
	Key withdrawable position III	normal	P9MPCN1E▲					
		depressed	P9MPCN2E▲					
		normal & depressed	P9MPCN3E▲					

(1) Keys on F.14

The catalogue numbers in bold are available from stock.

Colours	black	red	green	yellow	brown	blue	white	grey	without cap
Caps	● N	● R	● V	● G	● M	● L	● B	● H	● 0
Mushroom heads	● N	● R	● V	● G	● -	● L	● -	● -	● -

**Remark:** To complete the catalogue number, substitute the symbol ● by a letter for the choice of the colour and the symbol ▲ by a number for the type of key.

For reference numbers, see chapter X, pg. X.8

Panel mounting

Intro

A

B

C

D

E

F

G











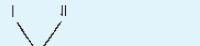
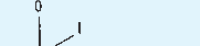
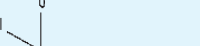
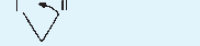

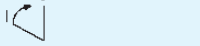



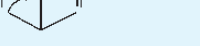

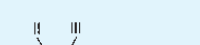

H

I

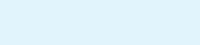
J/X

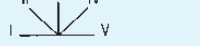
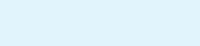
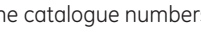
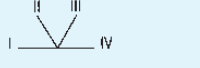

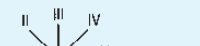
Selector switches with knob

2 positions		Function (1)	Cat. no.	Ref. no.	Cat. no.	Ref. no.	Cat. no.	Ref. no.
				see bottom		see bottom		see bottom
				Metal		Plastic		Plastic
	Fixed	 D	<b>P9MSMD0●</b>		<b>P9XSMD0N</b>	185110	<b>P9SSMD0N</b>	186110
		 I	<b>P9MSMI0●</b>		<b>P9XSMI0N</b>	185120	<b>P9SSMI0N</b>	186120
		 H	<b>P9MSMH0●</b>					
	With spring return	 D	<b>P9MSMD5●</b>		<b>P9XSMD5N</b>	185150	<b>P9SSMD5N</b>	186140
		 I	<b>P9MSMI5●</b>				<b>P9SSMI5N</b>	186150
		 H	<b>P9MSMH1●</b>					
3 positions								
	Fixed	 E	<b>P9MSME0●</b>				<b>P9SSME0N</b>	186170
		 L	<b>P9MSML0●</b>					
		 U	<b>P9MSMU0●</b>		<b>P9XSMU0N</b>	185190	<b>P9SSMU0N</b>	186190
		 Z, B	<b>P9MSMZ0●</b>		<b>P9XSMZ0N</b>	185200	<b>P9SSMZ0N</b>	186200
	With spring return	 E	<b>P9MSME1●</b>				<b>P9SSME1N</b>	186210
		 L	<b>P9MSML1●</b>					
		 U	<b>P9MSMU1●</b>		<b>P9XSMU1N</b>	185240	<b>P9SSMU1N</b>	186230
		 Z, B	<b>P9MSMZ1●</b>		<b>P9XSMZ1N</b>	185240	<b>P9SSMZ1N</b>	186240
		 E	<b>P9MSME5●</b>					
		 L	<b>P9MSML5●</b>					
		 U	<b>P9MSMU5●</b>		<b>P9XSMU5N</b>	185280	<b>P9SSMU5N</b>	186280
		 Z, B	<b>P9MSMZ5●</b>		<b>P9XSMZ5N</b>	185280	<b>P9SSMZ5N</b>	186280
	 E	<b>P9MSME3●</b>						
	 L	<b>P9MSML3●</b>						
	 U	<b>P9MSMU3●</b>		<b>P9XSMU3N</b>	185320	<b>P9SSMU3N</b>	186320	
	 Z, B	<b>P9MSMZ3●</b>		<b>P9XSMZ3N</b>	185320	<b>P9SSMZ3N</b>	186320	
4 positions								
Fixed	 X	<b>P9MSMX0●</b>		<b>P9XSMX0N</b>	185330	<b>P9SSMX0N</b>	186330	
	 X	<b>P9MSMX5●</b>						
5 positions								
Fixed	 X	<b>P9MSMY0●</b>						
	 W	<b>P9MSMW0●</b>						

(1) Electrical diagrams, see F.22

The catalogue numbers in **bold** are available from stock.

Colours round shape	black	red	green	yellow	blue	
Knobs	●	N	R	V	G	L

For reference numbers, see chapter X, pg. X.8



Selector switches with lever

2 positions		Function (1)	Cat. no.	Ref. no. see bottom	Cat. no.	Ref. no. see bottom
Fixed		D	<b>P9MSVD0</b>		<b>P9XSVD0N</b>	185370
		I	P9MSV10		P9XaSV10N	185371
		H	P9MSVH0			
With spring return		D	<b>P9MSVD5</b>		<b>P9XSVD5N</b>	185373
		I	P9MSV15			
		H	P9MSVH1			
<b>3 positions</b>						
Fixed		E	P9MSVE0			
		L	P9MSVL0			
		U	P9MSVU0			
		Z, B	<b>P9MSVZ0</b>		<b>P9XSZ0N</b>	185379
With spring return		E	P9MSVE1			
		L	P9MSVL1			
		U	P9MSVU1			
		Z, B	P9MSVZ1			
		E	P9MSVE5			
		L	P9MSVL5			
		U	P9MSVU5			
		Z, B	P9MSVZ5			
		E	P9MSVE3			
		L	P9MSVL3			
		U	P9MSVU3			
		Z, B	<b>P9MSVZ3</b>		<b>P9XSZ3N</b>	185391
<b>4 positions</b>						
Fixed		X	P9MSVX0		P9XS VX0N	185392
With spring return		X	P9MSVX5			
<b>5 positions</b>						
Fixed		X	P9MSVY0			
		W	P9MSVW0			

(1) Electrical diagrams, see F.22

The catalogue numbers in **bold** are available from stock.

Colours		black	red	green	yellow	blue
Levers	•	N	R	V	G	L

For reference numbers, see chapter X, pg. X.8

Panel mounting

Intro

A

B

C

D

E

F

G

H

I

J/X



Selector switches with key

2 positions		Function (1)	Key removal	Cat. no.	Ref. no.	Cat. no.	Ref. no.	Cat. no.	Ref. no.
Fixed				Metal		Plastic		Plastic (1)	
With spring return	D	I II	I	<b>P9MSCD0A</b>		<b>P9XSCD0A95</b>	185400	<b>P9SSCD0A95</b>	186400
			II	<b>P9MSCD0E</b>		<b>P9XSCD0E95</b>	185401		
			I-II	<b>P9MSCD0K</b>		<b>P9XSCD0K95</b>	185402		
	I	0	I	<b>P9MSCI0C</b>					
			I	<b>P9MSCI0E</b>					
			0-I	<b>P9MSCI0N</b>					
	H	I 0	I	<b>P9MSCH0A</b>					
			0	<b>P9MSCH0C</b>					
			I-0	<b>P9MSCH0H</b>					
	D	I	I	<b>P9MSCD5A</b>		<b>P9XSCD5A95</b>	185409	<b>P9SSCD5A95</b>	186409
			I	<b>P9MSCI5C</b>		<b>P9XSCI5C95</b>	185410	<b>P9SSCI5C95</b>	186410
			H	<b>P9MSCH1C</b>					

3 positions		Function (1)	Key removal	Cat. no.	Ref. no.	Cat. no.	Ref. no.	Cat. no.	Ref. no.		
Fixed				Metal		Plastic		Plastic (1)			
Fixed	E	I 0 II	I	<b>P9MSCE0A</b>							
			0	<b>P9MSCE0C</b>							
			II	<b>P9MSCE0E</b>							
			I-0	<b>P9MSCE0H</b>							
			I-II	<b>P9MSCE0K</b>							
			0-II	<b>P9MSCE0N</b>							
			I-0-II	<b>P9MSCE0T</b>							
			L	I 0 II	I	<b>P9MSCL0A</b>					
					0	<b>P9MSCL0C</b>					
	II	<b>P9MSCL0E</b>									
	I-0	<b>P9MSCL0H</b>									
	I-II	<b>P9MSCL0K</b>									
	0-II	<b>P9MSCL0N</b>									
	I-0-II	<b>P9MSCL0T</b>									
	U	I 0 II			I	<b>P9MSCU0A</b>					
					0	<b>P9MSCU0C</b>					
			II	<b>P9MSCU0E</b>							
			I-0	<b>P9MSCU0H</b>							
I-II			<b>P9MSCU0K</b>								
0-II			<b>P9MSCU0N</b>								
I-0-II	<b>P9MSCU0T</b>		<b>P9XSCU0T95</b>	185432							
Z, B	I 0 II	I	<b>P9MSCZ0A</b>		<b>P9XSCZ0A95</b>	185433					
		0	<b>P9MSCZ0C</b>		<b>P9XSCZ0C95</b>	185434					
		II	<b>P9MSCZ0E</b>		<b>P9XSCZ0E95</b>	185435					
		I-0	<b>P9MSCZ0H</b>								
		I-II	<b>P9MSCZ0K</b>								
		0-II	<b>P9MSCZ0N</b>								
		I-0-II	<b>P9MSCZ0T</b>		<b>P9XSCZ0T95</b>	185439	<b>P9SSCZ0T95</b>	186439			

(1) Electrical diagrams, see F.22

The catalogue numbers **in bold** are available from stock.

Keys for round metal shape

Standard version number	▲	95								
Standard version with specific number	▲	01	02	03	04	05	10	16	19	55 (Ronis)
FIAT version number	▲	33	34	37	38	40				
Colour		yellow	black	red	blue	orange				

(1) Key for square shape and round plastic shape, only standard version 95

For reference numbers, see chapter X, pg. X.8



**Selector switches with key**

3 positions		Function (1)	Key removal	Cat. no.	Ref. no. see bottom		Cat. no.	Ref. no. see bottom		
With spring return	Diagram				Metal	Plastic		Plastic (1)		
				E	0	<b>P9MSC1C▲</b>				
II	<b>P9MSC1E▲</b>									
0-II	<b>P9MSC1N▲</b>									
L	0			<b>P9MSCL1C▲</b>						
	II			<b>P9MSCL1E▲</b>						
	0-II			<b>P9MSCL1N▲</b>						
U	0		<b>P9MSCU1C▲</b>							
	II		<b>P9MSCU1E▲</b>							
	0-II		<b>P9MSCU1N▲</b>							
Z, B	0		<b>P9MSCZ1C▲</b>							
	II		<b>P9MSCZ1E▲</b>							
	0-II		<b>P9MSCZ1N▲</b>							
	E		I	<b>P9MSCE5A▲</b>						
			0	<b>P9MSCE5C▲</b>						
			I-0	<b>P9MSCE5H▲</b>						
	L		I	<b>P9MSCL5A▲</b>						
			0	<b>P9MSCL5C▲</b>						
			I-0	<b>P9MSCL5H▲</b>						
	U		I	<b>P9MSCU5A▲</b>						
			0	<b>P9MSCU5C▲</b>						
			I-0	<b>P9MSCU5H▲</b>						
Z, B	I		<b>P9MSCZ5A▲</b>	<b>P9XSCZ5A95</b>	185461	<b>P9SSCZ5A95</b>	186461			
	0		<b>P9MSCZ5C▲</b>	<b>P9XSCZ5C95</b>	185462					
	I-0		<b>P9MSCZ5H▲</b>	<b>P9XSCZ5H95</b>	185463					
	E	0	<b>P9MSC3C▲</b>							
	L	0	<b>P9MSCL3C▲</b>							
	U	0	<b>P9MSCU3C▲</b>							
	Z, B	0	<b>P9MSCZ3C▲</b>	<b>P9XSCZ3C95</b>	185467	<b>P9SSCZ3C95</b>	186467			
4 positions		Fixed		X	I	<b>P9MSCX0A▲</b>				
	II				<b>P9MSCX0B▲</b>					
	III	<b>P9MSCX0D▲</b>								
	IV	<b>P9MSCX0E▲</b>								
	I-II	<b>P9MSCX0F▲</b>								
	I-III	<b>P9MSCX0J▲</b>								
	I-IV	<b>P9MSCX0K▲</b>								
	II-III	<b>P9MSCX0L▲</b>								
	II-IV	<b>P9MSCX0M▲</b>								
	III-IV	<b>P9MSCX0P▲</b>								
	I-II-III	<b>P9MSCX0R▲</b>								
	I-II-IV	<b>P9MSCX0S▲</b>								
	I-III-IV	<b>P9MSCX0U▲</b>								
	II-III-IV	<b>P9MSCX0V▲</b>								
	I-II-III-IV	<b>P9MSCX0Z▲</b>								
	With spring return		X	I	<b>P9MSCX5A▲</b>					
				II	<b>P9MSCX5B▲</b>					
				III	<b>P9MSCX5D▲</b>					
				I-II	<b>P9MSCX5F▲</b>					
				I-III	<b>P9MSCX5J▲</b>					
				II-III	<b>P9MSCX5L▲</b>					
I-II-III	<b>P9MSCX5R▲</b>									

(1) Electrical diagrams, see F.22

The catalogue numbers in **bold** are available from stock.

**Keys for round metal shape**

Standard version number	▲	95								
Standard version with specific number	▲	01	02	03	04	05	10	16	19	55 (Ronis)
FIAT version number	▲	33	34	37	38	40				
Colour		yellow	black	red	blue	orange				

(1) Key for square shape and round plastic shape, only standard version 95

For reference numbers, see chapter X, pg. X.8

Panel mounting

Intro

A

B

C

D

E

F

G

H

I

J/X



**Illuminated push-buttons**

		Cat. no.	Ref. no.	Cat. no.	Ref. no.	Cat. no.	Ref. no.
		see bottom		see bottom		see bottom	
		Metal		Plastic		Plastic	
<b>Standard / Momentary</b>							
With diffused lens:							
Flush		<b>P9MPLGD</b>		<b>P9XPLGD</b>		<b>P9SPLGD</b>	
Raised		<b>P9MPLSD</b>		<b>P9XPLSD</b>		<b>P9SPLSD</b>	
Recessed		P9MPL <del>L</del> ED					
<b>Mushroom head / Momentary</b>							
Mushroom head Ø40 mm		<b>P9MEM4L</b>		<b>P9XEM4L*</b>			
Mushroom head 30 mm						P9SEM3RL	186551
<b>Mushroom head / With latch</b>							
Push-pull to release							
Mushroom head Ø40 mm		<b>P9MET4L1</b>		<b>P9XET4L1*</b>		P9SET4RL1	186561
				* Color R, V or G			
<b>Mushroom head / 3 positions</b>							
With mushroom Ø40 mm							
1-0 fixed, 2 transient		<b>P9MET4L2</b>		<b>P9XET4RL2</b>	185571		
0 transient, 1-2 fixed		<b>P9MET4L3</b>					

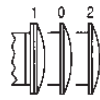

**Illuminated selector switches with knob**

	2 positions	Function (1)	Cat. no.		Ref. no.				
	Fixed		D	<b>P9MSLD0●</b>	<b>P9XSLD0●</b>	<b>P9SSLD0●</b>			
	Fixed		Z, B	<b>P9MSLZ0●</b>	<b>P9XSLZ0●</b>	<b>P9SSLZ0●</b>			
				With spring return		Z, B	<b>P9MSLZ1●</b>		
							<b>P9MSLZ5●</b>		
	<b>P9MSLZ3●</b>								

**Illuminated selector switches with lever**

	2 positions	Function (1)	Cat. no.		Ref. no.				
	Fixed		D	<b>P9MSAD0●</b>					
	Fixed		Z, B	<b>P9MSAZ0●</b>					
				With spring return		Z, B	<b>P9MSAZ1●</b>		
							<b>P9MSAZ5●</b>		
					<b>P9MSAZ3●</b>				

(1) Electrical diagrams, see F.22







The catalogue numbers in **bold** are available from stock.

Colours	red	green	yellow	orange	blue	white	clear
Lens	● <b>R</b>	● <b>V</b>	● <b>G</b>	● <b>A</b>	● <b>L</b>	● <b>B</b>	● <b>I</b>
Mushroomheads	● <b>R</b>	● <b>V</b>	● <b>G</b>	● <b>A</b>	● <b>L</b>	● <b>B</b>	● <b>I</b>
Knob/lever	● <b>R</b>	● <b>V</b>	● <b>G</b>	● <b>A</b>	● <b>L</b>	● <b>B</b>	● <b>I</b>







For reference numbers, see chapter X, pg. X.8



**Selector push-buttons (black coloured)**



	Function (1)	Cat. no.	Ref. no.	Metal		Plastic	
							
<b>2 positions</b>							
	Fixed		201	P9MPS21G	184690		
			231	<b>P9MPS22G</b>	184691		
			235	P9MPS23G	184692		
<b>3 positions</b>							
	Fixed		301	P9MPS34G	184693		
			323	P9MPS35G	184694		

**Toggle switches (black coloured)**

	Function (1)	Cat. no.	Ref. no.	Metal		Plastic			
<b>2 positions</b>									
	Fixed position		D	<b>P9MCD</b>	184695	<b>P9XCD</b>	185695	<b>P9SCD</b>	186695
<b>3 positions</b>									
	Fixed position		B	P9MCB	184696				
	Transient to zero from one position		B	P9MCC	184697				

The catalogue numbers in **bold** are available from stock.

**Rubber protective caps (IP66)**

Description	Cat. no.	Ref. no. see bottom	Plastic	
			Plastic	Plastic
				
Standard flush push-buttons	coloured (nitrilic rubber)	080CP●		P9ASCG●
	clear (silicon rubber)	080CPT	170198	P9ASCGT 170790
Raised push buttons	clear (silicon rubber)	P9ARCST	187490	P9ASCST 187791

Panel mounting

Intro

A

B

C

D

E

**F**

G

H

I

J/X



**Emergency lever**

	Cat. no.	Ref. no.	Cat. no.	Ref. no.	Cat. no.	Ref. no.
	Metal		Plastic		Plastic	
						
Red lever	P9MWR	184770				

**Reset push-button**

						
White symbol on blue background	P9MRG	184771	P9XRG	185771		

**Potentiometer operator (potentiometer not included)**

						
Black knob	P9MZ	184772	P9XZ	185772	P9SZ	186772

**Buzzer**

						
Black coloured Bitonal sound Full voltage AC/DC Frequency: 2kHz Sound intensity: 80dB at 1 m Consumption: 3 to 9 mA						
24 V			P9XBD	185773	P9SBD	186773
110-240 V			P9XBM	185774	P9SBM	186774







The catalogue numbers in **bold** are available from stock.

For reference numbers, see chapter X, pg. X.8





**Joysticks (black coloured)**

		Cat. no.	Ref. no.	Cat. no.	Ref. no.	Cat. no.	Ref. no.	
		Metal		Plastic		Plastic		
<b>2 positions + central zero position <sup>(1)</sup></b>								
 <p><b>Without interlock</b></p>		fixed positions	P9MMN2F	184700	P9XMN2F	185700		
		transient positions	<b>P9MMN2T</b>	184701	<b>P9XMN2T</b>	185701		
		1 transient - 3 fixed positions	P9MMN2A	184702				
		1 fixed - 3 transient positions	P9MMN2B	184703				
 <p><b>With interlock</b></p>		fixed positions	P9MMB2F	184710	P9XMB2F	185710		
		transient positions	<b>P9MMB2T</b>	184711	<b>P9XMB2T</b>	185711		
		1 transient - 3 fixed positions	P9MMB2A	184712	P9XMB2A	185712		
		1 fixed - 1 transient positions	P9MMB2B	184713	P9XMB2B	185713		
<b>4 positions + central zero position <sup>(1)</sup></b>								
 <p><b>Without interlock</b></p>		fixed positions	P9MMN4F	184720	P9XMN4F	185720		
		transient positions	<b>P9MMN4T</b>	184721	<b>P9XMN4T</b>	185721		
 <p><b>With interlock</b></p>		fixed positions	P9MMB4F	184740	P9XMB4F	185740		
		transient positions	P9MMB4T	184741	P9XMB4T	185741		

**Spare boots for joysticks**

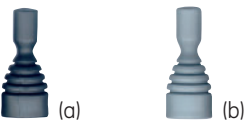
	Standard rubber boot for joystick	(a)	P9ARSCMN	188043		
	Standard rubber boot for joystick with interlock	(a)	P9ARSCMB	188044		
	Silicone boot for joystick	(b)	P9ARSGMN	187495		
	Silicone boot for joystick with interlock	(b)	P9ARSGMB	187496		

(1) Electrical diagrams, see F.22

The catalogue numbers **in bold** are available from stock.

Panel mounting

Intro

A

B

C

D

E

**F**

G

H

I

J/X

For reference numbers, see chapter X, pg. X.8



Contact blocks

Logic Reed

A new range of LOGIC REED contact blocks with faston terminals for use with power lower than 12V - 5mA.



		Cat. no.	Ref. no.
Contact type	NC	<b>P9B01FH</b>	187014
	NO	<b>P9B10FH</b>	187015
Rated voltage	AC2 to 120V max. DC2 to 30V max.		
Rated current	AC/DC - 0.001 to 0.15A max.		
Rated power	AC - 8VA max. DC - 4.5W max.		
Minimum centerline distance	30x32 mm.		
Mounting on operators	through specific bayonet flange adaptor.	<b>P9ACFSM</b>	187846
Full voltage power supply		<b>P9PDHF</b>	187056

With screw



min. 1 of 22 AWG (0.32 mm<sup>2</sup>)  
max. 2 of 12 AWG (3.3 mm<sup>2</sup>)













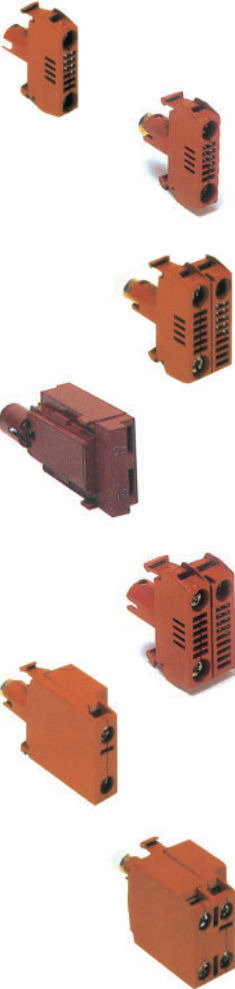

	Contact type	Cat. no.	Ref. no.
	NC+NO	<b>P9B11VN</b>	187000
	NC+NC	<b>P9B02VN</b>	187008
	NO+NO	<b>P9B20VN</b>	187009
	NC	<b>P9B01VN</b>	187001
	NO	<b>P9B10VN</b>	187002
	NC late opening	P9B01VR	187003
	NO early closing	P9B10VA	187004
	NC	<b>P9B01FN</b>	187012
	NO	<b>P9B10FN</b>	187013
	Terminal adapter printed circuit board adapter	<b>P9ACA6</b>	188804

The catalogue numbers in **bold** are available from stock.

- Intro
- A
- B
- C
- D
- E
- F**
- G
- H
- I
- J/X



Power supplies

With screw	Position on flange 2 3 1	Contact type	Cat. no.	Ref. no.	
 <p>min. 1 of 22 AWG (0.32 mm<sup>2</sup>) max. 2 of 12 AWG (3.3 mm<sup>2</sup>)</p> 		Full voltage ≙ IEC: BA9S max 380V-2W not included UL-CSA: BA9S max 250V-2W not included	<b>P9PDNV0</b>	187020	
		Logic Reed fullvoltage for low power	P9PDHF	187056	
		Long life 110/120V ≙ BA9S 130V-2W included	<b>P9PRLVJ</b>	187021	
		Resistor + Diode 220/240 V ~ BA9S 130V-2W included	<b>P9PRDVN</b>	187022	
		Resistor 110/120V ≙ BA9S 60V-1.2W included	<b>P9PRNVJ</b>	187023	
		220/240V ≙ BA9S 130V-2W included	<b>P9PRNVN</b>	187024	
		Resistor ENEL version BA9S 48V-2W included 110V ≙	<b>P9PREVJ</b>	187025	
		125/127V ≙	<b>P9PREVL</b>	187026	
		UL-CSA: BA9S max 250V-2W not included Test full voltage (1) ≙ IEC: BA9S max 380V-2W not included	<b>P9PDTV0</b>	187027	
		Test resistor (1) 220/240 V ≙ BA9S 130V-2W included	<b>P9PRTVN</b>	187028	
		Transformer 50/60 Hz BA9S 6V-1.5W included	<b>P9PTNV♦</b>	see bottom	
		Multifunction (2) full voltage 24V ≙ BA9S 24V-2W included	<b>P9PDMVD</b>	187040	
	Multifunction (2) full voltage 110V ≙ BA9S 130V-2W included	<b>P9PDMVJ</b>	187041		
	Multifunction (2) Transformer 50/60 Hz BA9S 6V-0.6W included	<b>P9PTMV♦</b>	see bottom		
<b>Faston</b>  <p>1 x (6.35 x 0.8 mm) 2 x (2.8 x 0.8 mm)</p> 		Full voltage IEC: BA9S max 380V-2W not included UL-CSA: BA9S max 250V-2W not included	<b>P9PDNF0</b>	187055	
		Standard light	24V AC/DC 120V AC 230V AC	<b>P9PLNVD♦</b> <b>P9PLNVJ♦</b> <b>P9PLNVN♦</b>	see bottom see bottom see bottom
<b>Integrated LED</b> 		Flashing light	24V AC/DC 120V AC 230V AC	<b>P9PLFVD♦</b> <b>P9PLFVJ♦</b> <b>P9PLFVN♦</b>	see bottom see bottom see bottom
		LED colour			
		The catalogue numbers <b>in bold</b> are available from stock.			

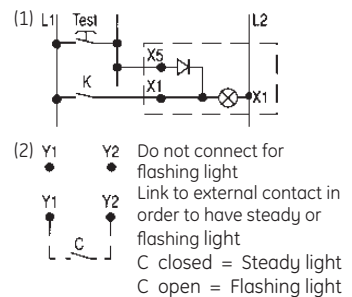

LED colour	orange	white	yellow	blue	red	green
	<b>A</b>	<b>B</b>	<b>G</b>	<b>L</b>	<b>R</b>	<b>V</b>
Voltage	110-120	220-250	380	415-440	480-500	
	<b>J</b>	<b>N</b>	<b>U</b>	<b>W</b>	<b>Y</b>	
	<b>J</b>	<b>N</b>	<b>U</b>	-	-	

For reference numbers, see chapter X, pg. X.8

Panel mounting

Intro

A

B

C

D

E

F

G

H

I

J/X



Diagrams

Selector switches

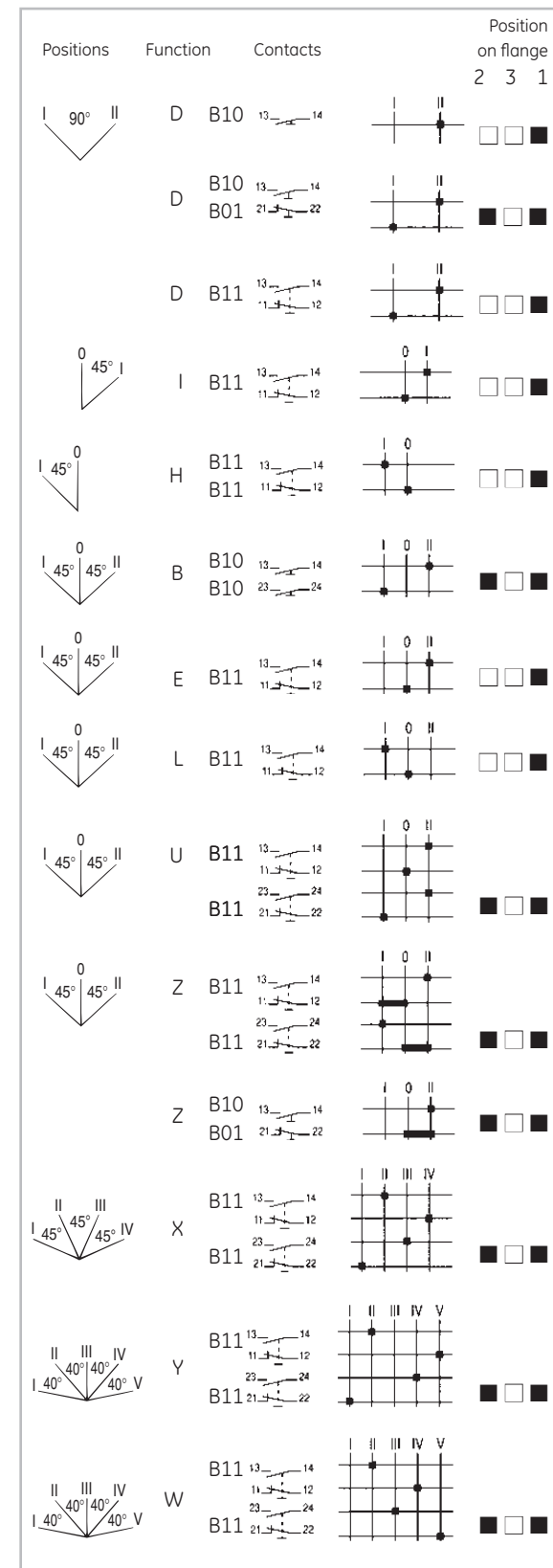

Selector push-buttons

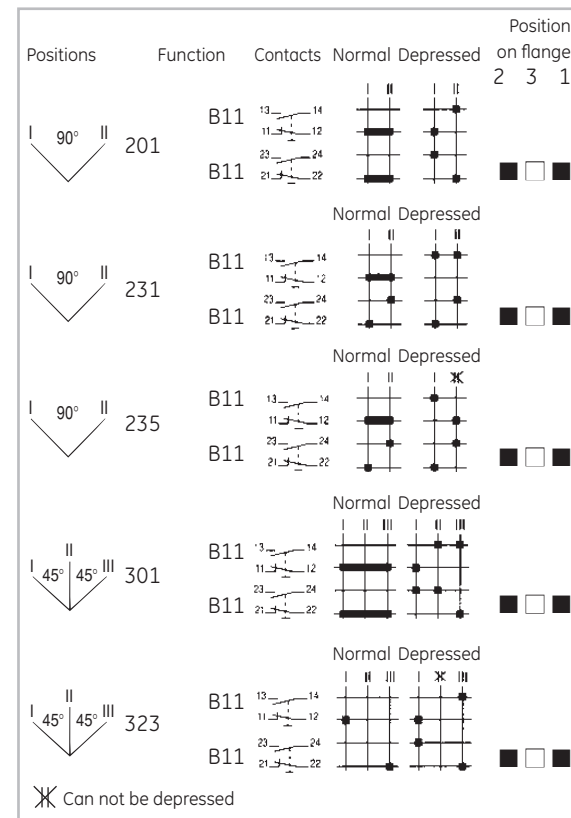

Joysticks

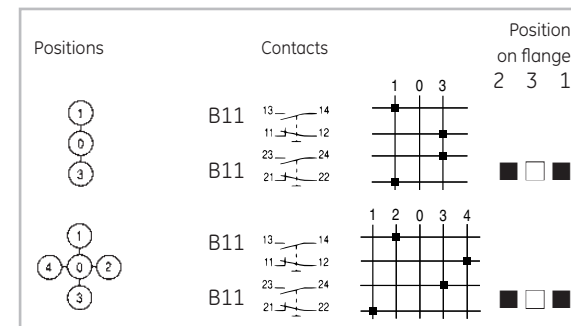



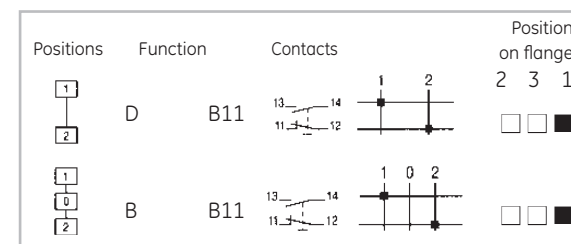

Toggle switches

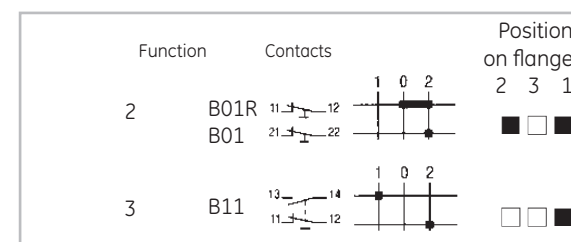





Mushroom head push-buttons 3 pos.

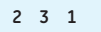

Base mounting - Contact blocks

With screw	Contact type	Cat. no.	Ref. no.
 <p>min. 1 of 22 AWG (0.32 mm<sup>2</sup>) max. 2 of 12 AWG (3.3 mm<sup>2</sup>)</p>	  NC	<b>P9B01BN</b>	187017
	  NO	<b>P9B10BN</b>	187018

Base mounting - Power supplies

With screw	Position on flange	Bulb power supply	Cat. no.	Ref. no.
 <p>min. 1 of 22 AWG (0.32 mm<sup>2</sup>) max. 2 of 12 AWG (3.3 mm<sup>2</sup>)</p>	   X1 X2	Full voltage ≙ IEC: BA9S max 380V-2W not included UL-CSA: BA9S max 250V-2W not included	<b>P9PDNB0</b>	187070
	  x1 x2	Standard light 24V AC/DC 120V AC 230V AC	<b>P9PLNBD</b> • see bottom <b>P9PLNBJ</b> • see bottom <b>P9PLNBN</b> • see bottom	

The catalogue numbers **in bold** are available from stock.

LED colour	orange	white	yellow	blue	red	green
	A	B	G	L	R	V

For reference numbers, see chapter X, pg. X.8

Base mounting

Intro

A

B

C

D

E

F

G

H

I

J/X



**Empty box for DIN Rail application (Light grey coloured RAL 7035)**



	Cat. no.	Ref. no.
1	<b>P9EPEM</b>	189200
- Up to 3 base mounting contact blocks and power supplies - 1 hole P9EPEM 189200 - Can be used in modular cabinet - 36mm width - Double protection		

**Push-button stations in thermoplastic (Light grey coloured RAL 7035)**

*For panel and base mounting*

- IP66 according to IEC529, EN 60529
- Engineered thermoplastic covers, bases and screws
- Self extinguishing Class V0, according to UL 94
- Rust resistant (4X according to UL 508)
- Total insulation with all thermoplastic operators
- Contact blocks and power supplies for both base and front mounting

*Empty versions*

**Cover with holes  
Knockouts conduit entry**



Number of holes	Cat. no.	Ref. no.
1 (yellow cover)	<b>P9EPEG1</b>	189000
1	<b>P9EPE01</b>	189001
2	<b>P9EPE02</b>	189002
2 (yellow cover)	<b>P9EPEG2</b>	189006
3	<b>P9EPE03</b>	189003
4	<b>P9EPE04</b>	189004
6	<b>P9EPE06</b>	189005

For panel mounting

*Accessories*

**Write-on plates**



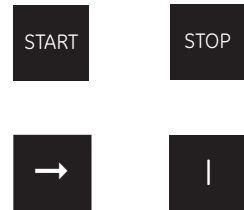

Bilaminated, self adhesive, 20 x 20 mm  
Black background  
engrivable for white texts



Description	Symbols	Cat. no.	Ref. no.
Without text		<b>P9AELN</b>	<b>189030</b>
Text in English (1) START		P9AELN202	189031
STOP		P9AELN201	189032
FORWARD		P9AELN214	189033
REVERSE		P9AELN215	189034
CLOSE		P9AELN205	189035
OPEN		P9AELN206	189036
UP		P9AELN204	189037
DOWN		P9AELN203	189038
LEFT		P9AELN222	189152
RIGHT		P9AELN224	189154
	→	P9AELN006	189041
	I	P9AELN028	189042
	0	P9AELN029	189043
	II	P9AELN035	189044
	III	P9AELN038	189045
	0-I	P9AELN039	189046
	I-0-II	P9AELN042	189047
<b>Earth terminal clamp</b>		<b>P9AEMT</b>	<b>189029</b>

The catalogue numbers in **bold** are available from stock.

**Push-button stations in thermoplastic (continued)**

Equipped versions		Operators	Colour	Diagram	Name-plate	Cat. no.	Ref. no.
 	One unit	Flush push-button	green	$\begin{matrix} 13 \\ \diagdown \\ 4 \end{matrix}$	I	<b>P9EPA01Y02</b>	189010
		Flush push-button	white	$\begin{matrix} 13 \\ \diagdown \\ 4 \end{matrix}$	I	<b>P9EPA01Y03</b>	189011
		Emergency push-button with latch according to EN418 (yellow cover)	red	$\begin{matrix} 1L \\ 2 \end{matrix}$	0	<b>P9EPAG1Y0N</b>	189007
		Emergency push-button with latch & status indicator according to EN418 (yellow cover)	red	$\begin{matrix} 1L \\ 2 \end{matrix}$	0	<b>P9EPAG1Y01W</b>	189008
		Emergency push-button with latch according to EN418 - key to release (yellow cover)	red	$\begin{matrix} 1L \\ 2 \end{matrix}$	0	<b>P9EPAG1Y06N</b>	189009
Equipped versions		Operators	Colour	Diagram	Name-plate	Cat. no.	Ref. no.
	Two units	Flush push-buttons	green	$\begin{matrix} 13 \\ \diagdown \\ 4 \end{matrix}$	I	<b>P9EPA02Y01</b>	189016
		Flush push-buttons	red	$\begin{matrix} 1L \\ 2 \end{matrix}$	0		
	Three units	Full voltage pilot light max 380V-2W not included	BA9S	$\begin{matrix} \text{⊗} \times 1 \\ \text{⊗} \times 2 \end{matrix}$	blank	<b>P9EPA03Y01</b>	189018
		Flush push-buttons	green	$\begin{matrix} 13 \\ \diagdown \\ 4 \end{matrix}$	I		
		Flush push-buttons	red	$\begin{matrix} 1L \\ 2 \end{matrix}$	0		
		Flush push-buttons	black	$\begin{matrix} 13 \\ \diagdown \\ 4 \end{matrix}$	↑	<b>P9EPA03Y05</b>	189022
		Flush push-buttons	red	$\begin{matrix} 1L \\ 2 \end{matrix}$	0		
Flush push-buttons	black	$\begin{matrix} 13 \\ \diagdown \\ 4 \end{matrix}$	↓				

**Equipped boxes**

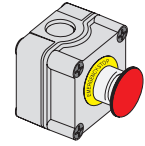
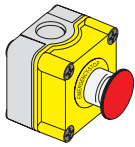
Equipped boxes		Composition	Individual operators	Cat. no.	Ref. no.	Pack
Specially enclosures to use for shaft lifts (other versions, please contact us)						
 	One operator	Thermoplastic box. 1 element	P9EPE01	<b>P9EPC01X00</b>	215432	1
		Emergency push button mushroom head Ø40, push-pull to release	P9XET4RN1			
		1NC contact block	P9B01VN			
		1NO contact block	P9B10VN			
		Nameplate with inscription "EMERGENCY-STOP"	080XTGR02			
		PG16 packing gland				
		Thermoplastic box. Yellow cover. 1 element	P9EPEG1	<b>P9EPC01X01</b>	215433	1
		Emergency push-button mushroom head Ø40, push-twist to release	P9XER4RN			
		1NC contact block	P9B01VN			
		Nameplate with inscription "EMERGENCY-STOP"	080XTGR02			

(1) Other languages on request

The catalogue numbers in **bold** are available from stock.

Push-button stations

Intro

A

B

C

D

E

F

G

H

I

J/X



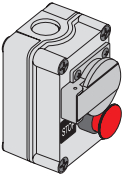
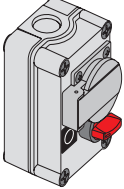
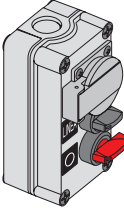
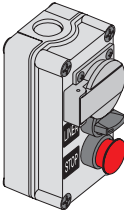
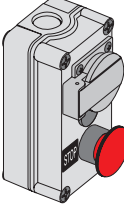
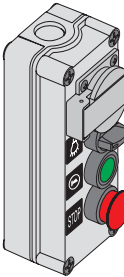

Equipped boxes (continued)

Specially enclosures to use for shaft lifts (other versions, please contact us)		Composition	Individual operators	Cat. no.	Ref. no.	Pack
	<b>Two operators</b>	Thermoplastic box, 2 elements	P9EPE02	<b>P9EPL02X01</b>	189136	1
		Emergency push-button mushroom head Ø28, push-twist to release	P9XER3RN			
1NC contact block	P9B01VN					
Nameplate with inscription "STOP"	P9AELN201					
16A Schuko socket-outlet with cover						
		Thermoplastic box, 2 elements	P9EPE02	<b>P9EPL02X02</b>	189137	1
		Selector switch, 2 positions, with red knob	P9XSMD0R			
1NC contact block	P9B01VN					
Nameplate with inscription "O-I"	P9AELN039					
16A Schuko socket-outlet with cover						
	<b>Three operators</b>	Thermoplastic box, 3 elements	P9EPE03	<b>P9EPL03X01</b>	189138	1
		Selector switch, 2 positions, with black knob	P9XSMD0N			
1NC contact block	P9B01VN					
1NO contact block	P9B10VN					
Nameplate with inscription "LINEA"	P9AELN523					
Selector switch, 2 positions, with red lever	P9XSVD0R					
1NO contact block	P9B10VN					
Nameplate with inscription "O-I"	P9AELN039					
16A Schuko socket-outlet with cover						
		Thermoplastic box, 3 elements	P9EPE03			
		Selector switch, 2 positions, with black knob	P9XSMD0N			
1NC contact block	P9B01VN					
1NO contact block	P9B10VN					
Nameplate with inscription "LINEA"	P9AELN523					
Emergency push-button mushroom head Ø28, push-twist to release	P9XER3RN					
1NC contact block	P9B01VN					
Nameplate with inscription "STOP"	P9AELN201					
16A Schuko socket-outlet with cover						
		Thermoplastic box, 3 elements	P9EPE03	<b>P9EPL03X03</b>	189140	1
		Emergency push-button mushroom head Ø40, push-twist to release	P9XER4RN			
1NC contact block	P9B01VN					
Nameplate with inscription "STOP"	P9AELN201					
Round plug	P9ARHPR					
16A Schuko socket-outlet with cover						
	<b>Four operators</b>	Thermoplastic box, 4 elements	P9EPE04	<b>P9EPL04X01</b>	189141	1
		Selector switch, 2 positions, with black knob	P9XSMD0N			
1NC contact block	P9B01VN					
1NO contact block	P9B10VN					
Nameplate with "Light" symbol	P9AELN100					
Standard/momentary push button with flush cap, green	P9XPNVG					
1NO contact block	P9B10VN					
Nameplate with "Bell" symbol	P9AELN099					
Emergency push-button mushroom head Ø28, push-twist to release	P9XER3RN					
1NC contact block	P9B01VN					
Nameplate with inscription "STOP"	P9AELN201					
16A Schuko socket-outlet with cover						

The catalogue numbers in **bold** are available from stock.



**Push-button stations in aluminium (Grey coloured RAL 7012)**

For panel mounting	Protection	Number of holes	Type	Cat. no.	Ref. no.
 <p>Cover with holes with conduit entry</p>	IP66 (according to IEC 529, EN 60529)	1	1	<b>080SP1</b>	170801
		1	1M (1)	<b>080SP1M</b>	170831
		2	2	<b>080SP2</b>	170802
		2	2M (1)	<b>080SP2M</b>	170832
		3	3	<b>080SP3</b>	170803
		4	4	<b>080SP4</b>	170804
		4	4M (1)	<b>080SP4M</b>	170834
		6	6	<b>080SP6</b>	170806
		8	8	<b>080SP8</b>	170807
		12	12	<b>080SP12</b>	170808
		18	18	<b>080SP18</b>	170809
		24	24	<b>080SP24</b>	170810
		35	35	<b>080SP35</b>	170811
		<p>Cover with holes without conduit entry</p>	IP66 (according to IEC 529, EN 60529)	1	1
1	1M (1)			080SP1MSFE	170839
2	2			080SP2SFE	170842
2	2M (1)			080SP2MSFE	170845
3	3			080SP3SFE	170848
4	4			080SP4SFE	170850
4	4M (1)			080SP4MSFE	170851
6	6			080SP6SFE	170852
8	8			080SP8SFE	170854
12	12			080SP12SFE	170857
18	18			080SP18SFE	170860
24	24			080SP24SFE	170862
35	35			080SP35SFE	170864
 <p>Cover without holes with conduit entry</p>	IP66 (according to IEC 529, EN 60529)			1	1
		1	1M (1)	080SP1MSFC	170838
		2	2	080SP2SFC	170841
		2	2M (1)	080SP2MSFC	170844
		3	3	080SP3SFC	170847
		4	4	080SP2SFC	170841
		4	4M (1)	080SP2MSFC	170844
		6	6	080SP3SFC	170847
		8	8	080SP8SFC	170853
		12	12	080SP12SFC	170856
		18	18	080SP18SFC	170859
		24	24	080SP18SFC	170859
		35	35	080SP35SFC	170863
		<p>Cover without holes without conduit entry</p>	IP66 (according to IEC 529, EN 60529)	1	1
1	1M (1)			080SP1MSF	170840
2	2			080SP2SF	170843
2	2M (1)			080SP2MSF	170846
3	3			080SP3SF	170849
4	4			080SP2SF	170843
4	4M (1)			080SP2MSF	170846
6	6			080SP3SF	170849
8	8			080SP8SF	170855
12	12			080SP12SF	170858
18	18			080SP18SF	170861
24	24			080SP18SF	170861
35	35			080SP35SF	170865

(1) With deep socle

**Accessories**

Description	Cat. no.	Ref. no.
Kit of two hinges for types 18, 24, 35 with holes	<b>080KCSP</b>	170883

Overall dimensions, see F.41

The catalogue numbers in **bold** are available from stock.

Push-button stations

Intro

A

B

C

D

E

**F**

G















H

I

J/X



Caps for standard push-buttons

	Colour	Cat. no.	Ref. no.	Cat. no.	Ref. no.	Cat. no.	Ref. no.	Cat. no.	Ref. no.
		Flush and recessed		Raised		Flush		Raised	
Neutral									
		<b>P9ARBG ●</b>	18710 ■	<b>P9ARBS ●</b>	18720 ■	<b>P9ASBG ●</b>	18750 ■	<b>P9ASBS ●</b>	18760 ■
With symbols <sup>(1)</sup>									
Stop 	Black	<b>P9ARBGN 029</b>	187150	<b>P9ARBSN 029</b>	187250	<b>P9ASBGN 029</b>	187550	<b>P9ASBSN 029</b>	187650
	Red	<b>P9ARBGR 029</b>	187110	<b>P9ARBSR 029</b>	187210	<b>P9ASBGR 029</b>	187510	<b>P9ASBSR 029</b>	187610
Start 	Black	<b>P9ARBGN 028</b>	187111	<b>P9ARBSN 028</b>	187211	<b>P9ASBGN 028</b>	187511	<b>P9ASBSN 028</b>	187611
	Green	<b>P9ARBGV 028</b>	187112	<b>P9ARBSV 028</b>	187212	<b>P9ASBGV 028</b>	187512	<b>P9ASBSV 028</b>	187612
	White	<b>P9ARBGB 028</b>	187151	<b>P9ARBSB 028</b>	187251	<b>P9ASBGB 028</b>	187551	<b>P9ASBSB 028</b>	187651
Continuous rectilinear motion 	Black	<b>P9ARBGN 006</b>	187117	<b>P9ARBSN 006</b>	187217	<b>P9ASBGN 006</b>	187517	<b>P9ASBSN 006</b>	187617
	Green	<b>P9ARBGV 006</b>	187118	<b>P9ARBSV 006</b>	187218	<b>P9ASBGV 006</b>	187518	<b>P9ASBSV 006</b>	187618
	White	<b>P9ARBGB 006</b>	187152	<b>P9ARBSB 006</b>	187252	<b>P9ASBGB 006</b>	187552	<b>P9ASBSB 006</b>	187652
Increase 	Black	P9ARBGN 017	187125						
Decrease 	Black	P9ARBGN 018	187127						
Reset 	Blue	P9ARBGL 037	187143			P9ASBGL 037	187543	P9ASBSL 037	187643
Stop/Reset 	Red	P9ARBGR 036	187144						
Test 	Black	P9ARBGN 030	187145	P9ARBSN 030	187245	P9ASBGN 030	187545	P9ASBSN 030	187645
	Green	P9ARBGV 030	187146	P9ARBSV 030	187246	P9ASBGV 030	187546	P9ASBSV 030	187646
Stop 	Red	<b>P9ARBGR 201</b>	187147	<b>P9ARBSR 201</b>	187247	<b>P9ASBGR 201</b>	187547	<b>P9ASBSR 201</b>	187647
Start 	Black	<b>P9ARBGN 202</b>	187148	<b>P9ARBSN 202</b>	187248	<b>P9ASBGN 202</b>	187548	<b>P9ASBSN 202</b>	187648
	Green	<b>P9ARBGV 202</b>	187149	<b>P9ARBSV 202</b>	187249	<b>P9ASBGV 202</b>	187549	<b>P9ASBSV 202</b>	187649
	White	<b>P9ARBGB 202</b>	188909	<b>P9ARBSB 202</b>	188978	<b>P9ASBGB 202</b>	189859	<b>P9ASBSB 202</b>	189928

















(1) Other symbols on request

The catalogue numbers in **bold** are available from stock.

Colours		black	red	green	yellow	brown	blue	white	grey
Caps	●	<b>N</b>	<b>R</b>	<b>V</b>	<b>G</b>	<b>M</b>	<b>L</b>	<b>B</b>	H



Diffusers/insert for illuminated units

		Cat. no.	Ref. no.	Cat. no.	Ref. no.	Cat. no.	Ref. no.
		For pilot lights		For illuminated push buttons		For pilot lights and illuminated push buttons	
<b>Neutral</b>							
		P9ARDLS	187300	P9ARDPL	187350	080QDF	173220
<b>With symbols<sup>(1)</sup></b>		on white background					
Stop		<b>P9ARDLS029</b>	187301	<b>P9ARDPL029</b>	187351	<b>080QDF029</b>	187701
Start		<b>P9ARDLS028</b>	187302	<b>P9ARDPL028</b>	187352	<b>080QDF028</b>	187702
Continuous rectilinear motion		<b>P9ARDLS006</b>	187305	<b>P9ARDPL006</b>	187355	<b>080QDF006</b>	187705
Increase		P9ARDLS017	187309	P9ARDPL017	187359	080QDF017	187709
Decrease		P9ARDLS018	187310	P9ARDPL018	187360	080QDF018	187710
Auto cycle		P9ARDLS026	187311	P9ARDPL026	187361	080QDF026	187711
Manual		P9ARDLS027	187312	P9ARDPL027	187362	080QDF027	185788
Locking		P9ARDLS031	187313	P9ARDPL031	187363	080QDF031	187713
Releasing		P9ARDLS032	187314	P9ARDPL032	187364	080QDF032	187714
Coolant		P9ARDLS001	187315	P9ARDPL001	187365	080QDF001	187715
Light		P9ARDLS002	187316	P9ARDPL002	187366	080QDF002	187716
Test		P9ARDLS030	187318	P9ARDPL030	187368	080QDF030	185789
Stop		<b>P9ARDLS201</b>	187319	<b>P9ARDPL201</b>	187369	<b>080QDF201</b>	187719
Start		<b>P9ARDLS202</b>	187320	<b>P9ARDPL202</b>	187370	<b>080QDF202</b>	187720

(1) Other symbols on request

The catalogue numbers in **bold** are available from stock.

Common accessories

Intro

A

B

C

D

E

F

G

H

I

J/X



Common accessories

Plugs	Description	Cat. no.	Ref. no.	Cat. no.	Ref. no.
		Plastic		Plastic	
	Round	<b>P9ARHPR</b>	187491		
	Square 30 x 30 mm			<b>P9ASHP3</b>	187792
	Rectangular 30 x 50 mm			<b>P9ASHP5</b>	187793
<b>Protections</b>					
	Collar for mushroom head push-buttons Ø40 mm.	P9ARRE4	187492		
	Protection cover padlockable for standard push-buttons, illuminated push-buttons, selector switches, illuminated selector switches with knob.	P9ACRCL	187840	P9ACRCL	187840
<b>Flanges</b>					
	With three positions Centre distances 30 x 50 mm	P9ACFS3	187841	P9ACFS3	187841
	With five positions Centre distances 50 x 50 mm	<b>P9ACFS5</b>	187842	<b>P9ACFS5</b>	187842
	With two positions For Logic Reed contact blocks	<b>P9ACFSM</b>	187846	<b>P9ACFSM</b>	187846
<b>Adapter screw plug-in terminal</b>					
	Only for Logic Reed contact blocks and power supplies	<b>P9ACAFV</b>	187847	<b>P9ACAFV</b>	187847
<b>Adapter</b>					
	Gives round control and signalling units a square appearance. Made in black thermoplastic. Can be used with nameplate for square operators P9ASTBS (see P.30). Excluded for mushroom flush buttons with positive break and types with 3 positions.	<b>P9ARSN1</b>	188805		
<b>Push-on/push off</b>					
	Device for standard push-buttons and illuminated push-buttons. To be added only to single pole contact blocks. The NO-contacts must be early closing types.	<b>P9ACDPP</b>	187843	<b>P9ACDPP</b>	187843
<b>Extended screw</b>					
	For reset push-buttons (setting min. 80, max. 170 mm)	P9ACVLR	187844	P9ACVLR	187844
<b>Central contact driving plug</b>					
	For standard momentary push-buttons and momentary mushroom head push-buttons.			P9ASHAC	187794
<b>Tools</b>					
	Locking ring wrench	<b>P9ACWAF</b>	187845	<b>P9ACWAF</b>	187845
	Bulb extractor	<b>080ESL</b>	170212	<b>080ESL</b>	170212
	Extractor for caps and lenses			<b>P9ASEBG</b>	187795

The catalogue numbers in **bold** are available from stock.

Spare keys



Description		Cat. no.	Ref. no.
		Plastic	
Standard version	Code		
	3095	<b>077C3095</b>	173095
	9901	077C9901	173901
	9902	077C9902	173902
	9903	077C9903	173903
	9904	077C9904	173904
	9905	077C9905	173905
	9910	077C9910	173910
	9916	077C9916	173916
	9919	077C9919	173919
	3353	077C3353	173353
	(Ronis) 455	077CR455	173455
FIAT version	Colour	Code	
	yellow	73033	077CF73033
	black	73034	077CF73034
	red	73037	077CF73037
	blue	73038	077CF73038
	orange	73040	077CF73040

Bulbs BA9s



Description		Cat. no.	Ref. no.
		Plastic	
Filament type	Vn	W	
	6	0.6	<b>BA9S606</b> 187850
	6	1.5	<b>BA9S615</b> 187851
	12	2.0	BA9S122 187852
	24	2.0	<b>BA9S242</b> 187853
	30	2.1	<b>BA9S30</b> 187854
	48	2.0	BA9S48 187855
	60	1.2	BA9S6012 187856
	130	2.0	<b>BA9S130</b> 187857
	220	2.0	BA9S220 187868
Neon type			
	110	0.11	BA9SN110 187860
	220	0.33	<b>BA9SN220</b> 187861
MultiLED	VN AC/DC ± 10%		
	6	BA9S6LED•	
	12	BA9S12LED•	
	24	BA9S24LED•	
	48	BA9S48LED•	
	60	BA9S60LED	187191
	110	BA9S110LED•	
	130	BA9S130LED	187190
	(AC) 230	BA9S230LED•	

Colours	red	green	yellow	blue	white
•	R	V	G	L	B

Insert holders

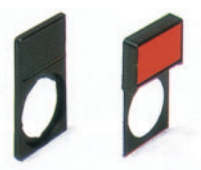

Description		Cat. no.	Ref. no.	Cat. no.	Ref. no.
		Plastic		Plastic	
Supplied with neutral insert engravable on both sides or transparent.					
Standard 30 x 50 mm	Background black/red, white text	<b>P9ARTBS</b>	188000	<b>P9ASTBS</b>	188010
	Background white, black text	<b>P9ARTWS</b>	188005	<b>P9ASTWS</b>	188011
	Transparent	<b>P9ARTTS</b>	188012	<b>P9ASTTS</b>	188014
Extended 45 x 50 mm	Background black/red, white text	<b>P9ARTBM</b>	188001		
	Background white, black text	<b>P9ARTWM</b>	188008		
	Transparent	<b>P9ARTTM</b>	188019		

The catalogue numbers in bold are available from stock.

For reference numbers, see chapter X, pg. X.8

Common accessories

Intro

A

B

C

D

E

F

G

H

I

J/X



**Rectangular inserts**

For insert holders 30 x 50 mm						
Neutral						
Description	Cat. no.	Ref. no.	Description	Cat. no.	Ref. no.	
black/red background	<b>P9ACPBS</b>	188015				
white background	<b>P9ACPWS</b>	188017				
transparent	<b>P9ACPTS</b>	188018				
English (1)			Aluminium English (1)			
black background	START	P9ACPBS202	188202	Without inscription	P9ARTAPN	116099
	STOP	P9ACPBS201	188201	O - I	P9ARTAPN039	116140
	REVERSE	P9ACPBS215	188215	I O II	P9ARTAPN042	116141
	CLOSE	P9ACPBS205	188205	ON	P9ARTAPN212	116147
	OPEN	P9ACPBS206	188206	RESET	P9ARTAPN291	116150
	UP	P9ACPBS204	188204	I II	P9ARTAPN040	116991
	DOWN	P9ACPBS203	188203	I	P9ARTAPN028	118846
	LEFT	P9ACPBS222	188222	STOP	P9ARTAPN201	116143
	RIGHT	P9ACPBS224	188224	START	P9ARTAPN202	116144
	FAST	P9ACPBS208	188208	OPEN	P9ARTAPN206	116145
	SLOW	P9ACPBS207	188207	OFF	P9ARTAPN213	116148
	OPEN-CLOSE	P9ACPBS234	188234			
	HAND-AUTO	P9ACPBS243	188243			
	STOP-START	P9ACPBS232	188232			
	FORWARD-REVERSE	P9ACPBS231	188231			
	OFF-ON	P9ACPBS233	188233			
	AUTO-OFF-HAND	P9ACPBS258	188258			
	FORWARD-0-REVERSE	P9ACPBS239	188239			
	O - I	<b>P9ACPBS039</b>	188030			
For insert holders 45 x 50 mm						
Neutral						
black/red background, white text	<b>P9ARPBM</b>	188002				
white background, black text	<b>P9ARPWM</b>	188028				
transparent	<b>P9ARPTM</b>	188019				



**Round plates for emergency**

		Diameter 59 mm			Diameter 78 mm			
		Description	Cat. no.	Ref. no.	Description	Cat. no.	Ref. no.	
Without text	yellow background		<b>080XTGR</b>	179514	black background	<b>080XTG8</b>	179515	
With text	yellow background	EMERGENZA	<b>080XTGR01</b>	179525	black background	EMERGENZA	<b>080XTG801</b>	179535
		EMERGENCY STOP	<b>080XTGR02</b>	179526		EMERGENCY STOP	<b>080XTG802</b>	179536
		ARRET D'URGENCE	<b>080XTGR03</b>	179510		ARRET D'URGENCE	<b>080XTG803</b>	179511
		NOT - AUS	<b>080XTGR04</b>	179527		NOT - AUS	<b>080XTG804</b>	179537
		NOODSTOP	<b>080XTGR05</b>	179528		NOODSTOP	<b>080XTG805</b>	179538
		PARO EMERGENCIA	<b>080XTGR06</b>	179529		PARO EMERGENCIA	<b>080XTG806</b>	179539
		NOTSTOP	<b>080XTGR07</b>	179530		EMERGENZA GENERALE	<b>080XTG807</b>	179540
		PARAGEM EMERGÈNCIA	<b>080XTGR08</b>	179531		PARAGEM EMERGÈNCIA	<b>080XTG808</b>	179541

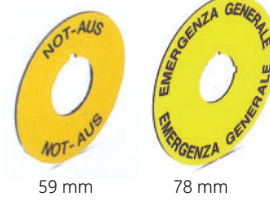

**Neutral plate**

		Description	Cat. no.	Ref. no.
	Snap-on system	For identification of contact blocks and power supplies	P9ACPIU	188016

**Adapter ring**

		Description	Cat. no.	Ref. no.
		Adapter ring for 30mm hole to mount P9 22mm in a 30mm hole	P9ARAM32	188801

(1) Other languages on request. The catalogue numbers in bold are available from stock.





Notes

Grid of dotted lines for notes.

Push-button stations

Intro

A

B

C

D

E

F

G

H

I

J/X



Dimensional drawings

Round operators - Push-buttons

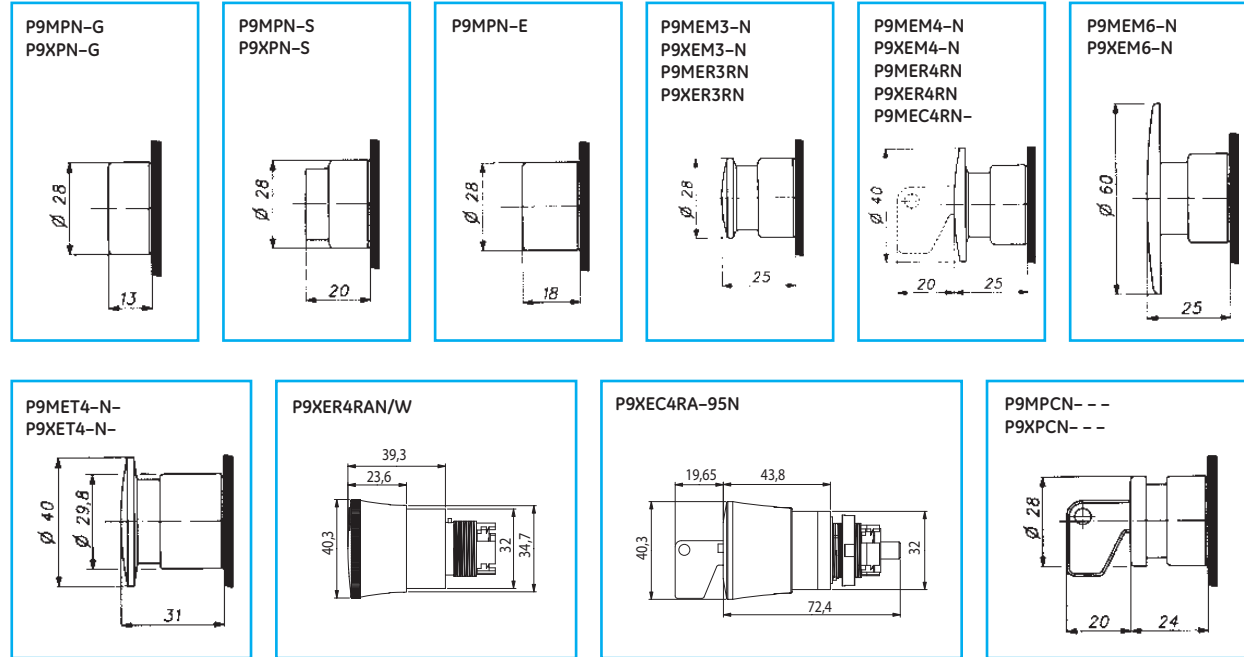

Round operators - Selector switches

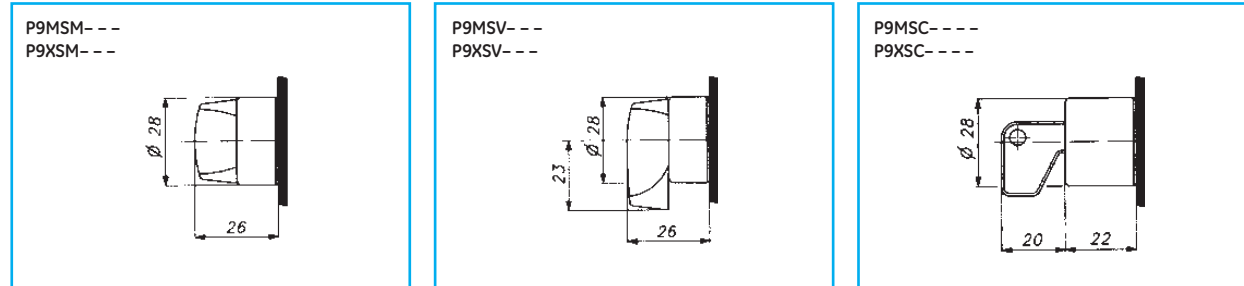

Round operators - Illuminated push-buttons and selector switches

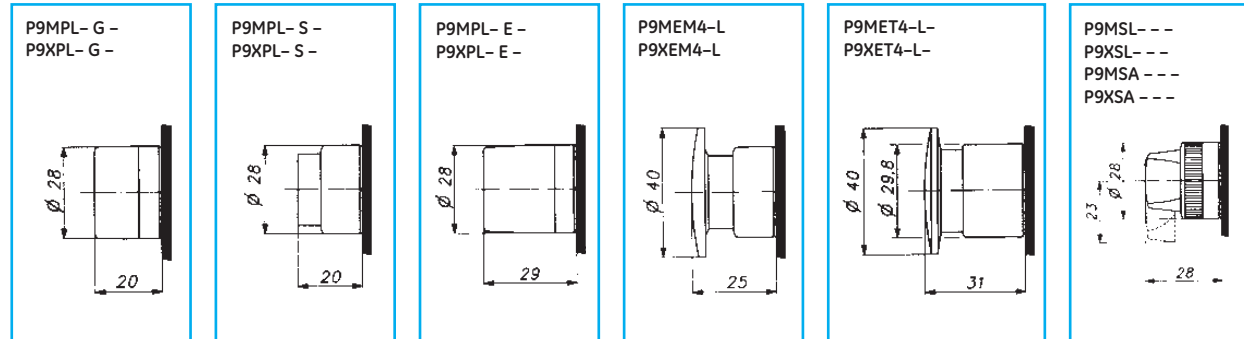

Round operators - Pilot lights

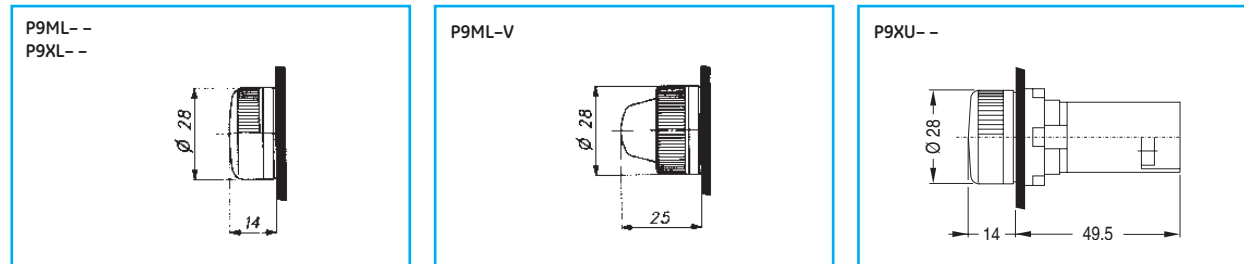



Round operators - Other devices

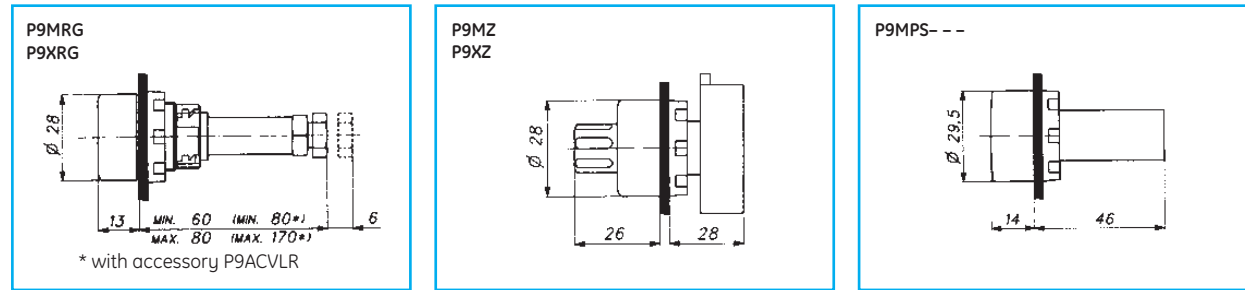
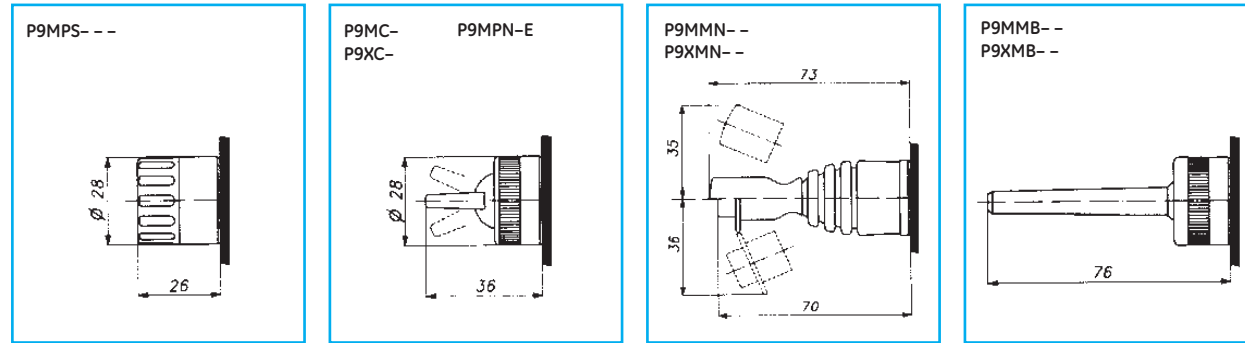

Square operators - Push-buttons

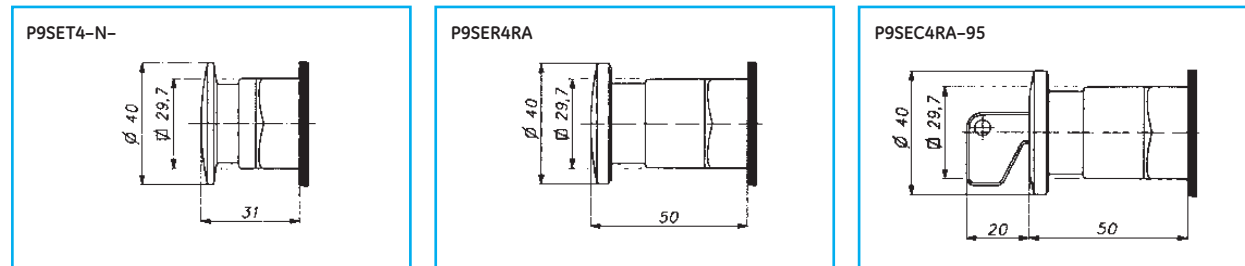
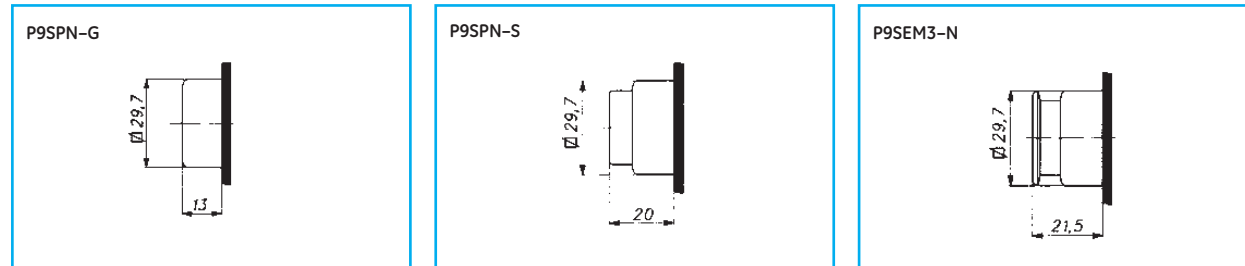

Square operators - Double function push-buttons

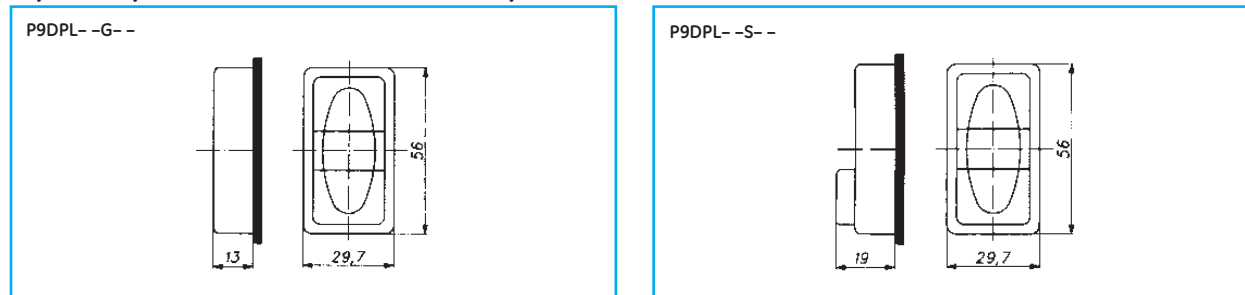

Dimensions

Intro

A

B

C

D

E

F

G

H

I

J/X



**Dimensional drawings**

**Square operators - Selector switches**

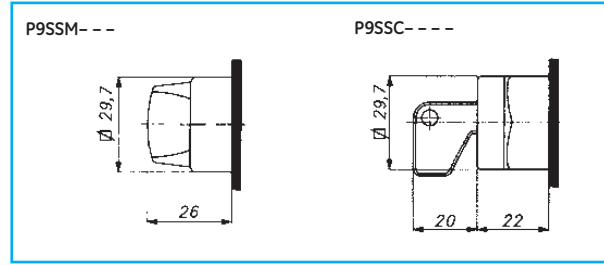

**Square operators - Pilot lights**

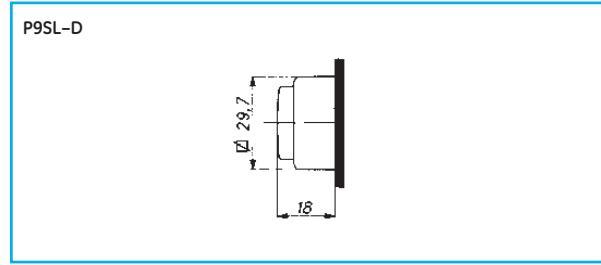

**Square operators - Illuminated push-buttons and selector switches**

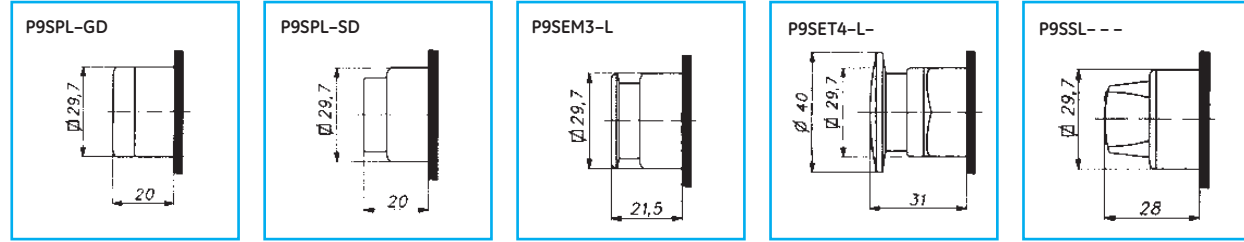

**Square operators - Other devices**

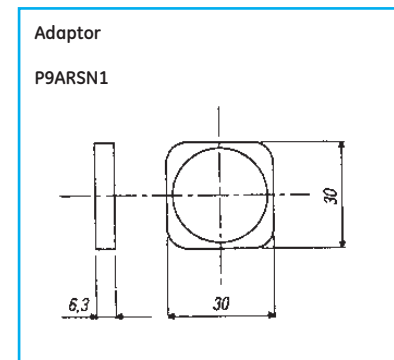
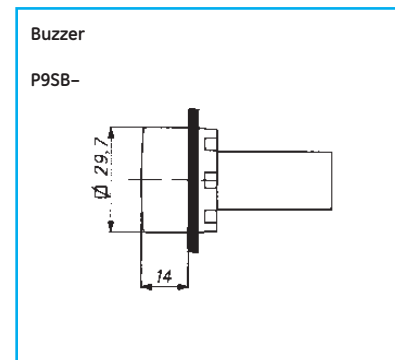
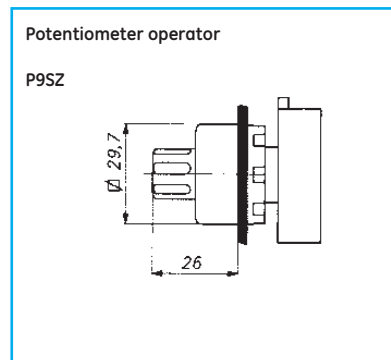
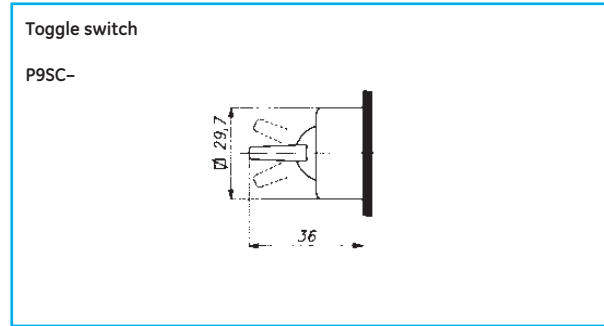

Contact blocks

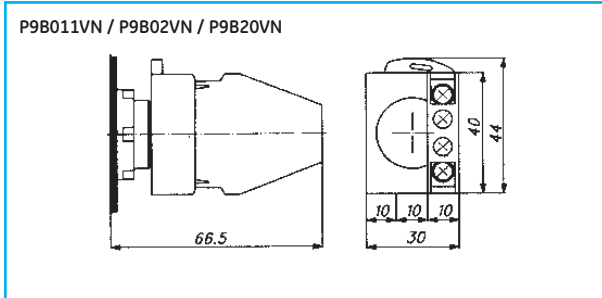
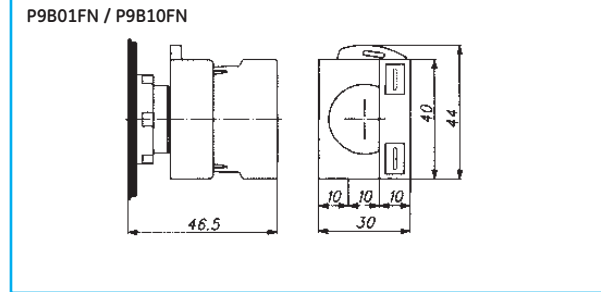
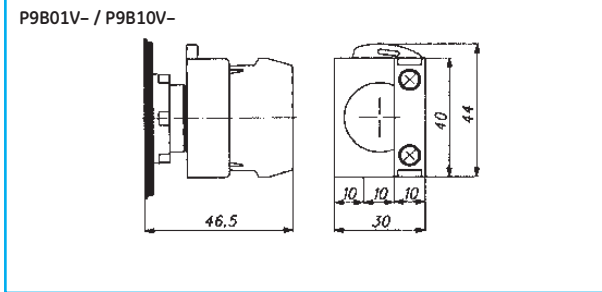

Power supplies

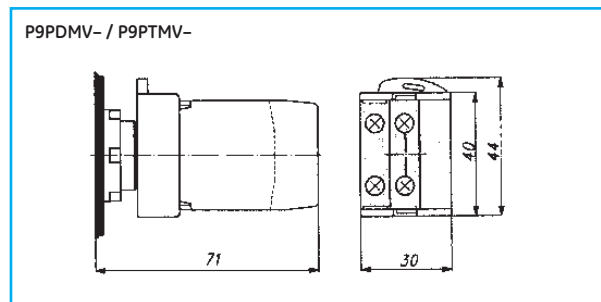
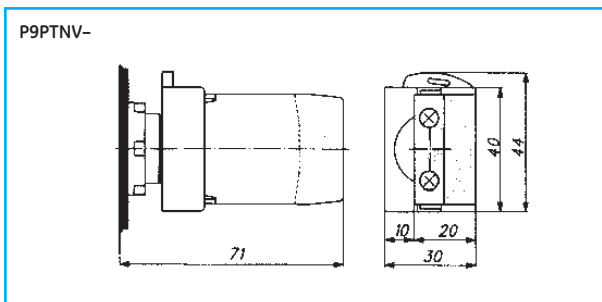
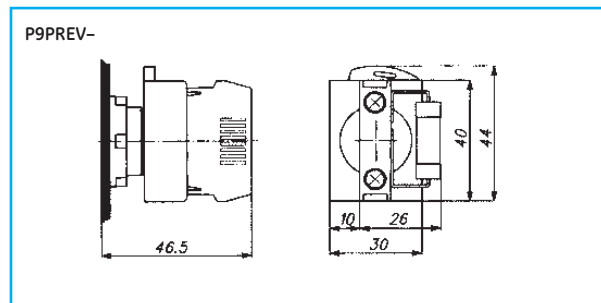
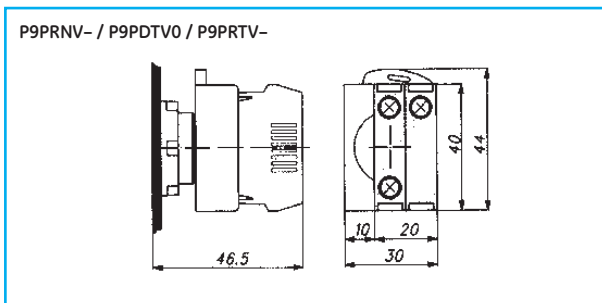
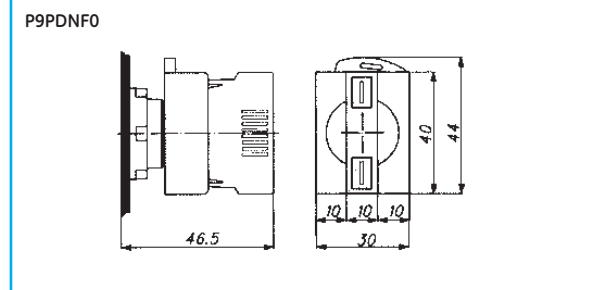
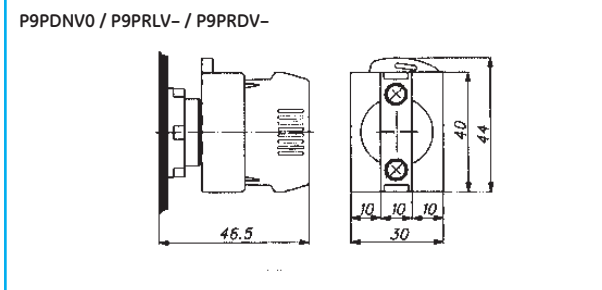

Dimensions

Intro

A

B

C

D

E

F

G

H

I

J/X



**Dimensional drawings**

**Push-on / push-off devices**

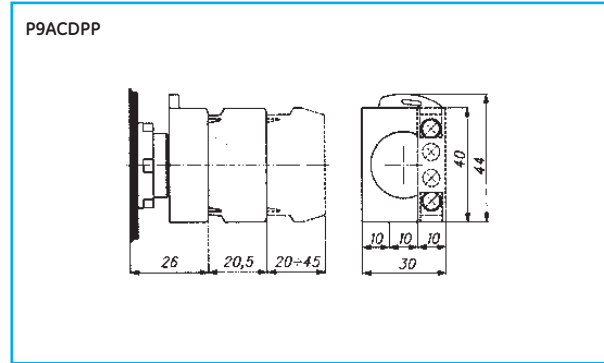

**Protection cover**

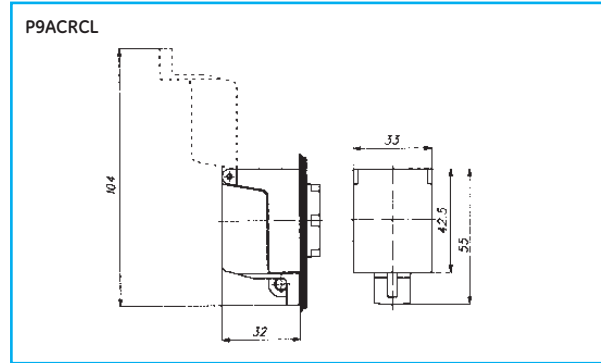

**Insert holders and plates**

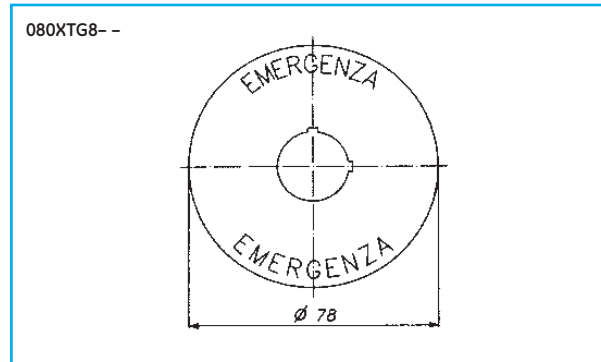
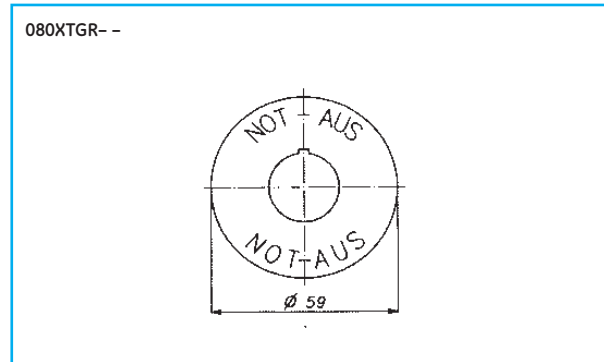
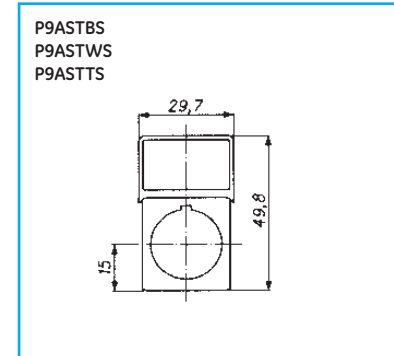
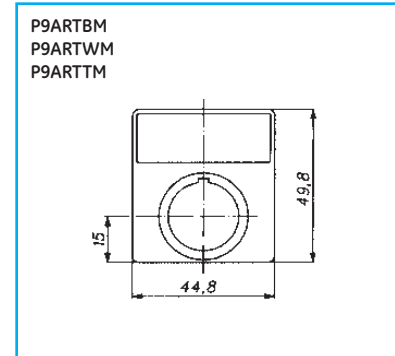
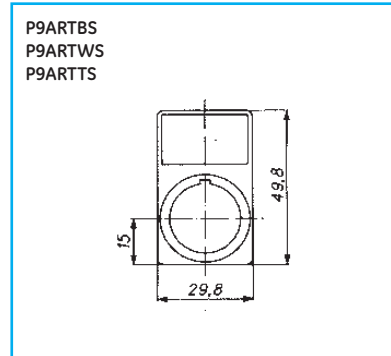

**Contact blocks**

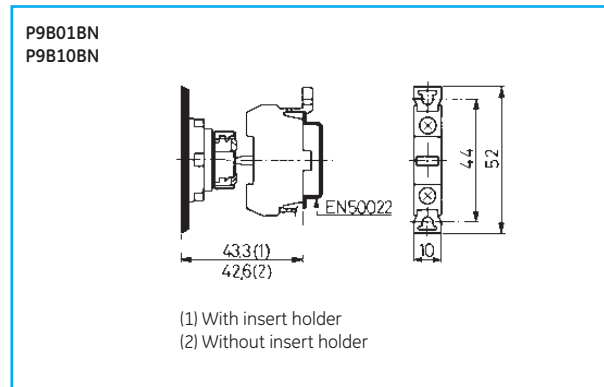

**Power supplies**

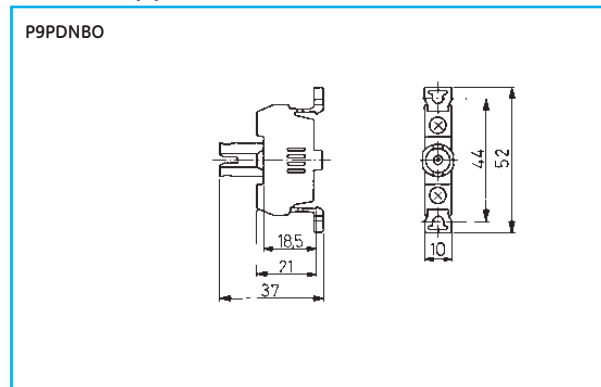

Intro

A

B

C

D

E

F

G

H

I

J/X



Overall dimensions

Enclosures for push-button stations in thermoplastic

Holes	A	B	C	E1	E2	H
1	72	46	16.5	23 <sup>(1)</sup>	15.5	57
2	110	78	16.5	23 <sup>(1)</sup>	21.5	95
3	140	108	16.5	23 <sup>(1)</sup>	21.5	125
4	175	143	16.5	23 <sup>(1)</sup>	21.5	160
6	235	200	19.5	29 <sup>(2)</sup>	23	220

(1) Suitable for cable gland, with locknut, PG16 or 1/2" NPT  
 (2) Suitable for cable gland, with locknut, PG21 or 3/4" NPT  
 (3) Flush push-button: 13  
 Pilot light: 14  
 Emergency push-button: 50  
 Key selector switch: 22  
 For customized versions see operator dimensions.

Enclosures for push-button stations in aluminium

Type	Holes Ø 22		Dimensions						Fixing templates	
	vertic.	horizont.	A (mm)	B (mm)	C (mm)	D (mm)	E (mm)	F	HxLxØmax (mm)	position of the holes
1	1	-	87	87	75	72	21.5	PG 21	74x55x4	1-3
1M	1	-	87	87	100	97	21.5	PG 21	68x55x4	1-3
2	2	-	145	87	75	72	21.5	PG 21	132x55x4	1-3
2M	2	-	145	87	100	97	21.5	PG 21	126x55x4	1-3
3	3	-	195	87	100	97	21.5	PG 21	176x55x4	1-3
4	2	2	145	87	75	72	21.5	PG 21	132x55x4	1-3
4M	2	2	145	87	100	97	21.5	PG 21	126x55x4	1-3
6	3	2	195	87	100	97	21.5	PG 21	176x55x4	1-3
8	2	4	152	152	101.5	98.5	27	PG 29	136x119x6	1-3
12	3	4	205	230	101.5	98.5	27	PG 29	172x214x6	1-2-3-4
18	3	6	257	300	101.5	98.5	35	PG 36	221x282x6	1-2-3-4
24	4	6	257	300	101.5	98.5	35	PG 36	221x282x6	1-2-3-4
35	5	7	350	350	123	106.5	41	PG 36	180x180x10	1-2-3-4

Dimensions

Intro

A

B

C

D

E

F

G

H

I

J/X



## Technical data

### Compliance with standards

IEC 947.5.1 - VDE 0660 - NFC 63140  
 CEI EN 60947.5.1 - UTE - BSI - NEMA  
 CENELEC EN 50007

### Approvals

UL (U.S.A.) - CSA (Canada) - RINA - CE

### Climatic protections

The standard versions are suitable for use in the following climates:

Temperate climate	cat. 23/50 (DIN 50014)
Wet climate	cat. 23/83 (DIN 50015)
Hot wet climate	cat. 40/92 (DIN 50015)
Variable wet climate	FW24 (DIN 50016)

### Temperature ranges

Operation	-25 °C to + 70 °C
Storage	-40 °C to + 70 °C

### Protection degree of the operators

IP65 according to IEC 529 when they are mounted into enclosures with the same or a higher degree of protection. IP66 with appropriate protective caps.

### Protection degree of the terminals

IP2x according to IEC 529.  
 Fully integrated on signalling units, illuminated push-buttons and illuminated selector switches. With accessory on contact blocks for control units.

### Rated insulation voltage

690V according to EN 60947.1

### Impulse withstand voltage

4 kV according to EN 60947.1

### Insulation class

Group C according to VDE 0110

### Electric shocks protection

Class I according to IEC 536

### Short-circuit protection

With fuses type gI of 10A according to IEC 947.5.1

### Connection terminals

Connection terminals  
 Screw type with retractable clamp.  
 Clamping capacity of rigid and/or flexible conductors:  
 - minimum 22 AWG (0.32 mm<sup>2</sup>)  
 - maximum 12 AWG (3.3 mm<sup>2</sup>)

### Performances of the contacts

- Slow acting
- Self-cleaning
- NC forced breaking
- Double break

### Electrical performances

Rated thermal current I<sub>th</sub> = 10 A

#### Performances according IEC 947.5.1

Categorie AC 15 (A600)		24	48	60	110	220	380	500	600
Voltage	U <sub>e</sub> (V)	24	48	60	110	220	380	500	600
Current	I <sub>e</sub> (A)	10	10	10	6	3	2	1.5	1.2
Categorie DC 13 (P600)		24	48	60	110	220	300	500	600
Voltage	U <sub>e</sub> (V)	24	48	60	110	220	300	500	600
Current	I <sub>e</sub> (A)	5	2.7	2	1.1	0.55	0.3	0.22	0.2
Categorie DC 13 (Q300) for illuminated push-buttons and illuminated selector switch		24	48	60	110	220	300		
Voltage	U <sub>e</sub> (V)	24	48	60	110	220	300		
Current	I <sub>e</sub> (A)	2.5	1.1	1	0.55	0.27	0.2		

#### Performances according to CSA and UL

AC Heavy Duty (A600)	
DC Standard Duty (Q300)	for illuminated push-buttons and illuminated selector switch

### Electrical endurance

Alternative current 50/60 Hz cat. AC 15

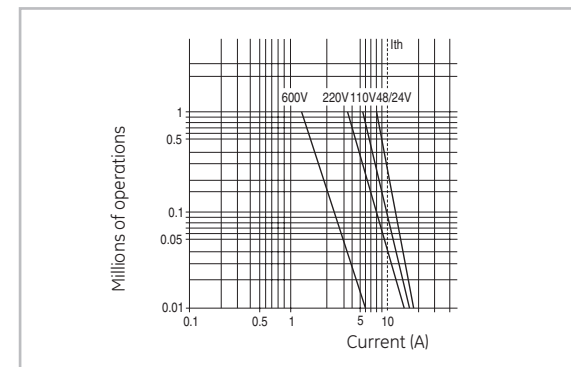

Direct current cat. DC 13

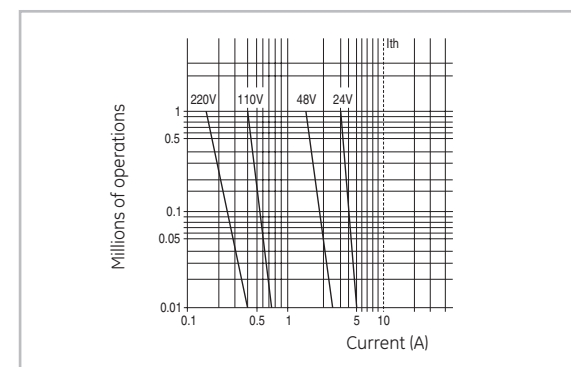

**Mechanical endurance**

Joysticks	
Key push-buttons	0.5 x 10 <sup>6</sup> op.
Locking mushroom push button	
Knob selector switches	
Lever selector switches	
Key selector switches	
Illuminated selector switches	1 x 10 <sup>6</sup> op.
Selector push-buttons	
Timed push-buttons	
Illuminated push-buttons	
Momentary std push-buttons	
Momentary mush. push-buttons	3 x 10 <sup>6</sup> op.

**Number of contact blocks**

Momentary standard push-buttons	4 double pole
Momentary mush. push-buttons	(8 single pole)
Key push-buttons	4 double pole
Locking emergency	(4 single pole)
Selector switches	6 double pole
(4 pos. types excl)	(6 single pole)
4 pos. selector switches	2 double pole
Selector push-buttons	6 double pole
	(6 single pole)
Joysticks 2 and 4 positions	4 double pole
	(4 single pole)
Illuminated push-buttons	For different contacts configuration, contact our sales office
Illuminated selector switches	

**Fitting of units**

The units of Series 077 are designed for fitting onto panels with a thickness between 1 and 7 mm., with holes of 30.5 mm. diameter, according to rules established by EN 60947.5.1.

A special metal ring supplied with each unit or one of the name plates included among the fittings, enables the unit to be exactly positioned.

All equipment is supplied with a set of spacing rings to adjust variations in the thickness of the panel thus ensuring a uniform front protrusion.

For a correct fitting, it needs to observe the diagram below and tables indications.

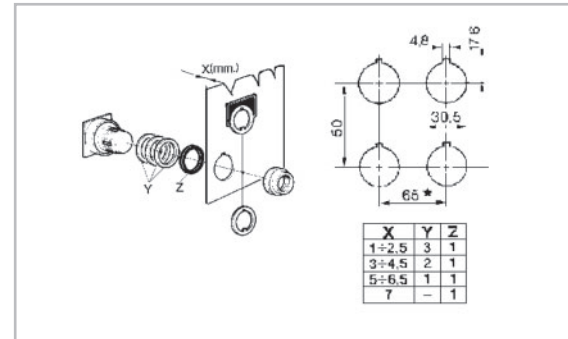

Control and signalling units Ø 30 mm

Intro

A

B

C

D

E

F

G







H

I

J/X



Push-buttons

Standard/Momentary	Description	Contacts	Cat. no.	Ref. no.
		NC+NO	<b>077P11</b>	180019
		NC	<b>077P01</b>	180039
		NO	<b>077P10</b>	180029
Standard/Time delayed (1)	Description	Contacts	Cat. no.	Ref. no.
	Contacts delayed at the release of the push button. Accuracy ± 5% Setting range: 0,1 - 30 sec. 10 - 180 sec.	NC+NO	077P11T30	180120
		NC+NO	077P11T180	180121
To complete by	Fixing kits			
	With 4 coloured caps: black, red, green, yellow	Ring type with guard	<b>077GGBCN</b>	<b>180020</b>
		without guard	<b>077GSBCN</b>	<b>180010</b>
	With 4 coloured caps: brown, orange, blue, white	Ring type with guard	<b>077GGBCS</b>	180050
		without guard	077GSBCS	180040
	With 1 clear and 4 marking etched on both sides	Ring type with guard	077GGBCF	180137
		without guard	077GSBCF	180136
				





(1) Not approved by RINA and Lloyd's Register

The catalogue numbers in **bold** are available from stock.

For reference numbers, see chapter X, pg. X.8

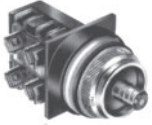

Push-buttons

Mushroom head/Momentary	Description	Contacts	Cat. no.	Ref. no.
		NC+NO	<b>077E11</b>	180049
		NC	<b>077E01</b>	180069
		NO	<b>077E10</b>	180059
Mushroom head with latch				
	Push-twist to release	NC+NO	<b>077RE11</b>	<b>180079</b>
		NC	<b>077RE01</b>	<b>180099</b>
		NO	<b>077RE10</b>	180089
With keylock <sup>(1)</sup>				
  (type G unlock)	<b>Key withdrawable in positions I &amp; II</b>			
	Lockable in position: normal & depressed	NC+NO	<b>077PC11C</b>	180100
	depressed without pre-setting <sup>(2)</sup>	NC+NO	<b>077PC11G</b>	180104
To complete by	Description	Diameter	Cat. no.	Ref. no.
	Mushroom head caps			
	For momentary push-button	Ø 35 mm	<b>077E●</b>	see bottom
		Ø 60 mm	<b>077EE●</b>	see bottom
	For push-twist to release push-button	Red Ø 35 mm	<b>077RER</b>	180090
		Red Ø 60 mm	<b>077RER60</b>	180091
	For keylock push-button	Red Ø 60 mm	<b>077ECR</b>	181602

The catalogue numbers in **bold** are available from stock.

Colours	black	red	yellow
	●	<b>N</b>	<b>R</b>
			G

- (1) Supplied with two standard keys 3095.
- (2) Combined with mushroom head 077ECR makes an mushroom head with latch push-key to release.

For reference numbers, see chapter X, pg. X.8

Push-buttons

Intro

A

B

C

D

E

**F**

G







H

I









J/X

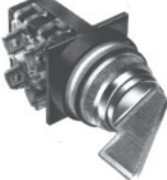

Selector switches with knob

2 positions		Function (1)	Contacts	Cat. no.	Ref. no. see bottom
	Fixed		D	NC+NO	<b>077SDN11</b> 180170
			H	NC+NO	077SHN11 180180
3 positions					
	Fixed		B	NC+NO	<b>077SBN11</b> 180230
			U	2NC+2NO	<b>077SUN22</b> 180440
			Z	2NC+2NO	<b>077SZN22</b> 180480
With spring return			B	NC+NO	077SBN11SC 180240
			B	NC+NO	077SBN11DC 180250
			B	NC+NO	<b>077SBN11RC</b> 180260
				2NC + 2NO	<b>077SN22RC</b> 180510

Selector switches with lever

2 positions		Function (1)	Contacts	Cat. no.	Ref. no.
	Fixed		D	NC+NO	<b>077SLD11</b> 180601
3 positions					
	Fixed		B	NC+NO	<b>077SLB11</b> 180607
			Z	2NC+2NO	077SLZ22 180623
	With spring return			Z	2NC+2NO
Z				2NC+2NO	<b>077SLZ22RC</b> 180626
4 positions					
	Fixed		X	2NC+2NO	<b>077SLX22</b> 180606

The catalogue numbers in **bold** are available from stock.

(1) Electrical diagrams, see F.55

For reference numbers, see chapter X, pg. X.8



Selector switches with key <sup>(1)</sup>

2 positions		Function (2)	Contacts	Key removal	Cat. no.	Ref. no.	
Fixed		D	NC+NO NC+NO NC+NO	I II I-II	<b>077SCD1101</b> 077SCD1105 <b>077SCD1109</b>	180630 180631 180632	
		With spring return	I	NC+NO	0	<b>077SCI11DC03</b>	180640
			H	NC+NO	0	077SCH11SC03	180636
3 positions							
Fixed		B	NC+NO	I-0-II	<b>077SCB1120</b>	180843	
		With spring return	B	NC+NO	I-0	<b>077SCB11DC07</b>	180852
Z	2NC+2NO		I	077SCZ22DC01	180906		
B	NC+NO		0	<b>077SCB11RC03</b>	180853		

The catalogue numbers **in bold** are available from stock.

(1) Supplied with two standard keys 3095.  
 (2) Electrical diagrams, see F.55

For reference numbers, see chapter X, pg. X.8

Selector switches

Intro

A

B

C

D

E

**F**

G





H

I

J/X

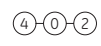

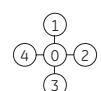
**Joysticks**

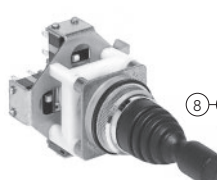
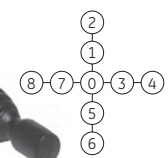
2 positions + central zero position		Function <sup>(1)</sup>	Contacts	Cat. no.		Ref. no.		
				Without interlock	With interlock			
 	Fixed position	N	2NC+2NO	<b>077MTS2422</b>	180910	<b>077MTS2422B</b>	181000	
		R	2NC+2NO	<b>077MTS2422R</b>	180912	<b>077MTS2422RB</b>	181002	
	Transient position	N	2NC+2NO	<b>077MT24S22</b>	180911	<b>077MT24S22B</b>	181001	
		R	2NC+2NO	<b>077MT24S22R</b>	180913	<b>077MT24S22RB</b>	181003	
4 positions + central zero position								
 	Fixed positions	N	2NC+2NO	<b>077MTS123422</b>	180914	<b>077MTS123422B</b>	181004	
	Transient positions		2NC+2NO	<b>077MT1234S22</b>	180915	<b>077MT1234S22B</b>	181005	
	2+2 positions + central zero position							
 	Fixed positions	X	4NC+4NO	077M2S2SX44	180918	077M2S2SX44B	181008	
	Transient positions		4NC+4NO	077M2T2TX44	180919	077M2T2TX44B	181009	
	4,8 transient -3,7 fixed			4NC+4NO	077M2S2TX44	180921		
	Transient positions	Y	4NC+4NO	077M2T2TY44	180923			
4+4 positions + central zero position								
 	Transient positions	X	8NC+8NO	077M4T4TX88	180927			
	2,4,6,8 transient -1,3,5,7 fixed			8NC+8NO	077M4S4TX88	180929	<b>077M4S4TX88B</b>	181019
	Transient positions	Y	8NC+8NO	077M4T4TY88	180931	<b>077M4T4TY88B</b>	181021	

The catalogue numbers **in bold** are available from stock.

(1) Electrical diagrams, see F.55

Intro

A

B

C

D

E

**F**

G





H

I

J/X



**Illuminated push-buttons**

Momentary	Description	Contacts	Cat. no.	Ref. no.
	Full voltage ~ / === BA9s max 380V - 2 W not included	NC+NO	<b>077PLM11D0</b>	181040
		NO+NO	<b>077PLM20D0</b>	181041
		NO	<b>077PLM10D0</b>	181043
	With transformer 50/60Hz BA9s6V-1.5W included	NC+NO	<b>077PLM11T♦</b>	
<b>To complete by:</b>				
<b>Lenses</b>				
	Standard		<b>077GPL</b> ♦	see bottom
	Mushroom head Ø 35 mm (to use with the fixing ring 077GG03)		<b>077GELR</b>	180971
	<b>Locking rings</b>			
	Without guard		<b>077GG03</b>	180980
	With metal guard		<b>077GGM</b>	180981
	With transparent guard		<b>077GGT</b>	180982

The catalogue numbers **in bold** are available from stock.

Suffix	110-120V	220-250V
♦	<b>J</b>	<b>N</b>

Colours	red	green	yellow	orange	blue	white	clear
Standard lenses	<b>R</b>	<b>V</b>	<b>G</b>	<b>A</b>	<b>BL</b>	<b>B</b>	<b>I</b>

For reference numbers, see chapter X, pg. X.8

Illuminated push-buttons

Intro

A

B

C

D

E

**F**

G











H

I

J/X



**Illuminated selector switches**

2 positions			Function (1)	Contacts	Cat. no.	Ref. no.
	Fixed		Full voltage ~ /  BA9s max. 380V-2W not included	D	NC+NO	<b>077ISD11D0</b> 181060
3 positions			Function (1)	Contacts	Cat. no.	Ref. no.
	Fixed		Full voltage ~ /  BA9s max. 380V-2W not included	B	NC+NO	<b>077ISB11D0</b> 181170
	With spring return		Full voltage ~ /  BA9s max. 380V-2W not included	B Z	NC+NO NC+NO	<b>077ISB11D0RC</b> 181174 <b>077ISZ11D0RC</b> 181176
<b>To complete by:</b>						
	Lenses					
	Knob				<b>077MIS●</b>	see bottom

(1) Electrical diagrams, see F.55

The catalogue numbers in **bold** are available from stock.

Suffix	110-120V	220-250V
◆	J	N

Colours	red	green	yellow
●	R	V	G

For reference numbers, see chapter X, pg. X.8

- Intro
- A
- B
- C
- D
- E
- F**
- G
- H
- I
- J/X



**Pilot lights**



Description	Cat. no.	Ref. no.
Full voltage ~ / $\equiv$ BA9s max. 380V-2W not included	<b>077LDNV0</b>	181300
With resistor ~ / $\equiv$ 110-120V, BA9s60V-1.2W included 220-240V, BA9s130V-2W included	<b>077LRNVJ</b> <b>077LRNVN</b>	181301 181302
With transformer 50/60Hz BA9s6v-1.5w included	<b>077LTNV♦</b>	
Multifunction (1) full voltage 24V ~ / $\equiv$ BA9s24V-2W included	<b>077LDMVD</b>	181305
Multifunction (1) with transformer 50/60 Hz BA9s6V-0.6W included	<b>077LTMV♦</b>	

To complete by:

Lenses	Cat. no.	Ref. no.
plastic version	<b>077GL●</b>	see bottom



Full voltage ~ / $\equiv$ For bulb E14 base max 660V(1)-6W not included	<b>077DLE14</b>	181260
--	-----------------	--------



To complete by:

Lenses	Cat. no.	Ref. no.
For pilot lights 077DLE14 plastic version	<b>099GW1●</b>	see bottom



The catalogue numbers in **bold** are available from stock.

Suffix	110-120V	220-250V
♦	<b>J</b>	<b>N</b>

Colours	red	green	yelloworange	blue	white	clear
●	<b>R</b>	<b>V</b>	<b>G</b>	<b>A</b>	<b>BL</b>	<b>B</b>
						<b>I</b>

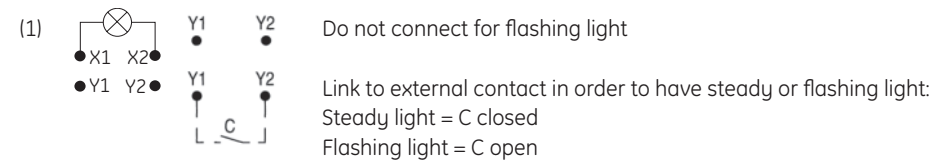

For reference numbers, see chapter X, pg. X.8

Pilot lights

Intro

A

B

C

D

E

**F**

G









H

I

J/X



Accessories

	Description	Cat. no.	Ref. no.				
	<b>Push-on/push-off device</b> For momentary standard push-buttons Converts momentary push-button to push-on/push-off. This device can only be used with 077-01 (NC) and/or 077-10A (NO early make) contact blocks.	077DPP	181550				
	<b>Push-pull to release device</b> For momentary mushroom push-buttons Converts momentary mushroom push-button to push to latch/pull to release.	077DAE	181554				
	<b>Handles</b> Knob for selector switches	077M●	see bottom				
	<b>Protection</b> Guard-ring for mushroom head push-button dia 35 mm.	077GE35	181620				
	<b>Plug</b> For unused mounting hole.	077TPF	181601				
	<b>Potentiometer operator</b> Suitable for potentiometers with shaft 50 mm long and 6 mm diameter. Potentiometer not included.	077OP2	181570				
	<b>Rubber protective caps</b> For standard push-buttons - coloured - clear	077CP●	see bottom				
		077CPT	181588				
	For illuminated standard push-buttons - clear	077CPLT	181600				
	For knob selector switches - black colour with clear knob	077CST	181603				
	<b>Spare keys</b> Standard version	Code					
		3095	077C3095 173095				
	<b>Bulbs BA9s</b>	Filament type	Vn	Wn			
			6	0.6	<b>BA9S606</b>	187850	
			6	1.5	<b>BA9S615</b>	187851	
			12	2	BA9S122	187852	
			24	2	<b>BA9S242</b>	187853	
			30	2.1	<b>BA9S30</b>	187854	
			48	2	BA9S48	187855	
			60	1.2	BA9S6012	187856	
			130	2	<b>BA9S130</b>	187857	
			Neon type	110	0.11	BA9SN110	187860
				220	0.33	<b>BA9SN220</b>	187861

The catalogue numbers in **bold** are available from stock.





Colours ●	black	red	green	yellow	blue	white
Knobs	N	R	V	G	BL	-
Protective caps	<b>N</b>	<b>R</b>	<b>V</b>	G	-	-
Mono LED	-	R	V	G	BL	B

For reference numbers, see chapter X, pg. X.8











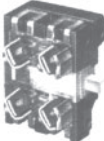
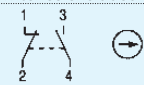

**Nameplates**

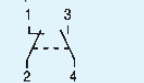
	Description	Cat. no.	Ref. no.
	For push-button and pilot lights Without text (black background)	077TNA	181650
	With text in English (black background)  STOP	077TNA40	181840
	For 2 position selector switch and selector push-button Without text (black background)	077TNA2	181660
	With text (black background) ON - OFF	077TNA230	181930
	For 3 position selector switch and selector push-button Without text (black background)	077TNA3	181670
	With text (black background) MANUAL CYCLE-O-AUTOMATIC	077TNA301	181951
	OPEN - OFF - CLOSE	077TNA312	181962
	UP - OFF - DOWN	077TNA313	181963
	Diameter 62 mm for emergency push-buttons Without text (yellow background)	077TGR	181720
	With text (yellow background): EMERGENCY STOP	077TGRO2	181722

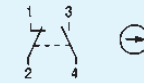
**Contact blocks**

2 positions	Contacts	Cat. no.	Ref. no.	
	<b>For all the applications</b> Illuminated push-buttons and illuminated selector switches excluded			
	<b>Standard</b> 	NC+NO	<b>077-11</b> 180001	
		NC	<b>077-01</b> 180003	
		NO	<b>077-10</b> 180002	
		NC late opening	<b>077-01R</b> 180008	
		NO early closing	<b>077-10A</b> 180007	
	<b>Accessories for contact blocks 077-...</b> IP2X protection	for use with NO for use with NC for use with NO+NC	<b>077PTB10</b> 181608 <b>077PTB01</b> 181609 <b>077PTB11</b> 181615	
	<b>For 2 + 2 and 4 + 4 positions joysticks</b> Snap action 		099SPDDB 180009	
		<b>For illuminated push-buttons and illuminated selector switches</b> 	NC+NO	P9B11VN 187000
			NC	P9B01VN 187001
		NO	P9B10VN 187002	

The catalogue numbers in **bold** are available from stock.

**Accessoires**

Intro

A

B

C

D

E

**F**

G

H

I

J/X



Enclosures for push-button stations in aluminium alloy (Grey RAL 7012)

Control and signalling units Ø 30 mm

Intro

A

B

C

D

E

F

G

H

I

J/X

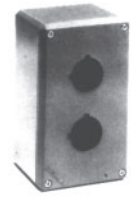

Cover with holes with conduit entry

No. of holes	Type	Cat. no.	Ref. no.
1	1	<b>077SP1</b>	180521
1	1M	<b>077SP1M</b>	180522
2	2	<b>077SP2</b>	180523
2	2M	<b>077SP2M</b>	180524
3	3	<b>077SP3</b>	180525
4	4V	<b>077SP4V</b>	180526
4	4	<b>077SP4</b>	180527
6	6	<b>077SP6</b>	180528
9	9	<b>077SP9</b>	180529
12	12	<b>077SP12</b>	180530
16	16	<b>077SP16</b>	180531
20	20	<b>077SP20</b>	180532
25	25	<b>077SP25</b>	180533
30	30	<b>077SP30</b>	180534
36	36	077SP36	180535

Cover with holes without conduit entry

No. of holes	Type	Cat. no.	Ref. no.
1	1	077SP1SFE	180536
1	1M	077SP1MSFE	180537
2	2	077SP2SFE	180538
2	2M	077SP2MSFE	180539
3	3	077SP3SFE	180540
4	4V	077SP4VSFE	180541
4	4	077SP4SFE	180542
6	6	077SP6SFE	180543
9	9	077SP9SFE	180544
12	12	077SP12SFE	180545
16	16	077SP16SFE	180546
20	20	077SP20SFE	180547
25	25	077SP25SFE	180548
30	30	077SP30SFE	180549
36	36	077SP36SFE	180550

Cover without holes with conduit entry

Type	Cat. no.	Ref. no.
1	080SP1SFC	170835
1M	080SP1MSFC	170838
2	080SP2SFC	170841
2M	080SP2MSFC	170844
3	080SP3SFC	170847
4V	077SP4VSFC	180551
4	080SP8SFC	170853
6	080SP12SFC	170856
9	080SP12SFC	170856
12	080SP18SFC	170859
16	080SP18SFC	170859
20	080SP35SFC	170863
25	080SP35SFC	170863
30	<b>077SP36SFC</b>	180552
36	077SP36SFC	180552

Cover without holes without conduit entry

Type	Cat. no.	Ref. no.
1	080SP1SF	170837
1M	080SP1MSF	170840
2	080SP2SF	170843
2M	080SP2MSF	170846
3	080SP3SF	170849
4V	077SP4VSF	180553
4	080SP8SF	170855
6	080SP12SF	170858
9	080SP12SF	170858
12	080SP18SF	170861
16	080SP18SF	170861
20	080SP35SF	170865
25	080SP35SF	170865
30	<b>077SP36SF</b>	180554
36	077SP36SF	180554

Accessories	Cat. no.	Ref. no.
Kit of two hinges for types from 12 to 36 holes.	<b>080KCSP</b>	170883

The catalogue numbers in bold are available from stock.





Diagrams

Selector switches

Diagram	Function	Contacts	Diagram
	D 077 11...		
	I 077 11...		
	H 077 11...		
	B 077 11...		
	Z 077 11... 077 11...		

Illuminated selector switches

Full voltage type	Function	Contacts	Diagram
	D 077 10... 077 01...		
	B 077 10... 077 01...		
	Z 077 10... 077 01...		

Joysticks

Positions	Function	Contacts	Diagram
	N 077 11... 077 11...		
	R 077 11... 077 11...		
	N 077 11... 077 11...		

Joysticks

Positions	Function	Contacts	Diagram
	X 077 11... 077 11... 077 11... 077 11...		
	Y 077 11... 077 11... 077 11... 077 11...		
	X 077 11... 077 11... 077 11... 077 11... 077 11... 077 11... 077 11... 077 11... 077 11... 077 11... 077 11...		
	Y 077 11... 077 11... 077 11... 077 11... 077 11... 077 11... 077 11... 077 11... 077 11... 077 11... 077 11...		

Diagrams

Intro

A

B

C

D

E

F

G

H

I

J/X

**Dimensional drawings**

**Push-buttons**

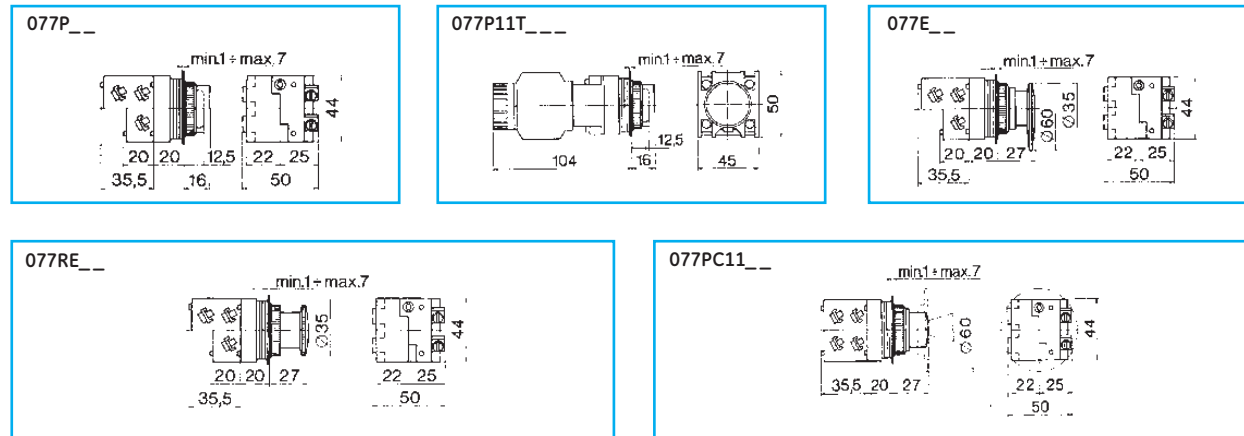

**Selector switches**

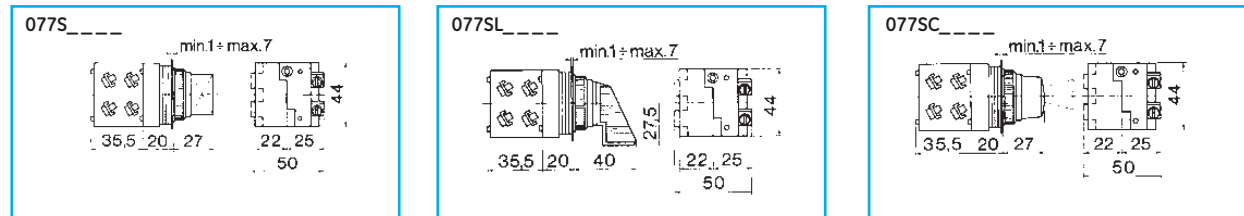

**Joysticks**

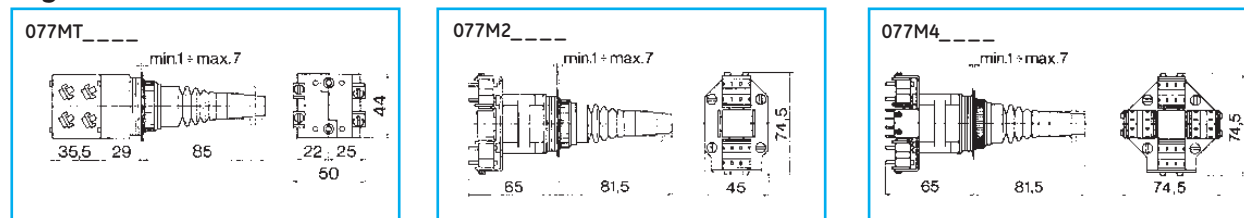

**Illuminated push-buttons**

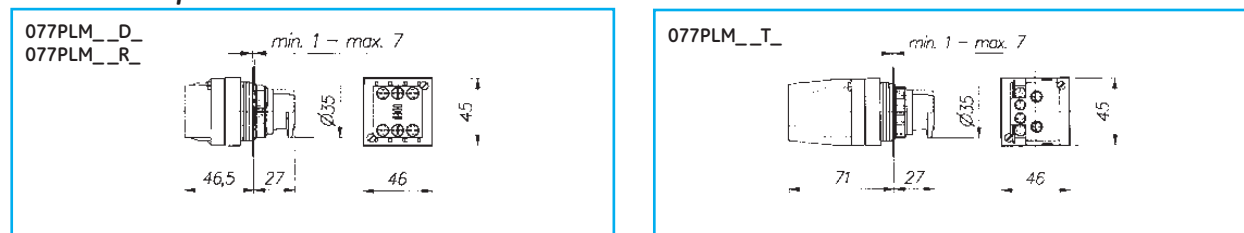

**Illuminated selector switches**

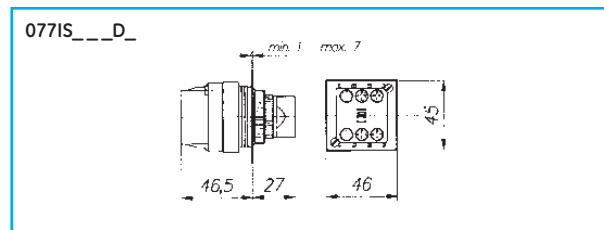

Pilot lights

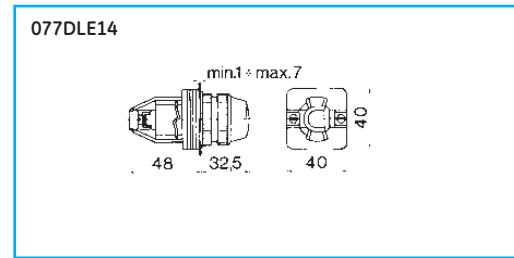
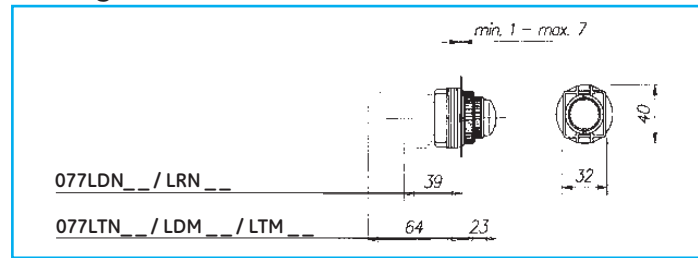

Kits

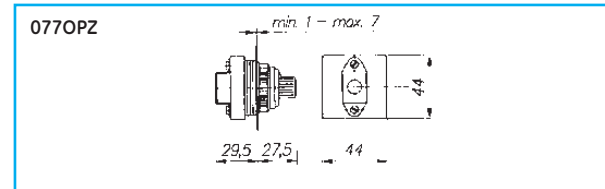
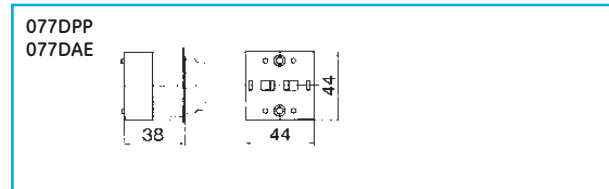

Nameplates

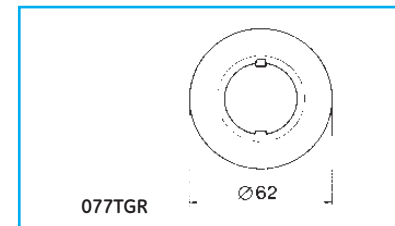
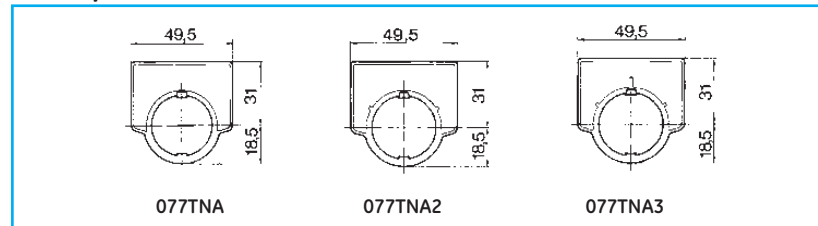

Contact blocks

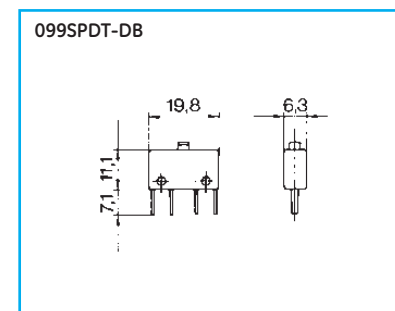
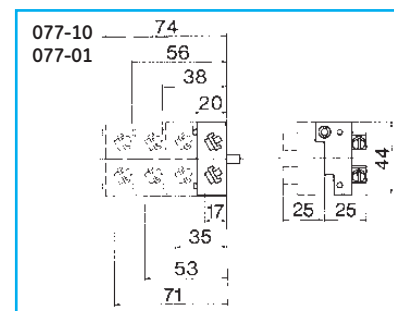
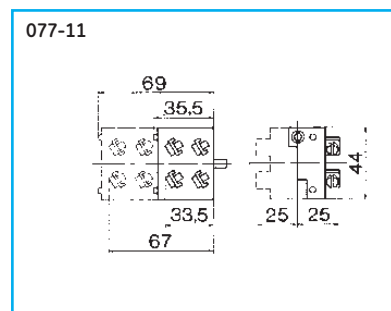

Dimensions

Intro

A

B

C

D

E

F

G

H

I

J/X



Dimensional drawings

Aluminium enclosures

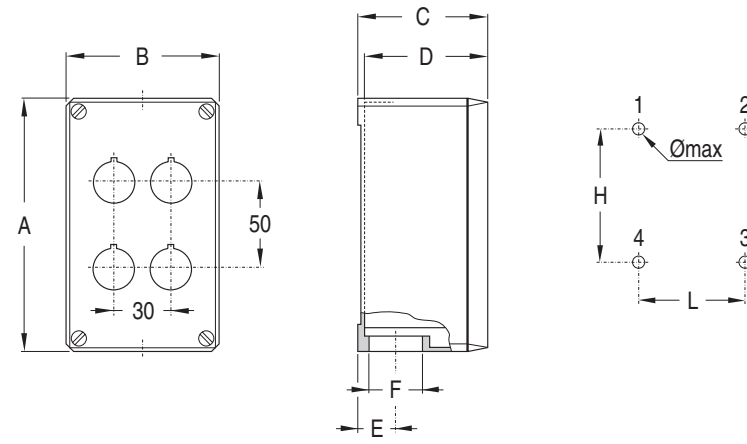

Type	Number of holes Ø 30		Dimensions						Fixing templates	
	Vertic.	Horizont.	A (mm)	B (mm)	C (mm)	D (mm)	E (mm)	F	HxLxØmax (mm)	position of the holes
1	-	-	87	87	75	72	21.5	PG 21	74x55x4	1 - 3
1M	-	-	87	87	100	97	21.5	PG 21	68x55x4	1 - 3
2	2	-	145	87	75	72	21.5	PG 21	132x55x4	1 - 3
2M	2	-	145	87	100	97	21.5	PG 21	126x55x4	1 - 3
3	3	-	195	87	100	97	21.5	PG 21	176x55x4	1 - 3
4V	4	-	257	92	86.5	83.5	23	PG 21	224x76x6	1 - 3
4	2	2	152	152	101.5	98.5	27	PG 29	136x119x6	1 - 3
6	2	3	205	230	101.5	98.5	27	PG 29	172x214x6	1-2-3-4
9	3	3	205	230	101.5	98.5	27	PG 29	172x214x6	1-2-3-4
12	3	4	257	300	101.5	98.5	35	PG 36	221x282x6	1-2-3-4
16	4	4	257	300	101.5	98.5	35	PG 36	221x282x6	1-2-3-4
20	5	4	350	350	123.5	106.5	41	PG 36	180x180x10	1-2-3-4
25	5	5	350	350	123.5	106.5	41	PG 36	180x180x10	1-2-3-4
30	6	5	410	410	144.5	127.5	53	PG 48	180x180x10	1-2-3-4
36	6	6	410	410	144.5	127.5	53	PG 48	180x180x10	1-2-3-4

- Control and signalling units Ø 30 mm
- Intro
- A
- B
- C
- D
- E
- F**
- G
- H
- I
- J/X



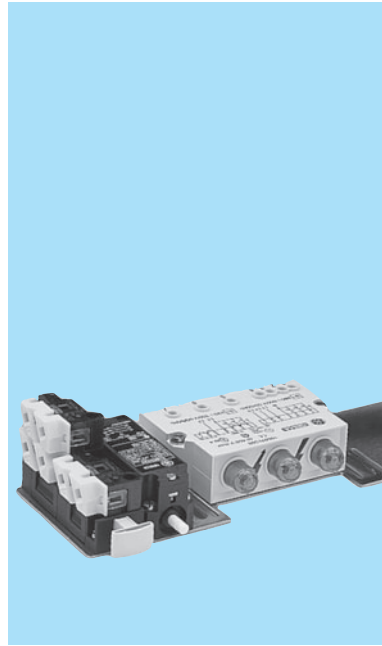

## Signalling devices

### General

Series 105 signalling units are used to indicate the electric equipment power supply conditions. For this purpose the devices shall be wired after the main disconnecting switch and clearly in view when the cabinet's doors are opened. Series 105 DTL devices can be used on three-phase lines with or without the neutral wire or single-phase power lines, indicating the hazardous condition due to the applied voltage. Three luminous red lamps are used. The flashing devices are normally used in combination with limit switches contacts NC type 114FCT03 that provides insertion when the cabinet door are open only.

### Climatic protection

The standard versions are suitable for use in the following climates:

- Temperate climate cat. 23/50 (DIN 50014)
- Wet climate cat. 23/83 (DIN 50015)
- Hot wet climate cat. 40/92 (DIN 50015)
- Variable wet climate cat. FW 24 (DIN 50016)

### Standards

CEI, IEC, VDE, BSI and UTE

### Approvals

CE, UL, CSA

### Suggested connections

Indicates the presence of 3, 2 or 1 phase only by means of the relative lamp.

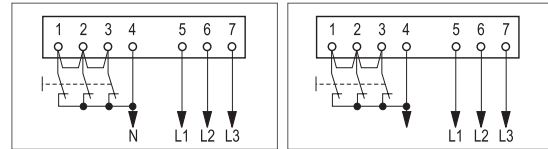

3-phase line with insulated neutral 3-phase line with grounded neutral

Indicates the presence of 3 or 2 phases by means of the relative lamp. One phase only is not indicated (all lamps OFF)

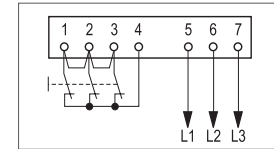

3-phase line without neutral

Indicates both phases with 3 lamps ON at same time. One phase only is not indicated (all lamps OFF)

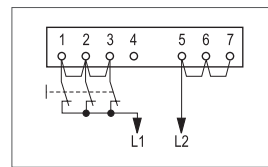

Single-phase line (general diagram)

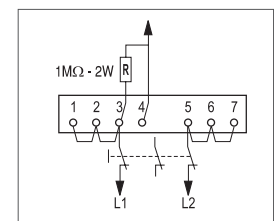

Single phase-line (alternative diagram)

1. Phase to phase connection on a 3 phase line with grounded neutral. Indicates the presence of 2-phases or 1 only with the 3 lamps ON at the same time.
2. Phase to neutral connection on a 3 phase line with grounded neutral or phase to phase by a matching transformer with one phase grounded. Indicates the presence of the ungrounded phase with the 3 lamps ON at the same time. No indication occur if the ungrounded phase is missing (all lamps OFF).

### Specifications

Temperature ranges	Operation	from -25°C up to +70°C
	Storage	from -40°C up to +70°C
Degree of protection (according to IEC 529)		IP 20
<b>Electrical</b>		
Rated insulation voltage according to EN 60947.1		690V
Impulse withstand voltage according to EN 60947.1		4kV
Electrical input		2mA max.
Connections		Terminal strip with numbered terminals, accessible from outside
		protected against accidental contacts according to DIN 57106 and IP 20 according to IEC 529
Clamping capacity		Maximum one flexible conductor 12 AWG (3.3mm <sup>2</sup> )

Signalling devices

Intro

A

B

C

D

E

F

G

H

I

J/X

Order codes ● pg. F.58  
Dimensional drawings ● pg. F.60



**Flashing devices**



Supply voltage		Cat. no	Ref. no.	Pack
Three-phase (50-60Hz)	Single-phase (50/60Hz)			
220V	110-127V	105DTL220	132230	1
380-600V	220-350V	105DTL500	132231	1
690V		105DTL690	132232	1

**3 pole limit switch for device control**



Protection degree	Cables entry	Operation force	Contacts	Cat. no	Ref. no.	Pack
IP40	PG11	8.5 N min.	3NC	114FCT03	130320	25
IP65	PG11	8.5 N min.	3NC	114FCT03T	130321	25

**Paralell bridge for 3 poles limit switches**



Cat. no	Ref. no.	Pack
105 PT	132234	50x5

**Single door protection unit**



The unit includes the following components:

- one flashing device 105DTL220 or 105DTL500.
- one 3-pole limit switch 114FCT03 for connection of the flashing device
- one electrical interlock device and panel light 105GIL or 105GIL10.
- one mounting plate 105PM on which are fitted on the above devices.

If two doors have to be protected (as double enclosure closing on the middle) the mounting plate shall be fitted also one limit switch 114FCT03 and one device 105GIL or 105GIL10.

**Approvals:**

UL (USA) - CSA (Canada)

Supply voltage			Cat. no	Ref. no.	Pack
Three-phase (50-60Hz)	Single-phase (50/60Hz)	Tripping coil			
220V	110-127V	Shunt trip	105GP1P220	132250	1
220V	110-127V	Undervoltage trip	105GP1P220M	132251	1
380-600V	220-350V	Shunt trip	105GP1P500	132252	1
380-600V	220-350V	Undervoltage trip	105GP1P500M	132253	1





**Electrical interlock device and cubicle lighting <sup>(1)</sup>**



The switch can be directly driven by the enclosure door.  
 If several doors are employed, one switch per door shall be used.  
 When properly connected, the following functions are provided:

- Position 1 (pushed) door closed: light OFF, tripping coil of main switch unpowered ( normal equipment operation )
- Position 2. (free) door opening: light ON, tripping coil of main switch powered (equipment shall cut-out automatically).
- Position 3 (pulled) door open: light ON, tripping coil of main switch unpowered (adjustment on the equipment of dry checks). When door is closed again, the switch revert automatically from position 2 or 3 to position 1.

Terminals have IP2X protection degree according to IEC/EN 60529

Approvals: UL (U.S.A.) - CSA (Canada)

Tripping coil	Cat. no	Ref. no.	Pack																
Shunt trip	105 GIL	132240	1																
<table border="1"> <tr> <td></td> <td>1</td> <td>2</td> <td>3</td> </tr> <tr> <td>E</td> <td>○</td> <td>○</td> <td>○</td> </tr> <tr> <td>F</td> <td>○</td> <td>○</td> <td>○</td> </tr> <tr> <td>G</td> <td>○</td> <td>○</td> <td>○</td> </tr> </table> 		1	2	3	E	○	○	○	F	○	○	○	G	○	○	○			
	1	2	3																
E	○	○	○																
F	○	○	○																
G	○	○	○																
Undervoltage trip	105 GIL 10	132241	1																
<table border="1"> <tr> <td></td> <td>1</td> <td>2</td> <td>3</td> </tr> <tr> <td>E</td> <td>○</td> <td>○</td> <td>○</td> </tr> <tr> <td>F</td> <td>○</td> <td>○</td> <td>○</td> </tr> <tr> <td>G</td> <td>○</td> <td>○</td> <td>○</td> </tr> </table> 		1	2	3	E	○	○	○	F	○	○	○	G	○	○	○			
	1	2	3																
E	○	○	○																
F	○	○	○																
G	○	○	○																

**Electrical interlock device <sup>(1)</sup>**



The switch is directly driven by the enclosure door.  
 If several doors are employed, one switch per door is needed.  
 When properly connected, the same functions of devices above shall be provided but without enclosure control light.  
 Terminals have IP2X protection degree according to IEC 529

Tripping coil	Cat. no	Ref. no.	Pack								
Shunt trip	105 CI	132242	1								
<table border="1"> <tr> <td></td> <td>1</td> <td>2</td> <td>3</td> </tr> <tr> <td>G</td> <td>○</td> <td>○</td> <td>○</td> </tr> </table> 		1	2	3	G	○	○	○			
	1	2	3								
G	○	○	○								
Undervoltage trip	105 CI 10	132243	1								
<table border="1"> <tr> <td></td> <td>1</td> <td>2</td> <td>3</td> </tr> <tr> <td>G</td> <td>○</td> <td>○</td> <td>○</td> </tr> </table> 		1	2	3	G	○	○	○			
	1	2	3								
G	○	○	○								

**Mounting plate**



Cat. no	Ref. no.	Pack
105 PM	132244	1

(1) For electrical performance and features of contact blocks please see F.42

Signalling devices

Intro

A

B

C

D

E

F

G

H

I

J/X



Dimensional drawings

Series 105 - Flashing devices

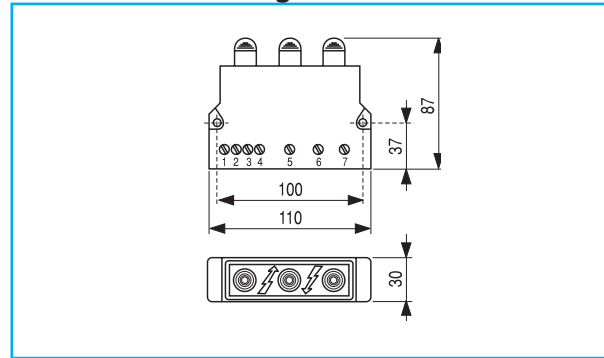

Series 105 - Single door protection unit

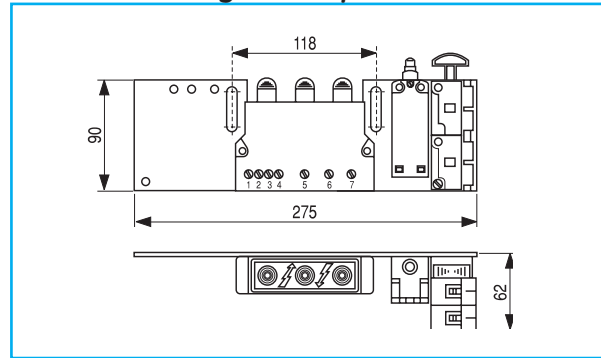

Series 105 - Electrical interlock and cubicle lighting

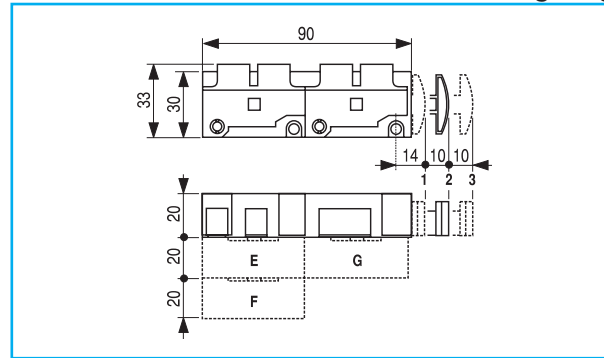

Series 105 - 3 pole limit switch for device control

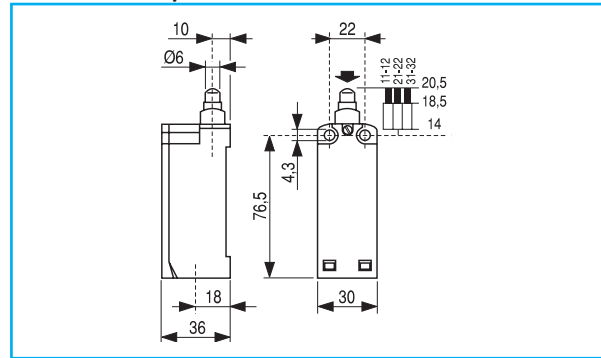

Series 105 - Electrical interlock device

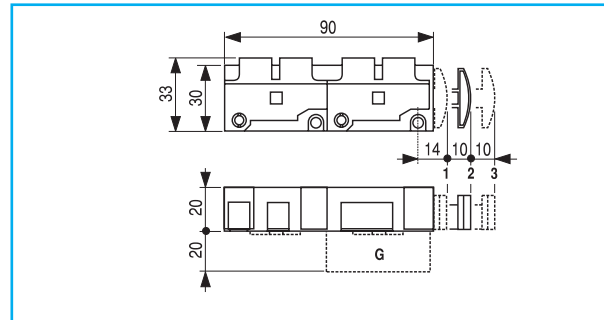

Series 105 - Mounting plate

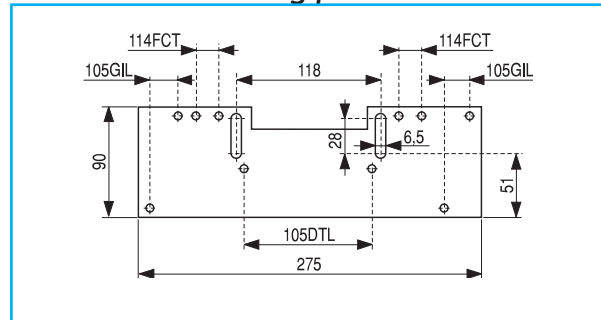

Signalling devices

Intro

A

B

C

D

E

F

G

H

I

J/X





Notes

Grid area for notes

Signalling devices

- Intro
- A
- B
- C
- D
- E
- F**
- G
- H
- I
- J/X









### Light towers

- Outstanding modular concept. One terminal unit can be combined with **up to seven modular signal units.**
- Steady light units, flashing light units, strobe light units, LED light units.
- The buzzer elements emit a clearly audible dual-tone signal for maximum safety.
- A bayonet mounting, through a simple manual operation, allows a quick and simultaneous method of joining the signal units together and the electrical connection of them.
- Compact dimension Ø70mm.
- IP65 for use in extreme conditions.
- Captive screw cable connectors, located with terminal unit are **easy** to reach and guarantee a quick and neat electrical connection.
- The special design makes maintenance quick, easy and carried out in complete safety and without tools.
- The high quality of materials used to manufacture the lenses ensures the light output is at the **highest luminous** intensity, combined with a sturdy construction and a good resistance to aging.

### Marking



### Meaning of optical signals

	Colour	Meaning	Operating state
	Red	Extreme danger Hazardous conditions	Immediate action necessary
	Yellow / Amber	Beware Warning conditions imminent	Abnormal state Monitor or action as necessary
	Green	Normal conditions	No actions required
	Blue	Conditions requiring defined action	Discontinuity Intervention mandatory
	White / Clear	No particular meaning	Other state Can be used as required

### Meaning of audible signals (EN 981, IEC 73)

	Signal tone	Meaning	Operating state
	Intermittent modulated tone	Danger	Immediate action necessary
	Linear tone	Safety	No actions required



Light units

**NLT1...** **Steady light unit**



- With socket BA15D for filament bulbs (7W max.) and LEDs
- Supply voltage: 240V AC/DC
- Current consumption (with 5W lamps):

24V	115V	240V
210mA	43mA	22mA

**NLT2...** **Flashing light unit**



- With socket BA15D for filament bulbs (7W max.) and LEDs
- Supply voltage: 24V AC/DC, 115V AC, 240V AC
- Current consumption (with 5W lamps):

24V DC	24V AC	115V AC	240V AC
130mA	145mA	25mA	15mA

**NLT3...** **Strobe light unit**

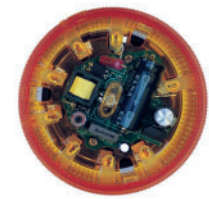

- Lamp type: 4 Joule xenon lamp
- Supply voltage: 24V AC/DC, 115V AC, 240V AC
- Current consumption:

24V DC	24V AC	115V AC	240V AC
75mA	135mA	20mA	15mA

- Flash frequency: 1,4Hz (84 flashes per min.) according with EN 60073

Audio units

**NLT73BD** **Pulsating tone**



- **Protection degree IP54**
- Tone: pulsating
- Audio frequency: 2900Hz
- Pulsating tone frequency: 0,5Hz according to EN 457
- Sound level at 1 m.: 90 dB (A)
- Supply voltage: 24V AC/DC
- Current consumption: 20mA

**NLT75AJ - NLT75AN** **Pulsating or constant tone**



Pulsating or constant tone, adjustable by removing or inserting bridge JP1 in the printed circuit.

- **Protection degree IP54**
- Tone: pulsating or constant
- Audio frequency: 2600Hz according to EN 457
- Pulsating tone frequency: 1Hz according to EN 457
- Sound level at 1 m.: pulsating tone: 95 dB (A) constant tone: 93 dB (A)
- Supply voltage: 115VAC (NLT75AJ) / 240VAC (NLT75AN)
- Current consumption:

115VAC	240VAC
40mA	30mA

**NLT75BD** **Modulated tone**



- **Protection degree IP54**
- Audio frequency: 2500 - 2800Hz according to EN 457
- Sound level at 1 m.: max. 90 dB (A)
- Supply voltage: 24V AC/DC
- Current consumption: 40mA

16 sounds can be selected by means of the dip switch

**NLT77BD** **Pulsating tone**



- **Protection degree IP65**
- Audio frequency: 1200 - 2600Hz according to EN 457
- Sound level at 1 m.: max. 84 dB (A)
- Supply voltage: 24V AC/DC
- Current consumption: 40mA

**NLT77AJ - NLT77AN** **Pulsating or constant tone**



Pulsating or constant tone, adjustable by removing or inserting bridge JP1 in the printed circuit.

- **Protection degree IP65**
- Tone: pulsating or constant
- Audio frequency: 2600Hz according to EN 457
- Pulsating tone frequency: 1Hz according to EN 457
- Sound level at 1 m.: pulsating tone: 78 dB (A) constant tone: 75 dB (A)
- Supply voltage: 115VAC (NLT77AJ) / 240VAC (NLT77AN)
- Current consumption:

115VAC	240VAC
40mA	30mA

Light towers

Intro

A

B

C

D

E

F

G

H

I

J/X



Light units

	Supply voltage	Red		Amber		Yellow		Green		Blue		Clear	
		Cat. no.	Ref. no.	Cat. no.	Ref. no.	Cat. no.	Ref. no.	Cat. no.	Ref. no.	Cat. no.	Ref. no.	Cat. no.	Ref. no.
<b>Steady light units</b> (bulb not included)	12...240V	NLT1R	222230	NLT1A	222231	NLT1G	222232	NLT1V	222233	NLT1L	222234	NLT1I	222235 1
<b>Flashing light units</b> (bulb BA15D filament) (bulb included)	24V AC/DC	NLT2BDR	222236	NLT2BDA	222237	NLT2BDG	222238	NLT2BDV	222239	NLT2BDL	222240	NLT2BDI	222241 1
	115V AC	NLT2AJR	222242	NLT2AJA	222243	NLT2AJG	222244	NLT2AJV	222245	NLT2AJL	222246	NLT2AJI	222247 1
	240V AC	NLT2ANR	222248	NLT2ANA	222249	NLT2ANG	222250	NLT2ANV	222251	NLT2ANL	222252	NLT2ANI	222253 1
<b>Flashing light units (bulb LED)</b> (bulb included)	24V AC/DC	NLT2BDLR	222289	NLT2BDLA	222290	NLT2BDLG	222291	NLT2BDLV	222292	NLT2BDLL	222293	NLT2BDLI	222294 1
	115V AC	NLT2AJLR	222295	NLT2AJLA	222296	NLT2AJLG	222297	NLT2AJLV	222298	NLT2AJLL	222299	NLT2AJLI	242464 1
	240V AC	NLT2ANLR	222301	NLT2ANLA	222302	NLT2ANLG	222303	NLT2ANLV	222304	NLT2ANLL	222305	NLT2ANLI	222306 1
<b>Strobe light units</b> (bulb included)	24V AC/DC	NLT3BDR	222254	NLT3BDA	222255	NLT3BDG	222256	NLT3BDV	222257	NLT3BDL	222258	NLT3BDI	222259 1
	115V AC	NLT3AJR	222260	NLT3AJA	222261	NLT3AJG	222262	NLT3AJV	222263	NLT3AJL	222264	NLT3AJI	222265 1
	240V AC	NLT3ANR	222266	NLT3ANA	222267	NLT3ANG	222268	NLT3ANV	222269	NLT3ANL	222270	NLT3ANI	222271 1

Signalling devices

Intro

A

B

C

D

E

F

G



H

I

J/X



Audio units

	Protection degree	Supply voltage	Cat. no.	Ref. no.	Pack
 <p>Pulsating tone</p>	IP54	24V AC/DC	NLT73BD	222278	1
	IP65	24V AC/DC	NLT77BD	222279	1
 <p>Pulsating or constant tone Adjustable by removing or inserting bridge JP1 in the printed circuit</p>	IP54	115V AC	NLT75AJ	222287	1
		240V AC	NLT75AN	222288	1
	IP65	115V AC	NLT77AJ	222280	1
		240V AC	NLT77AN	222281	1
 <p>Modulated tone 16 sounds can be selected by means of dip switch</p>	IP54	24V AC/DC	NLT75BD	222286	1

The audio units can only be mounted as final top unit (top cover included)

Bulbs

	Supply voltage	Red		Amber		Yellow		Green		Blue		White				
		Cat. no.	Ref. no.	Cat. no.	Ref. no.	Cat. no.	Ref. no.	Cat. no.	Ref. no.	Cat. no.	Ref. no.	Cat. no.	Ref. no.	Pack		
 <p>LED - BA15D</p>	24V AC/DC	BA15D24LR	222330	BA15D24LA	222331	BA15D24LG	222332	BA15D24LV	222333	BA15D24LL	222334	BA15D24LB	222335	1		
	115V AC	BA15D115LR	222336	BA15D115LA	222337	BA15D115LG	222338	BA15D115LV	222339	BA15D115LL	222340	BA15D115LB	222341	1		
	240V AC	BA15D230LR	222342	BA15D230LA	222343	BA15D230LG	222344	BA15D230LV	222345	BA15D230LL	222346	BA15D230LB	222347	1		
<p>Incandescent BA15D</p>		Clear														
														Cat. no.	Ref. no.	Pack
	12V													BA15D125	222348	5
	24V													BA15D245	222349	5
	30V													BA15D305	222350	5
	115V													BA15D1155	222351	5
240V													BA15D2305	222352	5	

Terminal

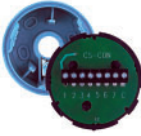
	Cat. no.	Ref. no.	Pack
 <p>Terminal unit with top cover</p>	NLT9TC	222282	1

Base with tube

	Cat. no.	Ref. no.	Pack
 <p>Base + tube height 100mm</p>	NLT5BT	222284	1
Base + tube height 100mm, 90° fixing	NLT90BT	222307	1
Tube height extension 100mm	NLT5ET	222285	1

Light towers

Intro

- A
- B
- C
- D
- E
- F
- G
- H
- I
- J/X



**Technical data**

Conformity to standards	EEC regulation 89/336 electromagnetic compatibility EEC regulation 73/23 low voltage, including amendment EEC 93/68 All NLT range are made and tested in full compliance with: EN 60947-5-14 (VDE 0470, IEC 60947) CE, cUL US
Materials	Polycarbonate Visual and audio signal units, terminal unit, top cover, base and extension tubes
Rated insulated voltage	250V max.
Operating temperature	-20°C ... +60°C (except version with bulb 12V = 40°C)
Protection degree (according to EN 60529)	IP65 (IP54 for audio units types NLT73xx and NLT75xx) (indicators must be correctly assembled with top cover, gasket or PG conduit fitting)
Colours (according to EN 60073)	Amber, Blue, Yellow, Clear, Red and Green
Lamp type	
Steady/flashing units	Bayonet type BA15D socket: filament (7W max.) or LED
Strobe units	Xenon lamps
Nr. of combined units	Up to 7 modular units
Connection	Captive screw cable connectors (max. cable size 1.5mm <sup>2</sup> ) inside terminal sleeve «C» is common to all signal units.
Connection identification code	They are numbered 1/7 from base to top

**Mechanical characteristics**

Mounting of the units	
Average torque	2.4Nm
Unfastening of the units	
Average torque	2.3Nm
Vibration resistance	2g min. (10-150Hz) according to IEC 68-2-6
Mounting	Direct through terminal unit or with base and tube

**Dimensions**

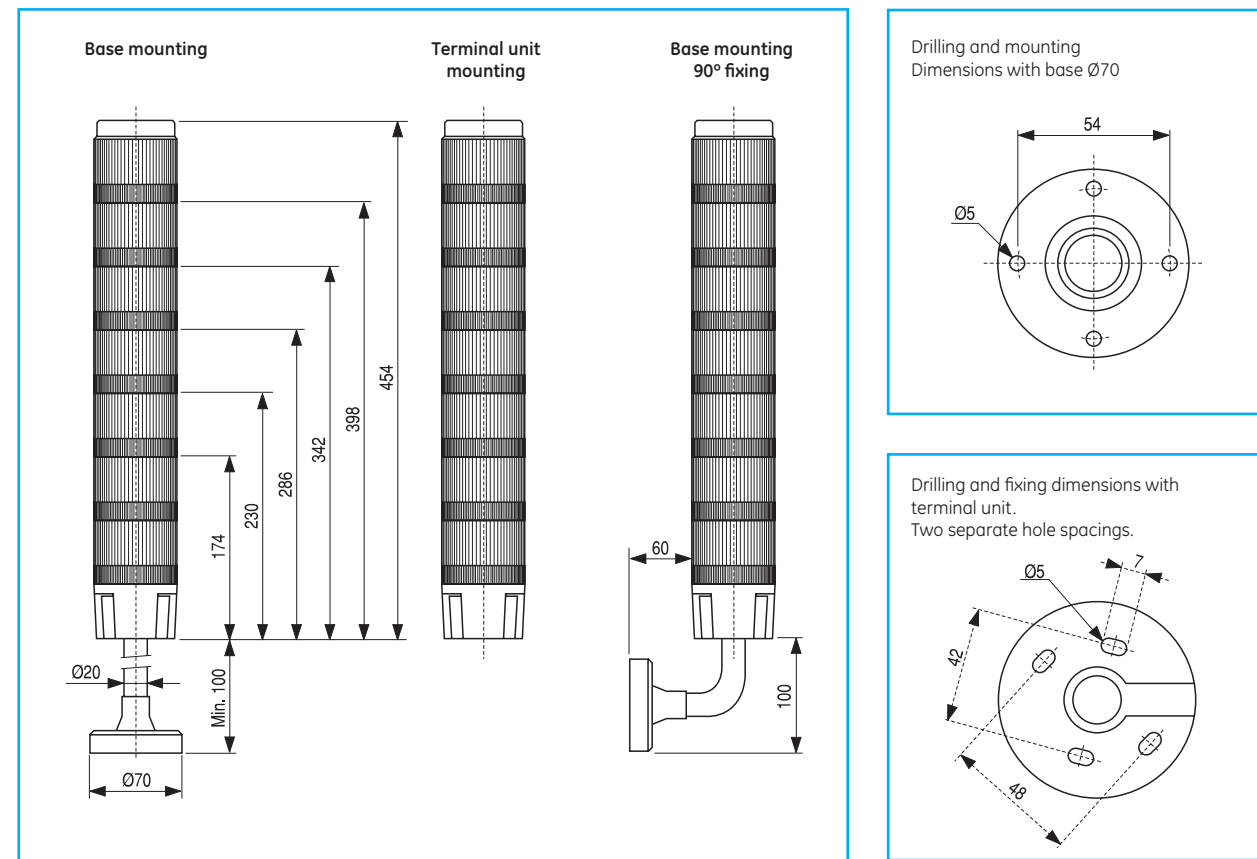



Modular system

Place signal beacon unit onto terminal unit **(1)** align guide marks and twist clockwise till they are locked **(2) + (3)**

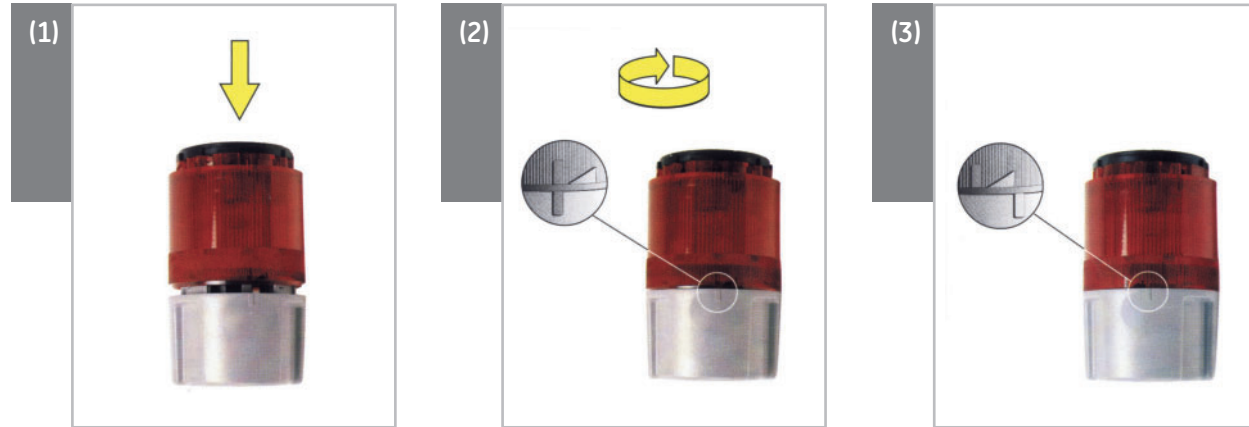

Follow the same steps to add more signal units **(4) + (5) + (6)**  
The audible element can be mounted as final top unit, as it is complete with a top cover.

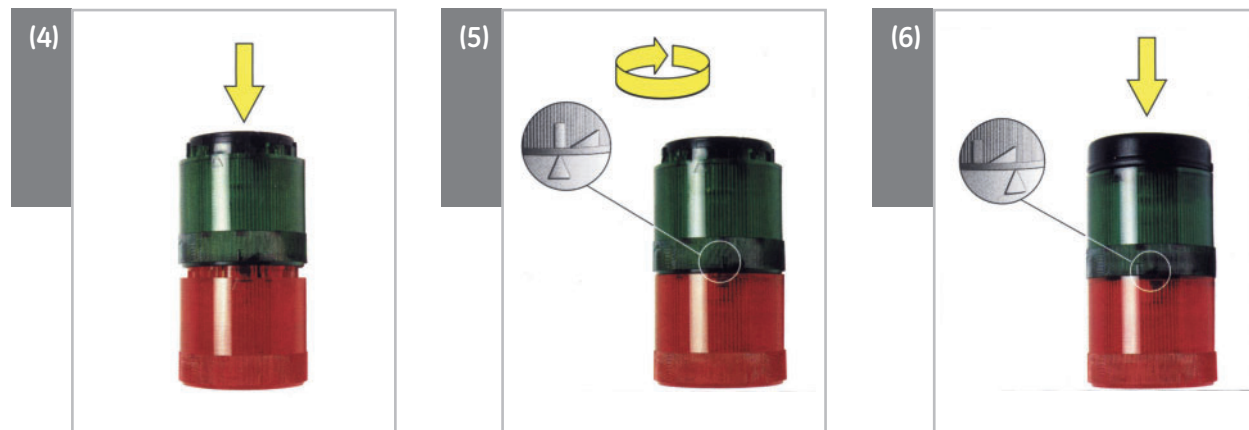

To fix extension tube (base always included), insert it into opening on the underside of the terminal unit and tighten screw on the side **(7)**. To reach the screw cable clamp terminals, remove black disc first, prising with a small screwdriver **(8)**. Connect to terminals (coloured units are numbered from base to top). To place terminal back into position, align the guiding marks **(9)** and press inwards.



Light towers

Intro

A

B

C

D

E

F

G

H

I

J/X





## Foot switches

### General

Foot switches, for intensive services suitable for controlling and monitoring of low voltage AC and DC electrical circuits.

### Climatic protections

The standard versions are suitable for use in the following climates:

- Temperate climate cat. 23/50 (DIN 50014)
- Wet climate cat. 23/83 (DIN 50015)
- Hot wet climate cat. 40/92 (DIN 50015)
- Variable wet climate cat. FW 24 (DIN 50016)

### Standards

IEC 947-5-1, CEI EN 60947.5.1  
VDE 0660

### Approvals

CSA, UL

### Specifications

Temperature ranges	Operation	from -30°C up to +80°C						
	Storage	from -30°C up to +80°C						
Degree of protection (according to IEC 529)		IP 65						
Vibration resistance		20g (10 up to 55Hz)						
Mechanical endurance		2 × 10 <sup>7</sup> for all the types						
<b>Electrical</b>								
Rated insulation voltage according to EN 60947.1		500V						
Insulation class according to VDE 0110		Group C						
Electric shock protection according to IEC 536		Class I						
Short-circuit prot. according to IEC 269.1 and 269.3		10A gL fuses						
<b>Electrical performances of the contact blocks</b>								
Rated thermal current (I <sub>th</sub> )		10A						
Performances according to EN 60947.5.1								
Slow motion contacts	Voltage	U <sub>e</sub> (V)	24	48	110	220	380	
	Category AC 15	Current	I <sub>e</sub> (A)	6	6	6	6	4
Snap action contacts	Voltage	U <sub>e</sub> (V)	24	48	110	220	380	
	Category AC 15	Current	I <sub>e</sub> (A)	6	6	6	5	4
Category DC 13	Voltage	U <sub>e</sub> (V)	24	48	110	220		
	Current	I <sub>e</sub> (A)	1	0,8	0,7	0,3		
Connection		Same polarity for both slow motion and snap action contacts						
Cables entries	IPA1, IPA2, IPB1, IPB2	1 × M20						
	IPA1-P	2 × M20						

Order codes ● pg. F.69  
Dimensional drawings ● pg. F.69

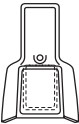

Foot switches - order codes

		Slow break				Snap action					
		11 23 NC NO 12 24	11 23 31 43 NC NO NC NO 12 24 32 44	13 21 NO NC	13 21 33 41 NO NC NO NC 14 22 34 42						
		Function (1)	Cat. no	Ref. no.	Cat. no	Ref. no.	Cat. no	Ref. no.	Cat. no	Ref. no.	Pack
	ONE pedal Without guard	N	IPA1-N211B	132170	-	-	IPA1-N411B	132198	IPA1-N422B	132213	1
	ONE pedal With guard	N	IPB1-N211B	132172	IPB1-N222B	132186	IPB1-N411B	132201	IPB1-N422B	132215	1
		D	-	-	-	-	-	-	IPB1-D422B	132216	1
		R	-	-	-	IPB1-R411B	132203	-	-	-	1
Spare microswitches			N211B	116113	N222B	116664	N411B	116663	N422B	116665	1

(1) **Function N**  
Normal operation. When the pedal is pressed the contacts change position. When released they return to their position.

**Function D**  
Two-stage operation. Used with two contacts blocks. When the pedal is pressed to the first point, the contacts of the first block switch; when pressed as far as the second point the contacts of the second block switch and the first block stays in the same position.

**Function R**  
Normal operation with potentiometer. When the pedal is pressed, the contacts change position at the same time as the potentiometer is operated. When released, the contacts and potentiometer return to their initial position.

 Positive opening.

Dimensional drawings

Foot switches without protective guard

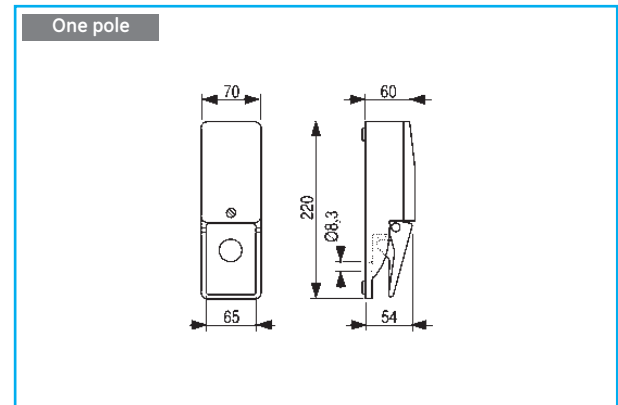

Foot switches with protective guard

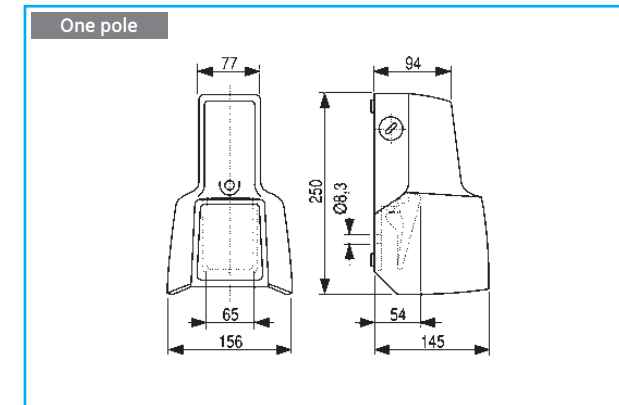

Foot switches

- Intro
- A
- B
- C
- D
- E
- F**
- G
- H
- I
- J/X





Approvals



Standards

EN 60947-1 / IEC 60947-5-1

Features

Enclosed in metal with aluminium protection cover, safety latch function "OFF-ON-OFF" with manual reset.

Technical data

Switching diagram	
Rated insulation voltage U <sub>i</sub>	max. 400VAC
Thermal continuous current I <sub>thc</sub>	max. 10A
Switching frequency	max. 50/min.
Mechanical operational life number of switching cycles	10 x 10 <sup>6</sup>
Ambient temperature	-30°C to +80°C
Cable conduits	(3x) M20x1.5
Protection degree	IP65
Actuating force (approx.)	10N
Trigger point	200N
Weight	1.5 kg

Safety foot switches

Operation

- 1 Pedal operation up to the trigger point**  
The operating contact is closed, the operating process is started
- 2 Operation past the trigger point in emergency cases**  
The operating contact is opened and latched and the process is stopped. Also if the device is unused, the latch remains in the off-position in this phase. Uncontrolled restart is prevented
- 3 Reset function**  
Only after the danger has passed can the contacts be manually unlatched (push-button on the side). The operating process can now be restarted by pushing the pedal up to the triggering point.

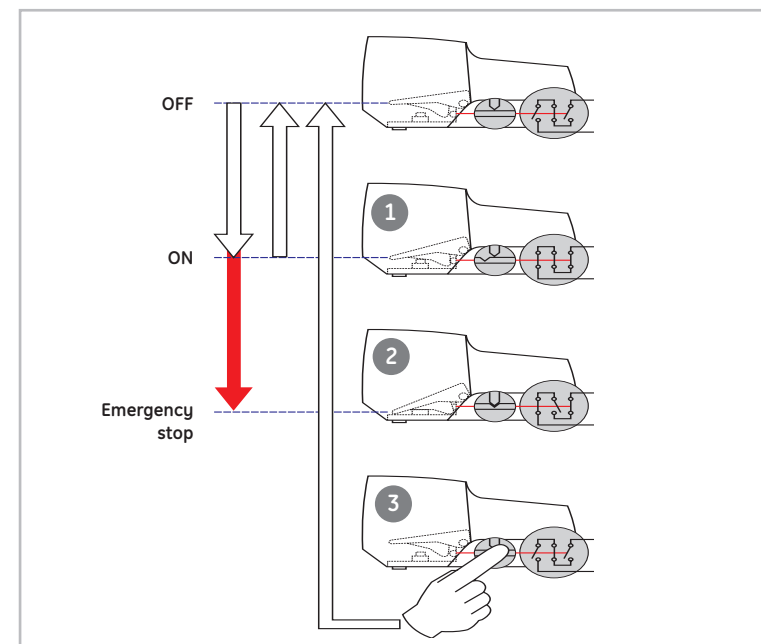

Order codes

	Cat. no.	Ref. no.	Pack
- Slow-action contact - Snap-action contact - Trigger point - Latch function - Making current according to: EN/IEC 60947-5-1 AC15/240V/3A	IPSF1	223000	1

Dimensional drawings

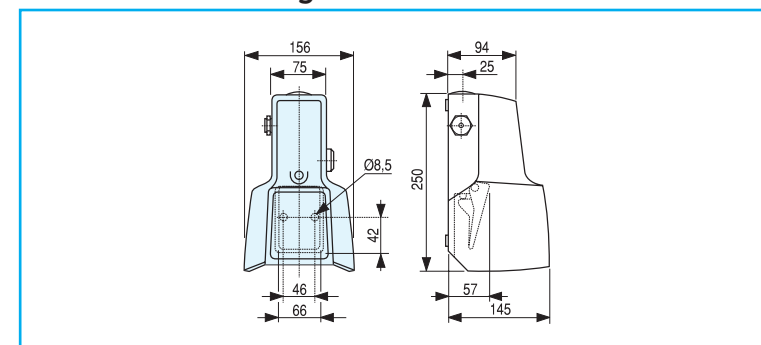



## Electronic relays

### Series NMV - Order codes

G.2 Multivoltage electronic timers - 22.5mm module

### Series D - Order codes

G.3 Single voltage electronic timers - 45mm module

G.3 Earth leakage relays

G.4 Protection relays

G.5 Liquid level detectors relay

G.5 Detection relays

G.5 Control and protection relays

### Technical data

G.6 Series NMV

G.10 Series D

## POWER DEVICES

Contactors and overload relays

### Dimensions

G.20 Series NMV and D

Auxiliary relays and contactors

### Limit switches

G.22 **Series IS and IM** - Metal and thermoplastic limit switches

Motor protection devices

G.24 **Series IUG** - Thermoplastic limit switches

G.26 **Series IZ** - Miniature thermoplastic limit switches

Applications

**G.27 Series IP** - Stainless steel limit switches - Heavy duty - IP40

Main switches

G.28 **Series 114FCT** - Three pole limit switches

G.30 Technical data

G.31 Dimensions

## AUXILIARY DEVICES

Control and signalling units

**G.36 Series 115** - Pressure switches

## Electronic relays and limit switches

## POWER ELECTRONICS

Speed drive units

Soft starters

Lighting dimmer-stabilizer/Numerical index

Intro

A

B

C

D

E

F

G

H

I

J/X



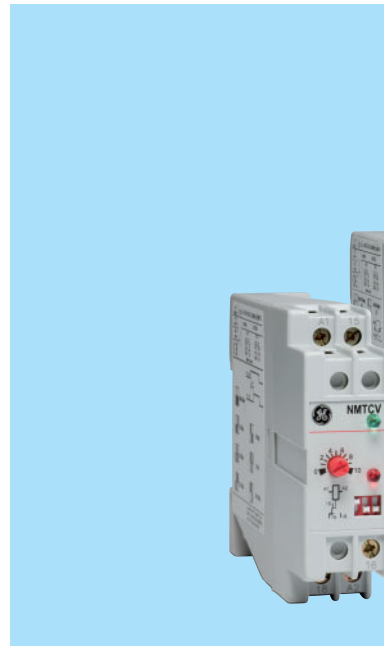





**Series NMV Multivoltage timers  
22.5mm module**

- Timers: 22,5mm multivoltage 24-240V AC/DC relay
- Functions: delayed ON, OFF, star-delta, intermittence and multifunction
- 2 LED indication:  
Green flashing during timer function and stable after relay energized.  
Red when output contact is ON

**Standards**

VDE 0106	CSA C 22.2 Nr.14	UNE 20-119
VDE 0110	UL 94	IEC/EN 60947-5-1
EN 50002	UL 508	IEC/EN 61812-1
EN 50042	IEC 255.5	CE
		cUL

**Multivoltage electronic timers - 22.5mm module**

		Supply voltage	Time range	Available contacts	Cat. no.	Ref. no.	Pack.
	<b>Delayed ON relay</b>	Direct	0.06 sec - 100 h	2 changeover	NMTCV 2	124901	1
		24-240V AC/DC	Technical data: see G.6				
	<b>Star-delta starter relay</b>	Direct	1 - 10 sec.	1 changeover	NMETV	124908	1
		24-240V AC/DC	6 - 60 sec.	1 changeover	NMETV t AU <sup>(1)</sup>	124911	1
	<b>Delayed OFF timer</b>	Direct	0.5 - 6 sec.	2 changeover	NMRDV 2-6	124915	1
		24-240V AC/DC	5 - 60 sec.	2 changeover	NMRDV 2-60	124916	1
	<b>Asymmetric intermittence, started by connection or pause (choice)</b>	Direct	0.06 sec - 100 h	1 changeover	NMIVV	124929	1
		24-240V AC/DC	Technical data: see G.8				
	<b>Multifunction</b>	- Delayed ON timer		- Impulse ON timer			
		- Delayed ON through contact timer		- Impulse ON through contact timer			
		- Delayed OFF through contact timer		- Impulse OFF through contact timer			
		- Delayed ON and OFF through contact timer		- Impulse ON and OFF through contact timer			
		<b>Module 22,5mm</b>					
		Direct	0.6 sec - 100 h	1 changeover	NMMFV	124930	1
		24-240V AC/DC	Technical data: see G.9				

Dimensions ● pg. G.20

(1) AU = coil 380V 50/60 Hz  
(2) Transformer inside the timer housing



**Series D Single voltage relays 45mm module**

- Line protection and detection relays.
- Detection functions: motor re-start, thermistor, earth-leakage, voltage, current, frequency ...
- Line protection: unbalance, maximum and minimum voltage, phase sequence ...



**Standards**



VDE 0106	CSA C 22.2 Nr.14	UNE 20-119
VDE 0110	UL 94	IEC/EN 60947-5-1
EN 50002	UL 508	IEC/EN 61812-1
EN 50042	IEC 255.5	CE
		cUL

Single voltage relays

**Single voltage electronic relays - 45mm module**

	Supply voltage	Voltage	Available contacts	Time range	Cat. no.	Ref. no.	Pack
<b>Motor re-start control relay (plug in)</b> 	Direct <sup>(1)</sup>	220-230V 50/60Hz	RCRT 1 changeover	0.2 - 6 sec. (memory time)	RCRT 6 - 60AN	123624	1
		110-125V 50/60Hz		0.2 - 60 sec. (delayed time)	RCRT 6 - 60AJ	123623	1
	11 pins socket for RCRT for panel fixing. Front terminals Technical data: see G.10					PRCZ11	220647

**Earth leakage relays - 45 mm module**

	Voltage (V)	Contacts	Sensiv. (A)	Ø (mm)	Differential transformers			Earth leakage relays		
					Cat. no.	Ref. no.	Pack	Cat. no.	Ref. no.	Pack
<b>Differential earth leakage relay with hand reset (with test)</b> 	220-230V 50/60Hz	RDHT 1-... With test 1 changeover	0.2 - 1.2	35	WKAT 35-1,2A/2V	204165	1	RDHT 1-1,2AEN	123744	1
				70	WKAT 70-1,2A/2V	204166	1			
	220-230V 50/60Hz	1 - 10	35	WKAT 35-10A/2V	204169	1	RDHT 1-10AEN	123754	1	
				70	WKAT 70-10A/2V	204170				1
Technical data: see G.12										
<b>Differential earth leakage relay with automatic reset (with test)</b> 	380-400V 50/60Hz	RDHA 1-... With test 1 changeover	0.2 - 1.2	35	WKAT 35-1,2A/2V	204165	1	RDHA 1-1,2AEU	123965	1
				70	WKAT 70-1,2A/2V	204166	1			
	220-230V 50/60Hz	1 - 10	35	WKAT 35-10A/2V	204169	1	RDHA 1-10AEN	123964	1	
				70	WKAT 70-10A/2V	204170				1
Technical data: see G.12										

(1) Possibility of fitting a remote potentiometer.  
(2) Transformer inside the relay

Intro

A

B

C

D

E

F

G

H

I

J/X



Liquid level detector relay

	Voltage (V)	Contacts	No. of circuits	Cat. no.	Ref. no.	Pack
	220-230V 50/60Hz	DINIL ...E 1 changeover	2	DINIL 02E ENU	123656	1
	11 pins socket for DINIL-02E, -03E. for panel fixing. Front terminals Technical data: G.11			PRC211	220647	1
Probes	Without cable. Waterproof and protected with a thermoplastic housing. Stainless steel probe.			SON-3	123700	1



Detection relays

	Supply voltage	Contacts	Operating range	Voltage drop	Input impedance	Max. input voltage	Cat. no.	Ref. no.	Pack
Voltage detector relay	Direct and with transformer	RDT 2-... 2 changeover	40 - 400V	-	800 kΩ	600V	RDT2400VEN <sup>(1)</sup>	124184	1
Current detector with delay (0.5 - 15 sec.)	Direct and with transformer	RDIT 2-... 2 changeover	0.5 - 5A	0.25V	0.05Ω	10A	RDIT2-5AEN <sup>(1)</sup>	124754	1
			20 - 200mV	1 kΩ	15V	RDIT2-02VEN <sup>(1)</sup>	124354	1	



Control and protection relays

	Supply voltage	Contacts	Thermal probe <sup>(5)</sup> When cold - When hot		Jumper terminals	Setting range	Cat. no.	Ref. no.	Pack
Thermistor relay	Direct and with transformer <sup>(4)</sup>	RS01N 1 changeover	1.5 kΩ	2.5 kΩ			RS01NEN <sup>(3)</sup>	212759	1
							RS01NAJ <sup>(2)</sup>	124373	1
Frequency control relay	With transformer <sup>(4)</sup>	RCF 1-... 1 changeover			Without	5 - 15Hz	RCF-1 AJ <sup>(2)</sup>	124433	1
					Y1 - Y2	15 - 45Hz	RCF-1 EN <sup>(1)</sup>	124434	1
					Y1 - Y3	45 - 135Hz	RCF-1 AU <sup>(3)</sup>	124435	1



(1) EN = coil 220/230V 50/60Hz  
 (2) AJ = coil 110V 50/60Hz  
 (3) AU = coil 380/400V 50/60Hz







(4) Transformer inside the timer housing  
 (5) Thermal probe resistance not included  
 (6) ENU = coil 220-230V 380-400V 50/60Hz

Dimensions ● pg. G.20





Protection relays

	Supply voltage contact	Contacts	Operating range		Unbalance	Mains frequency	Cat. no.	Ref. no.	Pack
			Umin.	Umax.					
 <p><b>Integral protection relay for three-phase lines</b></p>	400V 50Hz With transformer <sup>(1)</sup>	RDFF 1-... 1 changeover	5 - 20%	5 - 15%	2.5 - 10%	50 Hz	RDFF1-50AU	123985	1
	Technical data: see G.13								
 <p><b>Unbalance and phase failure protection relay for three-phase lines</b></p>	400V 50Hz Direct and with transformer <sup>(1)</sup>	RPDF 2-... 2 changeover	-	-	2.5 - 10%	50 Hz	RPDF2-50AU	124025	1
	Technical data: see G.14								
 <p><b>Phase sequence and phase failure protection relay for three-phase lines</b></p>	400V 50Hz With transformer <sup>(1)</sup>	RSFF 1-... 1 changeover	-	-	-	50 Hz	RSFF1-50AU	124622	1
	Technical data: see G.15								
 <p><b>Phase sequence protection relay for three-phase lines</b></p>	220-230V 380-400V 50/60Hz With transformer <sup>(1)</sup>	RSF 1-... 1 changeover	-	-	-	50 Hz	RSF1-50ENU <sup>(6)</sup>	124051	1
	Technical data: see G.15								
 <p><b>Maximum and minimum voltage protection relay for three-phase lines</b></p>	380/400V 220/230V 50/60Hz With transformer <sup>(1)</sup>	RTMM 2-... 2 changeover	5 - 20%	5 - 15%	-		RTMM 2 AU RTMM 2 EN	124085 124084	1 1
	Technical data: see G.16								
 <p><b>Maximum and minimum voltage protection relay for a single-phase lines</b></p>	220/230V 50/60Hz With transformer <sup>(1)</sup>	RMM 2-... 2 changeover	5 - 20%	5 - 15%	-		RMM 2 EN	124104	1
	Technical data: see G.16								

(1) Transformer inside the relay

Electronic relays of 45 mm

Intro

A

B

C

D

E

F

G

H

I

J/X



## NMTCV2 Delayed ON timer

### Function

Electronic relay whose output contact connects with a certain adjustable delay from the moment voltage is applied to supply terminals **A1-A2**.

It has seven timing ranges : see drawing. ↗

Range selection is made by dipperswitches located on the front of the relay. Times are set by front potentiometer controlling an Application Specific Integrated Circuit (ASIC) specially designed for this group of relays. This allows for excellent precision and repeatability features.

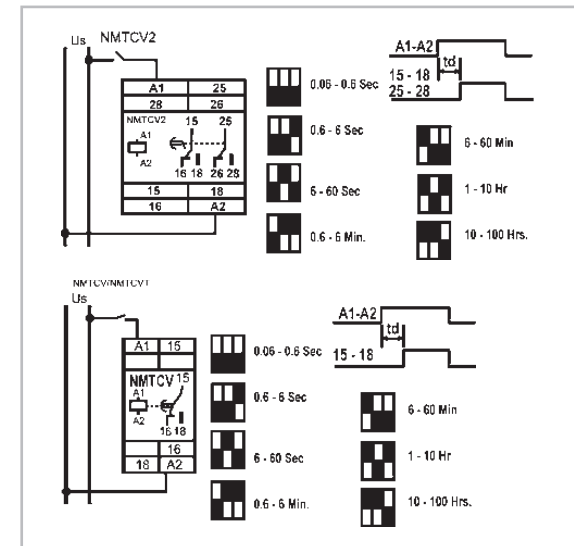

↗ 0.06 - 0.6s, 0.6 - 6s, 6 - 60s, 0.6 - 6 min, 6 - 60 min, 1 - 10h, 10 - 100h

### Technical characteristics

		NMTCV2	
Nr. of changeover contacts		2	
Output contacts:			
Rated insulation voltage $U_i$	AC (V)	250	
	DC (V)	250	
Thermal current $I_{th}$	(A)	6	
Utilisation AC-15			
Rated voltage $U_e$	(V)	120/230	
Rated current $I_e$	(A)	2.5/1.3	
Utilisation DC-13			
Rated voltage $U_e$	(V)	110/230	
Rated current $I_e$	(A)	0.2/0.1	
Supply voltages (Un)			
AC/DC (direct)	(V)	24-240	
AC(with transformer)	(V)	-	
Frequency	(Hz)	50/60	
Supply voltage tolerance	(%)	+10 / -20	
Consumption	(mA)	60 (24V)	
	(mA) (240V)	15	
	(VA)	-	
Input circuit test voltage (between input, output and group circuits)	(kV)	4	
Switch ON response time		0.06s - 100 h.	
Switch OFF response time	(ms)	150	
Reset time between 2 cycles <sup>(1)</sup>	(ms)	100	
Repeat accuracy with 0.85 - 1.1 Un	(%)	1	

### Ambient conditions

Storage temperature	-40°C to +80°C
Operating temperature	-25°C to +60°C
Relative humidity	95% (without condensation)
Max. operating altitude	2.000 m
Degree of protection	IP40; terminals IP20
Operating positions	Any position

### Conformity to standards

VDE 0106	CSA C 22.2 No 14
VDE 0110	IEC/EN 60255-5
EN 50002	UL 94
EN 50042	UL 508
IEC/EN 60947-5-1	UNE 20-119
CE	

(1) Reset time: Time that must go by from the relay ends an operation until it is able to initiate the next one without error.

#### Remark

The relay has a green LED that lights when the relay is energised ( flashing during the timing ) and a red LED that lights when output contact is made.

## NMETV... Star-delta starter timer

### Function

Electronic relay timed in steps whose purpose is to control star-delta starting. When supply voltage is applied to the **A1-A2** terminals, the star contact (17-18) closes for an adjustable time between up to 100 h (selectable). When this time is up, it opens, there is a pause and then the delta contact connects (17-18). The standard pause time is about 100ms. Times are set by front potentiometer controlling an ASIC specially designed for this group of relays. This allows for excellent precision and repeatability features.

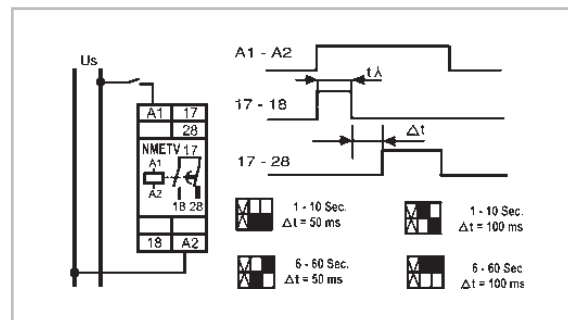

### Technical characteristics

	NMETV	NMETV t
Nr. of changeover contacts	2	
Output contacts:		
Rated insulation voltage Ui	AC (V)	250
	DC (V)	250
Thermal current Ith	(A)	6
Utilisation AC-15		
Rated voltage Ue	(V)	125/230
Rated current Ie	(A)	2.5/1.3
Utilisation DC-13		
Rated voltage Ue	(V)	110/230
Rated current Ie	(A)	0.2/0.1
Supply voltages (Un)		
AC/DC (direct)	(V)	24-240
AC(with transformer)	(V)	-
		110-125 200-240 380-440
Frequency	(Hz)	50/60
Supply voltage tolerance	(%)	+10 / -20
Consumption	(mA)	50 (at 24V)
	(mA)	12 (at 240V)
	(VA)	-
	(VA)	3.5
Test voltage (between input, output and ground)	(kV)	4
Switch ON response time	(ms)	100
Reset time between 2 cycles <sup>(1)</sup>	(ms)	100
Repeat accuracy with 0.85 - 1.1 Un(%)		2

### Ambient conditions

Storage temperature	-40°C to +80°C
Operating temperature	-25°C to +60°C
Relative humidity	95% (without condensation)
Max. operating altitude	2.000 m
Degree of protection	IP40; terminals IP20
Operating positions	Any position

### Conformity to standards

VDE 0106	CSA C 22.2 No 14
VDE 0110	IEC/EN 60255-5
EN 50001 (NMETV)	UL 94
EN 50002	UL 508
EN 50042 (NMRDV)	UNE 20-119 (NMRDV)
IEC/EN 60947-5-1 (NMRDV)	CE

- (1) Reset time: Time that must go by from the relay ends an operation until it is able to initiate the next one without error.  
 (2) For 24V c.c. = 300ms

**Remark**  
 NMETV relays have a green LED that lights up when the relays is energised ( flashing during the timing) and a red LED that lights up when the star contact 17-18 is closed.

## NMRDV... Delayed OFF timer

### Function

Electronic relay whose output contact instantly connects when supply voltage is applied to terminals **A1-A2**. It disconnects with an adjustable delay as from the moment the relay loses supply voltage. There are several types depending on the range of timers.

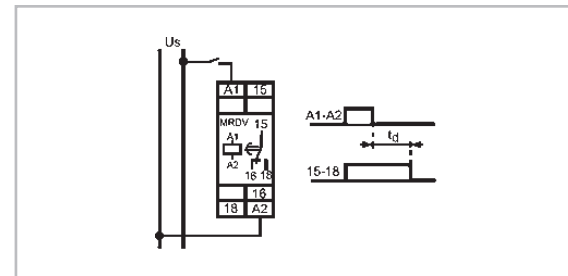

### Technical characteristics

	NMRDV2	
Nr. of changeover contacts	2	
Output contacts:		
Rated insulation voltage Ui	AC (V)	250
	DC (V)	250
Thermal current Ith	(A)	6
Utilisation AC-15		
Rated voltage Ue	(V)	125/230
Rated current Ie	(A)	2.5/1.3
Utilisation DC-13		
Rated voltage Ue	(V)	110/230
Rated current Ie	(A)	0.2/0.1
Supply voltages (Un)		
AC/DC (direct)	(V)	24-240
AC(with transformer)	(V)	-
		200-240 380-440
Frequency	(Hz)	50/60
Supply voltage tolerance	(%)	+10 / -20
Consumption	(mA)	1.5 (at 24V)
	(mA)	5 (at 240V)
	(VA)	-
	(VA)	-
Test voltage (between input, output and ground)	(kV)	4
Switch ON response time	(ms)	250 <sup>(2)</sup>
Switch OFF response time	(ms)	0.5 - 600
Reset time between 2 cycles <sup>(1)</sup>	(ms)	250
Repeat accuracy with 0.85 - 1.1 Un(%)		5

Electronic relays of 22.5 mm

Intro

A

B

C

D

E

F

G

H

I

J/X



**NMIVV Asymmetric intermittence, started by connection or pause (choice)**

**Function**

Electronic relay whose output contact connects and disconnects intermittently. Connection and pause times may be separately. The intermittency cycle begins a connection or disconnection selected by a dip-switches and start the instant connection is made from supply voltage to the **A1-A2** terminals. A new step is begun if voltage supply is interrupted during operation.

It has seven timing ranges ;

NMIVV : 0,6 sec - 100 h

Range selection is made by dip-switches located on the front of the relay. Times are set by front potentiometer an ASIC specially designed for this group of relays. This allows for excellent precision and repeatability features.

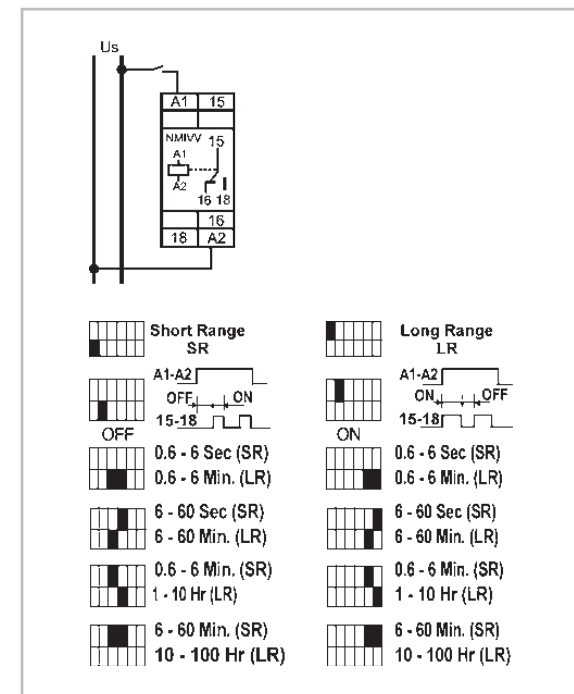

**Technical characteristics**

		NMIVV
Nr. of changeover contacts		1
Output contacts:		
Rated insulation voltage Ui	AC (V)	250
	DC (V)	50
Thermal current Ith	(A)	6
Utilisation AC-15		
Rated voltage Ue	(V)	125/230
Rated current Ie	(A)	2,5/1,3
Utilisation DC-13		
Rated voltage Ue	(V)	110/230
Rated current Ie	(A)	0,2/0,1
Supply voltages (Un)		
AC/DC (direct)	(V)	24-240
Frequency	(Hz)	50/60
Supply voltage tolerance	(%)	+10 / -20
Consumption	(mA)	60 (at 24V)
	(mA)	15 (at 240V)
	(VA)	-
Test voltage (between input, output and ground circuits)	(kV)	2
Switch ON response time	(ms)	150
Intermittent switch ON times <sup>(2)</sup>		0,6 s - 100 h.
Reset time between 2 cycles <sup>(1)</sup>	(ms)	150
Repeat accuracy with 0.85 - 1.1 Un(%)		1

**Ambient conditions**

Storage temperature	-40°C to +80°C
Operating temperature	-25°C to +60°C
Relative humidity	95% (without condensation)
Max. operating altitude	2.000 m
Degree of protection	IP40; terminals IP20
Operating positions	Any position

**Conformity to standards**

VDE 0106	CSA C 22.2 No 14
VDE 0110	IEC/EN 60255-5
EN 50002	UL 94
EN 50005	UL 508
EN 50042	UNE 20-119
IEC/EN 60947-5-1	CE

- (1) Reset time: Time that must go by from the relay ends an operation until it is able to initiate the next one without error.
- (2) Connection and pause times be set within different ranges.

**Remark**

These relays has a green LED that lights up when the relays is energised (flashing during the timing) and a red LED that lights up when output contact is made.



## NMMFV Multifunction relay

### Function

The functions of this multifunction and multirange electronic relay are selected by 3 dip-switches located on the front of the relay. It has eight functions: delayed ON timer, delayed ON through contact timer, delayed OFF through contact timer, delayed ON and OFF through contact timer, impulse ON timer, impulse ON through contact timer, impulse OFF through contact timer, impulse ON and OFF through contact timer. If the relay loses current during timing, it disconnects and is ready for a new cycle. It has seven timing ranges: see drawing. Range selection is made by dip-switches located on front of the relay. Times are set by front potentiometer controlling an ASIC specially designed for this group of relays. This allows for excellent precision and repeatability features.

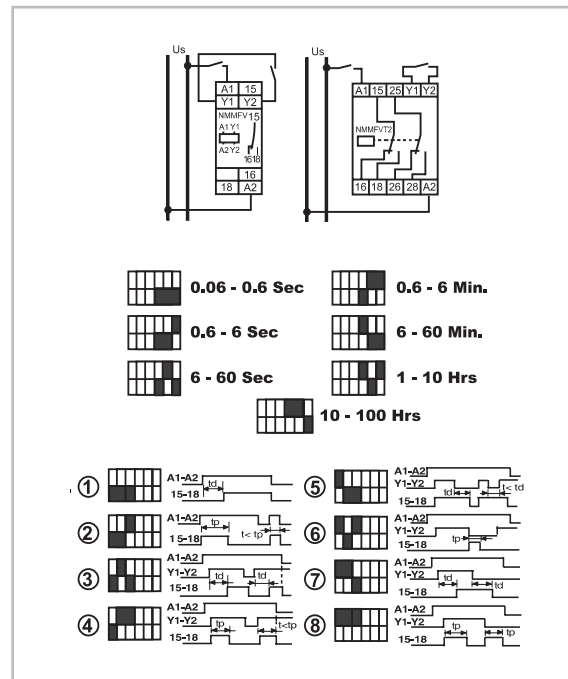

### Technical characteristics

		NMMFV
Nr. of changeover contacts		1
Output contacts:		
Rated insulation voltage $U_i$	AC (V)	250
	DC (V)	250
Thermal current $I_{th}$	(A)	6
Utilisation AC-15		
Rated voltage $U_e$	(V)	110/230
Rated current $I_e$	(A)	2.5/1.3
Utilisation DC-13		
Rated voltage $U_e$	(V)	110/230
Rated current $I_e$	(A)	0.2/0.1
Supply voltages (Un)		
AC/DC (direct)	(V)	24-240
Frequency	(Hz)	50/60
Supply voltage tolerance	(%)	+10 / -20
Consumption	(mA)	60 (at 24V)
	(mA)	15 (at 240V)
	(VA)	-
Test voltage	(kV)	2
(between input, output and ground circuit)		
Switch ON response time		0.065 s - 100 h.
Switch OFF response time		0.065 s - 100 h.
Reset time between 2 cycles <sup>(1)</sup>	(ms)	150
Repeat accuracy with 0.85 - 1.1 Un(%)		1
Voltage open Y1-Y2	(V DC)	5
control contact terminals		
Current through control contact		
Initial	(mA)	15
Permanent	(mA)	1

Electronic relays of 22.5 mm

Intro

A

B

C

D

E

F

G

H

I

J/X

### Ambient conditions

Storage temperature	-40°C to +80°C
Operating temperature	-25°C to +60°C
Relative humidity	95% (without condensation)
Max. operating altitude	2,000 m
Degree of protection	IP40; terminals IP20
Operating positions	Any position

### Conformity to standards

VDE 0106	CSA C 22.2 No 14
VDE 0110	IEC/EN 60255-5
EN 50002	UL 94
EN 50042	UL 508
IEC/EN 60947-5-1	UNE 20-119
CE	

(1) Reset time: Time that must go by from the relay ends an operation until it is able to initiate the next one without error.

#### Remark

The relays have a green LED that lights up when the relays is energised (flashing during the timing) and a red LED that lights up when output contact is made.



**RCRT... Motor re-start control relay**  
(plug-in)

**Function**

RCRT...  
Correlation table between relay and 11pins socket.

RCRT	Socket
A1	8
A2	2
15	5
16	11
18	6

RCRT...  
The relay is used for instantaneous or delayed motor startup after a short-time power failure (max. 6 sec). The start occurs immediately if power supply is disrupted for less than 0.2 sec. If the power failure lasts longer, the relay activates its memory for a time that can be set to 0.2 to 6 sec, after which no automatic restart is possible. If power supply is restored while the memory period is elapsing, the relay commands a motor restart with a delay time from power supply restoration that can be set to 0.2 to 60 sec. A system stop cancels the memory function after 50 ms, and therefore the stop signal should be on for at least this time. The relay is non-sensitive to any control voltage fluctuation or disruption during or after the motor stop.

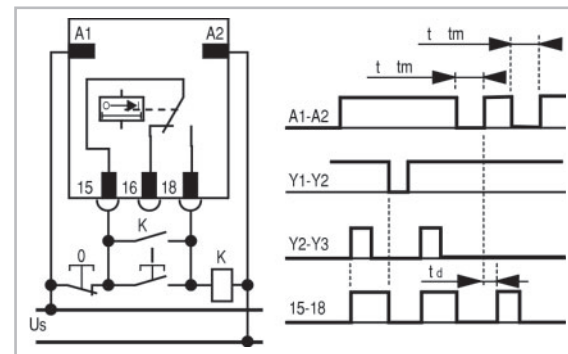

**Technical characteristics**

		RCRT 6-60
Nr. of changeover contacts		1
Output contacts:		
Rated insulation voltage $U_i$	AC (V)	400
	DC (V)	250
Thermal current $I_{th}$	(A)	6
Utilisation AC-15		
Rated voltage $U_e$	(V)	120/240
Rated current $I_e$	(A)	2.5/1.3
Utilisation DC-13		
Rated voltage $U_e$	(V)	110/220
Rated current $I_e$	(A)	0.2/0.1
Supply voltages ( $U_n$ )		
AC	(V)	110, 220-230, 125
Frequency	(Hz)	50/60
Permissible supply voltage variation (%)		+10 / -15
Repeat accuracy with 0.85 - 1.1 $U_n$ (%)		2
Consumption	(VA)	3
Input circuit test voltage (between input, output circuit and earth)	(kV)	4
Switch ON response time	(ms)	100
Power failure detection level		0.8 $U_s$
Reset time (stop)	(ms)	50 - 75
Memory reset time	(ms)	100
Max. restart delay time	(s)	0.2 - 60
Max. memory time	(s)	0.2 - 6

**Ambient conditions**

Storage temperature	-10°C to +85°C
Operating temperature	-5°C to +50°C
Relative humidity	95% (without condensation)
Max. operating altitude	2.000 m
Degree of protection	IP40; terminals IP20
Operating positions	Any position

**Conformity to standards**

VDE 0106	IEC/EN 60947-5-1
EN 50001	UNE 20-119
EN 50005	CE
EN 50011	
DIN 46199	

**Remark**

The relay has one LED that lights up when the contact is made.



## DINIL 02E Liquid level detector relay for simultaneous control of well and tank

### Functions

Plug-in devices for control of level of conductive liquids which can perform the following functions:

**Filling control:** The contact between 1 and 3 closes when the tank to be cheked drops below a minimum, fixed by the position of probe 6, which starts up the pumping system. When the maximum filling level is reached, fixed by the position of probe 7, the contact between 1 and 3, opens and the pumping system stops. For the filling control the two well probes must be connected externally to the common one (condition of full well).

**Draining control:** The contact 1-3 closes if the level liquid goes above a maximum, fixed by the position of probe 9, which starts up the drain pumping system. When the level drops below a minimum, fixed by the position of probe 8 the contact 1-3 opens and stop the pumping system, which prevents the pumpo from losing its prime.

**Simultaneous filling and draining control:** The system starts up whenever the tank requires liquid and the well has sufficient level to supply it, and it stops when the liquid reaches its maximum level in the tank or, as the case may be, the well reaches its minimum level.

**Remark:** In all the above applications, the contact between 1-3 is used as a permanent contact for starting and stopping the pump starter, whether this is DOL, star-delta or any other type of starter.

**Control voltage:** Two voltages:  
terminals 2-10 (220 VAC)  
terminals 2-11 (380 VAC)

### Technical characteristics

		DINIL-02E
Nr. of changeover contacts		1
Output contacts:		
Rated insulation voltage $U_i$	AC (V)	400
	DC (V)	250
Thermal current $I_{th}$	(A)	6
Utilisation AC-15		
Rated voltage $U_e$	(V)	120/240
Rated current $I_e$	(A)	2.5/1.3
Utilisation DC-13		
Rated voltage $U_e$	(V)	110/220
Rated current $I_e$	(A)	0.2/0.1
Supply voltages ( $U_n$ )		
AC (with transformer)	(V)	380-400/220-230 (two voltages)
Frequency	(Hz)	50/60
Permissible supply voltage variation(%)		+10 / -15
Repeat accuracy with 0.85-1.1 $U_n$ (%)		2
Consumption	(VA)	3
Input circuit test voltage (between input, output circuit and earth)	(kV)	4
Voltage between probes and common (V ef.)		6 - 18
Max. consumption of probes (mA ef.)		0.18
Max.resistance between probes (resistance of controlled liquid)	(kOhms)	200
Switch ON response time	(s)	1
Switch OFF response time	(s)	1

DINIL-02E - Filling control

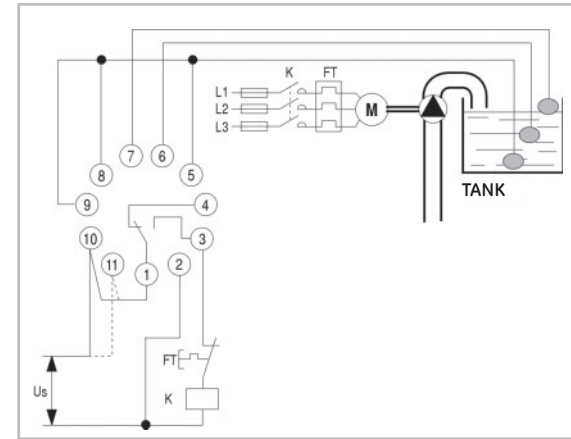

DINIL-02E - Draining control

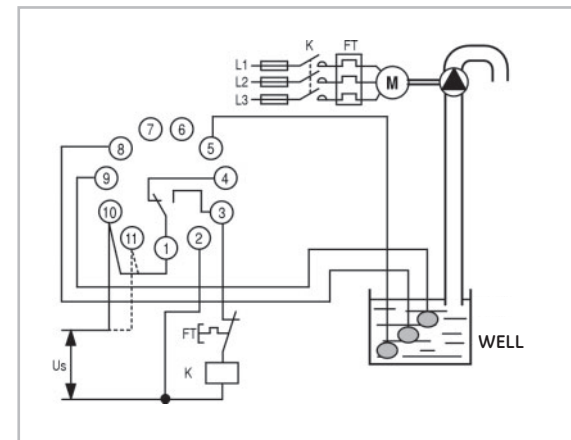

DINIL-02E - Simultaneous filling and draining control

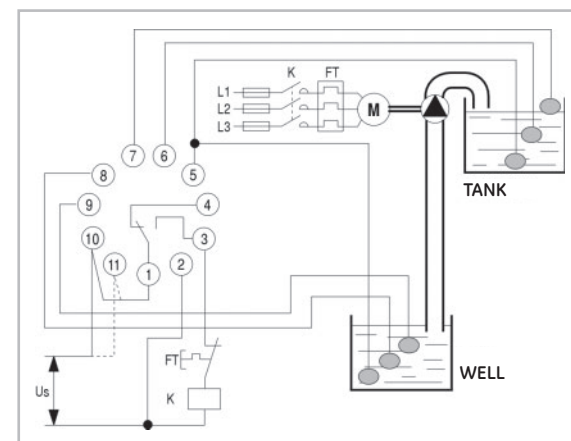

### Ambient conditions

Storage temperature	-10°C to +85°C
Operating temperature	-5°C to +50°C
Relative humidity	95% (without condensation)
Maximum operating altitude	2.000 m
Degree of protection	IP40; terminals IP20
Operating positions	Any

### Conformity to standards

VDE 0106 IEC/EN 60947-5-1 CE UNE 20119

#### Remark

The relays has one LED that lights up when the output contact is made.

Electronic relays of 45 mm

Intro

A

B

C

D

E

F

G

H

I

J/X



**RDHT... RDHA...**  
**Earth leakage relays**

**RDHT...** Earth leakage relay with manual reset, with test  
**RDHA...** Earth leakage relay with automatic reset, with test

**Function**

RDH, RDHT and RDHA are earth leakage detectors for industrial networks with neutral connected to earth, used with WKA (without test) and WKAT (with test) differential transformers. Tripping is produced when leakage current exceeds a threshold which is adjustable by means of a front mounted potentiometer. Tripping ranges are shown in the table below.

RDH and RDHT keep memory of tripping even in the absence of voltage in **A1** and **A2** and resetting is obtained from a push-button. RDHA is self resetting in the absence of control voltage in **A1** and **A2** or when leakage disappears. RDHT and RDHA have in addition a test push-button for control from cubicle door, and therefore those relays should always be use with WKAT transformers with test winding. All types have included a timer, with external adjustment in RDHA and internal ajustement in RDH and RDHT that allows to delay the trip to achieve trip selectivity.

RDHT1-... RDHA1-...	Sensitivity	Transformers	Ø
... 1,2	0.2 - 1.2A	WKAT-35 1.2A/2V	35
		WKAT-70 1.2A/2V	70
... 10	1 - 10A	WKAT-35 10A/2V	35
		WKAT-70 10A/2V	70

**Ambient conditions**

Storage temperature	-10°C to +85°C
Operating temperature	0°C to +50°C
Relative humidity	95% (without condensation)
Altitude	2.000 m
Degree of protection	IP40; terminals IP20
Operating positions	Any

**Conformity to standards**

VDE 0106	IEC/EN 60947-5-1
EN 50001	UNE 20-119
EN 50005	CE
EN 50011	
DIN 46199	

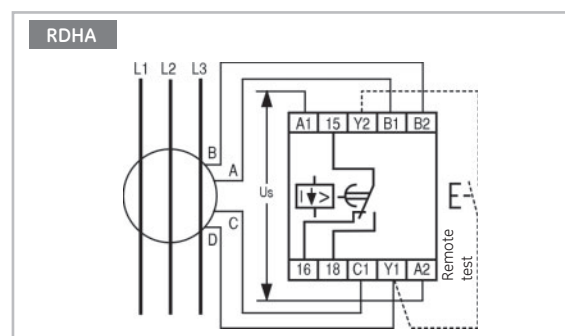
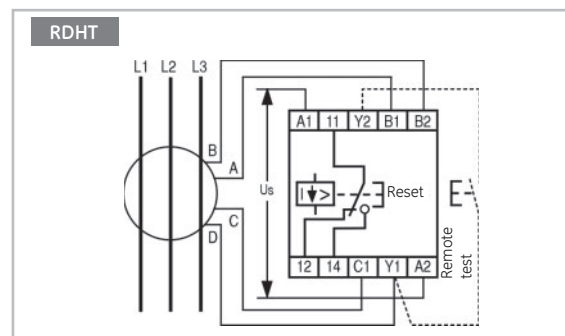
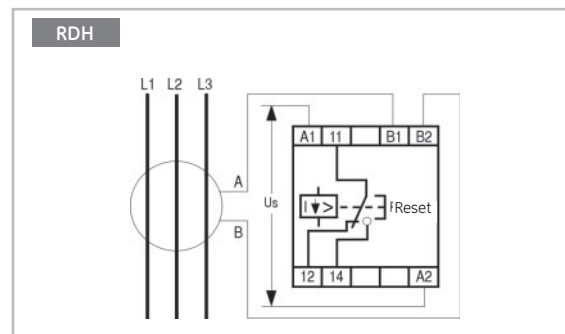

**Technical characteristics**

	RDHT1-...	RDHA1-...
Nr. of changeover contacts		1
Output contacts:		
Rated insulation voltage Ui	AC (V)	400
	DC (V)	250
Thermal current Ith	(A)	6
Utilisation AC-15		
Rated voltage Ue	(V)	120/240
Rated current Ie	(A)	2.5/1.3
Utilisation DC-13		
Rated voltage Ue	(V)	110/220
Rated current Ie	(A)	0.2/0.1
Supply voltages (Un)		
AC (with transformer)	(V)	380-400
		220-230
DC/AC (direct)	(V)	-
Frequency	(Hz)	50/60
Permissible supply voltage variation (%)		+10 / -15
Repeat accuracy with 0.85-1.1 Un (%)		2
Consumption (VA)		3
Input circuit test voltage (kV)		4
Switch ON response time (can be delayed up to 5 sec)	(s)	150-200
		100





## RDFF1... Integral protection relay for three-phase lines

### Function

- Protection against:
- a) Phase failure
  - b) Phase sequence
  - c) Phase unbalance
  - d) Low line voltage
  - e) High line voltage

Relay operates by phase angle detection between voltages and not by voltage levels and therefore will drive satisfactorily even with feedback from other motors.

Relays will connect only when all conditions are normal (contact 15-18 closes) and disconnects on any fault including supply, protecting network even with supply failure. It will not connect if phase sequence is incorrect, preventing motors starting in wrong direction.

#### Unbalance adjustment

Phase, unbalance, and therefore single phase is very dangerous for the life of a motor. The graph below shows temperature rise in a three-phase motor with a phase unbalance (NEMA MG 1-1433 and 34). The per cent unbalance is obtained as follow:

$$\% \text{ unbalance} = \frac{\text{Max. voltage deviation from average voltage}}{\text{average voltage}} \times 100$$

Tripping is adjustable between 2.5 and 10 %.

Consequently protection is provided for motors working closely adjusted to rated power, to others more generously sized, and even power lines.

In any case adjustments should be made so that on failure of one phase really will disconnect.

#### Voltage adjustment

Voltage tripping is adjustable from -5 to -20 % and +5 to +15 % maximum by which it is possible to adjust to values recommended by IEC 34.1 (1969) and IEC 158 respectively. Tripping for these causes is delayed 1 second approximately.

#### Tripping indication

Relays incorporate LED diode tripping indication. When phase sequence is incorrect, both phase sequence and unbalance light up. When unbalance lights up only indicates unbalance or single phasing with feedback.

### Ambient conditions

Storage temperature	-10°C to +85°C
Operating temperature	-5°C to +50°C
Relative humidity	95% (without condensation)
Altitude	2.000 m
Degree of protection	IP40; terminals IP20
Operating positions	Any

### Conformity to standards

VDE 0106	EN 50011	IEC/EN 60947-5-1
EN 50001	DIN 46199	CE
EN 50005	UNE 20-119	

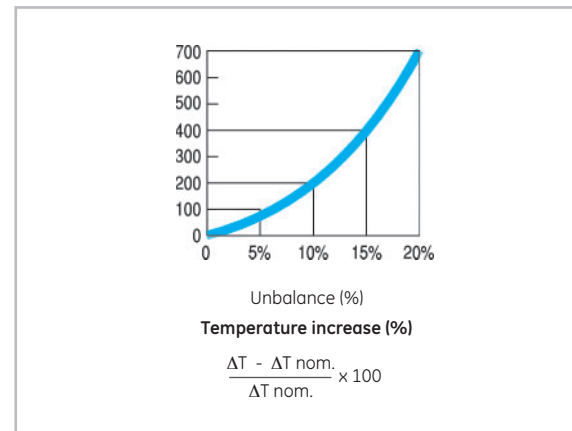
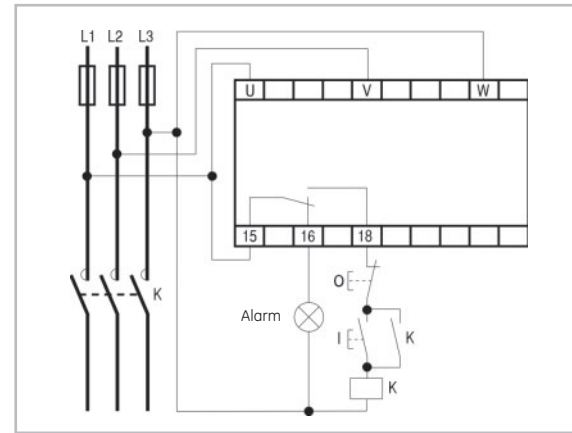

### Technical characteristics

		RDFF1-5
Nr. of changeover contacts		1
Output contacts:		
Rated insulation voltage Ui	AC (V)	400
	DC (V)	250
Thermal current Ith	(A)	6
Utilisation AC-15		
Rated voltage Ue	(V)	120/240
Rated current Ie	(A)	2.5/1.3
Utilisation DC-13		
Rated voltage Ue	(V)	110/220
Rated current Ie	(A)	0,2/0,1
Supply voltages (Un)		
AC (with transformer)	(V)	380
Frequency	(Hz)	50
Permissible supply voltage variation (%)		+15 / -20
Repeat accuracy with 0.85 - 1.1 Un (%)		2
Consumption (VA)		3
Input circuit test voltage (kV)		4
(between input, output circuit and earth)		
Unbalance tripping (adjustable) (%)		2.5 to 10
Low voltage tripping (adjustable) (%)		5 to 20
Overvoltage tripping (adjustable) (%)		5 to 15
Switch ON response time (ms)		200
Reset hysteresis (%)		5 approx.

Electronic relays of 45 mm

Intro

A

B

C

D

E

F

G

H

I

J/X



## RPDF... Unbalance and phase failure protection relay for three-phase lines

### Function

The RPDF-electronic relay is intended for the protection of lines or electronic motors against unbalance between phases or failure of one or more phases. Detection of unbalance or phase failure is done by measuring phase change and not by voltage levels. This guarantees correct working even when there are return paths due to motors running which are connected to the mains networks to be protected. The relay is made when all conditions are normal (contact 11-14 closed); the contacts open in the event of a failure. In this way, any failure, including that of the relay supply, will cause disconnection and so avoid the supply being left unprotected.

### Setting unbalance

The unbalance in phases and, consequently, the failure of one of these, is a limiting factor in the life of an electric motor. The graph below shows the percentage temperature increase in a three-phase motor as a function of the degree of unbalance (see standards NEMA MG 1-1433 and 34). The per cent unbalance is calculated as follows :

$$\% \text{ unbalance} = \frac{\text{Max. voltage deviation from average voltage}}{\text{average voltage}} \times 100$$

The trip is adjustable between about 2.5% and 10%. Consequently protection is provided for motors working closely adjusted to rated power, to others more generously sized, and even power lines. In any case, the adjustment must be such that the loss of a phase produces the opening of the relay.

### Ambient conditions

Storage temperature	-10°C to +85°C
Operating temperature	-5°C to +50°C
Relative humidity	95% (without condensation)
Altitude	2.000 m
Degree of protection	IP40; terminals IP20
Operating positions	Any

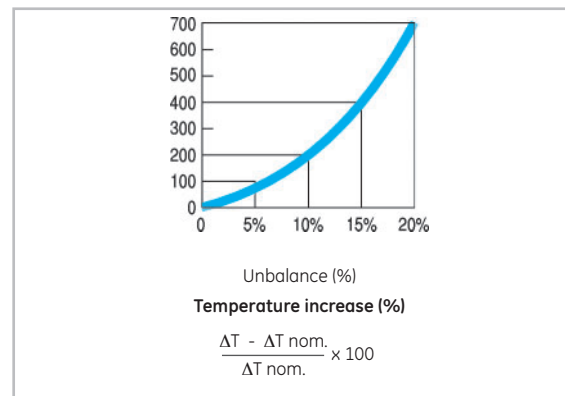
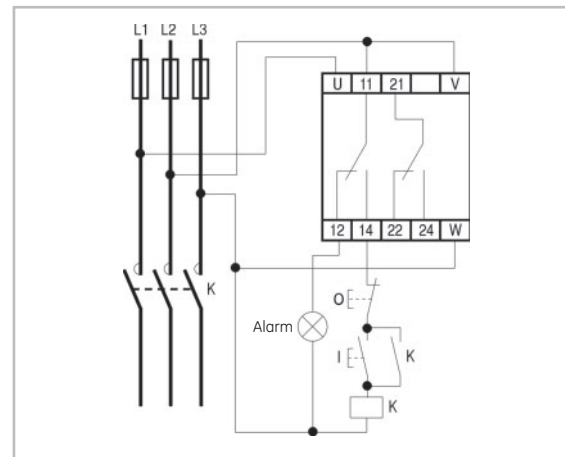

### Technical characteristics

	RPDF 2-50
Nr. of changeover contacts	2
Output contacts:	
Rated insulation voltage Ui	AC (V) 400
Rated insulation voltage Ui	DC (V) 250
Thermal current Ith	(A) 6
Utilisation AC-15	
Rated voltage Ue	(V) 120/240
Rated current Ie	(A) 2.5/1.3
Utilisation DC-13	
Rated voltage Ue	(V) 110/220
Rated current Ie	(A) 0,2/0,1
Supply voltages (Un)	
AC (with transformer)	(V) 380
Frequency	(Hz) 50
Permissible supply voltage variation (%)	+10 / -20
Repeat accuracy (%)	2
Consumption (VA)	3
Input circuit test voltage (kV)	4
(between input, output circuit and earth)	
Unbalance tripping (adjustable) (%)	2.5 to 10
Switch ON response time (ms)	100
Reset hysteresis (%)	2

### Conformity to standards

VDE 0106	IEC/EN 60947-5-1
EN 50001	UNE 20-119
EN 50005	CE
EN 50011	
DIN 46199	



## RSFF... Phase sequence and phase failure protection relay for three-phase lines

### Function

The RSFF relay is designed to detect phase sequence errors and/or phase failures in three phase lines. Three terminals **U, V, W** are connected to each of the three phases of the mains. Controlling vectors of voltage between lines (amplitude and phase) is detected the direct sequence (phase **V** with 120° in respect of **U** and phase **W** with 240° lag in respect and phase **U**) as well as balance of voltages and angles of phases, for detecting a phase failure even with returns (motor working).

By means of an external potentiometer can be adjusted the network unbalance, level, between 2,5 % and 105 % to adapt the relays sensibility for phase failure function. This unbalance is measured according to NEMA MG1-1433 and 34, and corresponds to a fall of simple tension of phase in amplitude of 7.3 and 28%, respectively. The relay precives either increases or drops of voltage and angle, then it detect the failures even in motors working as breaking devices (loads going down in lifting devices). When relay is powered, it connects instantaneously (max. 200ms) if the power system is correct. Once the switched on relay is switch-on, it switches-off with 1 sec. delay in case of a failure, to avoid false disconnections due to transient unbalances. (Start of other motors, transformers, etc.).

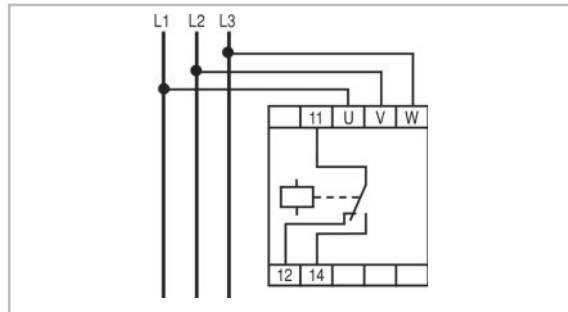

### Technical characteristics

		RSFF1-50
Nr. of changeover contacts		1
Output contacts:		
Rated insulation	AC (V)	400
voltage U <sub>i</sub>	DC (V)	250
Thermal current I <sub>th</sub>	(A)	6
Utilisation AC-15		
Rated voltage U <sub>e</sub>	(V)	120/240
Rated current I <sub>e</sub>	(A)	2.5/1.3
Utilisation DC-13		
Rated voltage U <sub>e</sub>	(V)	110/220
Rated current I <sub>e</sub>	(A)	0.2/0.1
Supply voltages	(U <sub>n</sub> )	
AC (with transformer)	(V)	380-400
Frequency	(Hz)	50/60
Permissible supply voltage variation (%)		+15 / -20
Repeat accuracy	(%)	2
Consumption	(VA)	3
Input circuit test voltage	(kV)	4
(between input, output circuit and earth)		
Switch ON response time	(ms)	200
Switch OFF response time	(s)	1

$$\% \text{ unbalance} = \frac{\text{max. voltage derivation from average voltage}}{\text{average voltage}} \times 100$$

## RSF... Phase sequence relay for three-phase lines

### Function

The RSF1 is designed to detect phase sequence in three phase power system. Three supplies **U, V, W**, take voltage from each of the phases of the network. When phase sequence supplying relay is direct (Phase **V** with 120° lag in respect of **U** and phase **W** with 120° lag in respect of **V**) the relays connects with supply (closes contact between **11-14**) and if no it remains OFF. For correct operation, relay must have supplying each of the three phases.

A phase failure, when there is a return current (the motor is rotating), is not detected by the relay and may lead to a relay malfunction.

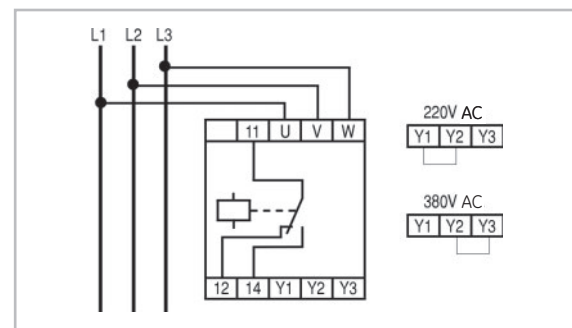

### Technical characteristics

		RSF1-50
Nr. of changeover contacts		1
Output contacts:		
Rated insulation	AC (V)	400
voltage U <sub>i</sub>	DC (V)	250
Thermal current I <sub>th</sub>	(A)	6
Utilisation AC-15		
Rated voltage U <sub>e</sub>	(V)	120/240
Rated current I <sub>e</sub>	(A)	2.5/1.3
Utilisation DC-13		
Rated voltage U <sub>e</sub>	(V)	110/220
Rated current I <sub>e</sub>	(A)	0.2/0.1
Supply voltages	(U <sub>n</sub> )	
AC (with transformer)	(V)	380-400 / 220-230 (two voltages)
Frequency	(Hz)	50/60
Permissible supply voltage variation (%)		+10 / -15
Repeat accuracy	(%)	2
Consumption	(VA)	3
Input circuit test voltage	(kV)	4
(between input, output circuit and earth)		
Switch ON response time	(ms)	500
Switch OFF response time	(ms)	200

### Ambient conditions

Storage temperature	-10°C to +85°C
Operating temperature	-5°C to +50°C
Relative humidity	95% (without condensation)
Altitude	2.000 m
Degree of protection	IP40; terminals IP20
Operating positions	Any

### Conformity to standards

VDE 0106	IEC/EN 60947-5-1	EN 50001	UNE 20-119
EN 50005	EN 50011	DIN 46199	CE

### Remark

The relay has one LED that lights when the output contact is made.

Electronic relays of 45 mm

Intro

A

B

C

D

E

F

G

H

I

J/X



## RTMM2 Maximum and minimum voltage protection relay for three-phase lines

### Function

The RTMM electronic relay is voltage sensitive and has one or two changeover output contacts. The relay maintains operated (contact between 11-14 or between 21-24 closed) while the voltage is within the tolerance limits and opens when these limits are surpassed in plus or minus. The relay can be used for low voltage or over-voltage detection in three-phase lines.

The trip value, for maximum and minimum voltage, are set by means of two independent potentiometer mounted on the relay front cover. The limits for the trip are adjustable between +5 and +15% for maximum voltage and between -5 and -20% for minimum voltage.

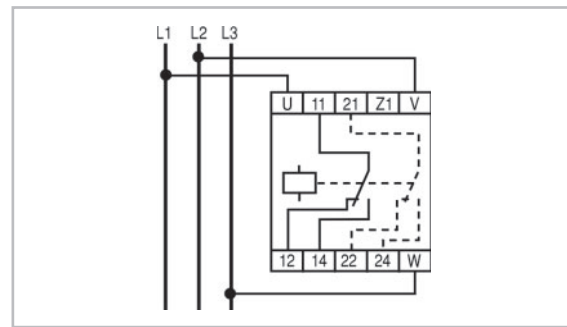

### Technical characteristics

		RTMM2
Nr. of changeover contacts		2
Output contacts:		
Rated insulation voltage $U_i$	AC (V)	400
	DC (V)	250
Thermal current $I_{th}$	(A)	6
Utilisation AC-15		
Rated voltage $U_e$	(V)	120/240
Rated current $I_e$	(A)	2.5/1.3
Utilisation DC-13		
Rated voltage $U_e$	(V)	110/220
Rated current $I_e$	(A)	0.2/0.1
Supply voltages (Un)		
AC (with transformer)	(V)	400,380,240,220
Frequency	(Hz)	50/60
Permissible supply voltage variation (%)		+20 / -20
Repeat accuracy (%)		2
Consumption (VA)		3
Input circuit test voltage (between input, output circuit and earth)	(kV)	4
Low voltage tripping (adjustable) (%)		-5 to -20
Over voltage tripping (adjustable) (%)		+5 to +15
Switch ON response time (ms)		100
Reset hysteresis (%)		2

### Ambient conditions

Storage temperature	-10°C to +85°C
Operating temperature	-5°C to +50°C
Relative humidity	95% (without condensation)
Altitude	2.000 m
Degree of protection	IP40; terminals IP20
Operating positions	Any

### Conformity to standard

VDE 0106
EN 50001
EN 50005
EN 50011
DIN 46199

IEC/EN 60947-5-1
UNE 20-119
CE

### Remark

The relay has one LED that lights when the output contact is made.

## RMM2 Maximum and minimum voltage relay for single-phase lines

### Function

These voltage-sensitive relays with one or two changeover output contacts remain connected (contact between 11-14 or between 21-24 closed) when voltage is within tolerance limits, and opens when voltage surpasses these limits in plus or minus. Relays can be used to detect low or lover voltage in balanced single or three-phase systems, and maximum and minimum tripping values are adjustable by means of two frontal potentiometers. The limits for the trip are adjustable between 5 and 15% for maximum voltage and between 5 and 20% for minimum voltage.

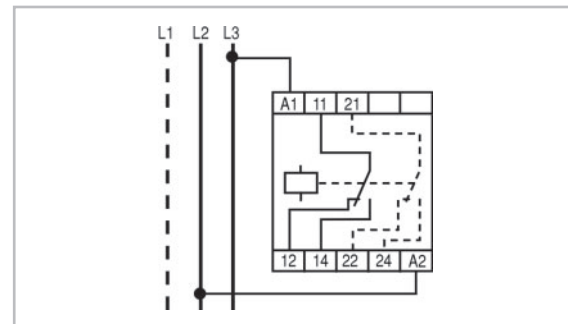

### Technical characteristics

		RMM 2
Nr. of changeover contacts		2
Output contacts:		
Rated insulation voltage $U_i$	AC (V)	400
	DC (V)	250
Thermal current $I_{th}$	(A)	6
Utilisation AC-15		
Rated voltage $U_e$	(V)	120/240
Rated current $I_e$	(A)	2.5/1.3
Utilisation DC-13		
Rated voltage $U_e$	(V)	110/220
Rated current $I_e$	(A)	0.2/0.1
Supply voltages (Un)		
AC	(V)	240,220
Frequency	(Hz)	50/60
Permissible supply voltage variation (%)		+15 / -20
Repeat accuracy (%)		2
Consumption (VA)		3
Input circuit test voltage (between input, output circuit and earth)	(kV)	4
Low voltage tripping (adjustable) (%)		-5 to -20
Over voltage tripping (adjustable) (%)		+5 to +15
Reset hysteresis (%)		5 approx.
Switch ON response time (ms)		100



**RDT2 Voltage detector relay <sup>(1)</sup>****Function**

The output contact in this voltage detector will connect when controlled voltage between terminals B1-B2 exceeds a certain adjustable threshold by means of the front potentiometer and will disconnect with a voltage 10% below the setting value.

The relay requires voltages supply between A1-A2. Controlled voltage can be either direct (DC) or alternating (AC). The output contact function can be set to NO by means of an internal jumper (contact 11-14 is normally closed and opens when control power supply or removal is detected at A1-A2).

When the distance between the measurement point and the relay is greater than 1m, in order to avoid any noise problems, connection to the B1-B2 terminals should be made by using a shielded cable, with its screen joined to the B2 terminal and isolated at the other cable end or by using a twisted-pair cable.

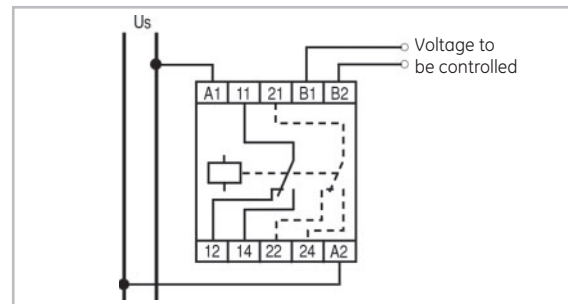
**Technical characteristics**

		RDT2-...
Nr. of changeover contacts		2
Output contacts:		
Rated insulation voltage U <sub>i</sub>	AC (V)	400
	DC (V)	250
Thermal current I <sub>th</sub>	(A)	6
Utilisation AC-15		
Rated voltage U <sub>e</sub>	(V)	120/240
Rated current I <sub>e</sub>	(A)	2.5/1.3
Utilisation DC-13		
Rated voltage U <sub>e</sub>	(V)	110/220
Rated current I <sub>e</sub>	(A)	0.2/0.1
Supply voltages	(Un)	
AC	(V)	220-230
Frequency	(Hz)	50/60
Permissible supply voltage variation		+10 / -15
	(%)	
Consumption	(VA)	3,7
Input circuit test voltage	(kV)	2,5
(between input, output circuit and earth)		
Reset hysteresis	(%)	10
Switch ON response time	(ms)	100

**Ambient conditions**

Storage temperature	-10°C to +85°C
Operating temperature	-5°C to +50°C
Relative humidity	95% (without condensation)
Altitude	2.000 m
Degree of protection	IP40; terminals IP20
Operating positions	Any

**Conformity to standards**

VDE 0106	IEC/EN 60947-5-1
EN 50001	UNE 20-119
EN 50005	CE
EN 50011	
DIN 46199	

**RDIT2 Current detector relay <sup>(2)</sup>  
with delay (0.5-15 seconds)****Function**

This relay is similar to the RDI except that it will connect with a certain adjustable delay of **0.5 to 15 secs.** If current falls below threshold before timeout, relay will reset immediately to recount delay from zero. For higher currents, current transformers or shunts of suitable ratios can be used. The relay requires voltages supply between A1-A2. Controlled voltage can be either direct (DC) or alternating (AC). The output contact function can be set to NO (the 15-18 contact closes when the delay time has elapsed) or to NC (the 15-18 contact is normally closed and opens when the delay time has elapsed or when the control power supply is removed from **A1-A2**) by means of an internal jumper. The **0.2 V** version has been designed to be used with an external shunt and if the distance between the shunt and the relay is greater than 1 m, a connection to the **B1-B2** terminals should be made by using a shielded cable, with its screen joined to the **B2** terminal and isolated on the shunt side or by using a twisted-pair cable.

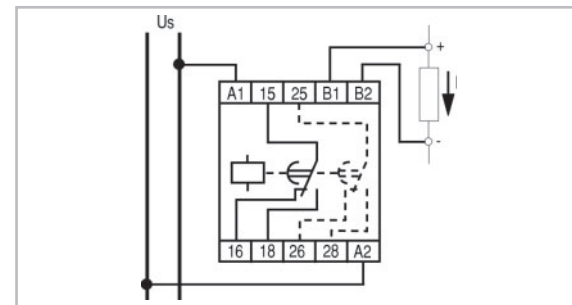
**Technical characteristics**

		RDIT2-...
Nr. of changeover contacts		2
Output contacts:		
Rated insulation voltage U <sub>i</sub>	AC (V)	400
	DC (V)	250
Thermal current I <sub>th</sub>	(A)	6
Utilisation AC-15		
Rated voltage U <sub>e</sub>	(V)	120/240
Rated current I <sub>e</sub>	(A)	2.5/1.3
Utilisation DC-13		
Rated voltage U <sub>e</sub>	(V)	110/220
Rated current I <sub>e</sub>	(A)	0.2/0.1
Supply voltages	(Un)	
AC (with transformer)	(V)	220-230
Frequency	(Hz)	50/60
Permissible supply voltage variation		+10 / -15
	(%)	
Repeat accuracy with 0.8 -1.1 Un	(%)	2
Consumption	(VA)	3
Input circuit test voltage	(kV)	4
(between input, output circuit and earth)		
Switch OFF response time	(s)	0.5 to 15
Reset time between 2 cycles <sup>(3)</sup>	(ms)	100

**(1) Remark**

The relay has a green LED which lights up when the supply is between A1 and A2, and a red LED when the contact is made (11-14).

**(2) Remark**

The relay has a yellow LED which lights up when the supply is between A1 and A2, and a red LED when the contact is made **15-18**.

**(3) Remark**

Reset time: Time that must go by from the relay ends an operation until it is able to initiate the next one without error.

Electronic relays of 45 mm

Intro

A

B

C

D

E

F

G

H

I

J/X



## RS01N Thermistor relay

### Function

This thermal probe relay is sensitive to resistance of several thermal probes (thermistors, PTC) connected to **P1** and **P2** and detect overheating in motor windings transformers, etc. where these PTC are connected.

The relays disconnects when probe resistance exceeds 2500 ohms and cannot reset until resistance is lower than 1500 ohms. Control voltage should be applied to **A1** and **A2**, the absence of this will cause relay to trip and prevent any possibility remaining without protection. In this case resetting is automatic, but if the relay trips through probe heating, resetting may be automatic, hand or remote (distance NC contact).

RS01N detect those cases of probe cables short-circuited (resistance lower than 20 Ohms) or probe cables cut (resistance higher than 2.5k Ohms). The resistance at 25 °C of the probe circuit must be within 40 to 600 ohms range.

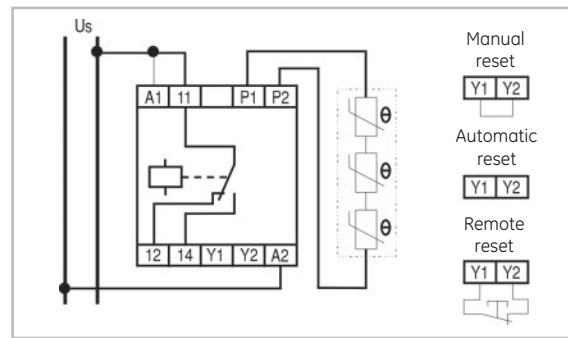

### Technical characteristics

		RS01N
Nr. of changeover contacts		1
Output contacts:		
Rated insulation voltage $U_i$	AC (V)	400
	DC (V)	250
Thermal current $I_{th}$	(A)	6
Utilisation AC-15		
Rated voltage $U_e$	(V)	120/240
Rated current $I_e$	(A)	2.5/1.3
Utilisation DC-13		
Rated voltage $U_e$	(V)	110/220
Rated current $I_e$	(A)	0.2/0.1
Supply voltages (Un)		
AC (with transformer)	(V)	220-230,125,110
Frequency	(Hz)	50/60
Permissible supply voltage variation (%)		+10 / -15
Repeat accuracy with 0.85-1.1 Un (%)		2
Consumption	(VA)	3
Input circuit test voltage (between input, output circuit and earth)	(kV)	4
Switch OFF response time	(s)	100
Hysteresis	(kOhms)	1
Probe resistance min. (at 25°C) (Ohms)		40
Probe resistancemax. (at 25°C) (Ohms)		600
Max. voltage in terminals P1-P2 ( $R=2.5kV/M$ )		< 1,6

### Ambient conditions

Storage temperature	-10°C to +85°C
Operating temperature	-5°C to +50°C
Relative humidity	95% (without condensation)
Altitude	2.000 m
Degree of protection	IP40; terminals IP20
Operating positions	Any

### Conformity to standards

VDE 0106	IEC/EN 60947-5-1
EN 50001	IEC 34-11-2 (RS01N)
EN 50005	UNE 20-119
EN 50011	CE
DIN VDE 0660-303 (RS01N)	
DIN 46199 (RSR)	

### Remark

The relay has one LED that lights when the output contact is made.



## RCF 1 Frequency control relay

### Function

This frequency control relay is sensitive to frequency of the signal applied to terminals **B1** and **B2** and output contact connects when frequency fails below a threshold adjustable by the front potentiometer. Supply voltage should also be applied to relay between terminals **A1** and **A2** to produce connection. Possibility of three settings ranges (by cross-connection): 5-15Hz, 15-45Hz, 45-135Hz.

Switching is independent of input signal level at **B1-B2**, within a wide range of values, and response is not changed by the input signal wave form (sinusoidal, square, triangular, etc).

Relay is suitable for suppression of rotor resistance in slipping asynchronous motors starters, speed reversal detector in motor wound motors and frequency control in generating sets.

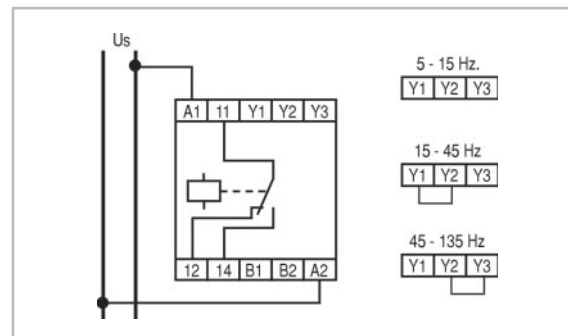

### Technical characteristics

	RCF-1	
Nr. of changeover contacts	1	
Output contacts:		
Rated insulation voltage $U_i$	AC (V)	400
	DC (V)	250
Thermal current $I_{th}$	(A)	6
Utilisation AC-15		
Rated voltage $U_e$	(V)	120/240
Rated current $I_e$	(A)	2.5/1.3
Utilisation DC-13		
Rated voltage $U_e$	(V)	110/220
Rated current $I_e$	(A)	0.2/0.1
Supply voltages	(Un)	
AC (with transformer)	(V)	380-400,220,230,110
Frequency	(Hz)	50/60
Permissible supply voltage variation(%)		+10 / -15
Voltage between B1-B2 terminals(V c.a.)		15 to 500
Repeat accuracy with 0.85-1.1 $U_n$ (%)		2
Consumption	(VA)	3
Input circuit test voltage	(kV)	4
(between input, output circuit and earth)		
Switch ON response time	(ms)	100
Switch OFF response time	(ms)	800
Reset hysteresis	(Hz)	1.5 approx.

### Ambient conditions

Storage temperature	-10°C to +85°C
Operating temperature	-5°C to +50°C
Relative humidity	95% (without condensation)
Altitude	2.000 m
Degree of protection	IP40; terminals IP20
Operating positions	Any

### Conformity to standards

VDE 0106	EN 50042 (MRI)
VDE 0110 (MRI)	DIN 46199 (RCF)
EN 50001 (RCF)	IEC/EN 60947-5-1
EN 50002 (MRI)	UNE 20-119 (RCF)
EN 50005	UL 94 (MRI)
EN 50011	UL 508 (MRI)
CE	

### Remark

The relay has one LED that lights when the output contact is closed.

Electronic relays of 45 mm

Intro

A

B

C

D

E

F

G

H

I

J/X



Dimensional drawings

Series NMV

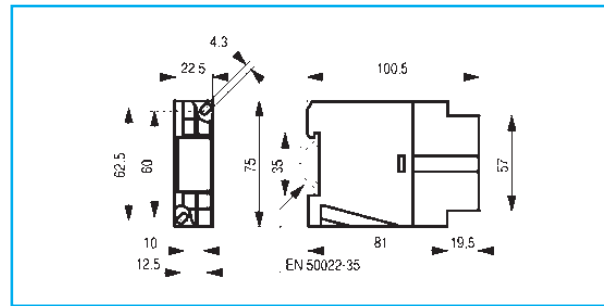

Series D

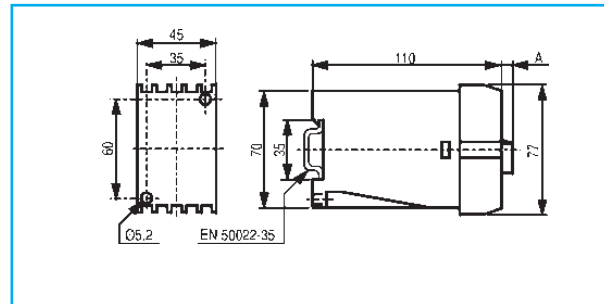

RET, RTC, RTCI, RRD, RTD, RIC, RCR, DINIL-02, DINIL-03, RTMM, RDI, RDIA RSR, RCF RS01N	A
	4
	8

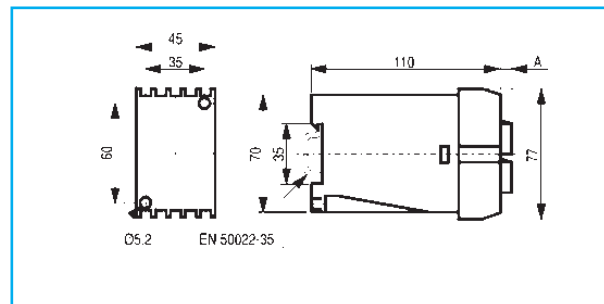
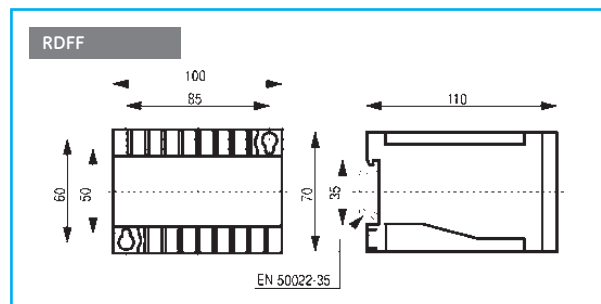
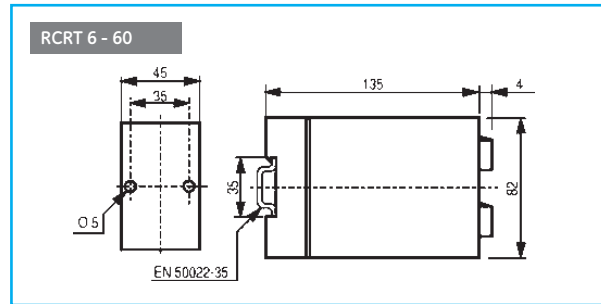

RDMT, RPDF, RMM, RDT, RDTA, RDIT, RDITA RDH, RDHT, RDHA	A
	4
	12

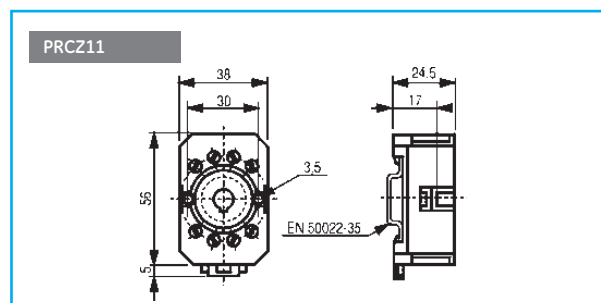
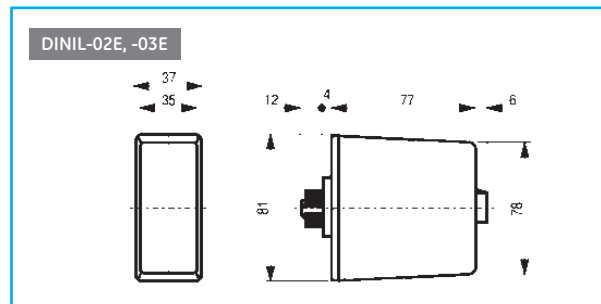



Differential transformers

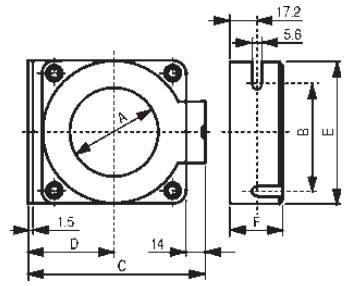

TYPE	A	B	C	D	E	F
WKA-35	35	75	99	42	92	33.5
WKA-70	70	98	132	60.5	115	33.5
WKA-105	105	141	175	82	158	33.5
WKA-140	140	183	218	103.5	200	33.5
WKA-210	210	270	309	150	290	43
WKAT-35	35	75	99	42	92	33.5
WKAT-70	70	98	132	60.5	115	33.5
WKAT-105	105	141	175	82	158	33.5
WKAT-140	140	183	218	103.5	200	33.5
WKAT-210	210	270	309	150	290	43

Remote potentiometer

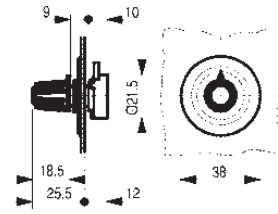

Electronic relays

Intro

A

B

C

D

E

F

G

H

I

J/X





**Metal and thermoplastic limit switches.  
Positive opening. Conformity with EN 50041.**

- Fixing center lines and operation points in accordance with EN 50041
- NC contacts with positive opening to IEC/EN 60947-5-1
- IP65 protection
- Terminal numbering according to IEC/EN 50013
- Cable entry M20 x 1.5
- Safety switches according to cat. 1 of IEC/EN 60947-5-1 (depends on actuating system)
- CSA and UL certified

**Standards**

IEC/EN 60947-5-1  
IEC/EN 60204-1

**Approvals**



**Mounted versions**

**Series IS...**

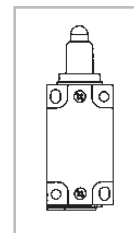

- Double-insulated bodies, in **thermoplastic material, according to UL-94 VO**
- Clip-fixing and opening of terminal access cover, no screws.

**Series IM...**

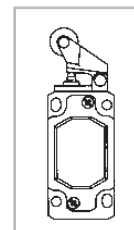

- Metal bodies constructed from injected **aluminium**.
- Cover fastening by screws.









**Specifications**

Degree of protection	IP65
Ambient conditions	
Storage temperature	°C -40 to +80
Operating temperature	°C -25 to +80
Resistance to shocks (10 ms)	G 30
Resistance to vibrations (10-55 Hz)	G 25
Mechanical endurance	ops. 10 x 10 <sup>6</sup>
Cable entry	M20 x 1.5
Fixing screws	4 x M5

Order codes ● pg. G.3  
Technical data ● pg. G.10  
Dimensions ● pg. G.11



Limit switches according to EN 50041

	Mounting position of the head <sup>(1)</sup>			Slow break		Snap action		Pack
	Heads Standard position	Head position	Form to EN 50041	Cat. no	Ref. no.	Cat. no	Ref. no.	
	Plunger	III	B	ISGA-B211	130000	ISGA-B411	130018	5
		III	B			IMGA-B411	130019	
	Roller plunger	III	C			ISGR-B411	130020	5
		III	C			IMGR-B411	130021	
	Roller level	III	(1)			ISGH-B411	130022	5
		III	(1)			IMGH-B411	130023	
	Roller crank	III	A			ISGL-B411	130028	5
		III	A			IMGL-B411(4)	130029	
	Adjustable roller crank <sup>(2)</sup>	II	(1)			ISGT-B311	130030	5
		II	(1)			IMGT-B311	130031	
	Rod lever <sup>(2)</sup>	II	D			IMGP-B311	130035	5
	Cross rod	II	(1)			IMGC-B411	130037	5
	Spring rod lever <sup>(2)</sup>	III	(1)			IMGQ-B311	130039	5
	Omnidirectional spring rod <sup>(2)</sup>	III	(1)			ISGM-B311	130040	5
		III	(1)			IMGM-B311	130041	

 Positive break

- (1) Fixing center lines and operation points in accordance with EN 50041.
- (2) Heads for these limit switches have no positive opening, as they are adjustable or flexible.
- (3) Supplied in standard mounting position. Positions II and III must be set by user.
- (4) Available with metal roller lever: IMGL-B411M (130107).

Order codes

Intro

A

B

C

D

E

F

G

H

I

J/X



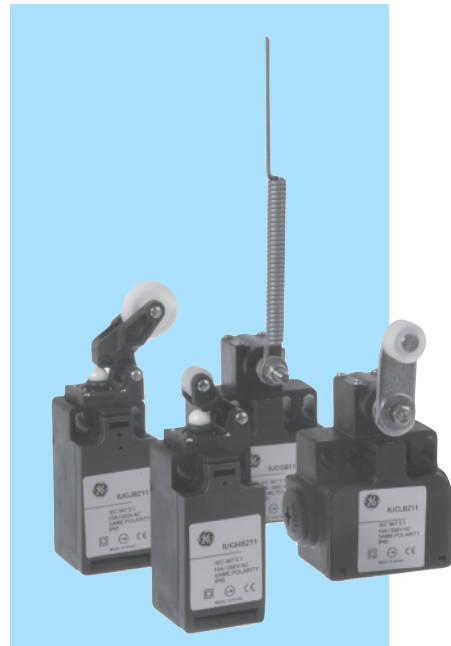

**Thermoplastic limit switches.  
Positive opening. Conformity with EN 50047.**

- Fixing center and operation points in accordance with EN 50047
- NC contacts with positive opening according to IEC/EN 60947-5-1
- IP65 protection
- Terminal numbering according to EN 50013
- Thermoplastic material according to UL-94 V0
- One bottom cable entry M20x1.5 on Series IUG
- Two fixing possibilities for series IUGA...
- Clip fixing and opening of terminals access cover, no screws.
- CSA and UL certified

**Standards**

IEC/EN 60947-5-1  
IEC/EN 60204-1

**Specifications**

Degree of protection	IP 65
Ambient conditions	
Storage temperature	°C -40 to +80
Operating temperature	°C -25 to +80
Resistance to shocks (10 ms)	G 30
Resistance to vibrations (10-55 Hz)	G 25
Mechanical endurance	ops. 10 x 10 <sup>6</sup>
Cable entry	IUG... 1 x (M20x1.5)
Fixing screws	2 of M5

**Approvals**



**Mounted versions**

Series IUG...

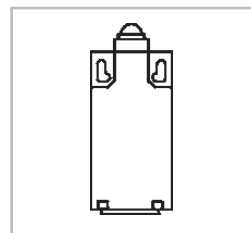











**Switch function**

Contact type	Switch function	Switch contacts	Voltage	Current
IUG Slow make & break	Changeover	1NC/1NO	250V	10A
Snap action	Changeover	1NC/1NO	250V	10A

Order codes ● pg. G.5  
 Technical data ● pg. G.10  
 Dimensions ● pg. G.13



Limit switches according to EN 50047

	Mounting position of the head		Slow break		Snap action		Pack	
	Heads Standard position	Head position	Form to EN 50047	Cat. no.	Ref. no.	Cat. no.		Ref. no.
	II	III	B	IUGA-B211 <sup>(3)</sup>	130060	IUGA-B411	130082	5
			B	IUGA-B211 S <sup>(3)</sup>	209140			5
	III	III	<sup>(2)</sup>			IUGU-B411	130084	5
			<sup>(2)</sup>	IUGU-B211 S <sup>(3)</sup>	130057			5
	III	III	<sup>(2)</sup>			IUGR-B411	130086	5
	III	III	E			IUGH-B411	130088	5
	III	III	<sup>(2)</sup>			IUGI-B411	130090	5
	III	III	<sup>(2)</sup>			IUGE-B411	130094	5
	III	III	A			IUGL-B411	130096	5
	II	II	<sup>(2)</sup>			IUGT-B311	130098	5
	II	II	<sup>(2)</sup>			IUGP-B311	130100	5
	III	III	<sup>(2)</sup>			IUGQ-B311	130102	5
	III	III	<sup>(2)</sup>			IUGM-B311	130104	5

(1) Heads for these limit switches have no positive opening.  
 (2) Fixing centre lines and operating points according to EN 50047.  
 (3) with latch  
 Positive break

Order codes

Intro

A

B

C

D

E

F

G

H

I

J/X



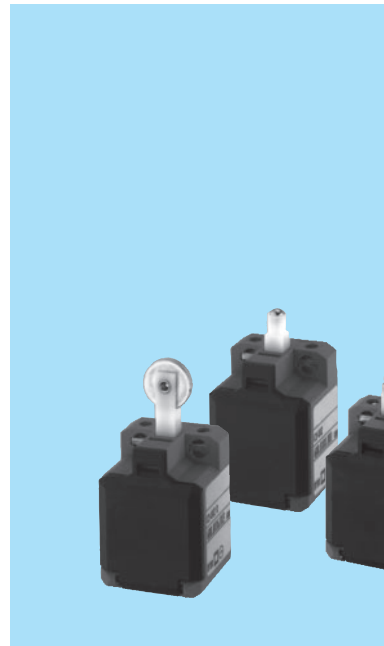

**Miniature thermoplastic limit switches**

- The small sizes makes these ideal for use in reduced spaces
- With slow break, NC contacts with positive opening according to IEC/EN 60947-5-1
- 2 mm contact opening of slow-action system according to EN 81-1 for lift application
- IP30 protection
- Terminal numbering according to EN 50013
- Thermoplastic material in accordance with UL-94 V0
- Clip fixing and opening of the contact access cover, no screws
- Two fixing possibilities: 2 x M3 from the top  
2 x M4 for mounting from the front

**Approvals**



**Switch function**



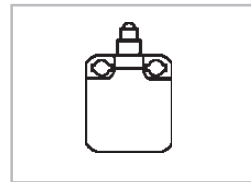

Contact type	Switch function	Switch contacts	Voltage	Current
Slow make & break	Changeover	1NC/1NO	250V	10A
Snap action	Changeover	1NC/1NO	250V	10A

**Mounted versions**

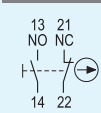

- Order codes ● pg. G.6
- Technical data ● pg. G.10
- Dimensions ● pg. G.15

**Miniature limit switches**

	Slow break		Snap - action		Pack
	Cat. no.	Ref. no.	Cat. no.	Ref. no.	
 Heads Plunger	 11 23 NC NO 12 24		 13 21 NO NC 14 22		
 Push-button (adjustable)	IZMS-B211	130141	IZMS-B311	130145	10
 Roller plunger			IZMR-B311	130146	10



**Stainless steel limit switches - Heavy duty - IP40**

*Mounted versions*

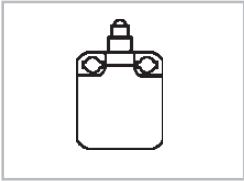

Dimensions ● pg. G.35

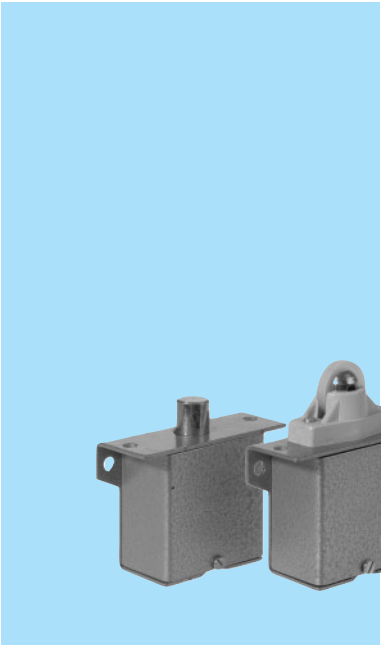

*Approvals*



**Stainless steel limit switches**

		Slow break	
		13 21 NO NC	14 22
		Cat. no.	Ref. no.
	Heads Plunger	IP	201942
	Ball	IB	201943
	Roller plunger	IR	201944

**Order codes**

Intro

A

B

C

D

E

F

**G**

H

I

J/X



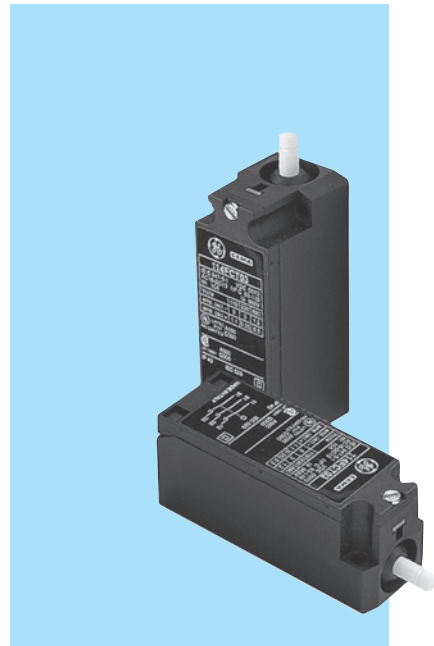

### Three pole limit switches

- Switch-box, cover and operation plunger by thermoplastic resin.
- Silver contacts.
- Lockable cover with one screw only.
- Two basic versions:
  - Without seal Protection IP40 according to IEC 529
  - With seal Protection IP65 according to IEC 529 (Types NEMA 1, 12 and 13 according to UL, ENCL. 3 according to CSA)
- Four electrical functions for both versions.
- Slow operation contacts, double-break and positive break of NC contacts.
- With screws, retractable and captive clamp type. Protection against accidental contact with live parts, degree of protection IP2x according to IEC 529.

### Standards

IEC/EN 60947-5-1  
 VDE 0660  
 BSI 4794  
 NFC 63140

### Approvals



### Actuating force

Minimum actuating force	
114FCT03, ...03T	7.5N
114FCT12, ...12T	10N
114FCT21, ...21T	12N
114FCT30, ...30T	13N
Positive opening force	
114FCT03, ...03T	8.5N
114FCT12, ...12T	8.5N
114FCT21, ...21T	8.5N
114FCT30, ...30T	-
Maximum force	
114FCT03, ...03T	12N
114FCT12, ...12T	13.5N
114FCT21, ...21T	15.5N
114FCT30, ...30T	17N

### Specifications

Mechanical performances	
Climatic protections	
Temperate climate (DIN 50014)	23 / 50
Wet climate (DIN 50015)	23 / 83
Hot wet climate (DIN 50015)	40 / 92
Variable wet climate (DIN 50016)	FW 24
Temperature ranges	
Operation	-25°C to +70°C
Storage	-40°C to +70°C
Vibrations resistance (according to IEC 68-2-6)	10G with frequency range from 1 to 100Hz
Mechanical endurance	10 x 10 <sup>6</sup> operations
Operation speed	
Min.	0.25 m/sec.
Max.	1 m/sec.
Electrical performances	
Rated insulation voltage (Ui) EN 60947.1	690V
Impulse withstand voltage (Uimp) EN 60947.1	4kV
Insulation class according to VDE 0660	Group C
Electrical shocks protection IEC 536	Class II (double insulation)
Short-circuit protection according to IEC 269.1 and 269.3	10A
Rated thermal current: I <sub>th</sub>	10A
Performances according to IEC 947.5.1	
Cat. AC15	Voltage U <sub>e</sub> (V) 24 48 60 110 220 380 500 600
	Current I <sub>e</sub> (A) 10 10 10 6 3 2 1.5 1.2
Cat. DC13	Voltage U <sub>e</sub> (V) 24 48 60 110 220 300
	Current I <sub>e</sub> (A) 2.5 1.4 1 0.55 0.27 0.2
Performances according to UL and CSA	
	AC / Heavy duty (A600)
	DC / Standard duty (Q300)
Terminals	
Capacity	min. 22 AWG (0.32mm <sup>2</sup> )
Rigid and/or flexible conductors	max. 12 AWG (3.3mm <sup>2</sup> )
Cable entry	1 x PG11

Order codes ● pg. G.9  
 Dimensions ● pg. G.15





Three pole limit switches



Contacts	Diagrams	Protection	Cat. no.	Ref. no.	Pack.
		IP40	<b>114FCT03</b>	130320	1
		IP65	<b>114FCT03T</b>	130321	1



		IP40	<b>114FCT12</b>	200909	1
--	--	------	-----------------	--------	---

Three pole insulated jumper



		IP40	<b>114FCT21</b>	200910	1
		<b>105PT</b> 132234    1			

Order codes

Intro

A

B

C

D

E

F

**G**

H

I

J/X



Technical data

Limit switches

		ISG.-B211 IMG.-B211	ISG.-B311 IMG.-B311 ISG.-B411 IMG.-411	IUG.-B111 IUG.-B211	IUG.-B311 IUG.-B411	IZM.-B211	IZM.-B311
Type of break		Slow break	Snap action	Slow break	Snap action	Slow break	Snap action
Number of contacts		2	2	2	2	2	2
Function		1NO-1NC	1NO-1NC	1NO-1NC	1NO-1NC	1NO-1NC	1NO-1NC
Polarity		Same	Same	Same	Same	Same	Same
Rated thermal current (I <sub>the</sub> )	(A)	10	10	10	10	10	10
<i>Auxiliary contacts</i>							
Rated insulation voltage (U <sub>i</sub> )V		400	400	250	250	380	250
Protection against electrical shocks		Class II (ISG) CLASS I (IMG)	Class II (ISG) CLASS I (IMG)	Class II	Class II	-	-
Protection against electrical shocks (fuse) (A)		10	2	10	2	6	6
Rated current (DIN EN60947-5-1)							
A300 AC-15	12/24V	(A)	-	-	-	-	-
	48/60V	(A)	-	-	-	-	-
	(110V) 120V	(A)	6	6	6	6	6
	127V	(A)	-	-	-	-	-
	(220V) 240V	(A)	3	3	3	3	3
	380V	(A)	-	-	-	-	-
Q300 DC-13	24V	(A)	-	-	-	-	-
	48V	(A)	-	-	-	-	-
	(110V) 125V	(A)	0.55	0.55	-	0.55	0.55
	(220V) 250V	(A)	0.27	0.27	-	0.27	0.27
	300V	(A)	-	-	-	-	-
Operating rate	ops./h	6000	6000	6000	6000	6000	6000
Switching time	(ms)	-	10	-	10	-	10
Repetition assurance	(mm)	± 0.1	± 0.1	± 0.1	± 0.1	± 0.1	± 0.1
Clamping capacity	(mm <sup>2</sup> )	0.5 - 1.5	1.5	1.5	1.5	1.5	1.5
Terminal screw		M3.5	M3.5	M3.5	M3.5	M3.5	M3.5
Protection		IP65	IP65	IP65	IP65	IP30	IP30

- Limit switches
- Intro
- A
- B
- C
- D
- E
- F
- G
- H
- I
- J/X



Dimensional drawings

Contact block Series IS

Common for all limit switches Series IS

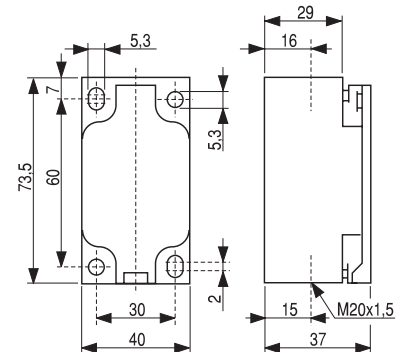

Contact block Series IM

Common for all limit switches Series IM

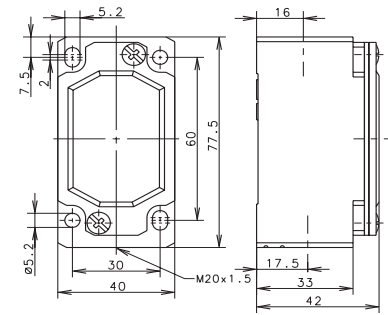

Operating heads

ISGA B..., IMGA B...

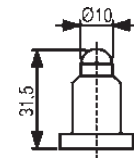

ISGH B..., IMGH B...

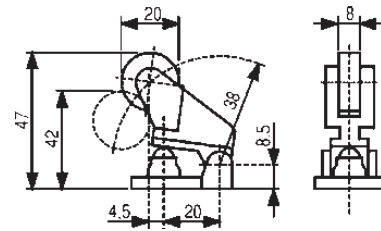

ISGR B..., IMGR B...

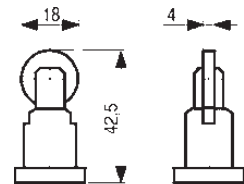

Dimensions

Intro

A

B

C

D

E

F

G

H

I

J/X



Dimensional drawings

Operating heads (continued)

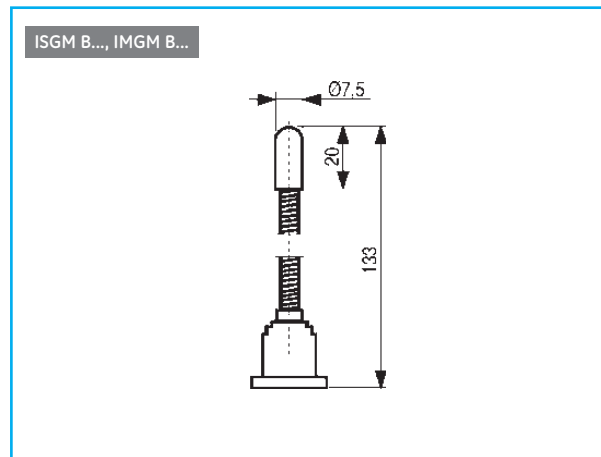
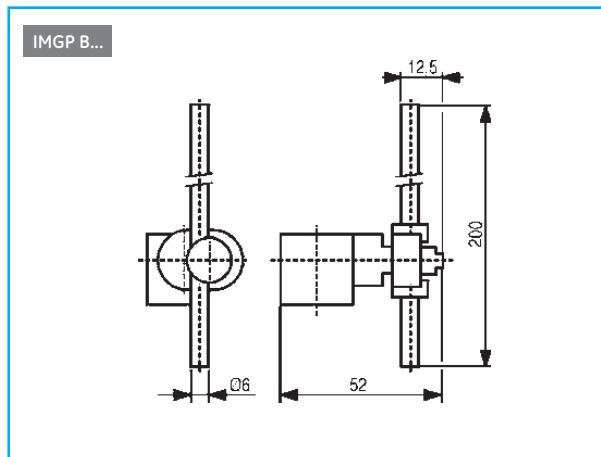
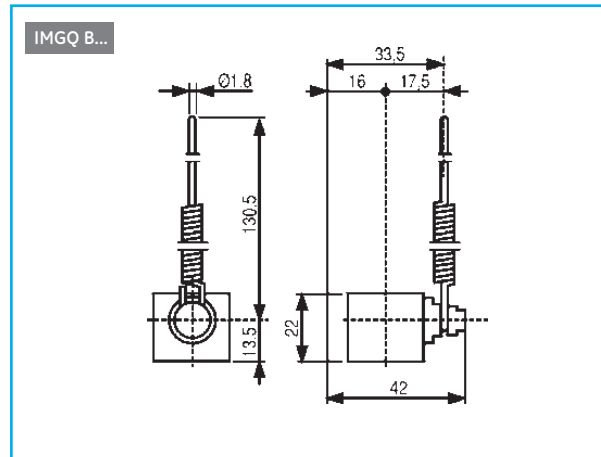
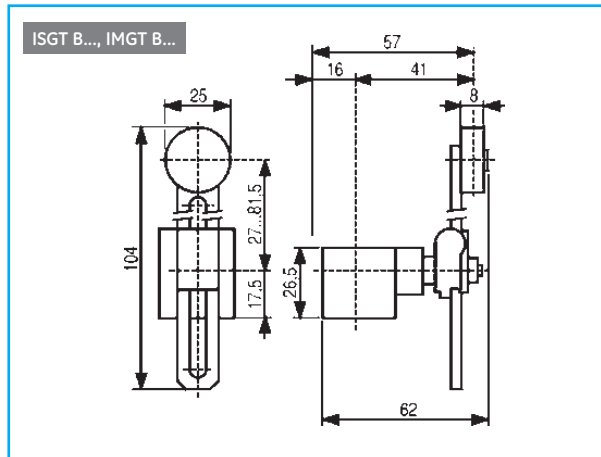
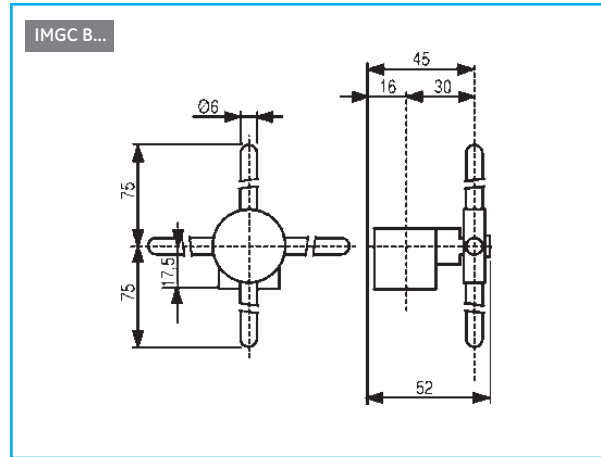
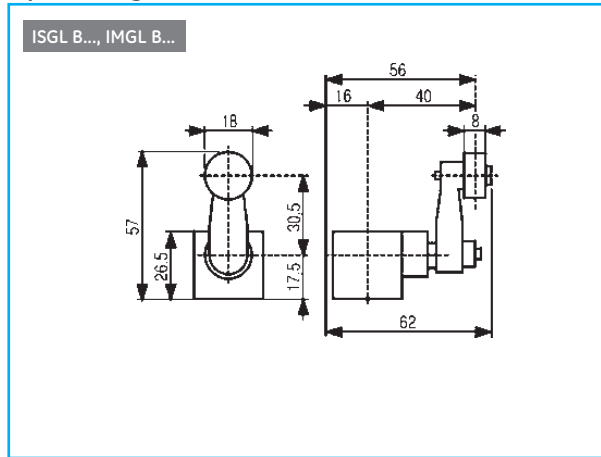

**Contact block Series IUG**

Common for all limit switches Series IUGA B...

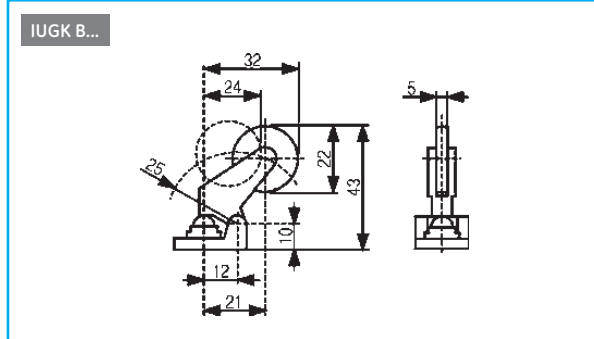
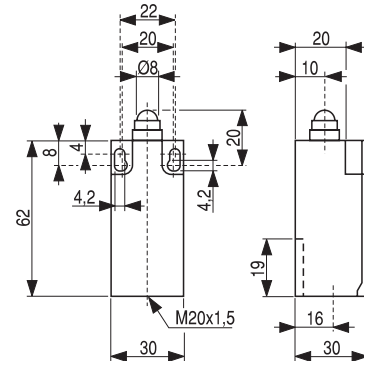

**Operating heads**

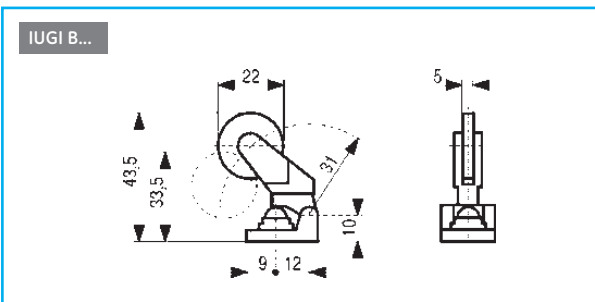
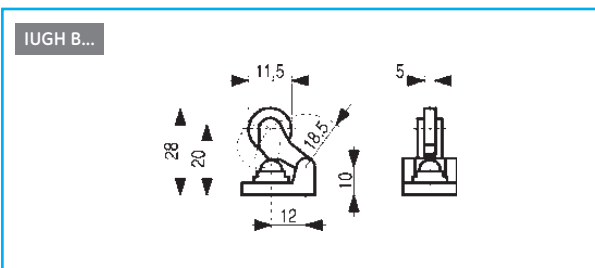
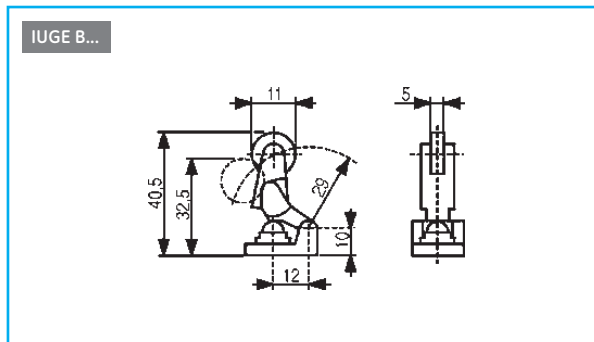
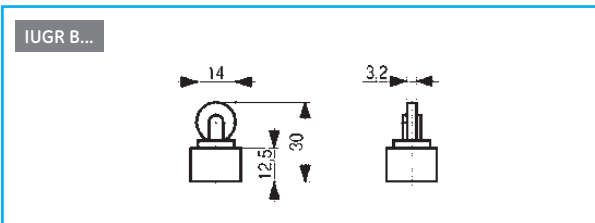
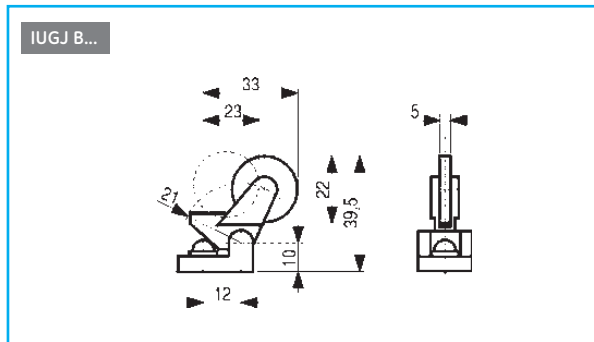
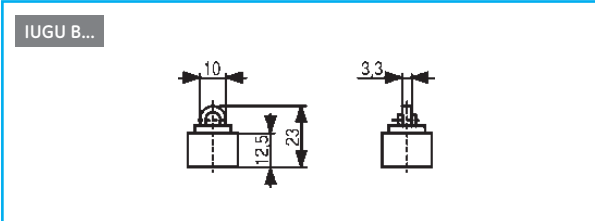

**Dimensions**

Intro

A

B

C

D

E

F

**G**

H

I

J/X



Dimensional drawings

Operating heads (continued)

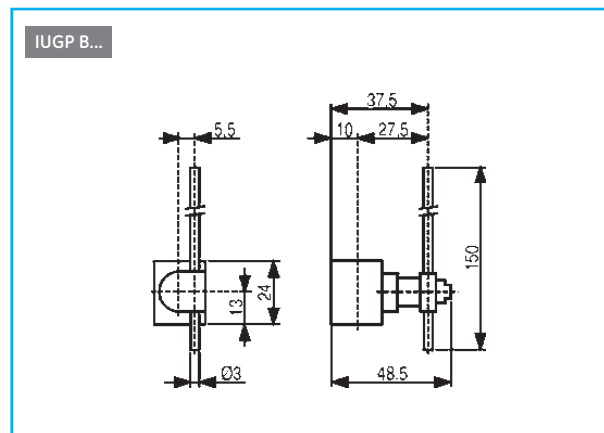
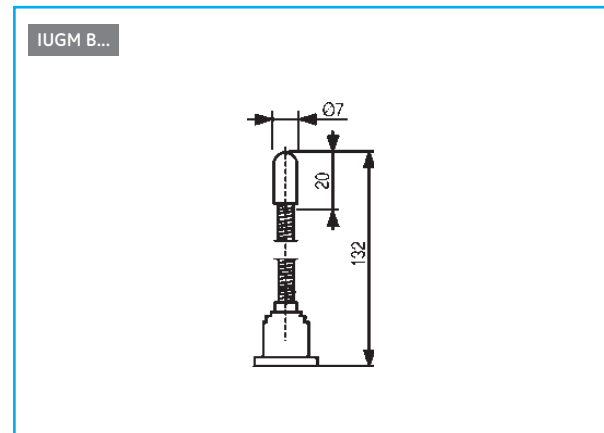
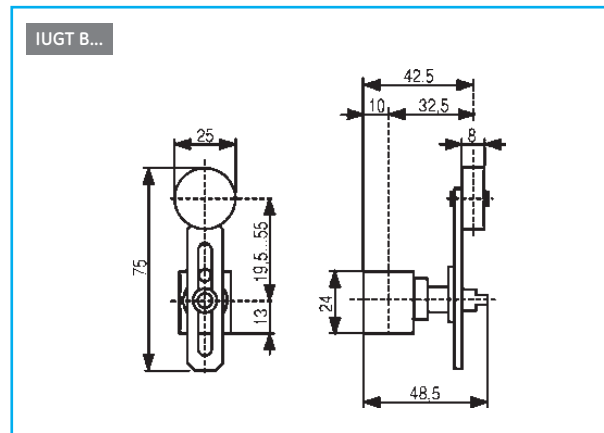
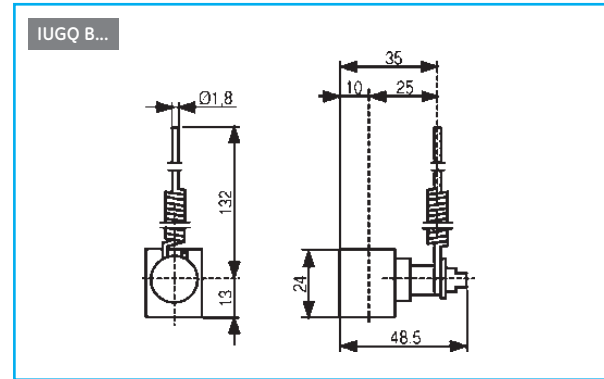
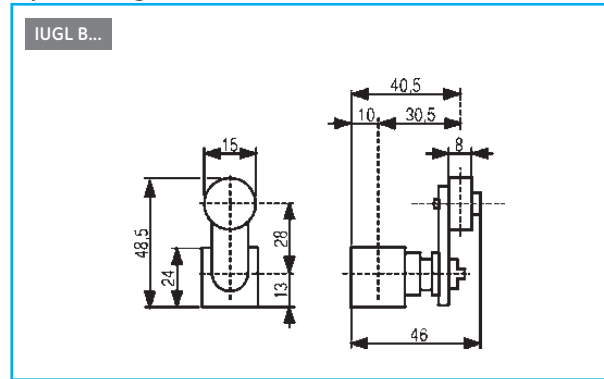

Limit switches

Intro

A

B

C

D

E

F

G

H

I

J/X



Series IZ

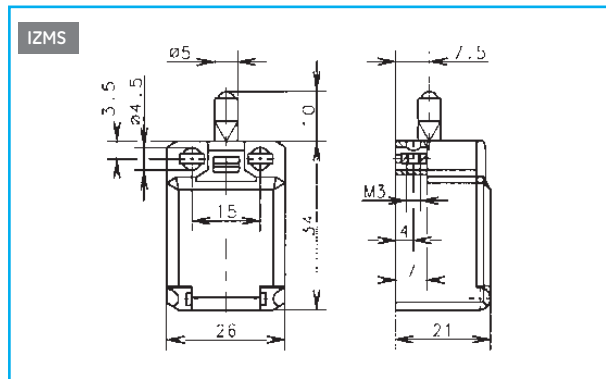
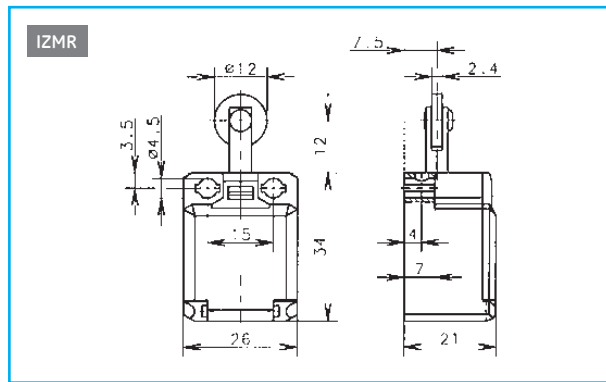
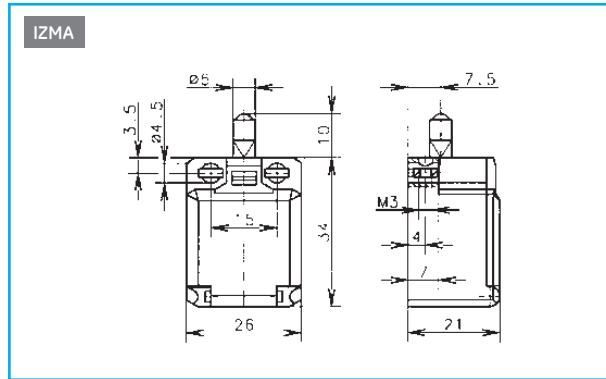

Series IP

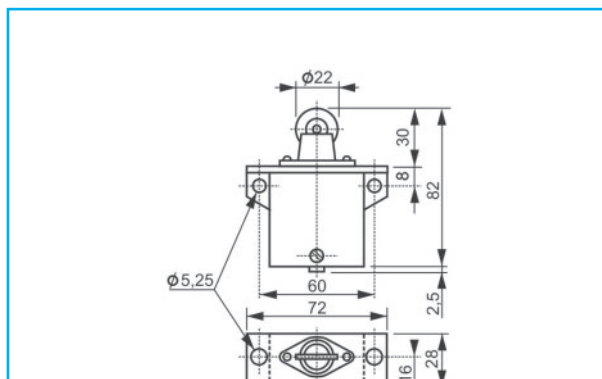
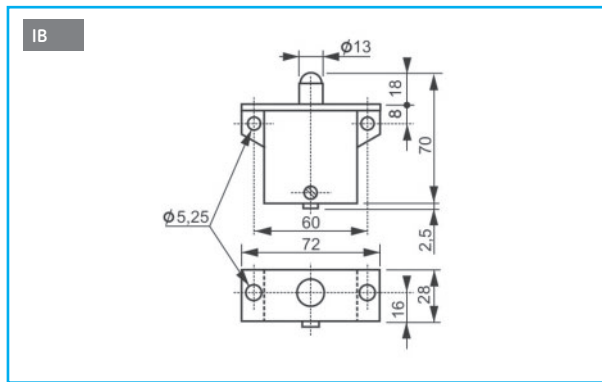
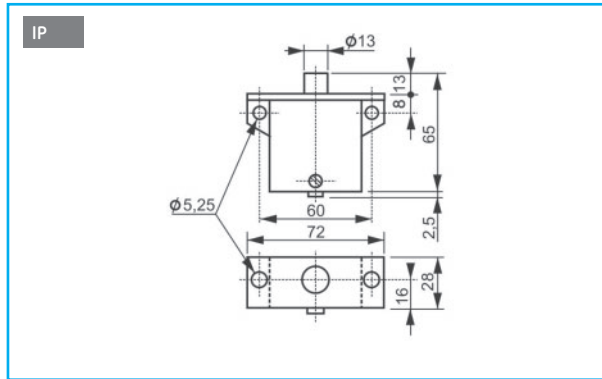

Angle

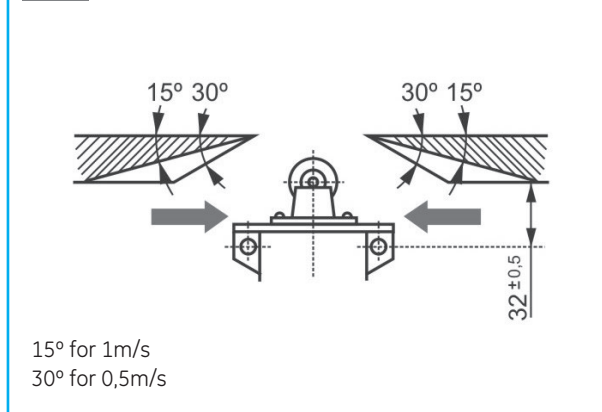

Three pole limit-switches Series 114FCT

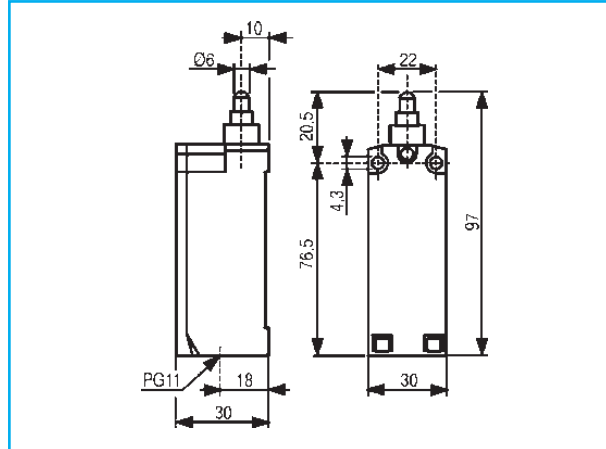

Dimensions

Intro

A

B

C

D

E

F

G

H

I

J/X



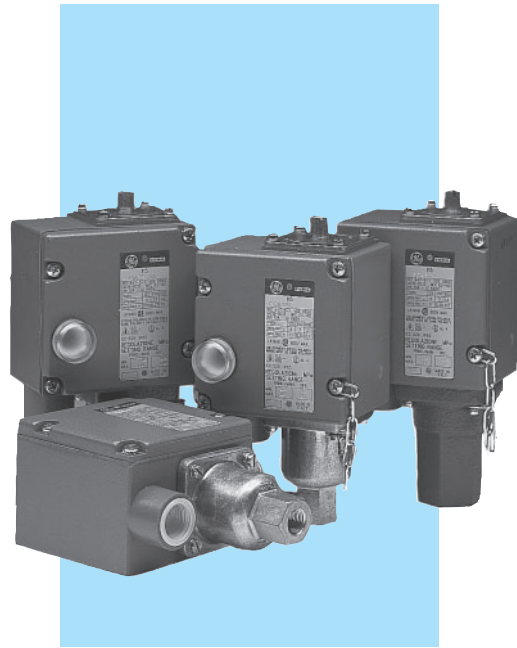

### Standards

IEC/EN 60947-5-1 BSI  
CEI UTE  
VDE 0660

### Approvals



ASE/SEV (Switzerland)

### Pressure switches

- Controlled fluid temperature: 120°C
- Fluids that can be controlled by bellows pressure switches: air and rare gases, freon, water (sea-water not included), fuel oils, mineral oils, hydraulic oils and other kinds of fluids that do not corrode steel, tin and other kinds of fluids that do not corrode steel, tin and copper alloys. To avoid absolutely and solvents and acids.
- Fluids that can be controlled by piston pressure switches: mineral oils and hydraulic oils that do not corrode steel and cast iron.
- Synthetic oils with base of phosphates, gas and all the other fluids have to be excluded.

### Setting range choice

On the following pages are shown the values within which it is possible to make setting of our pressures switches.

For a correct interpretation, consider that:

- The main setting range defines the values within which it is possible to set the tripping of the pressure switch, when the pressure is decreasing.
- The differential setting range defines the values that, added to those ones of the main range, determine the tripping when pressure is increasing.
- The maximum admissible pressure defines the limit that the devices can stand without consequences. Indicated values have never to exceed also in the case of occasional overpressure of temporary type.

When choosing the most suitable type, consider that the device reaches its excellent efficiency when the tripping point, with decreasing pressure, is set between 25% and 75% of the main setting range.

### Setting

- To completely loose the external screw of the main range and the internal pawl of the differential range.
- By a manometer, to set pressure at the value on which the tripping is wanted, when pressure is decreasing. To screw the external screw of the main range until the tripping of the microswitch (A contact shall result open and B closed).
- To completely screw the pawl of the differential range, until its maximum value.
- To set pressure at the value on which the tripping is wanted, when pressure is increasing.
- To loosen the pawl of the differential range until the tripping of the microswitch (A contact shall result closed and B open).

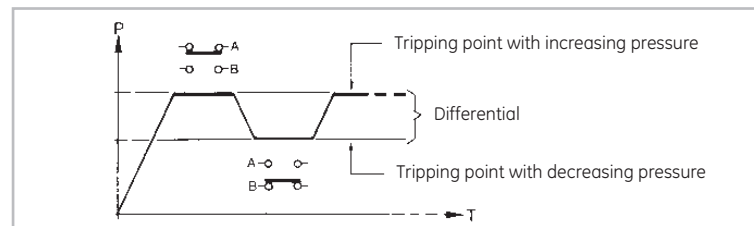



**Location**

Generally the location of our pressure switches can be effected as wanted. Nevertheless, as to the piston types whitout seal ring, location have to be made in such a way as to allow the discharge, through the drainage hole, of the blow-by oil between cylinder and piston (a few drops per hour). The going-out oil can be collected by a proper drainage pipe that conveys it, free falling, into the tank of the hydraulic central, as shown in the below figure.

**Caution**

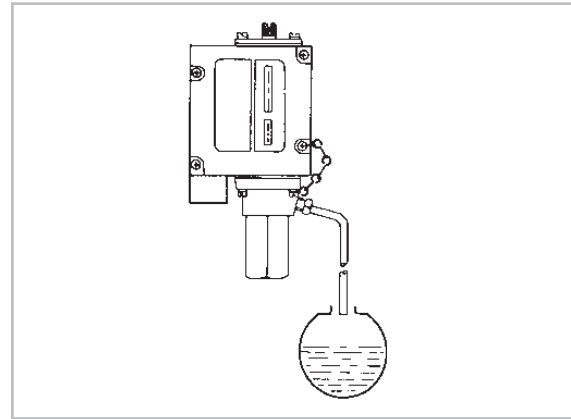

- Do not connect the drainage hole to a return pipe of the line...
- The drainage pipe must not cover a way different from that one indicated (e.g. towards the top).
- Do not plug the drainage holes.

If the above cautions are not met, inside the sensitive group there will be a counter pressure that could damage the sealing washer between actuator and frame of the pressure switch.

**Fixing**

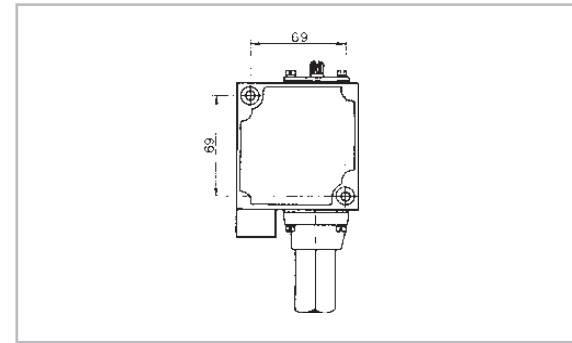

To fix the pressure switch on a proper support, use the two pierceable holes Ø 6.8 mm. located under the cover. To absolutely avoid to fix it directly on the pipe containing the fluid to be controlled, use the threaded pipe fitting for pressure entry.

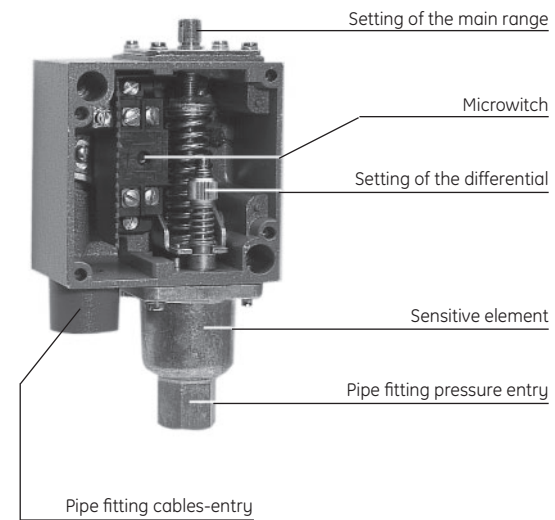

**Pressure switches**

Intro

A

B

C

D

E

F

G

H

I

J/X



Pressure switches - Bellows type

Without lighting signalisation	Setting Range		Maximum admissible pressure Mpa Bar	Weight (kg)	1NO - 1NC		2NO - 2NC		Pack
	Main	Differential			Cat. no.	Ref. no.	Cat. no.	Ref. no.	
	Mpa Bar	Mpa Bar							
	0.002 - 0.15	0.02 - 0.1	0.4	0.950	115PC002	132500			1
	0.02 - 1.5	0.2 - 1	4		115PC002A	215253			1
	0.01 - 0.5	0.04 - 0.1	0.6	0.950	115PC015	132501	115PC2015	132505	1
	0.1 - 5	0.4 - 1	6		115PC015A	215252	115PC2015A	132517	1
	0.01 - 0.8	0.07 - 0.2	1.55	0.950	115PC018	132502	115PC2018	132515	1
	0.1 - 8	0.7 - 2	15.5		115PC018A	241311	115PC2018A	247788	1
	0.1 - 1.9	0.12 - 0.2	2.45	0.950	115PC119	132503			1
	1 - 19	1.2 - 2	24.5		115PC119A	215329			1

Accessories

	Microswitch	Contacts		Weight	Cat. no.	Ref. no.	Pack
		1NO - 1NF	2NO - 2NF				
				0.060	090MI1	130310	25
				0.100	090MI2	130311	25

	Sensitive group	Basic pressure switch	Weight	Bellows type		Piston type						
				Standard	Stainless steel	Without seal ring		With seal ring				
				Cat. no.	Ref. no.	Cat. no.	Ref. no.	Cat. no.	Ref. no.	Pack		
		115PC002	0.045	115807SP	132562	1158065SPA	215320	-	-	-	-	1
		115PC015	0.045	115803SP	132563	1158067SPA	215321	-	-	-	-	1
		115PC018	0.045	115805SP	132564	1158067SPA	215321	-	-	-	-	1
		115PC119	0.045	115804SP	132565	1158067SPA	215321	-	-	-	-	1

	Protective cap of main range screws	Weight	Cat. no.	Ref. no.	Pack
		0.078	115CA	132571	100

Dimensions

Pressure switches - Bellows type

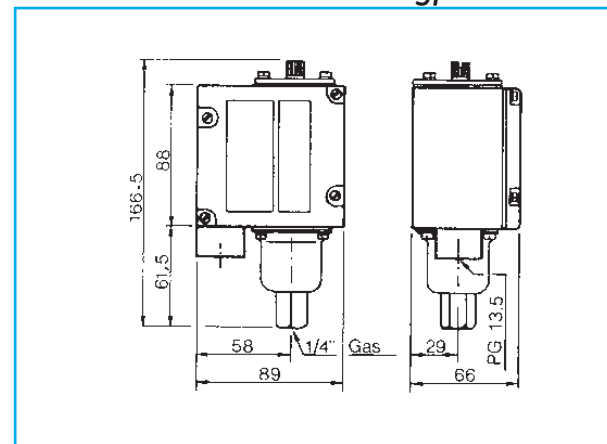

## Technical data

### General

The pressure switches Series 115 are designed for transforming a pressure variation into an electrical signal when a pre-arranged pressure value is reached.

Pressure switches are utilized in the field of the industry machines, installations and transports.

### Climatic protections

Temperature climate	cat. 23/50 (DIN 50014)
Wet climate	cat. 23/83 (DIN 50015)
Hot wet climate	cat. 40/92 (DIN 50015)
Variable wet climate	cat. FW24 (DIN 50016)

### Temperature ranges

Operation	-25°C to +70° C
Storage	-40°C to +70°C

### Insulation class

IP65	IEC/EN 60529
ENCL. 4, 5	CSA

### Vibration resistance

5g at a sinusoidal frequency ranging from to 100 Hz according to IEC 68-2-6	IEC 68-2-6
---	------------

### Mechanical endurance

#### Bellows type

1 million operations. It can be considerably reduced when the pressure jump reaches the maximum value foreseen for every type of device and the operations number is high. The bellows endurance can be also negatively influenced by the temperature and the kind of controlled fluid.

### Rated insulation voltage

600V AC/DC

### Insulation class

Group C according to VDE 0110

### Short-circuit protection

10 A gL fuses according to IEC 947-5-1

### Electrical performances

090MI1 (1NO + 1NC)  
090MI2 (2NO + 2NC)  
Rated thermal current: I<sub>th</sub> = 10 A

#### Performances according IEC 947.5.1

Category AC15 (A600)										
Voltage U <sub>e</sub>	V	24	48	60	110	220	380	500	600	
Current I <sub>e</sub>	A	10	10	10	6	3	2	1.5	1.2	
Category DC 13 (P600)										
Voltage U <sub>e</sub>	V	24	48	60	110	220	300			
Current I <sub>e</sub>	A	2.5	1.4	1	0.55	0.27	0.2			

#### Performances according to CSA

AC/Heavy Duty (A/600)  
DC/Standard Duty (Q300)  
Connections at same polarity

### Connection terminals

Screw type without clamping screw.  
Suitable for eye, fork and hook terminals.

### Cable entry

One PG 13.5 threaded cable entry.

### Range

The pressure switches series 115 are available in two basic versions:

- With bellows sensitive element for pressures ranging between 0.002 Mpa (0.02 bar) minimum and 2.1 Mpa (21 bar) maximum.
- With piston sensitive element for pressures ranging between 0.95 Mpa (9.5 bar) minimum and 37.25 Mpa (372.5 bar) maximum.

Both versions can be supplied:

- Without lighting signaling
- With lighting signaling

### Construction

Snap-action 1NO-1NC or 2NO+2NC microswitches with double-break contacts without positive-break of the NC contact.

Bellows sensitive element, hermetic sealing, made by Tombacco (or stainless steel) material enclosed into a die-cast zamac case complete with a 1 mm. damper. Piston sensitive element, with or without seal ring, with steel piston enclosed into a cast-iron cylinder complete with 1 mm. damper.

Enclosure and cover are made of die-cast aluminium and painted with anaphoresis process grey RAL 7012..

Pressure switches

Intro

A

B

C

D

E

F

G

H

I

J/X





**H.2 VAT20 - Micro AC variable speed drives**

H.3 Order codes

H.5 I/O terminal board specifications

H.5 I/O wiring

H.6 Dimensions and weights

Intro

**H.8 VAT200 - Mini AC variable speed drives**

H.9 Order codes

**POWER DEVICES**

Contactors and overload relays

A

H.10 Technical data

Auxiliary relays and contactors

B

H.12 I/O Power & control layout

H.12 I/O Control terminal description

H.13 External accessories

Motor protection devices

C

H.14 EMC compliance

H.15 Dimensions

Applications

D

Main switches

E

**H.18 AF6-drives**

H.18 Introduction

**AUXILIARY DEVICES**

Control and signalling units

F

H.24 AF-60 LP - Micro Drives

H.32 AF-650 GP - General Purpose Drives

H.52 AF-600 FP - Fan and Pump Drives

Electronic relays

G

**POWER ELECTRONICS**

**Speed drive units**

H

Soft starters

I

Lighting dimmer-stabilizer/Numerical index

J/X



H.1



**Micro AC variable speed drives**

- Single-phase or three-phase digital inverters for controlling the speed of three-phase induction AC motors from 0.2 to 2.2kW
- Built-in keypad and display
- IP20 or IP65 protection degree
- Built-in EMC filter for industrial environment (class A)
- DIN rail mountable by optional kit
- Global standards CE and cUL



**Technical data**

**Control specifications**

Control system	Sinusoidal wave PWM inverter
Output frequency	0 - 200Hz
Voltage / Frequency	Constant torque, Constant power, Torque boost
	Six selectable pre-set patterns
Overload capacity	150%, 60 sec.
Carrier frequency	Selectable 4 - 16kHz
Frequency setting resolution	
Digital	0.1Hz(0-99.9Hz), 1Hz(100-200Hz)
Analogic	0.1Hz/ 60Hz
Acceleration/deceleration	0.1 - 999 sec.
	Acceleration and deceleration set individually
Operating system	Two mode selection: forward run by FWD input, Reverse run by REV input Run by FWD input, forward/reverse command by REV input
Stopping system	Selectable either ramp down or coast to stop
DC braking	DC brake starting frequency 1-10Hz DC braking level 0-20%, DC braking time 0-25.5s
Frequency limit	Upper limit (1-200Hz), lower limit (0-200Hz)
Other functions	Auto re-start, Auto reset, Flying start, Jog Slow speeds

**I/O configuration**

Operation panel	3 digits, 7 segment display with 5 operation keys
Sequence input	Four digital inputs (2 are programmable)
Sequence output	One programmable relay output
Frequency setting input	One analogue either 0-10V, 4-20mA or 0-20mA configurable
Source for potentiometer	10VDC source for 2-10kΩ potentiometer
Analogue outputs	0-10VDC for frequency output display

**Protection features**







Prevention	Overcurrent limitation, Overvoltage limitation, Stall prevention
Trip	Overload, Overvoltage, Undervoltage, Overcurrent, Powerloss, Output short-circuit, Grounding fault, Overtemperature
Fault history	The last three faults are recorded

**Operating environment**

Installation	Indoor, with atmosphere free from corrosive or explosive gases, dust, steam or oil mist.
Protection degree	IP20 and IP65
Temperature range	from -10 to 50 °C
Relative humidity	0-95% without condensation
Vibrations	Under 1G (9.8 m/s <sup>2</sup> )
Standards	cUL, CE



1 and 3 phase speed drives

Input voltage + 10%, -15%, 50/60 Hz (± 5%)		Input power	Output current	Max. motor power kW (1)	Cooling convection	Losses	Protection degree	Cat. no.	Ref. no.	Pack
	1ph 200V - 240V	0.53	1.4	0.2	natural	21	IP20	U20N0K2S	167075	1
		0.88	2.3	0.4	forced	38	IP20	U20N0K4S	167076	1
		1.6	4.2	0.75	forced	60	IP20	U20N0K7S	167077	1
	1ph / 3ph 200V - 240V	2.9	7.5	1.5	forced	103	IP20	U20N1K5S (2)	167078	1
		4.0	10.5	2.2	forced	149	IP20	U20N2K2S (2)	167079	1
	3ph 380V - 480V	1.6	2.3	0.75	forced	61	IP20	U20X0K7S (2)	167080	1
2.9		3.8	1.5	forced	79	IP20	U20X1K5S (2)	167081	1	
4.0		5.2	2.2	forced	94	IP20	U20X2K2S (2)	167082	1	
	1ph 200V - 240V	0.53	1.4	0.2	natural	21	IP65	U20N0K2P (3)	167088	1
		0.88	2.3	0.4	natural	38	IP65	U20N0K4P (3)	167089	1
		1.6	4.2	0.75	natural	60	IP65	U20N0K7P (3)	167090	1
	1ph / 3ph 200V - 240V	0.53	1.4	0.2	natural	21	IP65	U20N0K2PS (4)	167132	1
		0.88	2.3	0.4	natural	38	IP65	U20N0K4PS (4)	167133	1
	3ph 380V - 480V	1.6	2.3	0.75	natural	60	IP65	U20N0K7PS (4)	167134	1
2.9		7.5	1.5	natural	103	IP65	U20N1K5P (3)	167091	1	
4.0		10.5	2.2	natural	149	IP65	U20N2K2P (3)	167092	1	
	1ph / 3ph 200V - 240V	2.9	7.5	1.5	natural	103	IP65	U20N1K5PS (4)	167135	1
		4.0	10.5	2.2	natural	149	IP65	U20N2K2PS (4)	167136	1
	3ph 380V - 480V	1.6	2.3	0.75	natural	61	IP65	U20X0K7P (3)	167093	1
2.9		3.8	1.5	natural	79	IP65	U20X1K5P (3)	167094	1	
4.0		5.2	2.2	natural	94	IP65	U20X2K2P (3)	167095	1	
	1ph / 3ph 200V - 240V	1.6	2.3	0.75	natural	61	IP65	U20X0K7PS (4)	167137	1
		2.9	3.8	1.5	natural	79	IP65	U20X1K5PS (4)	167138	1
	3ph 380V - 480V	4.0	5.2	2.2	natural	94	IP65	U20X2K2PS (4)	167139	1

(1) Ratings for standard three-pole induction motors with four poles.  
 (2) Units including dynamic braking function. An external braking resistor is needed to perform operation.  
 (3) IP65 models type U20\_ \_ P include only keypad in the front cover.  
 (4) IP65 models type U20\_ \_ PS include power switch, forward/reverse switch and potentiometer in the front cover.

Micro AC speed drives

Intro

A

B

C

D

E

F

G

H

I

J/X



Options and accessories

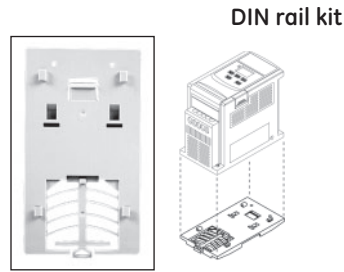

DIN rail kit

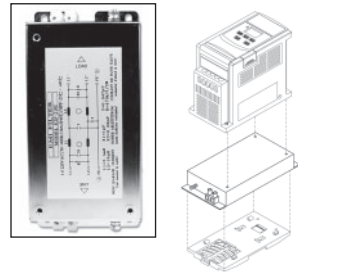

EMC filters

VAT 20 includes as standard a Class A EMC filter, for industrial environment. For residential environment, the use of external Class B EMC foot print filter is recommended.

Cat. No.	A	B	C	D	E
U20AF0K7	156	76	25	60	145
U20AF2K2	170	221	38	108	156
U20AF2K2X	170	221	38	108	156

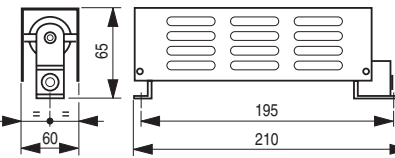
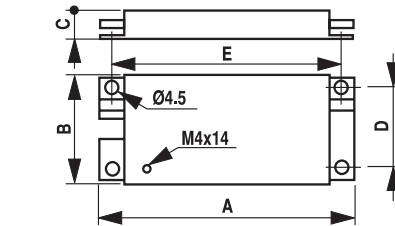

Fig. 4

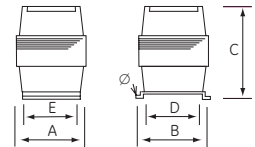
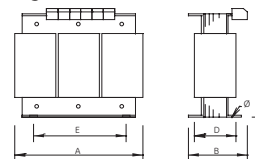

Fig. 1



	Motor (kW)	Applicable to drive	Cat. no.	Ref. no.	Pack
Braking resistors 100% braking torque, 10% ED	1.5	U20N1K5	TLR100P200	108223	1
	2.2	U20N2K2	TLR75P200	116300	1
	0.75	U20X0K7	TLR750P200	116301	1
	1.5	U20X1K5	TLR400P200	116302	1
	2.2	U20X2K2	TLR250P200	108227	1

	Losses (W)	Applicable to drive	Cat. no.	Ref. no.	Pack
Reactors Input reactors for single phase drives	2.5	U20N0K2S	ACRP3A7H0	168490	1
	5	U20N0K4S	ACRP8A2H5	168491	1
	7	U20N0K7S	ACRP12A2H5	168492	1
	7.5	U20N1K5S	ACRP18A1H3	168493	1
	8	U20N2K2S	ACRP22A0H84	168494	1
	Input reactors for three phase drives	11	U20N1K5S	ACRP6A2H5	168496
14		U20N2K2S	ACRP9A1H3	168497	1
8		U20X0K7S	ACRP3A8H1	168509	1
9		U20X1K5S	ACRP4A5H1	168510	1
11		U20X2K2S	ACRP6A3H4	168511	1

Cat.No.	Losses W	Fig.	A	B	C	D	E	Ø	Weight (kg)
ACRP3A7H0	2.4	4	75	96	85	80	56	6	1.3
ACRP8A2H5	5.2	4	75	96	100	80	56	6	1.8
ACRP12A2H5	6.8	4	84	102	110	86	65	6	2.7
ACRP18A1H3	7.3	4	96	112	106	96	77	6	3.2
ACRP22A0H84	8	4	96	112	116	96	77	6	3.7
ACRP6A2H5	17	1	120	80	152	41	100	6	1.5
ACRP9A1H3	18	1	120	80	152	41	100	6	1.6
ACRP3A8H1	17	1	120	80	152	41	100	6	1.4
ACRP4A5H1	16	1	120	80	152	41	100	6	1.5
ACRP6A3H4	19	1	120	80	152	41	100	6	1.7

Dimensions in mm



## I/O terminal board specifications

### Digital inputs

Symbol	Description	Function
12V	Common digital inputs	12V DC supply for all digital inputs
FWD	Forward run	Used for forward run command
REV	Reverse run	Used for reverse run command
SP1	Multifunction input	This is a programmable digital input Either jog, slow speed, emergency stop, output shut off or reset function are allowed
RST	Fault reset	This is a programmable input set to reset function as default Either jog, slow speed, emergency and output shut off are allowed as well

### Digital outputs

Trip relay	Multifunction output	This is a programmable output relay set to fault function as default
1, 2		Run status and frequency reached are allowed as well

### Analogue inputs

MVI	Frequency setting	Programmable analogue frequency signal input 0-10V, 4-20mA or 0-20mA allowed
0V	Common analogue I/O	

### Analogue outputs

FM	Frequency output	Analogue output 0-10V. May be used as speed meter
0V	Common analogue I/O	

### Other

+10V	10V DC source	10V DC power supply for potentiometer 2-10kΩ (2W)
------	---------------	---

### I/O wiring

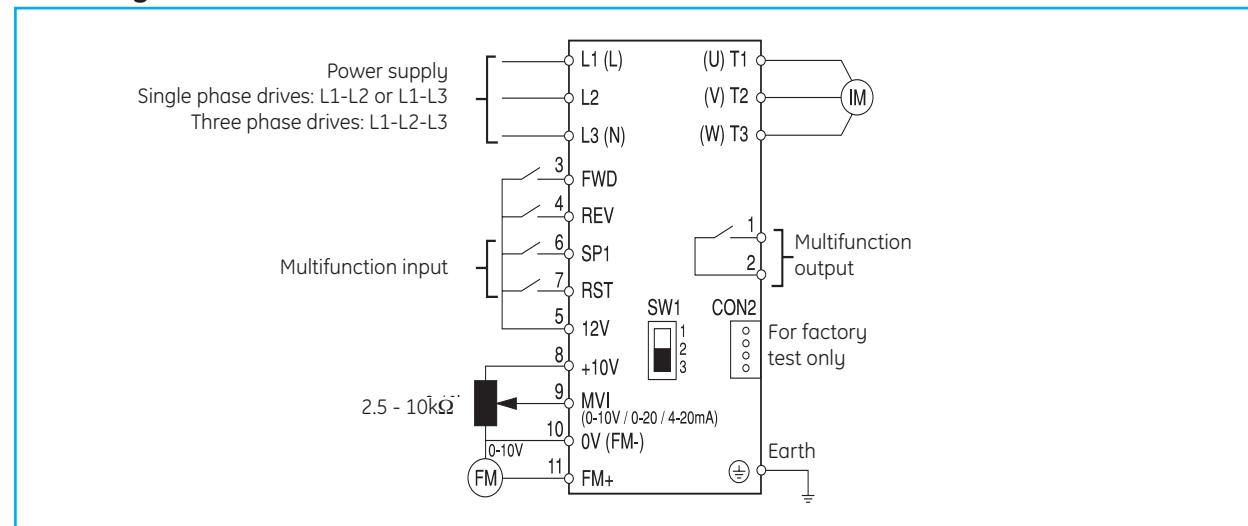

Micro AC speed drives

Intro

A

B

C

D

E

F

G

H

I

J/X





Dimensional drawings

Protection IP20

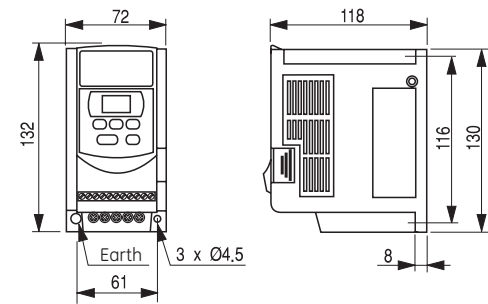

Cat. no.	Ref. no.	Weight (kg)
U20N0K2S	167075	0.76
U20N0K4S	167076	0.77
U20N0K7S	167077	0.8

Dimensions in mm

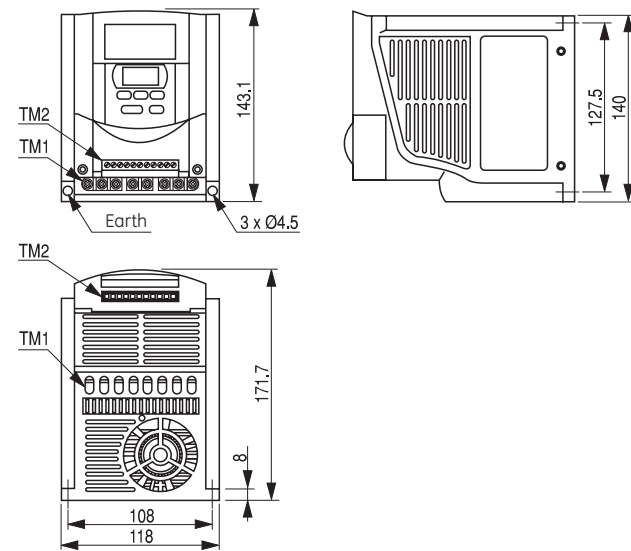

Cat. no.	Ref. no.	Weight (kg)
U20N1K5S	167078	1.66
U20N2K2S	167079	1.76
U20X0K7S	167080	1.60
U20X1K5S	167081	1.60
U20X2K2S	167082	1.63

Dimensions in mm



Protection IP65

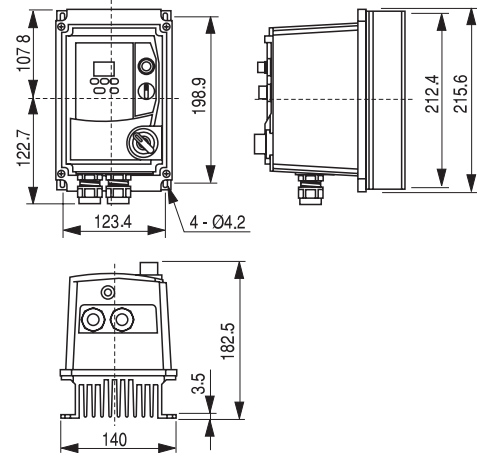

Cat. no.	Ref. no.	Weight (kg)
U20N0K2P	167088	2.9
U20N0K4P	167089	2.9
U20N0K7P	167090	2.9
U20N0K2PS	167132	2.9
U20N0K4PS	167133	2.9
U20N0K7PS	167134	2.9

Dimensions in mm

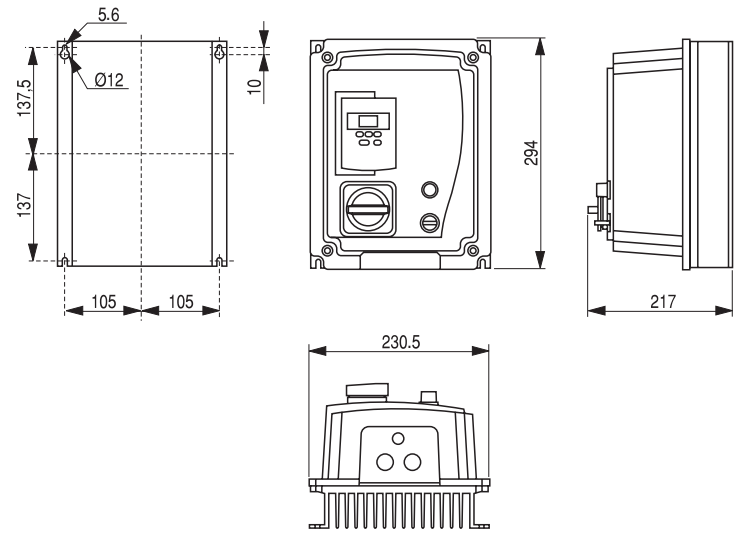

Cat. no.	Ref. no.	Weight (kg)
U20N1K5P	167091	4.8
U20N2K2P	167092	4.9
U20X0K7P	167093	4.9
U20X1K5P	167094	4.9
U20X2K2P	167095	4.9
U20N1K5PS	167135	5.2
U20N2K2PS	167136	5.3
U20X0K7PS	167137	5.2
U20X1K5PS	167138	5.2
U20X2K2PS	167139	5.2

Dimensions in mm

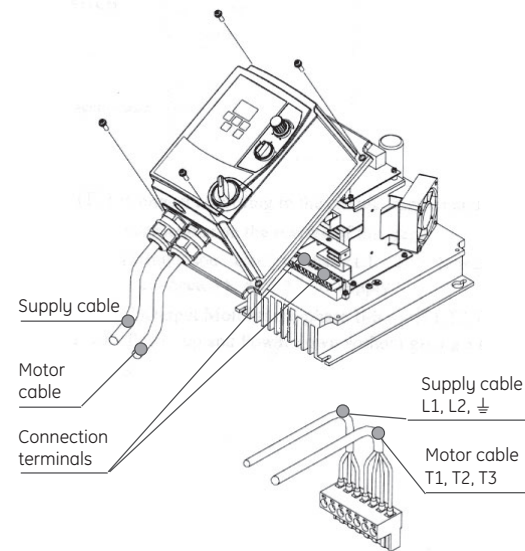

Micro AC speed drives

Intro

A

B

C

D

E

F

G

H

I

J/X





### Mini AC variable speed drives

The VAT200 is a well performed, sensorless vector VSD for AC standard motors available in the following ranges:

- From 0.4 to 2.2 kW at 200V, single phase power supply
- From 0.4 to 7.5 kW at 200V, three phase power supply
- From 0.75 to 55 kW at 400V, three phase power supply

### Advantages

- Compact size
- Built-in removable LED keypad
- Optional multilanguage LCD keypad
- Sensorless vector control or V/f control, selectable
- Built-in with ModBus RTU communications
- Optional Field bus communication DeviceNet, ProfibusDP
- Integrated EMC filters for U20...FS series
- Built-in with dynamic braking up to 15kW
- Performed with simple PLC and PID functions
- Easy start-up & tuning by PC or keypad
- Advanced programming and drive control by built-in PLC function
- Easy maintenance





### Approvals

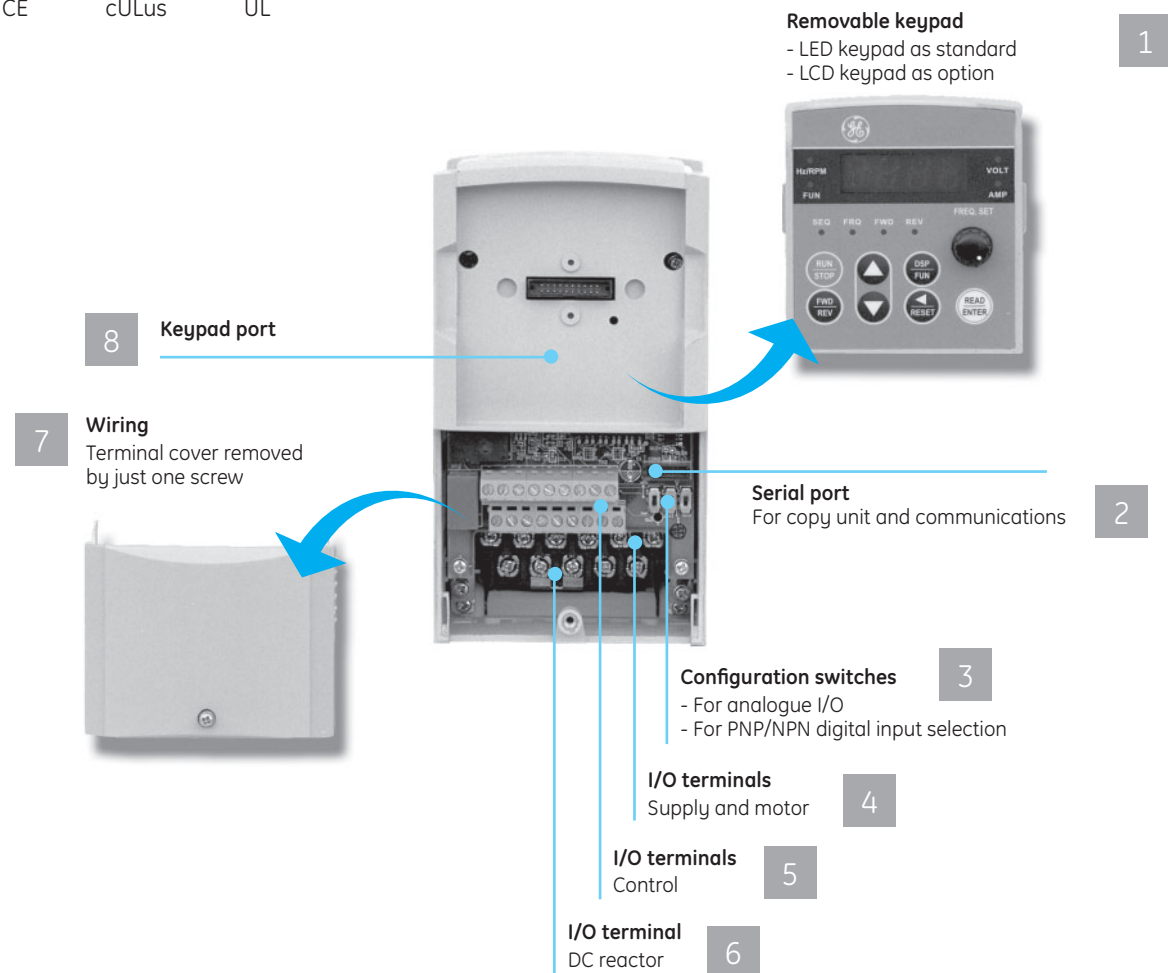



### Simple and reliable



1 and 3 phase speed drives

Input voltage + 10%, -15%, 50/60 Hz (± 5%)	Suitable motor capacity (kW)	Rated output de current (A)	Rated capacity (KVA)	Frame	Cat. no.	Ref. no.	Pack.		
 Frame 1   Frame 2   Frame 3   Frame 4	1ph 200V - 240V	<i>With EMC filter</i>							
		0.4	3.1	1.2	1	U201N00K4FS	167400	1	
		0.75	4.5	1.7	1	U201N00K7FS	167401	1	
		1.5	7.5	2.9	2	U201N01K5FS	167402	1	
		2.2	10.5	4.0	2	U201N02K2FS	167403	1	
		<i>Without EMC filter</i>							
	1ph 200V - 240V	0.4	3.1	1.2	1	U201N00K4SS	167411	1	
		0.75	4.5	1.7	1	U201N00K7SS	167412	1	
		1.5	7.5	2.9	2	U201N01K5SS	167413	1	
		2.2	10.5	4.0	2	U201N02K2SS	167414	1	
	3ph 200V - 240V	<i>Without EMC filter</i>							
		0.4	3.1	1.2	1	U203N00K4SS	167415	1	
		0.75	4.5	1.7	1	U203N00K7SS	167416	1	
		1.5	7.5	2.9	1	U203N01K5SS	167417	1	
2.2		10.5	4	2	U203N02K2SS	167418	1		
3.7		17.5	6.7	2	U203N04K0SS	167419	1		
5.5		26	9.9	3	U203N05K5SS	167420	1		
7.5		35	13.3	3	U203N07K5SS	167422	1		
<i>With EMC filter</i>									
3ph 380V - 480V		0.75	2.3	1.7	1	U203X00K7FS	167404	1	
	1.5	3.8	2.9	1	U203X01K5FS	167405	1		
	2.2	5.2	4	2	U203X02K2FS	167406	1		
	3.7	8.8	6.7	2	U203X04K0FS	167407	1		
	5.5	13	9.9	3	U203X05K5FS	167408	1		
	7.5	17.5	13.3	3	U203X07K5FS	167409	1		
	11	25	19.1	3	U203X11K0FS	167410	1		
	<i>Without EMC filter</i>								
	3ph 380V - 480V	0.75	2.3	1.7	1	U203X00K7SS	167424	1	
		1.5	3.8	2.9	1	U203X01K5SS	167425	1	
2.2		5.2	4	2	U203X02K2SS	167426	1		
3.7		8.8	6.7	2	U203X04K0SS	167427	1		
5.5		13	9.9	3	U203X05K5SS	167428	1		
7.5		17.5	13.3	3	U203X07K5SS	167429	1		
11		25	19.1	3	U203X11K0SS	167430	1		
15		32	27.4	4	U203X15K0SS	167481	1		
18.5		40	34	4	U203X18K5SS	167482	1		
22		48	41	4	U203X22K0SS	167483	1		
30		64	54	5	U203X30K0SS	167484	1		
37		80	68	5	U203X37K0SS	167485	1		
45		96	82	6	U203X45K0SS	167486	1		
55		128	110	6	U203X55K0SS	167487	1		

Accessories

Description	Details	Cat. no.	Ref. no.	Pack.	
 U200ARS485 / 167435	External dynamic braking unit				
	Communication interface	Profibus-DP	U200APB	167433	1
		DeviceNet	U200ADN	167434	1
		RS485	U200ARS485	167435	1
		RS232 for PC to drive	U200ARS232	167436	1
 U200ARS232 / 167436	For frame 1 drives	U200AN101	167446	1	
	For frame 2 drives	U200AN102	167447	1	
	For frame 3 drives	U200AN103	167448	1	
Memory pack	Program copy	U200AMP	167437	1	
 U200AMP / 167437	LED <sup>(1)</sup>	U200ALEDK	167438	1	
	LCD multilanguage	U200ALCDK	167439	1	
	Blank cover	U200ABK	167440	1	
Remote wire for keypad	0.5m	U200AW05	167441	1	
	1.0m	U200AW10	167442	1	
	2.0m	U200AW20	167443	1	
	3.0m	U200AW30	167444	1	
	5.0m	U200AW50	167445	1	

(1) All VAT200 include a LED keypad U200ALEDK as standard.

Mini speed drives

Intro

A

B

C

D

E

F

G

H

I

J/X



Technical data

General specifications

	1ph 200-240V (with / without EMC filter)				3ph 200-240V (without EMC filter)						
	U 2 0 1 N _ _ _ _ _ S				U 2 0 3 N _ _ _ _ _ S S						
	00K4	00K7	01K5	02K2	00K4	00K7	01K5	02K2	04K0	05K5	07K5
Motor ratings (HP)	0.5	1	2	3	0.5	1	2	3	5.5	7.5	10
(kW)	0.4	0.75	1.5	2.2	0.4	0.75	1.5	2.2	3.7	5.5	7.5
Rated output current (A)	3.1	4.5	7.5	10.5	3.1	4.5	7.5	10.5	17.5	26	35
Rated capacity (kVA)	1.2	1.7	2.9	4	1.2	1.7	2.9	4	6.7	9.9	13.3
Max. input voltage	Single phase: 200-240V +10 -15%, 50/60Hz ±5%				Three phase: 380-480V, +10 -15%, 50/60Hz ±5%						
Max. output voltage	Three phase: 0 - 240V				Three phase: 0 - 240V						
Input current (A)	8.5	12	19	27	4.5	6.5	11	15.4	20	29	40

	3ph 380-480V (with / without EMC filter)							3ph 380-480V (without EMC filter)						
	U 2 0 3 X _ _ _ _ _ S							U 2 0 3 X _ _ _ _ _ S S						
	00K7	01K5	02K2	04K0	05K5	07K5	11K0	15K0	18K5	22K0	30K0	37K0	45K0	55K0
Motor ratings (HP)	1	2	3	5.5	7.5	10	15	20	25	30	40	50	60	75
(kW)	0.75	1.5	2.2	3.7	5.5	7.5	11	15	18.5	22	30	37	45	55
Rated output current (A)	2.3	3.8	5.2	8.8	13	17.5	25	32	40	48	64	80	96	128
Rated capacity (kVA)	1.7	2.9	4	6.7	9.9	13.3	19.1	27.4	34	41	54	68	82	110
Max. input voltage	Three phase: 380-480V, +10 -15%, 50/60Hz ±5%							Three phase: 380-480V, +10 -15%, 50/60Hz ±5%						
Max. output voltage	Three phase: 0 - 480V							Three phase: 0 - 480V						
Input current (A)	4.2	5.6	7.3	11.6	17	23	31	38	48	56	75	92	112	142

Frequency control

Control mode	V / f or sensorless vector control
Range	0.1 to 650.0Hz
Starting torque	150% / 1Hz (sensorless vector)
Speed control range	1 : 50 (sensorless vector)
Speed control accuracy	±0.5% (sensorless vector)
Setting resolution	Digital: 0.01 Hz Analogue: 0.06Hz / 60Hz (10 bits)
Keypad setting	Set directly by $\Delta$ $\nabla$ keys or by potentiometer on the keypad
Display function	Four digital LED (or 2x16 LCD) and status indicator; display frequency / speed / line speed / DC voltage / output voltage / current / rotation direction / inverter parameter / trouble log / program version
Frequency setting	1. External potentiometer 0-5V / 0-10V / 4-20mA / 5-0V / 10-0V / 20-4mA 2. Performs up/down controls, speed control or automatic procedure control with multifunctional contacts on the terminal block (TM2)
Frequency limit function	Respectively setting upper/lower frequency limits and three-stage skip frequencies

Control

Carrier frequency	2 to 16kHz
V / F pattern	18 fixable patterns, 1 programmable pattern
Acc./Dec. control	Two-stage Acc./Dec. time (0.1 to 3,600 seconds) and two-stage S curve
Multifunctional analog output	5 different functions
Multifunctional input	Assigned to 28 different functions
Multifunctional output	Assigned to 15 different functions
Digital input signal	NPN / PNP toggle
Other functions	Momentary power loss restart, Speed search, Overload detection, Torque detection, 8 preset speeds, Acc./Dec. switch (2 stages), S curve, 3-wire control, PID control, Torque boost, Slip compensation, Frequency upper/lower limit, Auto energy saving, Modbus slave and control link, Abnormal restart, Sequence control, Built-in simple PLC function



**Technical data (continued)**

**Others**

Communication control	Control by RS232 or RS485 One to one or multilink up to 254 stations (RS485 only) Can be set Baud rate, Stop bit and Parity bit
Braking torque	About 100% with braking resistor (20% without braking resistor)
Operation temperature	-10 to +50°C
Storage temperature	-20 to +60°C
Humidity	0 to 95% relative humidity (without condensation)
Vibration	1G (9.8m/S <sup>2</sup> )
EMC	Comply with requirement EN 61800-3 with optional filter
LVD	Comply with requirement EN 50178
Enclosure	IP20 (NEMA 1 by external box attached)
Safety level	UL 508C

**Protective functions**

Overload protection	Inverse characteristic overload protection. Max. 150% inverter current rating / 60 sec.
Fuse protection	The motor stops after FUSE melt
Overvoltage	<b>200V class:</b> DC voltage > 410V <b>400V class:</b> DC voltage > 820V
Undervoltage	<b>200V class:</b> DC voltage < 190V <b>400V class:</b> DC voltage < 380V
Momentary power loss restart	Restart after more than 15ms-power loss possible. Programmed up to 2 sec.
Stall prevention	Stall prevention for Acceleration / Deceleration / Operation
Short-circuit output terminal	Electronic circuit protection
Grounding fault	Electronic circuit protection
Other protections	Heatsink overtemperature, overtorque detection, error contact control, reverse run restriction, restrictions for direct start after power up, error recovery and parameter lock out

Mini speed drives

Intro

A

B

C

D

E

F

G

H

I

J/X

H.11



I/O power and control layout

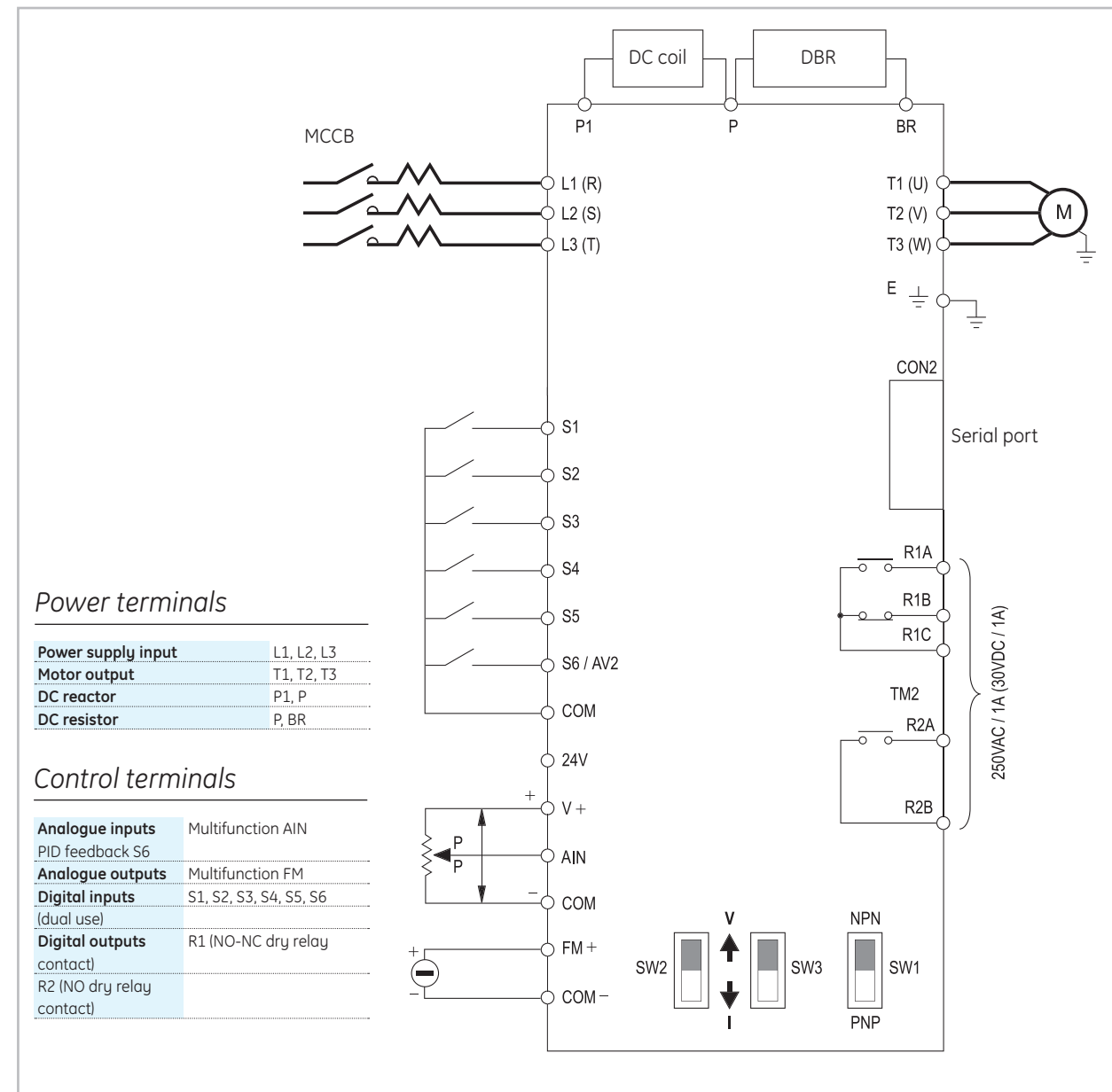

Power terminals

Power supply input	L1, L2, L3
Motor output	T1, T2, T3
DC reactor	P1, P
DC resistor	P, BR

Control terminals

Analogue inputs	Multifunction AIN
PID feedback	S6
Analogue outputs	Multifunction FM
Digital inputs	S1, S2, S3, S4, S5, S6 (dual use)
Digital outputs	R1 (NO-NC dry relay contact)
	R2 (NO dry relay contact)

I/O control terminal description

Symbol	Description
R2A	Multifunctional terminals - Normally Open
R2B	Multifunctional terminals - Normally Open
R1C	Common contact
R1B	Normally Closed contact
R1A	Normally Open contact
10V	Frequency knob (VR) power source terminal
AIN	Analogue frequency signal input terminal
24V	Common source for S1 to S5 in PNP input. Selectable by switch on main PCB
COM	Common terminal for S1 to S5 in NPN input. Selectable by switch on main PCB
FM +	Multifunction analog output, 0-10V DC
S1	Multifunction input terminals
S2	Multifunction input terminals
S3	Multifunction input terminals
S4	Multifunction input terminals
S5	Multifunction input terminals
S6 / AV2	Digital input or PID input terminal (selectable)

Contact rated capacity  
250VAC/1A or 30VDC/1A



External accessories

	VAT200	Losses W	AC reactors	DC reactors	Tubular resistors					
<b>1ph 200-240V</b>	U201N00K4FS	167400	32	ACRP8A2H5	168491	DCR4A5H7	168387	TLR200P200	129165	
	U201N00K7FS	167401	50	ACRP12A2H5	168492	DCR6A3H9	168388	TLR200P200	129165	
	With EMC filter	U201N01K5FS	167402	85	ACRP18A1H3	168493	DCR9A2H4	168389	TLR100P200	108223
	U201N02K2FS	167403	157	ACRP22A0H84	168494	DCR12A1H7	168390	TLR75P200	116300	
	U201N00K4SS	167411	28	ACRP8A2H5	168491	DCR4A5H7	168387	TLR200P200	129165	
	Without EMC filter	U201N00K7SS	167412	45	ACRP12A2H5	168492	DCR6A3H9	168388	TLR200P200	129165
	U201N01K5SS	167413	77	ACRP18A1H3	168493	DCR9A2H4	168389	TLR100P200	108223	
	U201N02K2SS	167414	142	ACRP22A0H84	168494	DCR12A1H7	168390	TLR75P200	116300	
	<b>3ph 200-240V</b>	U203N00K4SS	167415	28	ACRP4A2H5	168495	DCR4A5H7	168387	TLR200P200	129165
		U203N00K7SS	167416	44	ACRP6A2H5	168496	DCR6A3H9	168388	TLR200P200	129165
Without EMC filter		U203N01K5SS	167417	74	ACRP9A1H3	168497	DCR9A2H4	168389	TLR100P200	108223
U203N02K2SS		167418	140	ACRP12A0H84	168498	DCR12A1H7	168390	TLR75P200	116300	
U203N04K0SS		167419	247	ACRP18A0H56	168499	DCR18A1H0	168391	TLR44P600	129166	
U203N05K5SS		167420	274	ACRP27A0H37	168500	DCRP32A0H78	168542	TLR29P600	129167	
U203N07K5SS		167422	372	ACRP35A0H27	168501	DCRP45A0H55	168543	TLR22P600	129168	
<b>3ph 380-480V</b>		U203X00K7FS	167404	45	ACRP3A8H1	168509	DCR3A15H2	168392	TLR750P200	116301
	With EMC filter	U203X01K5FS	167405	69	ACRP4A5H1	168510	DCR4A9H2	168393	TLR400P200	116302
	U203X02K2FS	167406	137	ACRP6A3H4	168511	DCR6A6H8	168394	TLR240P200	108227	
	U203X04K0FS	167407	231	ACRP10A2H	168512	DCR9A4H0	168395	TLR175P600	129173	
	U203X05K5FS	167408	361	ACRP14A1H4	168513	DCRP18A2H9	168555	TLR118P600	129174	
	U203X07K5FS	167409	446	ACRP18A1H1	168514	DCRP25A2H1	168556	TLR86P600	129175	
	U203X11K0FS	167410	656	ACRP27A0H75	168515	DCRP32A1H6	168557	TLR43P1000	129177	
	Without EMC filter	U203X00K7SS	167424	40	ACRP3A8H1	168509	DCR3A15H2	168392	TLR750P200	116301
	U203X01K5SS	167425	62	ACRP4A5H1	168510	DCR4A9H2	168393	TLR400P200	116302	
	U203X02K2SS	167426	123	ACRP6A3H4	168511	DCR6A6H8	168394	TLR240P200	108227	
	U203X04K0SS	167427	208	ACRP10A2H	168512	DCR9A4H0	168395	TLR175P600	129173	
	U203X05K5SS	167428	325	ACRP14A1H4	168513	DCRP18A2H9	168555	TLR118P600	129174	
	U203X07K5SS	167429	402	ACRP18A1H1	168514	DCRP25A2H1	168556	TLR86P600	129175	
	U203X11K0SS	167430	591	ACRP27A0H75	168515	DCRP32A1H6	168557	TLR43P1000	129177	
	U203X15K0SS	167481	1051	ACRP35A0H58	168516	-	-	TLR43P1000	129177	
	U203X18K0SS <sup>(1)</sup>	167482	1218	ACRP38A0H58	168517	-	-	TLR35P1500	129877	
	U203X22K0SS <sup>(1)</sup>	167483	1449	ACRP45A0H45	168518	-	-	TLR29P1800	129878	
	U203X30K0SS <sup>(1)</sup>	167484	1608	ACRP70A0H29	168519	included	-	TLR22P2500	129879	
	U203X37K0SS <sup>(2)</sup>	167485	1993	ACRP90A0H22	168520	included	-	TLR35P1500 <sup>(3)</sup>	129877	
	U203X45K0SS <sup>(2)</sup>	167486	2270	ACRP115A0H18	168521	included	-	TLR29P1800 <sup>(3)</sup>	129878	
U203X55K0SS <sup>(2)</sup>	167487	2957	ACRP160A0H14	168522	included	-	TLR22P2500 <sup>(3)</sup>	129879		

(1) (2) Drives 18.5kW and above do not built dynamic braking. In case this is needed, use external braking unit U200ABU430.

(2) (3) Dynamic braking for drives 45kW, 55kW may need the use of two sets of braking units U200ABU430 in parallel with two sets of braking resistors (one resistor per braking unit).

Mini speed drives

Intro

A

B

C

D

E

F

G

H

I

J/X





**EMC compliance**

Drives with built-in filter type U20....FS, comply with EN 618000-3 second environment.  
 To comply with first environment restricted sector, or to allow EMC compliance to U20....SS drives, an external filter has to be used according following table

		VAT200		Second environment		First environment			
1ph 200-240V	With EMC filter	U201N00K4FS	167400	Not needed		U200F611TA1	167453		
		U201N00K7FS	167401	Not needed		U200F611TA1	167453		
		U201N01K5FS	167402	Not needed		U200F627TA2	167454		
		U201N02K2FS	167403	Not needed		U200F627TA2	167454		
	Without EMC filter	U201N00K4SS	167411	U200F611TA1	167453				
		U201N00K7SS	167412	U200F611TA1	167453				
		U201N01K5SS	167413	U200F627TA2	167454				
		U201N02K2SS	167414	U200F627TA2	167454				
		3ph 200-240V	Without EMC filter	U203N00K4SS	167415	U200F709TA1	167456		
				U203N00K7SS	167416	U200F709TA1	167456		
U203N01K5SS	167417			U200F709TA1	167456				
U203N02K2SS	167418			U200F719TA2	167457				
U203N04K0SS	167419			U200F719TA2	167457				
U203N05K5SS	167420			U200F739TA3	167458				
U203N07K5SS	167422			U200F739TA3	167458				
3ph 380-480V	With EMC filter	U203X00K7FS	167404	Not needed		U200F905TA1	167459		
		U203X01K5FS	167405	Not needed		U200F905TA1	167459		
		U203X02K2FS	167406	Not needed		U200F910TA2	167460		
		U203X04K0FS	167407	Not needed		U200F910TA2	167460		
		U203X05K5FS	167408	Not needed		U200F928TA3	167461		
		U203X07K5FS	167409	Not needed		U200F928TA3	167461		
		U203X11K0FS	167410	Not needed		U200F928TA3	167461		
		Without EMC filter	U203X00K7SS	167424	U200F905TA1	167459			
			U203X01K5SS	167425	U200F905TA1	167459			
			U203X02K2SS	167426	U200F910TA2	167460			
	U203X04K0SS		167427	U200F910TA2	167460				
	U203X05K5SS		167428	U200F928TA3	167461				
	U203X07K5SS		167429	U200F928TA3	167461				
	U203X11K0SS		167430	U200F928TA3	167461				
	U203X15K0SS		167481	U200F34048SMA	167474				
	U203X18K0SS		167482	U200F370A	167475				
	U203X22K0SS		167483	U200F370A	167475				
	U203X30K0SS	167484	U200F3100A	167476					
	U203X37K0SS	167485	U200F3100A	167476					
	U203X45K0SS	167486	U200F3150A	167477					
U203X55K0SS	167487	U200F3180A	167478						

Speed drive units

Intro

A

B

C

D

E

F

G

H

I

J/X



Dimensions

Speed drive

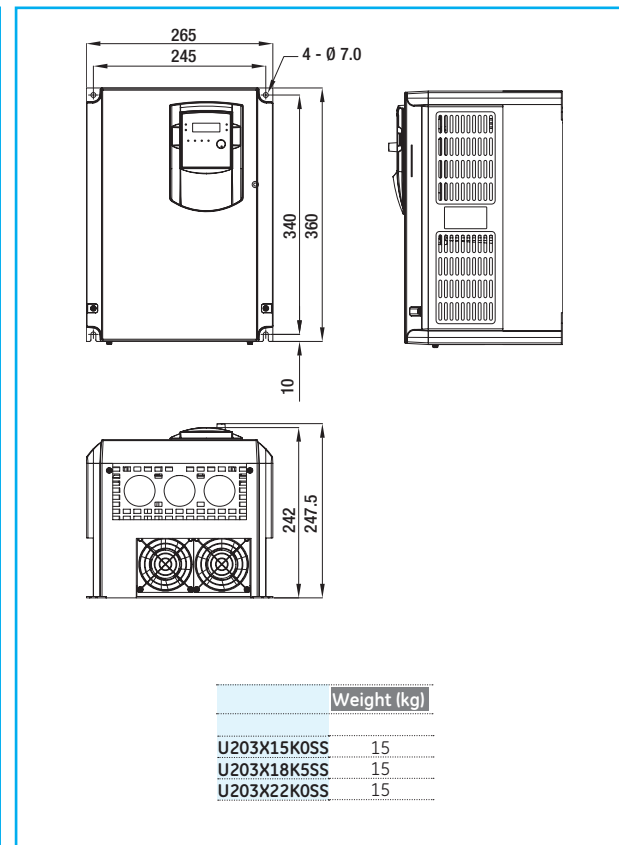
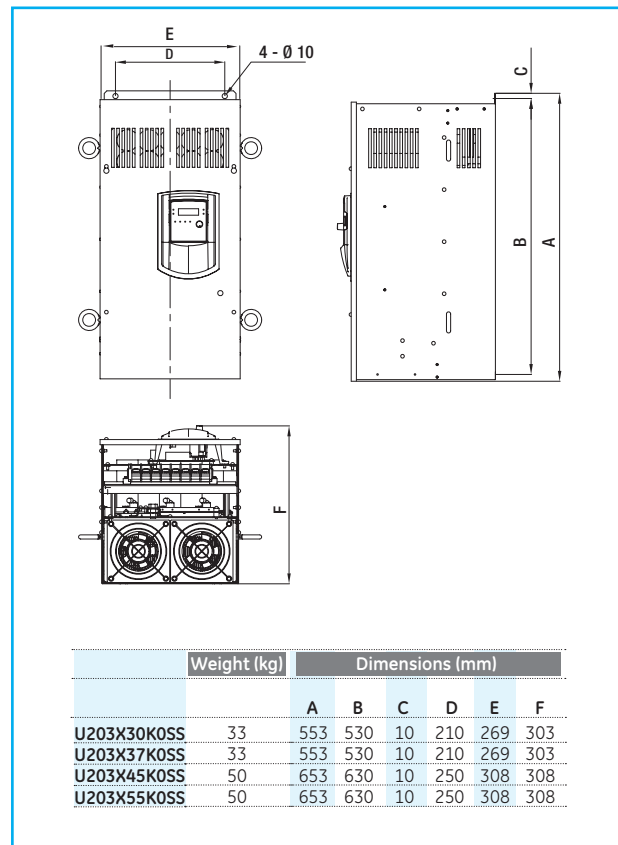
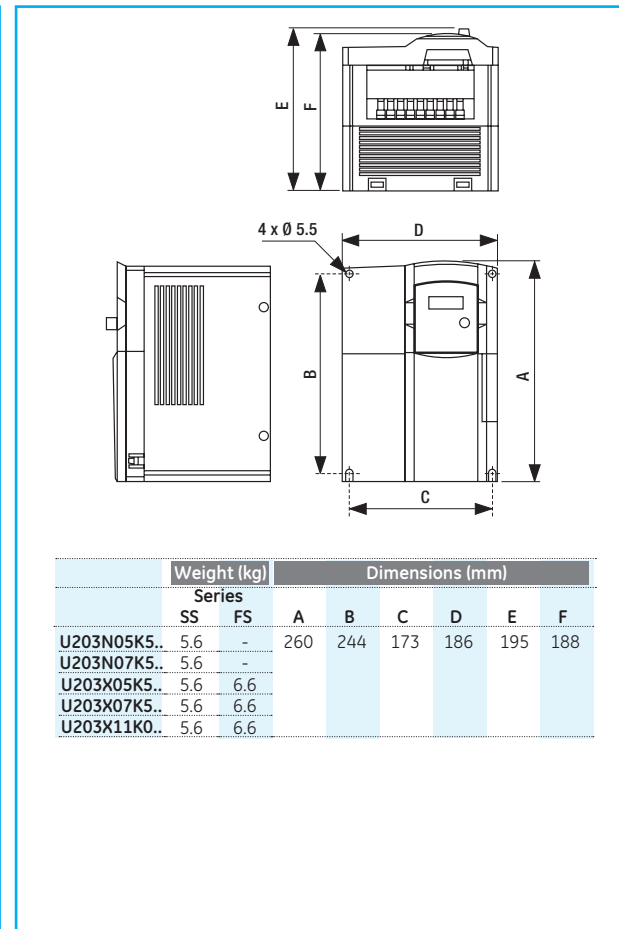
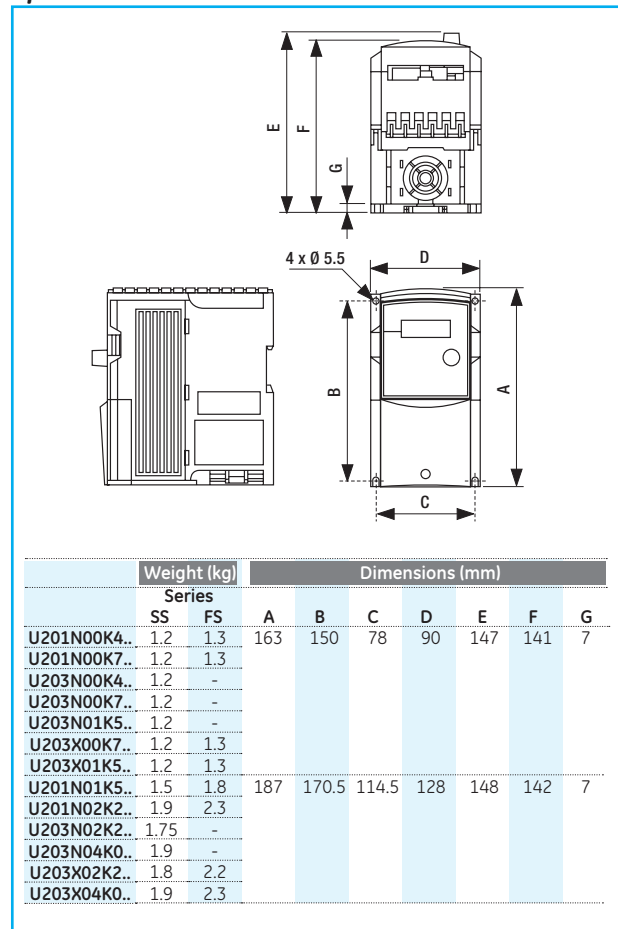

Micro AC speed drives

Intro

A

B

C

D

E

F

G

H

I

J/X



Dimensions (continued)

EMC external filter

		Inverter mounting		External filter size			External filter mount.	
		A	B	C	D	E	F	G
U200F611TA1	167453	78	150	91	192	28	74	181
U200F709TA1	167456							
U200F905TA1	167459							
U200F627TA2	167454	114.5	170.5	128	215	37	111	204
U200F719TA2	167457							
U200F910TA2	167460							
U200F739TA3	167458	173	244	188	289	42	165	278
U200F928TA3	167461							

U200F34048SMA 167474

		Dimensions (mm)						
		W	W1	H	H1	D	d	M
U200F370A	167475	93	79	312	298	190	7	M6
U200F3100A	167476	93	79	312	298	190	7	M6
U200F3150A	167477	126	112	312	298	224	7	M6
U200F3180A	167478	126	112	312	298	224	7	M6

External dynamic braking unit

		Weight (kg)
U200ABU430	167468	2.3



Dimensions (continued)

AC input reactors

Fig. 1

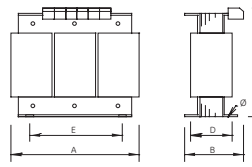

Fig. 3

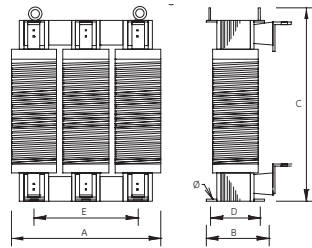
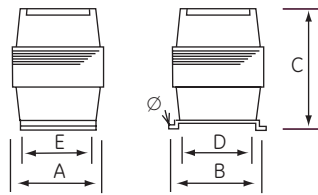

Fig. 4



Cat. No.	Ref.No.	Losses W	Fig.	Dimensions (mm)						Weight (kg)
				A	B	C	D	E	Ø	
ACRP8A2H5	168491	5.2	4	75	96	100	80	56	6	1.8
ACRP12A2H5	168492	6.8	4	84	102	110	86	65	6	2.7
ACRP18A1H3	168493	7.3	4	96	112	106	96	77	6	3.2
ACRP22A0H84	168494	8	4	96	112	116	96	77	6	3.7
ACRP4A2H5	168495	16	1	120	80	152	41	100	6	1.3
ACRP6A2H5	168496	18	1	120	80	152	41	100	6	1.5
ACRP9A1H3	168497	17	1	120	80	152	41	100	6	1.6
ACRP12A0H84	168498	18	1	120	80	152	41	100	6	1.7
ACRP18A0H56	168499	21	1	120	90	152	51	100	6	2.4
ACRP27A0H37	168500	32	1	150	95	183	46	125	6	3.3
ACRP35A0H27	168501	35	1	150	95	183	46	125	6	3.7
ACRP3A8H1	168509	17	1	120	80	152	41	100	6	1.4
ACRP4A5H1	168510	16	1	120	80	152	41	100	6	1.5
ACRP6A3H4	168511	19	1	120	80	152	41	100	6	1.7
ACRP10A2H	168512	23	1	120	90	152	51	100	6	2.5
ACRP14A1H4	168513	29	1	150	95	178	46	125	6	3.2
ACRP18A1H1	168514	35	1	150	95	178	46	125	6	4
ACRP27A0H75	168515	77	1	150	106	233	72	100	9	4.8
ACRP35A0H58	168516	98	1	150	111	233	77	100	9	5.5
ACRP38A0H58	168517	96	1	150	116	233	82	100	9	6.4
ACRP45A0H45	168518	102	1	150	121	233	87	100	9	7.1
ACRP70A0H29	168519	147	1	150	151	250	117	100	9	11
ACRP90A0H22	168520	158	1	180	136	286	102	120	9	13.1
ACRP115A0H18	168521	186	1	180	156	301	122	120	9	16.9
ACRP160A0H14	168522	268	3	240	181	288	107	160	9	25.7

Mini speed drives

Intro

A

B

C

D

E

F

G

H

I

J/X

DC reactors

Fig. 2

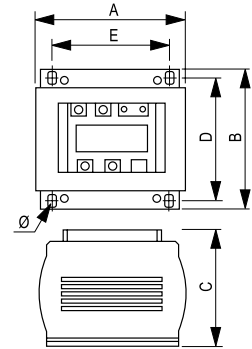
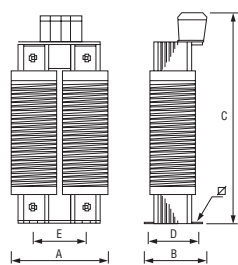

Fig. 5



Cat. No.	Ref.No.	Losses W	Fig.	Dimensions (mm)						Weight (kg)
				A	B	C	D	E	Ø	
DCR4A5H7	168387	4	2	50	97	84	80	34	6	0.78
DCR6A3H9	168388	6	2	50	97	94	80	34	6	0.94
DCR9A2H4	168389	9	2	75	96	95	80	56	6	1.3
DCR12A1H7	168390	15	2	75	96	95	80	56	6	1.3
DCR18A1H0	168391	22	2	75	96	110	80	56	6	1.8
DCR3A15H2	168392	4	2	50	97	94	80	34	6	0.94
DCR4A9H2	168393	4	2	75	96	95	80	56	6	1.3
DCR6A6H8	168394	6	2	75	96	95	80	56	6	1.3
DCR9A4H0	168395	9	2	75	96	95	80	56	6	1.3
DCRP32A0H78	168542	37	5	100	110	173	91	75	6	3.9
DCRP45A0H55	168543	33	5	120	110	203	86	90	6	6.1
DCRP18A2H9	168555	42	5	100	95	178	76	75	6	3.5
DCRP25A2H1	168556	54	5	100	95	183	76	75	6	3.5
DCRP32A1H6	168557	59	5	100	110	183	91	75	6	3.9



## Highlight of benefits

### One family

- Designed for general purpose applications
- For both constant and variable torque applications
- Just one drive series to run an entire production line
- Broad range: 180W to 1.4 MW, 230 V – 690 V

### Designed for lifetime

- Built-in DC chokes increase the lifetime of the capacitors
- Conformal coating available

### Low operating costs

- Low energy consumption – up to 98% efficiency
- Less energy needed for cooling
- Automatic Energy Optimizer (AEO) potentially saves up to 5% energy compared to standard drives
- Low cost of ownership – no periodic maintenance/ replacement cost
- Energy saving up to 40% depending on the application

## Constant torque applications Heavy Duty

Constant torque applications include those where the load does not change significantly with the speed as conveyors, lifting gear and mixers.

A motor block on a conveyor will always weight the same, regardless of whether the conveyor is running at low or high speed.

The torque required to move this motor block is always the same. Although friction and acceleration torques will vary depending on the operating state, the torque requirement for the load remains constant.

The power required by a system of this type is proportional to the torque required and to the speed of the motor.

Savings can be achieved directly if the speed can be reduced at constant load. Adapting the speed of the belt to the quantity of goods to be transported not only enables those goods to be processed without interruption but also leads to a reduction on the energy required.

Even if it is not possible or desirable to adapt the speed, most speed drives will still bring about reductions in energy consumption, since they regulate the motor's output voltage depending on load and as the load rises, it will increase the voltage.

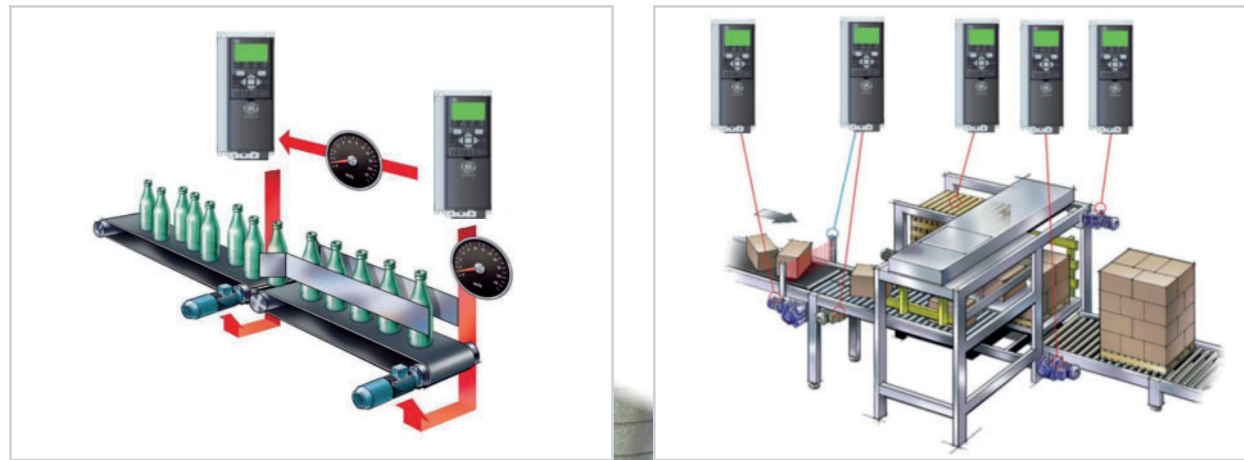

New



## Variable torque applications Light Duty

Often involve pumps and fans. However, a distinction has to be made in the case of pumps. Although the most popular types of centrifugal pump have a quadratic torque characteristic but eccentric, vacuum or positive displacement pumps have a constant torque characteristic. Pumps and fans have a significant share of all power consumed by industrial applications, with consumption levels approximately at 40%. Speed control is a simple yet very effective way of saving energy where fans and pumps with variable load torques are concerned.

Reducing the speed generates a cubic reduction in energy requirements. This significant potential for savings makes all applications with variable torque ideal candidates for the implementation of energy saving. Operators need to take into account that changes in speed alter the operating point and affect the efficiency. If the difference between the maximum power required and average part-load operation is too great, systems should be cascaded. It is often the case that investments pay for themselves relatively quickly when existing systems are converted.

## Built-in class A2 RFI filter

- Drive is ready to use and faults due to incorrect installation or wrong filter selection are avoided
- No over sizing of drive necessary – with motor cables of up to 300m
- Immunity from electrical interference and minimal emission
- Saves panel space and installation costs
- A1 and B1 Filter available as factory option
- Facilitates meeting CE EMC directives (requirement for EU markets)

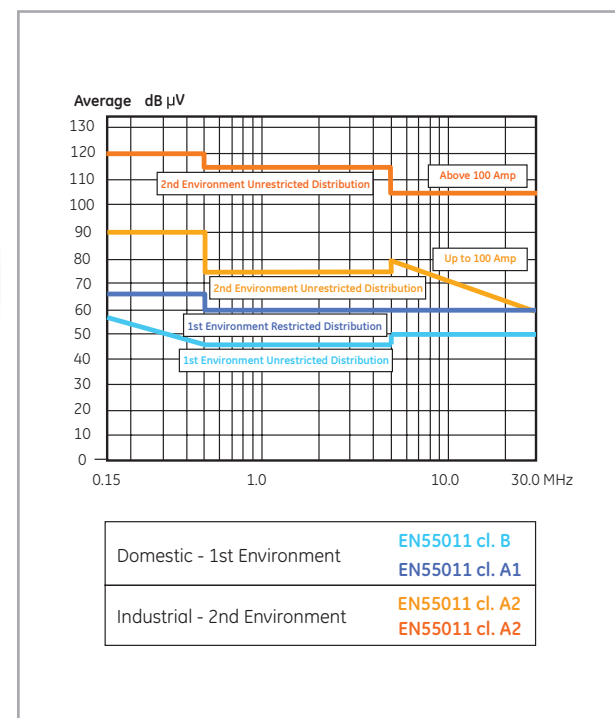

## Built-in DC link reactor

- Low harmonic emission: THDi < 48%
- No voltage drop => full output voltage
- Reduces installation cost
- Fulfils EN 61000-3-2/3-12
- True power factor 0.9

## Reliable operation in harsh environment

- Protection against environmental pollution, aggressive gasses, moisture and dust
- Reduces the probability of failure resulting in less down-time
- Increases the lifetime of the drive
- High protection Class 3C2 **as standard** and increased protection in harsh environments with Class 3C3 **as optional**
- Optional conformal coating is tested to ANSI/ISA S71.04-1985 Class G3 (airborne gasses - harsh) and Class GX (airborne gasses - severe)

## Intelligent heat management

- Cooling fans are easily cleaned without touching the electronics
- 100% cooling air via segregated rear heat-sink- protects the electronic against aggressive environments
- Temperature controlled fan

## High immunity

- Immunity to fluctuating supply voltage (+/- 10%)
- Efficient overvoltage protection
- Fully short-circuit- and earth-leakage proof
- 100kA prospective short-circuit current capability
- No voltage drop and unnecessary de-rating of motor – no external line chokes needed

Benefits

Intro

A

B

C

D

E

F

G

H

I

J/X



New

## AF-600 FP - Special pump functions

### No flow detection

- No flow detection is based on speed and power
- Two sets of data must be programmed into the drive
- Manual or auto set up
- Used to enable sleep mode in closed loop systems for energy savings

### End-of-curve protection

- If there is a water leak in the pipe, it will not produce pressure
- The pump is delivering a large volume of water but cannot maintain the static head
- Drive will go to full flow to try producing pressure (set point)
- The drive running at high speed with a feedback signal less than 97.5% of the set point pressure causes End of Curve action

### Dry pump protection

- Special no-flow condition, where pressure can not be produced, if there is no water
- Drive will go to full speed to try producing full pressure
- Low power consumption at high speed causes Dry Pump action



## PC software tool DCT-10

- One PC tool for all tasks
  - Explorer-like view
  - On and offline commission
  - Help description for each drive parameter
  - Oscilloscope function
  - Option programming
  - Logging of alarms and warnings for improved system performance and documentation
- Interacts with process management  
Communicates through USB, RS485 or Network

## Plug-in option modules

- Tailored for specific application needs
- Low handling cost
- Easy service/ upgrade with a wide range of options
- Field installable Plug n' Play and self configuring



- 1 A slot : Network option modules
- 2 B slot : I/O option modules
- 3 24Vdc External supply option module

## Control wiring and PC connections

- Reduced installation time - Pluggable terminal block for easy installation
- Improved installation quality
- Spring terminals provide better contact than screw terminals
- Thin or thick wires (1.5mm<sup>2</sup> solid/1.0mm<sup>2</sup> stranded wire)

## Built-in control card I/O

### Inputs / Outputs

- 6 digital I/O (0-24 Vdc)
  - 2 configurable as Digital Outputs
  - 2 configurable as Pulse I/O
  - Configurable as PNP or NPN
- 2 form C relay outputs with on/off delays
- 2 analogue Input (10V or 0/4-20mA)
- 1 analogue Output (0/4-20mA)

### Serial ports

- RS 485 Port
  - Supports multi-drop connections
  - Supports 1.2 km cables
  - Switchable network termination
  - Modbus RTU
- USB Port
  - Simple USB direct cable connection ~3m max.
  - Point - to - point

## Network option modules

- Support for all leading protocols
- Easy installation and commissioning
  - Top cable entry -or-
  - Bottom cable entry (if used you cannot add I/O option modules)
- Built-in Networks: Modbus RTU
- Network option modules: Profibus DP, DeviceNet, Ethernet IP, Modbus TCP, Profinet RT
- Additional Option Modules for AF-600 FP: BACnet and LonWorks



Introduction

Intro

A

B

C

D

E

F

G

H

I

J/X



New



**Inquiry customer data for dimensioning of variable speed drives**

**Nominal Motor Data (Type Plate)**

Motor Type :	Manufacturer:		
Nominal Power Pn:	kW		
Nominal Voltage Un (Y/Δ):	V	Nominal Current I <sub>N</sub> (Y/Δ):	A
Nominal Speed:	min <sup>-1</sup>	cos φ	
Specifications:			
<b>Grid Voltage:</b>	Grid Type (IT/TT/TN):		
Length of Motorcable:	Degree of EMC :		
Application Area (Industry / Residential) :			
Special Exigencies:			
<b>Application Description:</b>			
_____			
_____			
_____			
Torque characteristics (Constant/Quadratic):			
Overload (110/160%):			
Speed Range:			
Braking Torque:			
Desired Functionalities:			
_____			
_____			
_____			
Specification:			
_____			
_____			
_____			
<b>Communication System:</b>			
<b>Protection Degree:</b>	IP	Special Ambient Conditions	

**AC drive**

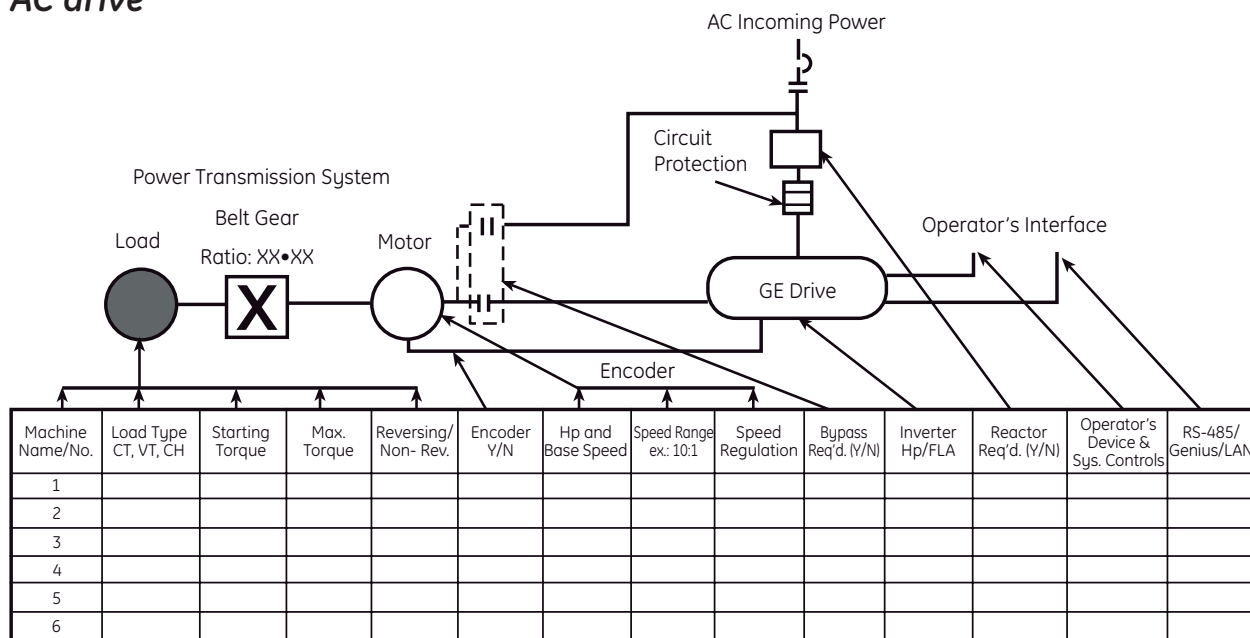

New

## General information: Circuit protection guidelines

For some products, incoming line fuses are required to meet the basic UL listing requirements. Consult AF-6 Series individual drive design guides for fuse recommendations. The NEC defines several types of control circuits and the overcurrent protection required for each type.

### Type enclosures: IP00, IP20, IP21, IP54, IP55 and IP66 - IEC 60529 - ingress protection (IP) codes

First digit	Protection against foreign objects	Second digit	Protection against moisture
0	Not protected	0	Not protected
1	Protected against objects greater than 50 mm	1	Protected against dripping water
2	Protected against objects greater than 12 mm	2	Protected against dripping water when tilted up to 15°
3	Protected against objects greater than 2.5 mm	3	Protected against spraying water
4	Protected against objects greater than 1.0 mm	4	Protected against splashing water
5	Dust protected	5	Protected against water jets
6	Dust tight	6	Protected against heavy seas
-		7	Protection against the effects of immersion
-		8	Protection against submersion

### Type enclosures: NEMA 1, NEMA 4, NEMA 12 - UL50 and CSAC22.2 no. 94-M91

<b>NEMA 1</b>	Enclosures constructed for either indoor or outdoor use to provide a degree of protection to personnel against incidental contact with the enclosed equipment and to provide a degree of protection against falling dirt.
<b>NEMA 4</b>	Enclosures constructed for either indoor or outdoor use to provide a degree of protection to personnel against incidental contact with the enclosed equipment; to provide a degree of protection against falling dirt, rain, sleet, snow, wind-blown dust, splashing water, hose-directed water, and corrosion; and that will be undamaged by external formation of ice on the enclosure.
<b>NEMA 12</b>	Enclosures constructed (without knockouts) for indoor use to provide a degree of protection to personnel against incidental contact with the enclosed equipment; to provide a degree of protection against falling dirt; against circulating dust, lint, fibers, and flyings; and against dripping and light splashing of liquids.

Protection guidelines

Intro

A

B

C

D

E

F

G

H

I

J/X



New



### AF-60 LP - Micro Drives

The Micro Drive AF-60 LP is a compact but powerful and easy to use AC variable frequency drive. The drive is available in its standard configuration that includes built-in Brake chopper for 1.5kW/2HP and above, single-turn potentiometer for speed reference and LCD keypad display that can be remotely mounted.

- Following models are available:
- Single-phase, 230Vac, from 0.18 to 2.2kW, 1/4 to 3HP
  - Three-phase, 230Vac, from 0.25 to 3.7kW, 1/3 to 5HP
  - Three-phase, 400Vac, from 0.37 to 22kW, 1/2 to 30HP

### Features

#### Ready to start from the beginning

- Self-protecting features
- 150% current overload up to 1 minute
- "Pick up" start (catch a spinning motor)
- Potentiometer on keypad
- Keypad is hot pluggable and can be password protected
- RS485 communication, Modbus protocol
- RFI class A1 filter built-in
- Dynamic brake incorporated from 1.5kW
- High level functions, PI for feedback systems, mechanical brake control for lifts
- Easy to use PC software
- Integrated logic control, PLC

#### Built-in durability

- Robust housing (IP20) protects the drive and allows side-by-side mounting
- Conformal coated circuit boards and high quality capacitors maximize uptime
- Intelligent heat management leads to long life

#### Built-in simplicity speeds installation and set-up

- Installation and set-up immediate
- Wiring diagram, template and quick guide
- DIN-rail kit optional, to 2.2kW

### Approvals / Marking



UL, cUL, C-Tick

### Applications

- Fans
- Pumps
- Mixers
- Conveyors
- Material handling
- Industrial machinery, including: agitators, lathes, spinning machines, machine tools, packaging equipment, plastics and woodworking

### Product numbering system diagram

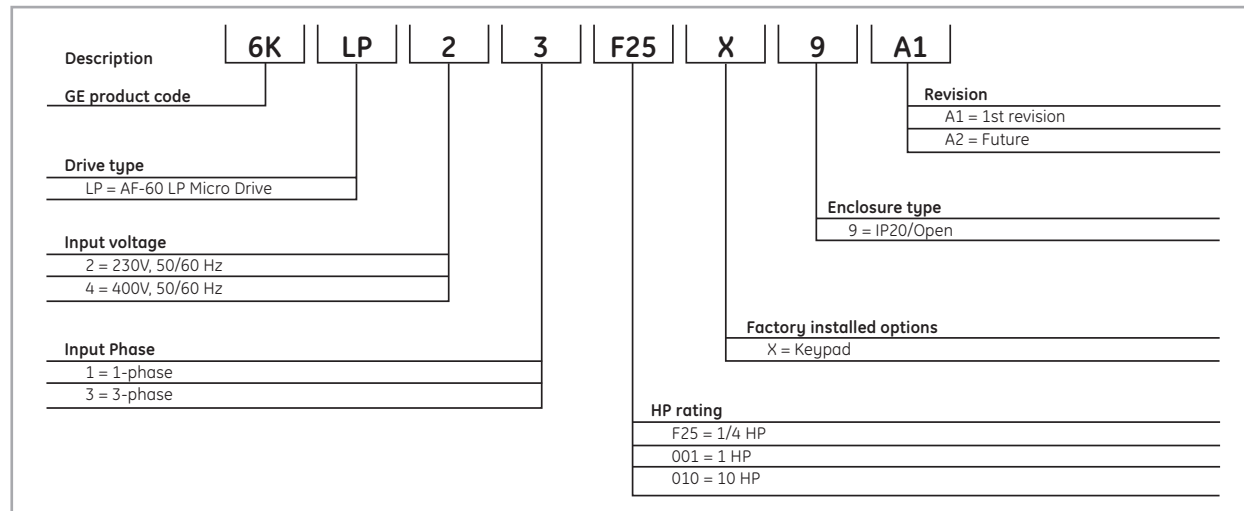

Product number for illustrative purposes only



New

IP20

230 Vac, 1-phase, 50/60 Hz input

Nominal motor ratings			Cat. No.	Ref. No.	Unit Size	Efficiency (%) <sup>(1)</sup>	Losses (W) <sup>(1)</sup>	NEMA 1 kit	DIN-rail mounting kit
Power kW	Power HP	Current A							
0.18	1/4	1.2	6KLP21F25X9A1	404774	M1	94.5	15.5	NEMA1ACL1	RMACL1
0.37	1/2	2.2	6KLP21F50X9A1	404775	M1	95.6	25.0	NEMA1ACL1	RMACL1
0.75	1	4.2	6KLP21001X9A1	404776	M1	96.0	44.0	NEMA1ACL1	RMACL1
1.5	2	6.8	6KLP21002X9A1	404777	M2	96.7	67.0	NEMA1ACL2	RMACL1
2.2	3	9.6	6KLP21003X9A1	404778	M3	97.1	85.1	NEMA1ACL3	N/A

230 Vac, 3-phase, 50/60 Hz input

0.25	1/3	1.5	6KLP23F33X9A1	404779	M1	94.9	20.0	NEMA1ACL1	RMACL1
0.37	1/2	2.2	6KLP23F50X9A1	404780	M1	95.8	24.0	NEMA1ACL1	RMACL1
0.75	1	4.2	6KLP23001X9A1	404781	M1	96.3	39.5	NEMA1ACL1	RMACL1
1.5	2	6.8	6KLP23002X9A1	404782	M2	97.2	57.0	NEMA1ACL2	RMACL1
2.2	3	9.6	6KLP23003X9A1	404783	M3	97.4	77.1	NEMA1ACL3	N/A
3.7	5	15.2	6KLP23005X9A1	404784	M3	97.4	122.8	NEMA1ACL3	N/A

400 Vac, 3-phase, 50/60 Hz input

0.37	1/2	1.2	6KLP43F50X9A1	404785	M1	95.5	25.5	NEMA1ACL1	RMACL1
0.75	1	2.2	6KLP43001X9A1	404786	M1	96.0	43.5	NEMA1ACL1	RMACL1
1.5	2	3.7	6KLP43002X9A1	404787	M2	97.2	56.5	NEMA1ACL2	RMACL1
2.2	3	5.3	6KLP43003X9A1	404788	M2	97.1	81.5	NEMA1ACL2	RMACL1
4	5	9	6KLP43005X9A1	404789	M3	98.0	133.5	NEMA1ACL3	N/A
5.5	7.5	12	6KLP43007X9A1	404790	M3	98.0	166.8	NEMA1ACL3	N/A
7.5	10	15.5	6KLP43010X9A1	404791	M3	98.0	217.5	NEMA1ACL3	N/A
11	15	23	6KLP43015X9A1	404792	M4	97.4	342	NEMA1ACL4	N/A
15	20	31	6KLP43020X9A1	404793	M4	97.4	454	NEMA1ACL4	N/A
18.5	25	37	6KLP43025X9A1	404794	M5	98.0	428	NEMA1ACL5	N/A
22	30	43	6KLP43030X9A1	404795	M5	97.9	520	NEMA1ACL5	N/A

Brake chopper is included with 2HP / 1.5kW drives and above  
 (1) At rated load conditions

Micro Drives

Intro

A

B

C

D

E

F

G

H

I

J/X



New

Options, accessories and replacement parts

**Remote mounting kit for keypad**



Remote mounting kit for mounting keypad on enclosure doors. Kit includes gasket, mounting brackets, and cable. Keypad is rated IP21.

Description	Cat. No.	Ref. No.
Remote mounting kit for keypad	RMKYPDACLP1	404797

**DIN-rail mounting kit**

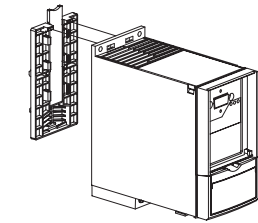

This adapter can be used to mount AF-60 LP Micro Drives at 0.75kW/1HP and below to 35mm DIN-rail.

Description	Cat. No.	Ref. No.
DIN-rail mounting kit for unit size M1 or M2 <sup>(2)</sup>	RMACLP1	404806

(2) Please note that these DIN-rail mounting kits only include bottom cover.

**NEMA 1 kit**

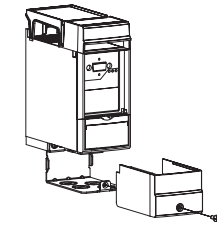

This kit can be mounted to the IP20 protected AF-60 LP Micro Drives to provide NEMA type 1 protection.

Description	Cat. No.	Ref. No.
For 0.75kW/1HP and below drives	NEMA1ACL1	404798
For 1.5kW/2HP at 230V, 2.2kW/3HP at 400V and below drives	NEMA1ACL2	404799
For 2.2kW/3HP at 230V, 3.7kW/5HP at 400V and above drives	NEMA1ACL3	404800
For 11kW/15HP and 15kW/20HP at 400V drives	NEMA1ACL4 <sup>(2)</sup>	404801
For 18.5kW/25HP and 22kW/30HP at 400V drives	NEMA1ACL5 <sup>(2)</sup>	404802

(2) Please note that these NEMA 1 kits only include bottom cover.

**De-coupling plate kit**

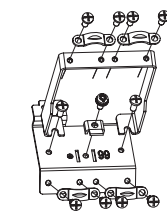

For EMC applications and strain relief for drive wiring.

Description	Cat. No.	Ref. No.
For 1.5kW/2HP at 230V, 2.2kW/3HP at 400V and below drives	DEPLTACLP1	404804
For 2.2kW/3HP at 230V, 3.7kW/5HP at 400V and above drives	DEPLTACLP2	404805
For 11kW/15HP at 400V and above drives	DEPLTACLP3	404803

**Replacement keypad with potentiometer**



LCD keypad with potentiometer for the AF-60 LP Micro Drive. Keypad is removable under power and includes copycat feature to program multiple drives. Includes hand-off-auto keys for local control of drive and large parameter and operational data display. Menu key selects between drive status, quick menu, and main menu. LED indicators for alarms, warnings, and power are also included on each keypad. Keypad dimensions are: 85 H x 65 W x 28 D (with potentiometer) in mm.

Description	Cat. No.	Ref. No.
Replacement AF-60 LP keypad with potentiometer:	KYPDACLP1	404796

AF-6 drives

Intro

A

B

C

D

E

F

G

H

I

J/X



New

Basic wiring diagrams

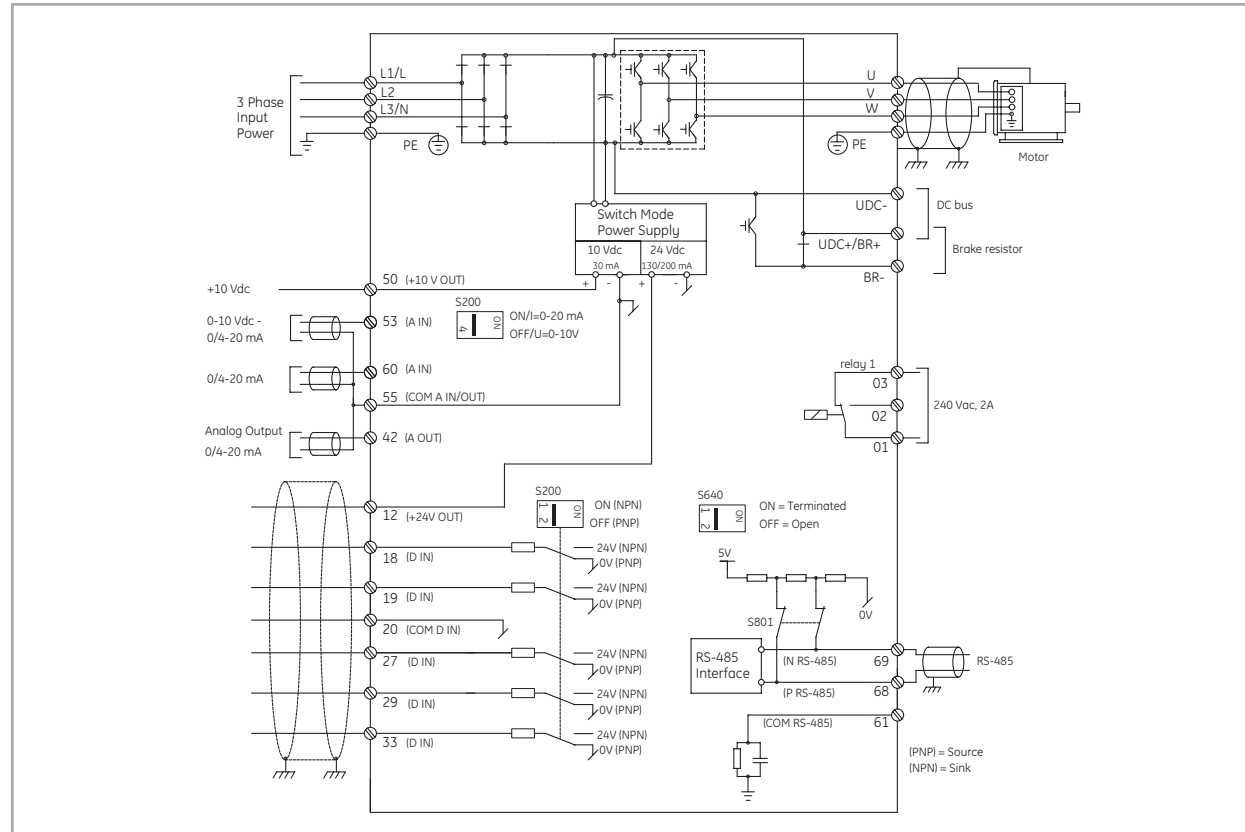

Basic control terminal (PNP configuration and drive factory default settings)

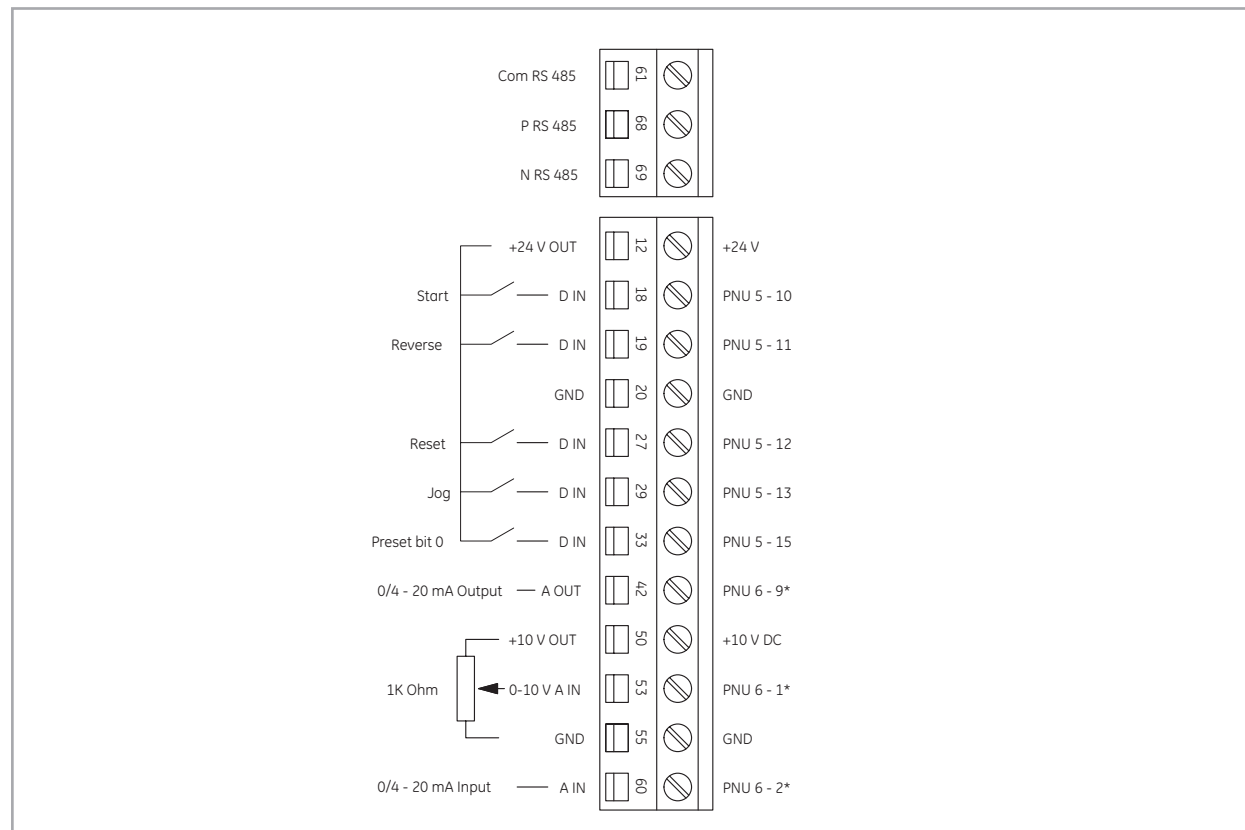

Micro Drives

Intro

A

B

C

D

E

F

G

H

I

J/X



New

Specifications

Environmental conditions

Enclosure	IP20 (NEMA 1 with optional NEMA 1 kit)
Installation location	Do not install in locations where product could be exposed to dust, corrosive gas, inflammable gas, oil mist, vapor, water drops or direct sunlight. There must be no salt in the atmosphere. Condensation must not be caused by sudden changes in temperature. For use at altitudes of 3280 ft. (1000 m) or less without derating.
Ambient temperature	-10° to +50° C
Ambient humidity	5 to 95% RH (non-condensing)
Vibration	1.0 G
Storage temperature	-25° to 65° C

Standards

Approvals	CE, UL, cUL, and C-Tick Suitable for use on a circuit capable of delivering not more than 100,000 rms symmetrical amperes for 230V and 400V. WEEE and RoHS Compliant
-----------	--

Input power supply

Rated input AC voltage	200-240 Vac, 1-phase, 50-60 Hz, +/- 10% V 200-240 Vac, 3-phase, 50-60 Hz, +/- 10% V 380-480 Vac, 3-phase, 50-60 Hz, +/- 10% V
Maximum voltage imbalance	3% of rated supply voltage
True power factor	> 0.4 nominal at rated load
Displacement power factor	> 0.98
Switching on input power supply	Maximum twice/minute
Environment according to EN60664-1	Overvoltage category III/pollution degree 2

Output

Rated output voltage	0-100% of supply voltage
Output frequency	0-200 Hz (Adv. Vector Control Plus Mode), 0-400 Hz (Volts/Hertz Mode)
Switching on output	Unlimited
Accel/decel times	0.05-3600 seconds
Overload current rating	150% of drive rated current for 1 minute

Control

Control method	Sinusoidal PWM Control (V/Hz with torque vector control)
Switching frequency select	2, 4, 8, 12, 16 kHz
Operation method	Keypad operation: Hand, Off, Auto Digital Input: Programmable for Start/Stop, Forward/Reverse, Jog Timer operation: Stop after predetermined time frame Link operation: RS-485 Modbus RTU
Frequency reference setting	Up or Down buttons on keypad or external reference
Analogue input	Built in potentiometer 0-10 Vdc analogue input 4-20 mA analogue input
Preset speeds	8 presets via digital inputs
Link operation	Drive RS-485 or Modbus RTU
Second reference setting	Switch from speed reference 1 to reference 2 via digital input
Trim reference setting	Available for speed reference offset via potentiometer, voltage input, or current input
Acceleration/deceleration time	0.05-3600 seconds (two acceleration and deceleration rates are selectable via digital inputs. Acceleration and deceleration patterns can be selected from linear or S-curve
DC injection braking	Starting frequency: 0.0-400 Hz Braking time: 0.0-60.0 seconds Braking level: 0-150% of rated current Braking time: 0.0-60.0 seconds Braking level: 0-150% of rated current
Frequency limit	0-400 Hz
Jump frequency control	Two jump (or skip) frequencies via parameter set to avoid mechanical vibration
Jogging operation	Operation via On key or digital input (Fwd or Rev)
Auto-restart after power failure	Restarts the drive without stopping after instantaneous power failure
Slip compensation	Maintains motor at constant speed with load fluctuations

Energy savings	Controls output voltage to minimize motor loss during constant speed operation
Start mode function	This functionality smoothly catches a spinning motor

Logic controller (LC)

Logic controller events	Over 23 types of programmable events
Comparators	Array of 4 comparators
Timers	Array of 3 timers, adjustable from 0.0 to 3600 sec
Logic rules	Array of 4 boolean logic rules
Logic controller states	Array of 20 logic controller action states

Process controller (PI)

Process CL feedback select	No function, analogue input 1, analogue input 2, pulse input, local bus reference
Process PI control	Normal or inverse
Process PI anti windup	Disabled or enabled
Process PI start speed	0.0-200 Hz
Process PI proportional gain	0.00-10.00
Process PI integral gain	0.10-9999 seconds
Process PI feed forward factor	0-400%
On reference bandwidth	0-200%

Indication

LEDs	Green - drive is on Yellow - indicates a warning Red - indicates an alarm
Monitor Units Available	Frequency, current, voltage, power, horsepower, % load, speed, or time

Trip codes

2	Live zero error
4	Line phase loss
7	DC overvoltage
8	DC undervoltage
9	Drive overload
10	Motor overtemperature
11	Motor thermistor overtemperature
12	Torque limit
13	Overcurrent
14	Ground fault
16	Short circuit
17	Control word timeout
25	Brake resistor short-circuited
27	Brake chopper short-circuited
28	Brake check
29	Power board overtemperature
30	Missing U phase
31	Missing V phase
32	Missing W phase
38	Internal fault
47	Control voltage fault
51	Auto tune check - wrong motor parameters
52	Auto tune low inom - motor current is too low
59	Current limit
63	Mechanical brake low
80	Drive restored to factory settings

Monitoring parameters available

Power	kW
Power	HP
Motor voltage	V
Frequency	Hz
Motor current	A
Frequency	%
Motor thermal	%
DC link voltage	V
Drive current	A
Drive max current	A
Logic controller state	ON/OFF

AF-6 drives

Intro

A

B

C

D

E

F

G

H

I

J/X



New

Dimensional drawings

Micro drives

Unit size	Nominal motor power ratings (kW)			Nominal motor power ratings (HP)			Height (mm)			Width (mm)		Depth (mm)	Weight kg
	230 V 1ph	230 V 3ph	400 V 3ph	230 V 1ph	230 V 3ph	400 V 3ph	A (including decoupling plate)	a	B	b	C		
M1	0.18 - 0.75	0.25 - 0.75	0.37 - 0.75	1/4 - 1	1/3 - 1	1/2 - 1	150	205	140.4	70	55	148	1.1
M2	1.5	1.5	1.5 - 2.2	2	2	2 - 3	176	230	166.4	75	59	168	1.6
M3	2.2	2.2 - 3.7	4 - 7.5	3	3 - 5	5 - 10	239	294	226	90	69	194	3.0
M4	-	-	11 - 15	-	-	15 - 20	292	347.5	272.4	125	97	249	6.0
M5	-	-	18.5 - 22	-	-	25 - 30	335	387.5	315	165	140	256	9.5

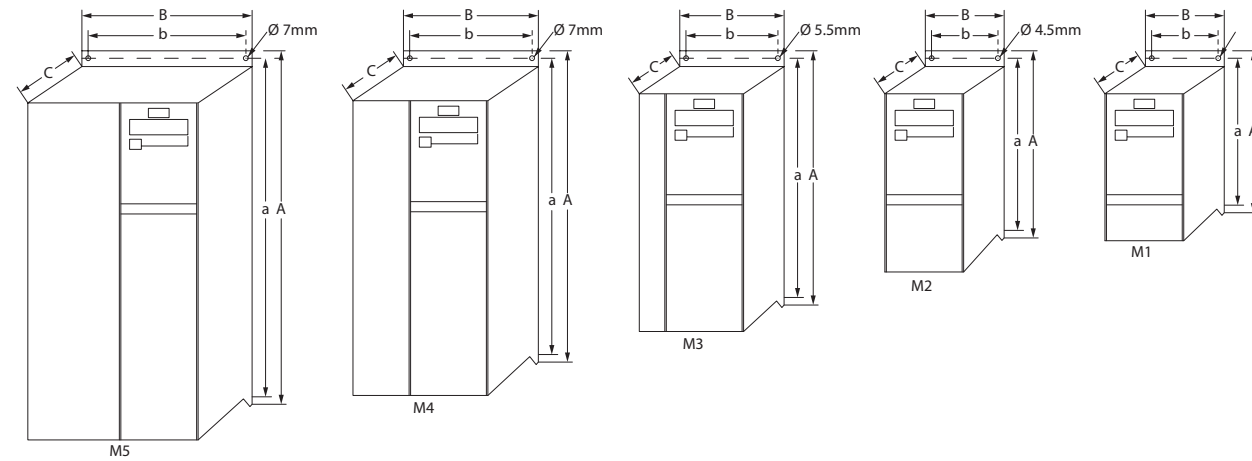

Micro drive keypad

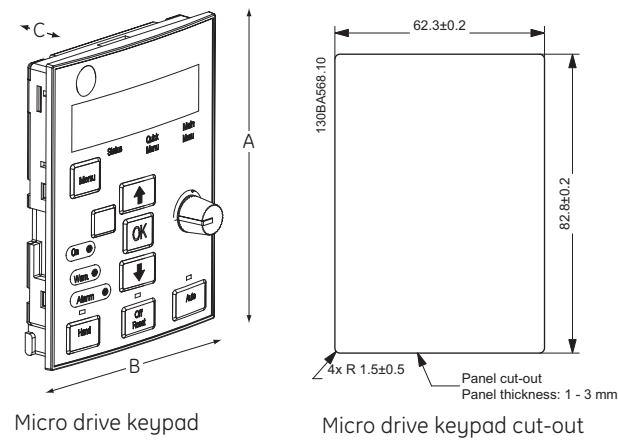

Height (mm) A	Width (mm) B	Depth (mm) C	Weight kg
85	65	28	0.08

Note: Please allow 5 cm between drives with field installed IP21/NEMA 1 kits. Also, please consult the relevant AF-6 Series drives Operating Instructions for recommended clearance above and below each drive rating.

Micro Drives

Intro

A

B

C

D

E

F

G

H

I

J/X



New



Dimensional drawings

DIN-rail mounting kit for 0.75kW / 1HP and below drives

Cat. No.	Ref. No.	A (mm)	B (mm)	C (mm)
RMACLP1	404806	60	129	13.5

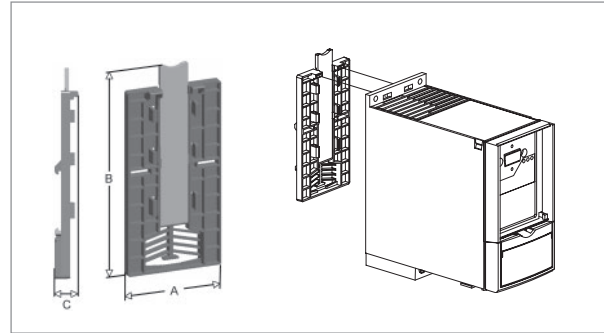

NEMA 1 field installed kit - top

Cat. No.	Ref. No.	A (mm)	B (mm)	C (mm)	D (mm)
NEMA1ACL1	404798	72	43	151	8
NEMA1ACL2	404799	77	43	172	8
NEMA1ACL3	404800	92	43	199	8

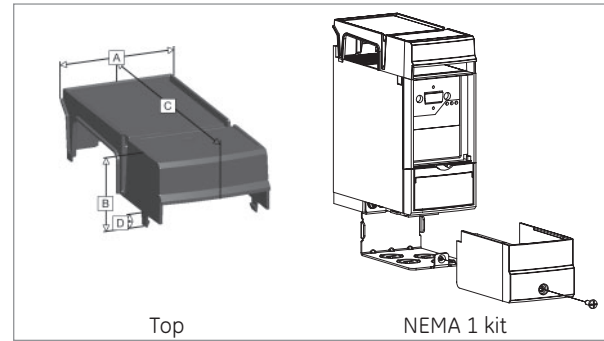

De-coupling plate kit

Cat. No.	Ref. No.	A (mm)	B (mm)	C (mm)	D (mm)	E (mm)
DEPLTACL1	404804	70	52	100	14	22.6
DEPLTACL2	404805	70	52	N/A	14	22.6

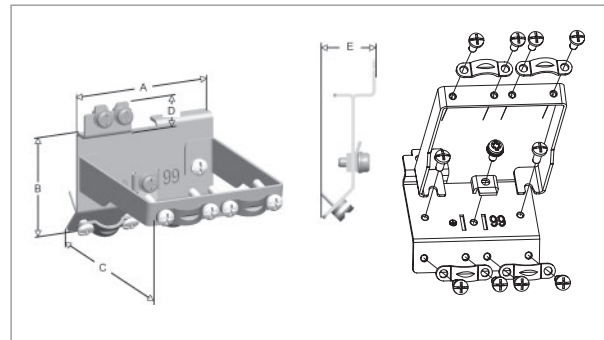

NEMA 1 field installed kit - bottom

Cat. No.	Ref. No.	A (mm)	B (mm)	C (mm)	D (mm)
NEMA1ACL1	404798	70	55	107	8
NEMA1ACL2	404799	75	55	114	8
NEMA1ACL3	404800	90	55	121	8

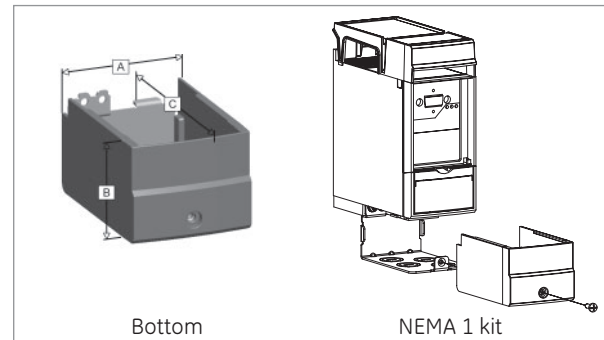

AF-6 drives

Intro

A

B

C

D

E

F

G

H

I

J/X



Notes

Large grid area for notes

Micro Drives

Intro

A

B

C

D

E

F

G

H

I

J/X



New



### AF-650 GP - General Purpose Drives

The AF-650 GP general purpose drive is a powerful, flexible and easy to use drive with many standard features. It is ideally suited for both heavy duty and light duty applications. The drive is available in its standard configuration that includes IP20 or IP00 chassis, LCD keypad display that can be remote mounted, DC link reactors, built-in Modbus RTU and RFI class A2 filter. Available in IP 55 and IP 66 enclosures.

Following models are available:

- Three-phase, 230Vac, from 0.25 to 45kW, 1/3 to 60HP
- Three-phase, 400Vac, from 0.37 to 1000kW, 1/2 to 1350HP
- Three-phase, 690Vac, from 11 to 1200kW, 15 to 1600HP

### Features

- Self-protecting features
- Other available configurations: RFI class A1/B1 filter, braking chopper and conformal coating.
- Configurations are available in IP55 and IP66
- RFI class A2 filter and DC link reactor as standard configuration
- Duality of power, Heavy or Light Duty
- 150% current overload for 1 minute (Heavy Duty)
- 110% current overload for 1 minute (Light Duty)
- Hot pluggable, illuminated LCD display, unit indications, rotation direction indication, trended charts display speed, torque, current, full alarm messages & descriptions
- Speed and process PID controls
- Integrated logic control, PLC
- "Pick up" start (catch a spinning motor)
- Precise stop function
- Advanced brake control
- 24V encoder feedback built-in
- Easy to use PC software
- Built-in communication networks for ModBus RTU
- Optional protocols: Profibus DP, Profinet, ModBus TPC/IP, Ethernet/IP and DeviceNet
- High standard protection class 3C2, optional class 3C3

### Approvals / Marking



UL, cUL, C-Tick

### Applications

Conveyors, mixers, agitators, lathes, spinning machines, machine tool, grinder, extruders, plastic injection molding machines, constant displacement pumps, woodworking machines.

### Product numbering system diagram

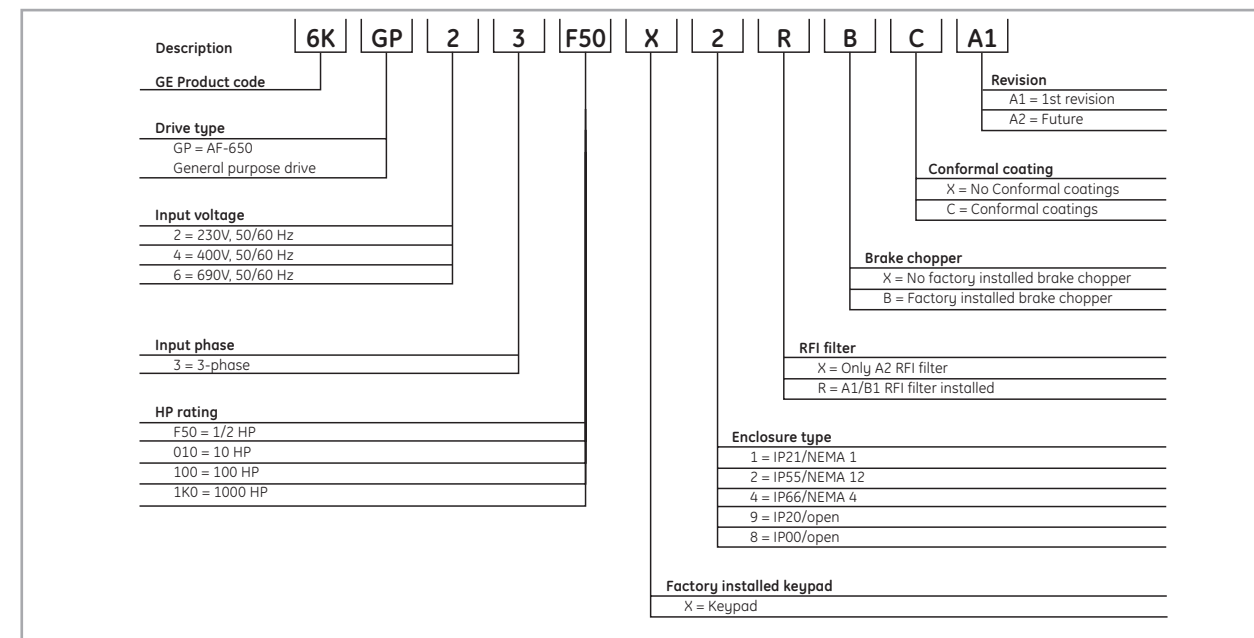

Product number for illustrative purposes only



New

IP00 / IP20 / IP21, with EMC filter Class A2, WITH braking chopper  
230V, 3-phase, 50/60Hz input

Heavy Duty rating Nominal motor ratings				Light Duty rating Nominal motor ratings				Enclosure type <sup>(1)</sup> :	Cat. No.	Ref. No.	Unit size
Power kW	Power HP	Current A	Overload current during 60s (A)	Power kW	Power HP	Current A	Overload current during 60s (A)				
0.25	1/3	1.8	2.88	0.25	1/3	1.8	2.88	IP20	6KGP23F33X9XBXA1	On request	12
0.37	1/2	2.4	3.84	0.37	1/2	2.4	3.84				12
0.75	1	4.6	7.36	0.75	1	4.6	7.36				12
1.5	2	7.5	12	1.5	2	7.5	12				12
2.2	3	10.6	16.96	2.2	3	10.6	16.96				12
3.7	5	16.7	26.72	3.7	5	16.7	26.72				13
5.5	7.5	24.2	38.72	5.5/7.5	7.5/10	30.8	33.88				23
7.5	10	30.8	49.28	11	15	46.2	50.82				23
11	15	46.2	73.92	15	20	59.4	65.34				24
15	20	59.4	89.1	18.5	25	74.8	82.28				24
18.5	25	74.8	112.2	22	30	88	96.8				33
22	30	88	132	30	40	115	126.5				33
30	40	115	172.5	37	50	143	157.3				34
37	50	143	214.5	45	60	170	187				34

400V, 3-phase, 50/60Hz input

Heavy Duty rating Nominal motor ratings				Light Duty rating Nominal motor ratings				Enclosure type <sup>(1)</sup> :	Cat. No.	Ref. No.	Unit size
Power kW	Power HP	Current A	Overload current during 60s (A)	Power kW	Power HP	Current A	Overload current during 60s (A)				
0.37	1/2	1.3	2.08	0.37	1/2	1.3	1.43	IP20	6KGP43F50X9XBXA1	403116	12
0.75	1	2.4	3.84	0.75	1	2.4	2.64				12
1.5	2	4.1	6.56	1.5	2	4.1	4.51				12
2.2	3	5.6	8.96	2.2	3	5.6	6.16				12
4	5	10	16	4	5	10	11				12
5.5	7.5	13	20.8	5.5	7.5	13	14.3				13
7.5	10	16	25.6	7.5	10	16	17.6				13
11	15	24	38.4	11/15	15/20	32	35.2				23
15	20	32	51.2	18.5	25	37.5	41.25				23
18.5	25	37.5	60	22	30	44	48.4				24
22	30	44	70.4	30	40	61	67.1				24
30	40	61	97.6	37	50	73	80.3				24
37	50	73	116.8	45	60	90	99				33
45	60	90	144	55	75	106	116.6				33
55	75	105	168	75	100	147	161.7				34
75	100	147	235.2	90	125	177	194.7				34
90	125	177	265.5	110	150	212	233.2				43
110	150	212	318	132	200	260	286	43			
132	200	260	390	160	250	315	346.5	44			
160	250	315	472.5	200	300	395	434.5	44			
200	300	395	592.5	250	350	480	528	44			
250	350	480	720	315	450	600	660	52			
315	450	600	900	355	500	658	723.8	52			
355	500	658	987	400	550	745	819.5	52			
400	550	745	1117.5	450	600	800	880	52			
450	600	800	1200	500	650	880	968	61			
500	650	880	1320	560	750	990	1089	61			
560	750	990	1485	630	900	1120	1232	61			
630	900	1120	1680	710	1000	1260	1386	61			
710	1000	1260	1890	800	1200	1460	1606	62			
800	1200	1460	2190	1000	1350	1700	1870	62			

690V<sup>(2)</sup>, 3-phase, 50/60Hz input

Heavy Duty rating Nominal motor ratings				Light Duty rating Nominal motor ratings				Enclosure type:	Cat. No.	Ref. No.	Unit size
Power kW	Power HP	Current A	Overload current during 60s (A)	Power kW	Power HP	Current A	Overload current during 60s (A)				
11	15	13	20.8	15	20	18	20	IP21/NEMA 1	6KGP63015X1XBXA1	403642	22
15	20	18	28.8	18.5	25	22	24				22
18.5	25	22	35.2	22	30	27	30				22
22	30	27	43.2	30	40	34	37				22
30	40	34	51	37	50	41	45				22
37	50	41	61.5	45	60	52	56				32
45	60	52	76.5	55	75	62	68				32
55	75	62	93	75	100	83	91				32
75	100	83	124.5	90	125	100	110				32
90	125	108	162	110	150	131	144				43
110	150	131	196.5	132	200	155	171				43
132	200	155	232.5	160	250	192	211				43
160	250	192	288	200	300	242	266				44
200	300	242	363	250	350	290	319				44
250	350	290	435	315	400	344	378				44
315	400	344	516	400	500	400	440				44
355	500	380	570	450	600	450	495				52
400	550	410	615	500	650	500	550	52			
500	650	500	750	560	750	570	627	52			
560	750	570	855	630	800	630	693	52			
630	900	630	945	710	1000	730	803	61			
710	1000	730	1095	800	1200	850	935	61			
800	1150	850	1275	900	1300	945	1040	61			
900	1250	945	1417.5	1000	1400	1060	1166	62			
1000	1350	1060	1590	1200	1600	1260	1386	62			
1200	1600	1260	1890	1400	1900	1415	1557	62			

[1] IP21/NEMA 1 kits are available as field installed options for all 230V drives from 0.25 to 37kW / 1/3 to 50HP for all 400V drives from 0.37 to 75kW / 1/2 to 100HP. See Page H.33.

[2] 690V horsepower ratings.

General Purpose Drives

Intro

A

B

C

D

E

F

G

H

I

J/X



New

IP00 / IP20 / IP21, with EMC filter Class A2, **WITHOUT** braking chopper  
 230V, 3-phase, 50/60Hz input

Heavy Duty rating Nominal motor ratings				Light Duty rating Nominal motor ratings				Enclosure type <sup>(1)</sup> :	Cat. No.	Ref. No.	Unit size
Power kW	Power HP	Current A	Overload current during 60s (A)	Power kW	Power HP	Current A	Overload current during 60s (A)				
0.25	1/3	1.8	2.88	0.25	1/3	1.8	2.88	IP20	6KGP23F33X9XXXA1	404670	12
0.37	1/2	2.4	3.84	0.37	1/2	2.4	3.84		6KGP23F50X9XXXA1	404671	12
0.75	1	4.6	7.36	0.75	1	4.6	7.36		6KGP23001X9XXXA1	404672	12
1.5	2	7.5	12	1.5	2	7.5	12		6KGP23002X9XXXA1	404673	12
2.2	3	10.6	16.96	2.2	3	10.6	16.96		6KGP23003X9XXXA1	404674	12
3.7	5	16.7	26.72	3.7	5	16.7	26.72		6KGP23005X9XXXA1	404675	13
5.5	7.5	24.2	38.72	5.5/7.5	7.5/10	30.8	33.88		6KGP23007X9XXXA1	404676	23
7.5	10	30.8	49.28	11	15	46.2	50.82		6KGP23010X9XXXA1	404677	23
11	15	46.2	73.92	15	20	59.4	65.34		6KGP23015X9XXXA1	404678	24
15	20	59.4	89.1	18.5	25	74.8	82.28		6KGP23020X9XXXA1	404679	24
18.5	25	74.8	112.2	22	30	88	96.8		6KGP23025X9XXXA1	404680	33
22	30	88	132	30	40	115	126.5		6KGP23030X9XXXA1	404681	33
30	40	115	172.5	37	50	143	157.3		6KGP23040X9XXXA1	404682	34
37	50	143	214.5	45	60	170	187		6KGP23050X9XXXA1	404683	34

400V, 3-phase, 50/60Hz input

Heavy Duty rating Nominal motor ratings				Light Duty rating Nominal motor ratings				Enclosure type <sup>(1)</sup> :	Cat. No.	Ref. No.	Unit size
Power kW	Power HP	Current A	Overload current during 60s (A)	Power kW	Power HP	Current A	Overload current during 60s (A)				
0.37	1/2	1.3	2.08	0.37	1/2	1.3	1.43	IP20	6KGP43F50X9XXXA1	400412	12
0.75	1	2.4	3.84	0.75	1	2.4	2.64		6KGP43001X9XXXA1	400451	12
1.5	2	4.1	6.56	1.5	2	4.1	4.51		6KGP43002X9XXXA1	401212	12
2.2	3	5.6	8.96	2.2	3	5.6	6.16		6KGP43003X9XXXA1	401362	12
4	5	10	16	4	5	10	11		6KGP43005X9XXXA1	402735	12
5.5	7.5	13	20.8	5.5	7.5	13	14.3		6KGP43007X9XXXA1	402738	13
7.5	10	16	25.6	7.5	10	16	17.6		6KGP43010X9XXXA1	402746	13
11	15	24	38.4	11/15	15/20	32	35.2		6KGP43015X9XXXA1	402747	23
15	20	32	51.2	18.5	25	37.5	41.25		6KGP43020X9XXXA1	402748	23
18.5	25	37.5	60	22	30	44	48.4		6KGP43025X9XXXA1	402765	24
22	30	44	70.4	30	40	61	67.1		6KGP43030X9XXXA1	402766	24
30	40	61	97.6	37	50	73	80.3		6KGP43040X9XXXA1	402767	24
37	50	73	116.8	45	60	90	99		6KGP43050X9XXXA1	402768	33
45	60	90	144	55	75	106	116.6		6KGP43060X9XXXA1	402769	33
55	75	105	168	75	100	147	161.7		6KGP43075X9XXXA1	402857	34
75	100	147	235.2	90	125	177	194.7		6KGP43100X9XXXA1	402863	34
90	125	177	265.5	110	150	212	233.2		6KGP43125X8XXXA1	402864	43
110	150	212	318	132	200	260	286	6KGP43150X8XXXA1	402865	43	
132	200	260	390	160	250	315	346.5	6KGP43200X8XXXA1	402866	44	
160	250	315	472.5	200	300	395	434.5	6KGP43250X8XXXA1	402867	44	
200	300	395	592.5	250	350	480	528	6KGP43300X8XXXA1	402868	44	
250	350	480	720	315	450	600	660	6KGP43350X8XXCA1	402869	52	
315	450	600	900	355	500	658	723.8	6KGP43450X8XXCA1	402870	52	
355	500	658	987	400	550	745	819.5	6KGP43500X8XXCA1	402871	52	
400	550	745	1117.5	450	600	800	880	6KGP43550X8XXCA1	402872	52	
450	600	800	1200	500	650	880	968	6KGP43600X1XXCA1	402873	61	
500	650	880	1320	560	750	990	1089	6KGP43650X1XXCA1	402874	61	
560	750	990	1485	630	900	1120	1232	6KGP43750X1XXCA1	402875	61	
630	900	1120	1680	710	1000	1260	1386	6KGP43900X1XXCA1	402876	61	
710	1000	1260	1890	800	1200	1460	1606	6KGP431K0X1XXCA1	402877	62	
800	1200	1460	2190	1000	1350	1700	1870	6KGP431K2X1XXCA1	402878	62	

690V<sup>(2)</sup>, 3-phase, 50/60Hz input

Heavy Duty rating Nominal motor ratings				Light Duty rating Nominal motor ratings				Enclosure type:	Cat. No.	Ref. No.	Unit size
Power kW	Power HP	Current A	Overload current during 60s (A)	Power kW	Power HP	Current A	Overload current during 60s (A)				
11	15	13	20.8	15	20	18	20	IP21/NEMA 1	6KGP63015X1XXXA1	403545	22
15	20	18	28.8	18.5	25	22	24		6KGP63020X1XXXA1	403546	22
18.5	25	22	35.2	22	30	27	30		6KGP63025X1XXXA1	403547	22
22	30	27	43.2	30	40	34	37		6KGP63030X1XXXA1	403548	22
30	40	34	51	37	50	41	45		6KGP63040X1XXXA1	403549	32
37	50	41	61.5	45	60	52	56		6KGP63050X1XXXA1	403550	32
45	60	52	76.5	55	75	62	68		6KGP63060X1XXXA1	403551	32
55	75	62	93	75	100	83	91		6KGP63075X1XXXA1	403552	32
75	100	83	124.5	90	125	100	110		6KGP63100X1XXXA1	403553	32
90	125	108	162	110	150	131	144		6KGP63125X8XXCA1	403554	43
110	150	131	196.5	132	200	155	171		6KGP63150X8XXCA1	403555	43
132	200	155	232.5	160	250	192	211		6KGP63200X8XXCA1	403556	43
160	250	192	288	200	300	242	266		6KGP63250X8XXCA1	403557	44
200	300	242	363	250	350	290	319		6KGP63300X8XXCA1	403558	44
250	350	290	435	315	400	344	378		6KGP63350X8XXCA1	403559	44
315	400	344	516	400	500	400	440		6KGP63400X8XXCA1	403560	44
355	500	380	570	450	600	450	495		6KGP63500X8XXCA1	403561	52
400	550	410	615	500	650	500	550	6KGP63550X8XXCA1	403562	52	
500	650	500	750	560	750	570	627	6KGP63650X8XXCA1	403563	52	
560	750	570	855	630	800	630	693	6KGP63750X8XXCA1	403564	52	
630	900	630	945	710	1000	730	803	6KGP63900X1XXCA1	403565	61	
710	1000	730	1095	800	1200	850	935	6KGP631K0X1XXCA1	403566	61	
800	1150	850	1275	900	1300	945	1040	6KGP631K1X1XXCA1	403567	61	
900	1250	945	1417.5	1000	1400	1060	1166	6KGP631K2X1XXCA1	403568	62	
1000	1350	1060	1590	1200	1600	1260	1386	6KGP631K3X1XXCA1	403569	62	
1200	1600	1260	1890	1400	1900	1415	1557	6KGP631K6X1XXCA1	404739	62	

(1) IP21/NEMA 1 kits are available as field installed options for all 230V drives from 0.25 to 37kW / 1/3 to 50HP for all 400V drives from 0.37 to 75kW / 1/2 to 100HP. See Page H.33.

(2) 690V horsepower ratings.

AF-6 drives  
Intro  
A  
B  
C  
D  
E  
F  
G  
H  
I  
J/X  
New  
H.34



**IP54 / IP55, with EMC filter Class A2, WITH braking chopper**  
**230V, 3-phase, 50/60Hz input**

Heavy duty rating				Light duty rating				Enclosure type:	Cat. No.	Ref. No.	Unit size
Nominal motor ratings			Overload current during 60s (A)	Nominal motor ratings			Overload current during 60s (A)				
Power kW	Power HP	Current A		Power kW	Power HP	Current A		Power kW	Power HP	Current A	
0.25	1/3	1.8	2.88	0.25	1/3	1.8	2.88	6KGP23F33X2XBXA1	on request	12	
0.37	1/2	2.4	3.84	0.37	1/2	2.4	3.84	6KGP23F50X2XBXA1			
0.75	1	4.6	7.36	0.75	1	4.6	7.36	6KGP23001X2XBXA1			
1.5	2	7.5	12	1.5	2	7.5	12	6KGP23002X2XBXA1			
2.2	3	10.6	16.96	2.2	3	10.6	16.96	6KGP23003X2XBXA1			
3.7	5	16.7	26.72	3.7	5	16.7	26.72	6KGP23005X2XBXA1			
5.5	7.5	24.2	38.72	5.5/7.5	7.5/10	30.8	33.88	6KGP23007X2XBXA1			
7.5	10	30.8	49.28	11	15	46.2	50.82	6KGP23010X2XBXA1			
11	15	46.2	73.92	15	20	59.4	65.34	6KGP23015X2XBXA1			
15	20	59.4	89.1	18.5	25	74.8	82.28	6KGP23020X2XBXA1			
18.5	25	74.8	112.2	22	30	88	96.8	6KGP23025X2XBXA1			
22	30	88	132	30	40	115	126.5	6KGP23030X2XBXA1			
30	40	115	172.5	37	50	143	157.3	6KGP23040X2XBXA1			
37	50	143	214.5	45	60	170	187	6KGP23050X2XBXA1			

**400V, 3-phase, 50/60Hz input**

Heavy Duty rating				Light Duty rating				Enclosure type:	Cat. No.	Ref. No.	Unit size
Nominal motor ratings			Overload current during 60s (A)	Nominal motor ratings			Overload current during 60s (A)				
Power kW	Power HP	Current A		Power kW	Power HP	Current A		Power kW	Power HP	Current A	
0.37	1/2	1.3	2.08	0.37	1/2	1.3	1.43	6KGP43F50X2XBXA1	403156	12	
0.75	1	2.4	3.84	0.75	1	2.4	2.64	6KGP43001X2XBXA1	403157	12	
1.5	2	4.1	6.56	1.5	2	4.1	4.51	6KGP43002X2XBXA1	403158	12	
2.2	3	5.6	8.96	2.2	3	5.6	6.16	6KGP43003X2XBXA1	403159	12	
4	5	10	16	4	5	10	11	6KGP43005X2XBXA1	403160	12	
5.5	7.5	13	20.8	5.5	7.5	13	14.3	6KGP43007X2XBXA1	403161	13	
7.5	10	16	25.6	7.5	10	16	17.6	6KGP43010X2XBXA1	403162	13	
11	15	24	38.4	11/15	15/20	32	35.2	6KGP43015X2XBXA1	403163	23	
15	20	32	51.2	18.5	25	37.5	41.25	6KGP43020X2XBXA1	403164	23	
18.5	25	37.5	60	22	30	44	48.4	6KGP43025X2XBXA1	403165	24	
22	30	44	70.4	30	40	61	67.1	6KGP43030X2XBXA1	403166	24	
30	40	61	97.6	37	50	73	80.3	6KGP43040X2XBXA1	403167	24	
37	50	73	116.8	45	60	90	99	6KGP43050X2XBXA1	403168	33	
45	60	90	144	55	75	106	116.6	6KGP43060X2XBXA1	403169	33	
55	75	105	168	75	100	147	161.7	6KGP43075X2XBXA1	403170	34	
75	100	147	235.2	90	125	177	194.7	6KGP43100X2XBXA1	403171	34	
90	125	177	265.5	110	150	212	233.2	6KGP43125X2XBXA1	403172	43	
110	150	212	318	132	200	260	286	6KGP43150X2XBXA1	403173	43	
132	200	260	390	160	250	315	346.5	6KGP43200X2XBXA1	403174	44	
160	250	315	472.5	200	300	395	434.5	6KGP43250X2XBXA1	403175	44	
200	300	395	592.5	250	350	480	528	6KGP43300X2XBXA1	403176	44	
250	350	480	720	315	450	600	660	6KGP43350X2XBXA1	403177	52	
315	450	600	900	355	500	658	723.8	6KGP43450X2XBXA1	403178	52	
355	500	658	987	400	550	745	819.5	6KGP43500X2XBXA1	403179	52	
400	550	745	1117.5	450	600	800	880	6KGP43550X2XBXA1	403180	52	
450	600	800	1200	500	650	880	968	6KGP43600X2XBXA1	403181	61	
500	650	880	1320	560	750	990	1089	6KGP43650X2XBXA1	403182	61	
560	750	990	1485	630	900	1120	1232	6KGP43750X2XBXA1	403183	61	
630	900	1120	1680	710	1000	1260	1386	6KGP43900X2XBXA1	403184	61	
710	1000	1260	1890	800	1200	1460	1606	6KGP431K0X2XBXA1	403185	62	
800	1200	1460	2190	1000	1350	1700	1870	6KGP431K2X2XBXA1	403186	62	

**690V, 3-phase, 50/60Hz input**

Heavy Duty rating				Light Duty rating				Enclosure type:	Cat. No.	Ref. No.	Unit size
Nominal motor ratings			Overload current during 60s (A)	Nominal motor ratings			Overload current during 60s (A)				
Power kW	Power HP	Current A		Power kW	Power HP	Current A		Power kW	Power HP	Current A	
11	15	13	20.8	15	20	18	20	6KGP63015X2XBXA1	403678	22	
15	20	18	28.8	18.5	25	22	24	6KGP63020X2XBXA1	403679	22	
18.5	25	22	35.2	22	30	27	30	6KGP63025X2XBXA1	403682	22	
22	30	27	43.2	30	40	34	37	6KGP63030X2XBXA1	403683	22	
30	40	34	51	37	50	41	45	6KGP63040X2XBXA1	403684	32	
37	50	41	61.5	45	60	52	56	6KGP63050X2XBXA1	403685	32	
45	60	52	76.5	55	75	62	68	6KGP63060X2XBXA1	403686	32	
55	75	62	93	75	100	83	91	6KGP63075X2XBXA1	403687	32	
75	100	83	124.5	90	125	100	110	6KGP63100X2XBXA1	403688	32	
90	125	108	162	110	150	131	144	6KGP63125X2XBXA1	403689	43	
110	150	131	196.5	132	200	155	171	6KGP63150X2XBXA1	403690	43	
132	200	155	232.5	160	250	192	211	6KGP63200X2XBXA1	403691	43	
160	250	192	288	200	300	242	266	6KGP63250X2XBXA1	403692	44	
200	300	242	363	250	350	290	319	6KGP63300X2XBXA1	403693	44	
250	350	290	435	315	400	344	378	6KGP63350X2XBXA1	403694	44	
315	450	344	516	400	500	400	440	6KGP63400X2XBXA1	403695	44	
355	500	380	570	450	600	450	495	6KGP63500X2XBXA1	403696	52	
400	550	410	615	500	650	500	550	6KGP63550X2XBXA1	403697	52	
500	650	500	750	560	750	570	627	6KGP63650X2XBXA1	403698	52	
560	750	570	855	630	800	630	693	6KGP63750X2XBXA1	403699	52	
630	900	630	945	710	1000	730	803	6KGP63900X2XBXA1	403700	61	
710	1000	730	1095	800	1200	850	935	6KGP631K0X2XBXA1	403701	61	
800	1150	850	1275	900	1300	945	1040	6KGP631K1X2XBXA1	403702	61	
900	1250	945	1417.5	1000	1400	1060	1166	6KGP631K2X2XBXA1	403703	62	
1000	1350	1060	1590	1200	1600	1260	1386	6KGP631K3X2XBXA1	403704	62	
1200	1600	1260	1890	1400	1900	1415	1557	6KGP631K6X2XBXA1	404740	62	

General Purpose Drives

Intro

A

B

C

D

E

F

G

H

I

J/X



New

IP54 / IP55, with EMC filter Class A2, **WITHOUT** braking chopper

230V, 3-phase, 50/60Hz input

Heavy duty rating				Light duty rating				Enclosure type:	Cat. No.	Ref. No.	Unit size			
Nominal motor ratings			Overload current during 60s (A)	Nominal motor ratings			Overload current during 60s (A)							
Power kW	Power HP	Current A		Power kW	Power HP	Current A								
0.25	1/3	1.8	2.88	0.25	1/3	1.8	2.88	IP55/NEMA 12	6KGP23F33X2XXXA1	404710	12			
0.37	1/2	2.4	3.84	0.37	1/2	2.4	3.84							
0.75	1	4.6	7.36	0.75	1	4.6	7.36							
1.5	2	7.5	12	1.5	2	7.5	12							
2.2	3	10.6	16.96	2.2	3	10.6	16.96							
3.7	5	16.7	26.72	3.7	5	16.7	26.72							
5.5	7.5	24.2	38.72	5.5/7.5	7.5/10	30.8	33.88							
7.5	10	30.8	49.28	11	15	46.2	50.82							
11	15	46.2	73.92	15	20	59.4	65.34							
15	20	59.4	89.1	18.5	25	74.8	82.28							
18.5	25	74.8	112.2	22	30	88	96.8							
22	30	88	132	30	40	115	126.5							
30	40	115	172.5	37	50	143	157.3							
37	50	143	214.5	45	60	170	187							
												6KGP23F50X2XXXA1	404711	12
												6KGP23001X2XXXA1	404712	12
												6KGP23002X2XXXA1	404713	12
								6KGP23003X2XXXA1	404714	12				
								6KGP23005X2XXXA1	404715	13				
								6KGP23007X2XXXA1	404716	23				
								6KGP23010X2XXXA1	404717	23				
								6KGP23015X2XXXA1	404718	24				
								6KGP23020X2XXXA1	404719	24				
								6KGP23025X2XXXA1	404720	33				
								6KGP23030X2XXXA1	404721	33				
								6KGP23040X2XXXA1	404722	34				
								6KGP23050X2XXXA1	404723	34				

400V, 3-phase, 50/60Hz input

Heavy Duty rating				Light Duty rating				Enclosure type:	Cat. No.	Ref. No.	Unit size			
Nominal motor ratings			Overload current during 60s (A)	Nominal motor ratings			Overload current during 60s (A)							
Power kW	Power HP	Current A		Power kW	Power HP	Current A								
0.37	1/2	1.3	2.08	0.37	1/2	1.3	1.43	IP55/NEMA 12	6KGP43F50X2XXXA1	402888	12			
0.75	1	2.4	3.84	0.75	1	2.4	2.64							
1.5	2	4.1	6.56	1.5	2	4.1	4.51							
2.2	3	5.6	8.96	2.2	3	5.6	6.16							
4	5	10	16	4	5	10	11							
5.5	7.5	13	20.8	5.5	7.5	13	14.3							
7.5	10	16	25.6	7.5	10	16	17.6							
11	15	24	38.4	11/15	15/20	32	35.2							
15	20	32	51.2	18.5	25	37.5	41.25							
18.5	25	37.5	60	22	30	44	48.4							
22	30	44	70.4	30	40	61	67.1							
30	40	61	97.6	37	50	73	80.3							
37	50	73	116.8	45	60	90	99							
45	60	90	144	55	75	106	116.6							
55	75	105	168	75	100	147	161.7							
75	100	147	235.2	90	125	177	194.7							
90	125	177	265.5	110	150	212	233.2							
110	150	212	318	132	200	260	286							
132	200	260	390	160	250	315	346.5							
160	250	315	472.5	200	300	395	434.5							
200	300	395	592.5	250	350	480	528							
250	350	480	720	315	450	600	660							
315	450	600	900	355	500	658	723.8							
355	500	658	987	400	550	745	819.5							
400	550	745	1117.5	450	600	800	880							
450	600	800	1200	500	650	880	968							
500	650	880	1320	560	750	990	1089							
560	750	990	1485	630	900	1120	1232							
630	900	1120	1680	710	1000	1260	1386							
710	1000	1260	1890	800	1200	1460	1606							
800	1200	1460	2190	1000	1350	1700	1870							
								IP54/NEMA 12 conformal coated	6KGP43040X2XXXA1	402899	24			
												6KGP43050X2XXXA1	402900	33
												6KGP43060X2XXXA1	402901	33
												6KGP43075X2XXXA1	402902	34
												6KGP43100X2XXXA1	402903	34
												6KGP43125X2XXXA1	403332	43
												6KGP43150X2XXXA1	403333	43
												6KGP43200X2XXXA1	403334	44
												6KGP43250X2XXXA1	403335	44
												6KGP43300X2XXXA1	403336	44
												6KGP43350X2XXXA1	402909	52
												6KGP43450X2XXXA1	402910	52
												6KGP43500X2XXXA1	402911	52
												6KGP43550X2XXXA1	402912	52
												6KGP43600X2XXXA1	402913	61
												6KGP43650X2XXXA1	402914	61
												6KGP43750X2XXXA1	402915	61
								6KGP43900X2XXXA1	402916	61				
								6KGP431K0X2XXXA1	402917	62				
								6KGP431K2X2XXXA1	402918	62				

690V, 3-phase, 50/60Hz input

Heavy Duty rating				Light Duty rating				Enclosure type:	Cat. No.	Ref. No.	Unit size			
Nominal motor ratings			Overload current during 60s (A)	Nominal motor ratings			Overload current during 60s (A)							
Power kW	Power HP	Current A		Power kW	Power HP	Current A								
11	15	13	20.8	15	20	18	20	IP55/NEMA 12	6KGP63015X2XXXA1	403581	22			
15	20	18	28.8	18.5	25	22	24							
18.5	25	22	35.2	22	30	27	30							
22	30	27	43.2	30	40	34	37							
30	40	34	51	37	50	41	45							
37	50	41	61.5	45	60	52	56							
45	60	52	76.5	55	75	62	68							
55	75	62	93	75	100	83	91							
75	100	83	124.5	90	125	100	110							
90	125	108	162	110	150	131	144							
110	150	131	196.5	132	200	155	171							
132	200	155	232.5	160	250	192	211							
160	250	192	288	200	300	242	266							
200	300	242	363	250	350	290	319							
250	350	290	435	315	400	344	378							
315	450	344	516	400	500	400	440							
355	500	380	570	450	600	450	495							
400	550	410	615	500	650	500	550							
500	650	500	750	600	750	570	627							
560	750	570	855	630	800	630	693							
630	900	630	945	710	1000	730	803							
710	1000	730	1095	800	1200	850	935							
800	1150	850	1275	900	1300	945	1040							
900	1250	945	1417.5	1000	1400	1060	1166							
1000	1350	1060	1590	1200	1600	1260	1386							
1200	1600	1260	1890	1400	1900	1415	1557							
								IP54/NEMA 12 conformal Coated	6KGP63300X2XXXA1	403594	44			
												6KGP63350X2XXXA1	403595	44
												6KGP63400X2XXXA1	403596	44
												6KGP63500X2XXXA1	403597	52
												6KGP63550X2XXXA1	403598	52
												6KGP63650X2XXXA1	403599	52
												6KGP63750X2XXXA1	403600	52
												6KGP63900X2XXXA1	403601	61
												6KGP631K0X2XXXA1	403602	61
												6KGP631K1X2XXXA1	403603	61
												6KGP631K2X2XXXA1	403604	62
												6KGP631K3X2XXXA1	403605	62
												6KGP631K6X1XXXA1	404741	62

AF-6 drives  
Intro  
A  
B  
C  
D  
E  
F  
G  
H  
I  
J/X



New

**IP66, with EMC filter Class A2, WITH braking chopper**  
**230V, 3-phase, 50/60Hz input**

Heavy Duty rating				Light Duty rating				Cat. No.	Ref. No.	Unit size
Nominal motor ratings			Overload current during 60s (A)	Nominal motor ratings			Overload current during 60s (A)			
Power kW	Power HP	Current A		Power kW	Power HP	Current A				
0.25	1/3	1.8	2.88	0.25	1/3	1.8	2.88	6KGP23F33X4XBXA1		12
0.37	1/2	2.4	3.84	0.37	1/2	2.4	3.84	6KGP23F50X4XBXA1		12
0.75	1	4.6	7.36	0.75	1	4.6	7.36	6KGP23001X4XBXA1		12
1.5	2	7.5	12	1.5	2	7.5	12	6KGP23002X4XBXA1		12
2.2	3	10.6	16.96	2.2	3	10.6	16.96	6KGP23003X4XBXA1		12
3.7	5	16.7	26.72	3.7	5	16.7	26.72	6KGP23005X4XBXA1		13
5.5	7.5	24.2	38.72	5.5/7.5	7.5/10	30.8	33.88	6KGP23007X4XBXA1	on request	23
7.5	10	30.8	49.28	11	15	46.2	50.82	6KGP23010X4XBXA1		23
11	15	46.2	73.92	15	20	59.4	65.34	6KGP23015X4XBXA1		24
15	20	59.4	89.1	18.5	25	74.8	82.28	6KGP23020X4XBXA1		24
18.5	25	74.8	112.2	22	30	88	96.8	6KGP23025X4XBXA1		33
22	30	88	132	30	40	115	126.5	6KGP23030X4XBXA1		33
30	40	115	172.5	37	50	143	157.3	6KGP23040X4XBXA1		34
37	50	143	214.5	45	60	170	187	6KGP23050X4XBXA1		34

**400V, 3-phase, 50/60Hz input**

Heavy Duty rating				Light Duty rating				Cat. No.	Ref. No.	Unit size
Nominal motor ratings			Overload current during 60s (A)	Nominal motor ratings			Overload current during 60s (A)			
Power kW	Power HP	Current A		Power kW	Power HP	Current A				
0.37	1/2	1.3	2.08	0.37	1/2	1.3	1.43	6KGP43F50X4XBXA1	403187	12
0.75	1	2.4	3.84	0.75	1	2.4	2.64	6KGP43001X4XBXA1	403188	12
1.5	2	4.1	6.56	1.5	2	4.1	4.51	6KGP43002X4XBXA1	403189	12
2.2	3	5.6	8.96	2.2	3	5.6	6.16	6KGP43003X4XBXA1	403190	12
4	5	10	16	4	5	10	11	6KGP43005X4XBXA1	403191	12
5.5	7.5	13	20.8	5.5	7.5	13	14.3	6KGP43007X4XBXA1	403192	13
7.5	10	16	25.6	7.5	10	16	17.6	6KGP43010X4XBXA1	403193	13
11	15	24	38.4	11/15	15/20	32	35.2	6KGP43015X4XBXA1	403194	23
15	20	32	51.2	18.5	25	37.5	41.25	6KGP43020X4XBXA1	403195	23
18.5	25	37.5	60	22	30	44	48.4	6KGP43025X4XBXA1	403196	24
22	30	44	70.4	30	40	61	67.1	6KGP43030X4XBXA1	403197	24
30	40	61	97.6	37	50	73	80.3	6KGP43040X4XBXA1	403198	24
37	50	73	116.8	45	60	90	99	6KGP43050X4XBXA1	403199	33
45	60	90	144	55	75	106	116.6	6KGP43060X4XBXA1	403200	33
55	75	106	169.6	75	100	147	161.7	6KGP43075X4XBXA1	403201	34
75	100	147	235.2	90	125	177	194.7	6KGP43100X4XBXA1	403202	34

General Purpose Drives

Intro

A

B

C

D

E

F

G

H

I

J/X



New



IP66, with EMC filter Class A2, **WITHOUT** braking chopper  
230V, 3-phase, 50/60Hz input

Heavy Duty rating				Light Duty rating				Cat. No.	Ref. No.	Unit size
Nominal motor ratings				Nominal motor ratings						
Power kW	Power HP	Current A	Overload current during 60s (A)	Power kW	Power HP	Current A	Overload current during 60s (A)			
0.25	1/3	1.8	2.88	0.25	1/3	1.8	2.88	6KGP23F33X4XXXA1	404724	12
0.37	1/2	2.4	3.84	0.37	1/2	2.4	3.84	6KGP23F50X4XXXA1	404725	12
0.75	1	4.6	7.36	0.75	1	4.6	7.36	6KGP23001X4XXXA1	404726	12
1.5	2	7.5	12	1.5	2	7.5	12	6KGP23002X4XXXA1	404727	12
2.2	3	10.6	16.96	2.2	3	10.6	16.96	6KGP23003X4XXXA1	404728	12
3.7	5	16.7	26.72	3.7	5	16.7	26.72	6KGP23005X4XXXA1	404729	13
5.5	7.5	24.2	38.72	5.5/7.5	7.5/10	30.8	33.88	6KGP23007X4XXXA1	404730	23
7.5	10	30.8	49.28	11	15	46.2	50.82	6KGP23010X4XXXA1	404731	23
11	15	46.2	73.92	15	20	59.4	65.34	6KGP23015X4XXXA1	404732	24
15	20	59.4	89.1	18.5	25	74.8	82.28	6KGP23020X4XXXA1	404733	24
18.5	25	74.8	112.2	22	30	88	96.8	6KGP23025X4XXXA1	404734	33
22	30	88	132	30	40	115	126.5	6KGP23030X4XXXA1	404735	33
30	40	115	172.5	37	50	143	157.3	6KGP23040X4XXXA1	404736	34
37	50	143	214.5	45	60	170	187	6KGP23050X4XXXA1	404737	34

400V, 3-phase, 50/60Hz input

Heavy Duty rating				Light Duty rating				Cat. No.	Ref. No.	Unit size
Nominal motor ratings				Nominal motor ratings						
Power kW	Power HP	Current A	Overload current during 60s (A)	Power kW	Power HP	Current A	Overload current during 60s (A)			
0.37	1/2	1.3	2.08	0.37	1/2	1.3	1.43	6KGP43F50X4XXXA1	402919	12
0.75	1	2.4	3.84	0.75	1	2.4	2.64	6KGP43001X4XXXA1	402920	12
1.5	2	4.1	6.56	1.5	2	4.1	4.51	6KGP43002X4XXXA1	402921	12
2.2	3	5.6	8.96	2.2	3	5.6	6.16	6KGP43003X4XXXA1	402922	12
4	5	10	16	4	5	10	11	6KGP43005X4XXXA1	402923	12
5.5	7.5	13	20.8	5.5	7.5	13	14.3	6KGP43007X4XXXA1	402924	13
7.5	10	16	25.6	7.5	10	16	17.6	6KGP43010X4XXXA1	402925	13
11	15	24	38.4	11/15	15/20	32	35.2	6KGP43015X4XXXA1	402926	23
15	20	32	51.2	18.5	25	37.5	41.25	6KGP43020X4XXXA1	402927	23
18.5	25	37.5	60	22	30	44	48.4	6KGP43025X4XXXA1	402928	24
22	30	44	70.4	30	40	61	67.1	6KGP43030X4XXXA1	402929	24
30	40	61	97.6	37	50	73	80.3	6KGP43040X4XXXA1	402930	24
37	50	73	116.8	45	60	90	99	6KGP43050X4XXXA1	402931	33
45	60	90	144	55	75	106	116.6	6KGP43060X4XXXA1	402932	33
55	75	106	169.6	75	100	147	161.7	6KGP43075X4XXXA1	402933	34
75	100	147	235.2	90	125	177	194.7	6KGP43100X4XXXA1	402934	34

AF-6 drives

Intro

A

B

C

D

E

F

G

H

I

J/X



Options and accessories

Field installed IP21/NEMA 1 add-on option kits

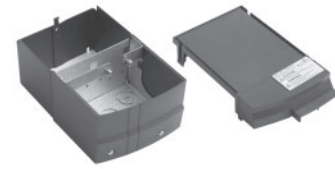

Voltage	Rating kW	Rating HP	IP21/NEMA 1 Kit Cat. No.	Ref. No.
230	0.25	1/3	NEMA1ACA2	404831
	0.37	1/2	NEMA1ACA2	404831
	0.75	1	NEMA1ACA2	404831
	1.5	2	NEMA1ACA2	404831
	2.2	3	NEMA1ACA2	404831
	3.7	5	NEMA1ACA3	404832
	5.5	7.5	NEMA1ACB3	404833
	7.5	10	NEMA1ACB3	404833
	11	15	NEMA1ACB4	404834
	15	20	NEMA1ACB4	404834
	18.5	25	NEMA1ACC3	404835
	22	30	NEMA1ACC3	404835
	30	40	NEMA1ACC4	404836
	37	50	NEMA1ACC4	404836
400	0.37	1/2	NEMA1ACA2	404831
	0.75	1	NEMA1ACA2	404831
	1.5	2	NEMA1ACA2	404831
	2.2	3	NEMA1ACA2	404831
	3.7	5	NEMA1ACA2	404831
	5.5	7.5	NEMA1ACA3	404832
	7.5	10	NEMA1ACA3	404832
	11	15	NEMA1ACB3	404833
	15	20	NEMA1ACB3	404833
	18.5	25	NEMA1ACB4	404834
	22	30	NEMA1ACB4	404834
	30	40	NEMA1ACB4	404834
	37	50	NEMA1ACC3	404835
	45	60	NEMA1ACC3	404835
55	75	NEMA1ACC4	404836	
75	100	NEMA1ACC4	404836	

Remote mounting kit for graphical LCD keypad



Remote mounting kit for mounting graphical LCD Keypad on enclosure door. kit includes gasket, mounting brackets, and cable. Keypad is rated IP65.

Description	Cat. No.	Ref. No.
Remote mounting kit for graphical LCD keypad	RMKYPDAC	404797
Remote mounting kit without cable	OPCRMKNC	404850

Communications modules



<b>Profibus DP communications module</b> Profibus DP internal drive mounted module for use on AF-650 GP and AF-600 FP drives. Supports Profibus DP V1 communications networks.	OPCPDP	404848
<b>DeviceNet communications module</b> DeviceNet internal drive mounted module for use on AF-650 GP and AF-600 FP drives. ODVA certified device.	OPCDEV	404818
<b>Ethernet IP communications module(1)</b> Ethernet IP internal drive mounted module for use on AF-650 GP and AF-600 FP drives. ODVA certified device. Features 2-port built-in switch. Also includes webserver and e-mail notification.	OPCEIP	404820
<b>Modbus TCP communications module</b> Modbus TCP internal drive mounted module for use on AF-650 GP and AF-600 FP drives.	OPCMBTCP	404824
<b>ProfiNet RT communications module</b> ProfiNet RT internal drive mounted module for use on AF-650 GP and AF-600 FP drives.	OPCPRT	404825

(1) Requires I/O and network slots and cannot be used with any other network or I/O modules.

General Purpose Drives

Intro

A

B

C

D

E

F

G

H

I

J/X



New

Options and accessories (continued)

**General purpose I/O module**



General purpose I/O internal drive mounted module for use on AF-650 GP and AF-600 FP drives. Module includes: 3x digital inputs 24V  
2x digital outputs PNP/NPN  
2x analogue inputs 0-10V  
1x analogue output 0/4-20mA

Description	Cat. No.	Ref. No.
General purpose I/O module	OPCGPIO	404821

**Encoder module**

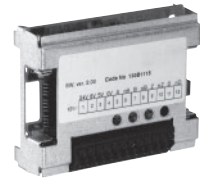

Encoder internal drive mounted module for use on the AF-650 GP drive. Module supports all 5V incremental encoders. Also supports hyperface sincos encoders.

Description	Cat. No.	Ref. No.
Encoder input module	OPCENC	404819

**Resolver module**

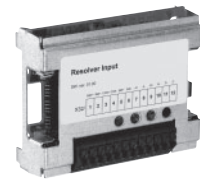

Resolver internal drive mounted module for use on the AF-650 GP drive. Module supports 4-8Vrms, 2.5kHz - 15kHz, 50mA resolvers. Resolution is 10bit at 4Vrms.

Description	Cat. No.	Ref. No.
Resolver input module	OPCRES	404852

**Relay output module**



Relay output internal drive mounted module for use on the AF-650 GP. Module adds (3) Form C relay outputs to the drive. Relays are rated at 2A at 240V resistive load.

Description	Cat. No.	Ref. No.
Relay output module	OPCRLY	404849

**24V DC External supply module**



24V DC external supply internal drive mounted module for use on the AF-650 GP drives. This module accepts an external 24V DC supply which is used to keep the control board of the drive and other option modules powered in the event of a Line side power outage. Can be used with Communications and I/O Modules.

Description	Cat. No.	Ref. No.
24V DC External supply module	OPC24VPS	404815

**Safe PLC I/O module**



Safe PLC I/O internal drive mounted module for use on the AF-650 GP drive. This module provides a safety input based on a single pole 24V DC input.

Description	Cat. No.	Ref. No.
Safe PLC I/O Module	OPCSAFE	404853

AF-6 drives

Intro

A

B

C

D

E

F

G

H

I

J/X

Options and accessories (continued)

**Screw terminal accessory**

Screw terminal accessory is available for field installation on AF-650 GP drives. These screw terminals can replace the cage clamp terminals which ship with each drive. This set of three terminals are for the digital inputs, analog I/O, and RS485 connection.



Description	Cat. No.	Ref. No.
Screw terminal accessory	OPCSTERM	404822

**Pedestal kit**

Pedestal kit allows unit size 41 and 42 drives to be floor mounted (IP21/NEMA 1 and IP55/NEMA 12, 90 to 200/315kW / 125 to 300/400HP at 400/690V for AF-650 GP).

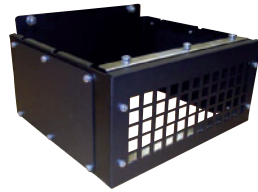

Description	Cat. No.	Ref. No.
Pedestal kit	OPC4XPED	404845

**USB kit**

This kit allows for the USB programming terminal to be brought out to the front cover of the drive. Works with all drive types.



For all drives up to unit size 5X	OPCUSB	404861
For all unit size 6X drives	OPCUSB6X	404860

**Power shields**

These shields are used to cover the drive power terminals on NEMA 1 and NEMA 12 drive types.

For Unit size 41 and 42 drives	OPCCOVER4142	404846
For Unit size 51 drives	OPCCOVER51	404847

General Purpose Drives

Intro

A

B

C

D

E

F

G

H

I

J/X



New

Basic wiring diagrams

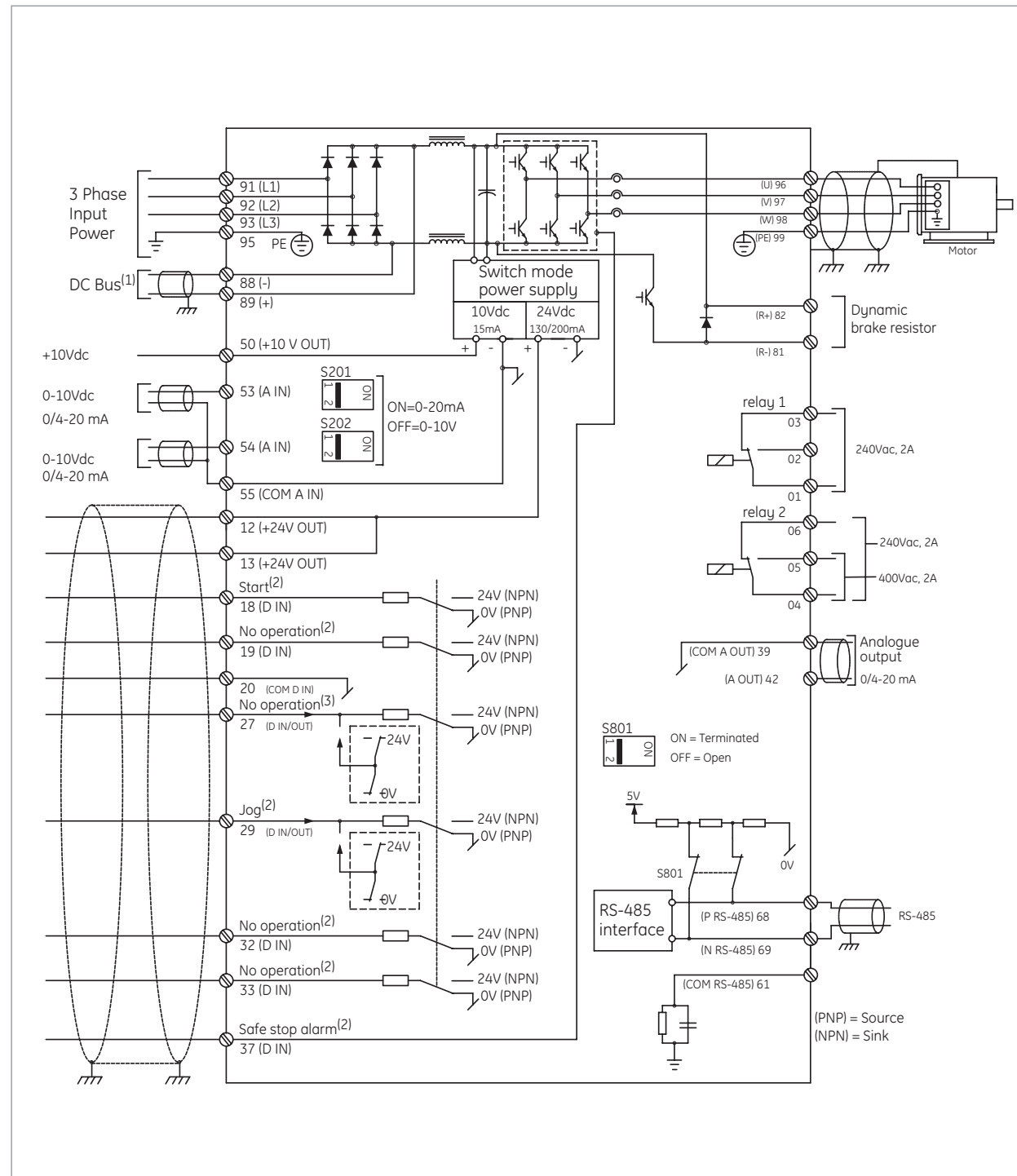

- (1) These terminals are only available with optional factory installed brake chopper.
- (2) Indicates default setting; see parameter group E-## to re-program.
- (3) Indicates default setting for version 1.10 drives or higher. Prior versions are set to coast inverse, indicating that terminal #27 must be logic "high" to enable the drive to run. See parameter E-03 terminal 27 digital input to re-program.

AF-6 drives  
Intro  
A  
B  
C  
D  
E  
F  
G  
H  
I  
J/X



## Specifications

### Environmental conditions

Enclosures	IP20 chassis, IP00 chassis, IP21/NEMA 1, IP55/NEMA 12, IP54/NEMA 12, IP66/NEMA 4
Installation location	Do not install in locations where product could be exposed to dust, corrosive gas, inflammable gas, oil mist, vapor, water drops or direct sunlight. There must be no salt in the atmosphere. Condensation must not be caused by sudden changes in temperature. For use at altitudes of 3280 ft. (1000 m) or less without derating.
Storage temperature	-25° to 65° C
Ambient temperature	-10° to +50° C (24 hour average max of 45°C)
Ambient humidity	5 to 95 % RH (non-condensing)
Vibration	1.0G
Cooling method	Fan cooled all ratings. Fan control auto, 50 % level, 75 % level, 100 % level adjustable

### Standards

Approvals	CE, UL, cUL, and C-Tick Suitable for use on a circuit capable of delivering not more than 100,000 rms symmetrical amperes for 230V and 400V.
-----------	---

### Input power supply

Rated Input AC voltage	200-240 Vac, 3-phase, 50-60 Hz, +/- 10% V 380-500 Vac, 3-phase, 50-60 Hz, +/- 10% V 525-690 Vac, 3-phase, 50-60 Hz, +/- 10% V
Maximum voltage imbalance	3% of rated supply voltage
True power factor	> 0.9 at rated load
Displacement power factor	> 0.98
Switching on input power supply	Maximum twice/minute up to 7.5kW/10HP, maximum once/minute above 7.5kW/10HP
Environment according to EN60664-1	Overvoltage category III/pollution degree 2

### Output

Rated output voltage	0-100% of supply voltage
Output frequency	0-1000 Hz; 0-800Hz for 400V above 710kW/100HP and 690V above 710kW/100HP
Switching on output	Unlimited
Accel/decel times	0.01-3600 seconds
Overload current rating	Sinusoidal PWM control (V/Hz, Adv. vector control, sensorless vector, and flux vector with motor feedback)

### Control

Starting torque	160% starting torque for 1 minute (constant torque), 110% starting torque for 1 minute (variable torque)
Carrier frequency (motor noise)	Selectable - 1, 1.5, 2, 2.5, 3, 3.5, 4, 5, 6, 7, 8, 10, 12, 14, 16 kHz
Torque boost	Selectable by up to 5 individual V/Hz settings in V/Hz Mode or by 0 - 300% setting of torque boost parameter in Adv. vector mode
Acceleration/deceleration time	0.01-3600 seconds (4 acceleration and deceleration times are selectable via digital inputs. Acceleration and deceleration patterns can be selected from linear or deceleration patterns can be selected from linear or S-curve)
Data protection	Passw protection for quick menu or main menu, 0-9999.
Pattern operation	Settings via built-in logic controller sequencer
Jump frequency control	4 jump (or skip) frequencies via parameter set to avoid mechanical vibration
Slip compensation	Maintains motor at constant speed with load fluctuations
Torque limit control	Output torque can be controlled within a range of 0.0 to 160% (0.1 and steps)
8 preset speeds	8 programmable preset speeds selectable by 3 digital inputs
Trim reference setting	Available for speed reference offset via potentiometer, voltage input, or current input
DC injection braking	Starting frequency: 0.0-1000 Hz, 0-800Hz for 400V above 710kW/100HP and 690V above 37kW/50HP Braking time: 0.0-60.0 seconds Braking level: 0-100% of rated current
Jogging operation	Operation via on key or digital input (Fwd or Rev)
Auto-restart after power failure	Restarts the drive without stopping after instantaneous power failure

Energy savings	Controls output voltage to minimize motor loss during constant speed operation
Start mode function	This functionality smoothly catches a spinning motor

### Logic controller (LC)

Logic controller events	Up to 37 types of programmable events
Comparators	Array of 6 comparators
Timers	Array of 8 timers, adjustable from 0.0 to 3600 sec
Logic rules	Array of 6 boolean logic rules
Logic controller states	Array of 20 logic controller action states

### Process controller (PI)

Process CL feedback select	Up to 2 references. Selectable - no function, motor feedback, separate encoder, encoder option module, or resolver option module
Process PID control	Normal or inverse
Process PID anti windup	Disabled or enabled
Process PID start speed	0.0-200 Hz
Process PID proportional gain	0.00-10.00
Process PID integral time	0.1 - 10000.0 ms
Process PID differential time	0.0 - 10 s
Process PID differential gain	1.0-50.00
Process PID feed forward factor	0-500%
On reference bandwidth	0-200%

### Operation

Operation method	Keypad operation: hand, off, auto digital input: programmable for start/stop, forward/reverse, jog timer operation: stop after predetermined time frame Built-in RS-485 Modbus USB port for programming drive with optional PC software
Frequency reference signal	Left or right arrow buttons on keypad in manual mode Speed potentiometer: 0 to +10Vdc, 10 to 0Vdc 0-10Vdc analog input 0/4-20mA analog input
References	Up to 3 input references can be selected from analog input #1 or #2, frequency input #1 or #2, network, or potentiometer
Input signals	6x digital inputs, 24 Vdc PNP or NPN 1x safe stop digital input suitable for category 3 installations to meet EN-954-1 2x pulse inputs rated to 110kHz or 1x pulse input and 1 - encoder Input 24Vdc rated to 4096 PPR 2x analog inputs -10 to +10V scalable or 0/4 to 20 mA scalable Digital input settings: No operation Reset after drive trip or alarm Reset after drive trip or alarm Drive at stop with no holding current Quick stop according to quick stop decel time 1 Stop on input going low Start Maintained start arfter signal applied for Minimum of 2ms Reversing Start reverse Enable start forward only Jog Multi-step frequency selection (1 to 8 Steps) Hold drive frequency Hold reference Speed up; activated by hold drive frequency or Hold reference Slow down; activated by hold drive frequency or hold reference Drive parameter setup select 1-4 Precise start or stop; activated when drive parameter precise start or stop function is selected Catch up or slow down; activated by signal to add to or subtract from input reference to control speed Pulse input selectable from 100 - 110000Hz Accel / decel time select. Set input to accel / decel times 1 to 4 Digital potentiometer Input Increase or Decrease Mechanical Brake Feedback

Continued on next page

## General Purpose Drives

Intro

A

B

C

D

E

F

G

H

I

J/X



New

Specifications

Operation (continued)

<b>Output signals</b>	2x digital outputs 24 Vdc (digital outputs are used in place of 2 of the digital inputs) 2x form C relays rated to 2A at 230 Vac 1x analog output 0/4 to 20mA Relay output settings: No operation Control ready Drive ready Drive ready in remote Standby no drive warnings Drive running Drive running no drive warnings Drive running on remote Alarm Alarm or warning At torque limit Out of current range Below current Above current Out of speed range Below speed Above speed Out of feedback range Below feedback Above feedback Thermal overload warning Reverse Bus OK Torque limit and stopped Brake and no warning Brake ready and no faults Brake chopper fault External interlock Out of external reference range Below external reference Above external reference Fieldbus controlling drive No alarm Running in reverse Local mode active Remote mode active Start command active Hand mode active Auto mode active
<b>Protective functions</b>	Line phase loss DC overvoltage DC undervoltage Drive overload Motor overtemperature Motor thermistor overtemperature Torque limit Overcurrent Ground fault Short circuit Control word timeout Brake resistor short-circuited Brake chopper short-circuited Brake check DC Link voltage high DC Link voltage low Internal fan fault External fan fault Power board overtemperature Missing U phase Missing V phase Missing W phase Internal fault Control voltage fault Auto tune check - wrong motor parameters Auto Tune low inom - motor current is too low Current limit Mechanical brake low Drive initialized to default value Keypad error No motor Soft charge fault Auto tuning fault Serial comms bus fault Hardware mismatch Speed limit

Keypad

<b>Keypad features</b>	LCD display with 6 alpha-numeric lines. multi-language support Hot pluggable, remote mount option, and copy-cat feature, IP65 rating when remote mounted on enclosure LED's - green - drive is on, yellow - indicates a warning, red - indicates an alarm, amber - indicates active menu keys and h-o-a keys
<b>Keypad keys</b>	Status - shows status of drive Quick Menu - enters quick start, parameter data check, or trending modes Alarm log - used to display alarm list Back - reverts to previous step or layer in parameter structure Cancel - used to cancel last change or command Info - displays information about a command, parameter, or function in any display. Hand/off/auto - used to control drive locally or put drive in remote mode Reset - used to reset warnings or alarms
<b>Password</b>	2 level password protection
<b>Alternate motor parameters</b>	Up to 4 separate complete parameter set-ups are available
<b>Graphical trending</b>	Trend speed, power, frequency or any value programmed in status display

RS485 modbus RTU serial communications

<b>Physical level</b>	EIA/RS485
<b>Transmission distance</b>	1640 ft (500m)
<b>Node address</b>	32
<b>Transmission speed</b>	2400, 4800, 9600, 19200, 38400 or 115200 (bits/s)
<b>Transmission mode</b>	Half duplex
<b>Transmission protocol</b>	Modbus RTU
<b>Character code</b>	Binary
<b>Character length</b>	8 bits
<b>Error check</b>	CRC

Mounting clearance

<b>Starting torque</b>	All AF-650 GP drives can be mounted side-by-side without spacing. For all drives rated 75kW/100HP or below allow 3.4 inches (100 mm) free space above and below. For all drives rated 90kW/125HP and above allow 8.9 inches (225 mm) free space above and below.
------------------------	--

AF-6 drives

Intro

A

B

C

D

E

F

G

H

I

J/X



Heavy Duty efficiency, Watt loss, unit size, dimensions and weights

230 Vac

Nominal motor ratings			Efficiency			Watt loss (W)	Unit size	Drive type	Height (mm)	Width (mm)	Depth (mm)	Weight (kg)
Power kW	Power HP	Current A	at 5 kHz (%)	at 4 kHz (%)	at 3 kHz (%)							
0.25	1/3	1.8	94			21	12	IP20 chassis	375	90	220	5
0.37	1/2	2.4	94			29	12	IP20 chassis	375	90	220	5
0.75	1	4.6	95			54	12	IP20 chassis	375	90	220	5
1.5	2	7.5	96			82	12	IP20 chassis	375	90	220	5
2.2	3	10.6	96			115	12	IP20 chassis	374	130	220	7
3.7	5	16.7	96			185	13	IP20 chassis	420	165	262	12
5.5	7.5	24.2		96.4		239	23	IP20 chassis	420	165	262	12
7.5	10	30.8		95.9		371	23	IP20 chassis	595	230	242	24
11	15	46.2		96.4		463	24	IP20 chassis	595	230	242	24
15	20	59.4		96		621	24	IP20 chassis	630	308	334	35
18.5	25	74.8			97	740	33	IP20 chassis	630	308	334	35
22	30	88			97	874	33	IP20 chassis	800	370	334	50
30	40	115			97	1143	34	IP20 chassis	800	370	334	50
37	50	143			97	1400	34	IP20 chassis	315	14.57	13.15	110.2

400 Vac

Nominal motor ratings			Efficiency				Watt loss (W)	Unit size	Drive type	Height (mm)	Width (mm)	Depth (mm)	Weight (kg)
Power kW	Power HP	Current A	at 5 kHz (%)	at 4 kHz (%)	at 3 kHz (%)	at 2 kHz (%)							
0.37	1/2	1.3	93				35	12	IP20 chassis	375	90	220	5
0.75	1	2.4	96				46	12	IP20 chassis	375	90	220	5
1.5	2	4.1	97				62	12	IP20 chassis	375	90	220	5
2.2	3	5.6	97				88	12	IP20 chassis	375	90	220	5
3.7	5	10	97				124	12	IP20 chassis	375	90	220	5
5.5	7.5	13	97				187	13	IP20 chassis	375	130	220	7
7.5	10	16	97				255	13	IP20 chassis	375	130	220	7
11	15	24		98			291	23	IP20 chassis	420	165	262	12
15	20	32		98			379	23	IP20 chassis	420	165	262	12
18.5	25	37.5		98			444	24	IP20 chassis	595	230	242	24
22	30	44		98			547	24	IP20 chassis	595	230	242	24
30	40	61			98		570	24	IP20 chassis	595	230	242	24
37	50	73			98		697	33	IP20 chassis	630	308	334	35
45	60	90			98		891	33	IP20 chassis	630	308	334	35
55	75	106			98		1022	34	IP20 chassis	800	370	334	50
75	100	147			99		1232	34	IP20 chassis	800	370	334	50
90	125	177			98		2641	43	IP00 chassis	1046	407.9	374.9	91
110	150	212			98		2995	43	IP00 chassis	1046	407.9	374.9	91
132	200	260			98		3425	44	IP00 chassis	1327	407.9	374.9	138
160	250	315			98		3910	44	IP00 chassis	1327	407.9	374.9	138
200	300	395			98		4625	44	IP00 chassis	1327	407.9	374.9	138
250	350	480				98	5165	52	IP00 chassis	1547	585	497.8	313
315	450	600				98	6960	52	IP00 chassis	1547	585	497.8	313
355	500	658				98	7691	52	IP00 chassis	1547	585	497.8	313
400	550	745				98	8636	52	IP00 chassis	1547	585	497.8	313
450	600	800				98	9492	61	IP21/NEMA 1	2282	1400	606	1004
500	650	80				98	10631	61	IP21/NEMA 1	2282	1400	606	1004
560	750	990				98	11263	61	IP21/NEMA 1	2282	1400	606	1004
630	900	1120				98	13172	61	IP21/NEMA 1	2282	1400	606	1004
710	1000	1260				98	14967	62	IP21/NEMA 1	2282	1800	606	1262
800	1200	1460				98	16392	62	IP21/NEMA 1	2282	1800	606	1262

Continued on next page

General Purpose Drives

Intro

A

B

C

D

E

F

G

H

I

J/X



New



Heavy Duty efficiency, Watt loss, unit size, dimensions and weights

690 Vac

Nominal motor ratings			Efficiency			Watt Loss (W)	Unit size	Type	Height (mm)	Width (mm)	Depth (mm)	Weight (kg)
Power kW	Power HP	Current A	at 3 kHz (%)	at 2 kHz (%)	at 1.5 kHz (%)							
11	15	13	98			228	22	IP21/NEMA 1	650	242	260	27
15	20	18	98			285	22	IP21/NEMA 1	650	242	260	27
18.5	25	22	98			335	22	IP21/NEMA 1	650	242	260	27
22	30	27	98			375	22	IP21/NEMA 1	650	242	260	27
30	40	34	98			480	32	IP21/NEMA 1	770	370	335	65
37	50	41	98			592	32	IP21/NEMA 1	770	370	335	65
45	60	51	98			720	32	IP21/NEMA 1	770	370	335	65
55	75	62	98			880	32	IP21/NEMA 1	770	370	335	65
75	100	83	98			1800	32	IP21/NEMA 1	770	370	335	65
90	125	108		98		2264	43	IP00 chassis	1046	407.9	374.9	91
110	150	131		98		2664	43	IP00 chassis	1046	407.9	374.9	91
132	200	155		98		2953	43	IP00 chassis	1046	407.9	374.9	91
160	250	192		98		3451	44	IP00 chassis	1327	407.9	374.9	138
200	300	242		98		4275	44	IP00 chassis	1327	407.9	374.9	138
250	350	290		98		4875	44	IP00 chassis	1327	407.9	374.9	138
315	400	344			98	5185	44	IP00 chassis	1327	407.9	374.9	138
355	500	380			98	5385	52	IP00 chassis	1547	585	497.8	313
400	600	410			98	5818	52	IP00 chassis	1547	585	497.8	313
500	650	500			98	7671	52	IP00 chassis	1547	585	497.8	313
560	750	570			98	8715	52	IP00 chassis	1547	585	497.8	313
630	900	630	98			9674	61	IP21/NEMA 1	2282	1400	606	1004
710	1000	730	98			10965	61	IP21/NEMA 1	2282	1400	606	1004
800	1150	850	98			12890	61	IP21/NEMA 1	2282	1400	606	1004
900	1250	945	98			14457	62	IP21/NEMA 1	2282	1800	606	1262
1000	1350	1060	98			15899	62	IP21/NEMA 1	2282	1800	606	1262

AF-6 drives

Intro

A

B

C

D

E

F

G

H

I

J/X



Dimensional drawings

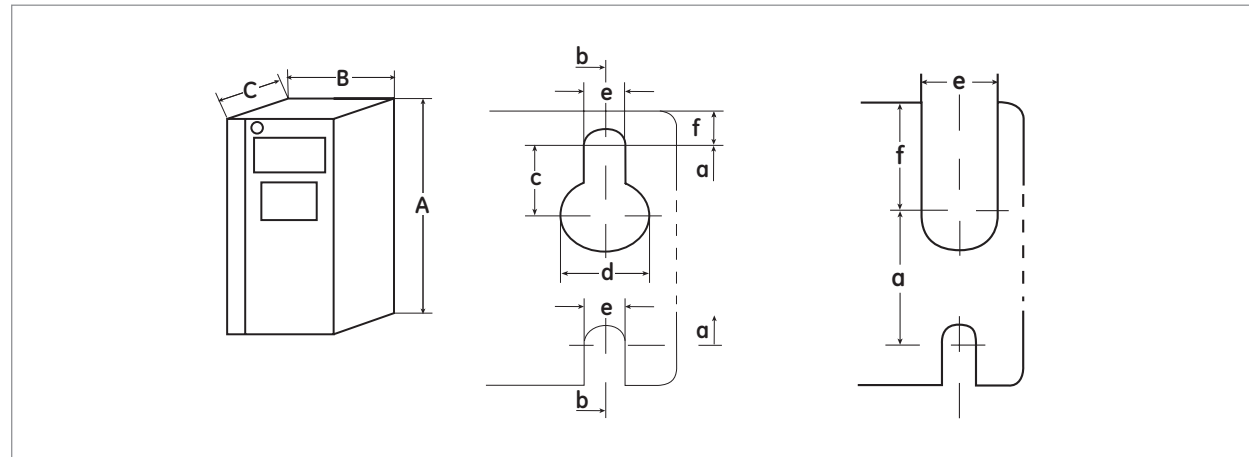

Dimensions, 1X unit sizes (mm)

Unit size		Dimensions	12	13	15
<b>Enclosure type</b>			IP20 Open chassis	IP20 Open chassis	IP55/IP66 NEMA 12/NEMA 4
<b>Voltage</b>	230V		0.25 to 2.2kW 1/3 to 3HP	3.7kW 5HP	0.25 to 3.7kW 1/3 to 5HP
	400V		0.37 to 3.7kW 1/2 to 5HP	5.5 to 7.5kW 7.5 to 10HP	0.37 to 7.5kW 1/2 to 10HP
<b>Height</b>	Height of backplate	A	268	268	420
	Height with de-coupling plate	A	375	375	
	Distance between mounting holes	a	257	257	402
<b>Width</b>	Width of backplate	B	90	130	242
	Distance between mounting holes	b	70	110	215
<b>Depth</b>	Depth without I/O and/or network option	C	205	205	195
	Depth with I/O and/or network option	C	220	220	195
<b>Screw holes</b>		c	8.0	8.0	8.3
		d	11.0	11.0	12.0
		e	5.5	5.5	6.5
		f	9.0	9.0	9.0
<b>Weight (kg)</b>			4.9	6.6	13.5 / 14.2

Dimensions, 2X unit sizes (mm)

Unit size		Dimensions	21	22	23	24
<b>Enclosure type</b>			IP55/IP66 NEMA 12/NEMA 4	IP55/IP66 NEMA 12/NEMA 4	IP20 Open chassis	IP20 Open chassis
<b>Voltage</b>	230V		5.5 to 7.5kW 7.5 to 10HP	11kW 15HP	5.5 to 7.5kW 7.5 to 10HP	11 to 15kW 15 to 20HP
	400V		11 to 15kW 15 to 20HP	18.5 to 22kW 25 to 30HP	11 to 15kW 15 to 20HP	18.5 to 30kW 25 to 40HP
<b>Height</b>	Height of backplate	A	480	650	399	521
	Height with de-coupling plate	A	-	-	420	595
	Distance between mounting holes	a	455	625	380	495
<b>Width</b>	Width of backplate	B	242	242	165	230
	Distance between mounting holes	b	210	210	140	200
<b>Depth</b>	Depth without I/O and/or network option	C	260	260	249	242
	Depth with I/O and/or network option	C	260	260	262	242
<b>Screw holes</b>		c	12.0	12.0	8.0	-
		d	19.0	19.0	12.0	-
		e	9.0	9.0	6.8	8.5
		f	9.0	9.0	7.9	15.0
<b>Weight (kg)</b>			23.0	27.0	12.0	23.5

General Purpose Drives

Intro

A

B

C

D

E

F

G

H

I

J/X



New

Dimensional drawings

Dimensions, 3X unit sizes (mm)

Unit size		Dimensions	31	32	33	34
<b>Enclosure type</b>			IP55/IP66	IP55/IP66	IP20	IP20
			NEMA 12/NEMA 4	NEMA 12/NEMA 4	Open chassis	Open chassis
<b>Voltage</b>	230V		15 to 22kW 20 to 30HP	30 to 37kW 40 to 50HP	18.5 to 22kW 25 to 30HP	30 to 37kW 40 to 50HP
	400V		30 to 45kW 40 to 60HP	55 to 75kW 75 to 100HP	37 to 45kW 50 to 60HP	55 to 75kW 75 to 100HP
<b>Height</b>	Height of backplate	A	680	770	550	660
	Height with de-coupling plate	A	-	-	630	800
	Distance between mounting holes	a	648	739	521	631
<b>Width</b>	Width of backplate	B	308	370	308	370
	Distance between mounting holes	b	272	334	270	330
<b>Depth</b>	Depth without I/O and/or network option	C	310	335	333	333
	Depth with I/O and/or network option	C	310	335	333	333
<b>Screw holes</b>		c	12.5	12.5	-	-
		d	19.0	19.0	-	-
		e	9.0	9.0	8.5	8.5
		f	9.8	9.8	17.0	17.0
<b>Weight (kg)</b>			45	65	35	50

Dimensions IP20 open chassis drives with field installed IP21/NEMA 1 kits<sup>(1)</sup> (mm)

Unit Size	12	13	23	24	33	34
<b>Enclosure type</b>	IP20 open chassis with IP21/NEMA 1 kit					
<b>Voltage</b>	230V					
	0.25 to 2.2kW 1/3 to 3HP	3.7kW 5HP	5.5 to 7.5kW 7.5 to 10HP	11 to 15kW 15 to 20HP	18.5 to 22kW 25 to 30HP	30 to 37kW 40 to 50HP
<b>400V</b>	0.25 to 2.2kW 1/2 to 5HP					
	0.25 to 2.2kW 1/2 to 5HP	5.5 to 7.5kW 7.5 to 10HP	11 to 15kW 15 to 20HP	18.5 to 30kW 25 to 40HP	37 to 45kW 50 to 60HP	55 to 75kW 75 to 100HP
<b>Height</b>	Height with kit					
	375	375	475	671	754	950
<b>Width</b>	Width of backplate					
	94	130	165	231	397	371
	Distance between mounting holes					
	70	110	140	201	269	330
<b>Depth</b>	Depth without I/O and/or network option					
	205	205	249	242	338	338
	Depth with I/O and/or network option					
	220	220	262	242	338	338

(1) Please consult IP21/NEMA 1 kit Instructions for further mounting details and dimensions.

Note: please allow 5cm / 2" between drives with field installed IP21/NEMA 1 kits. Also, please consult the relevant AF-6 Series drives operating instructions for recommended clearance above and below each drive rating.

AF-6 drives

Intro

A

B

C

D

E

F

G

H

I

J/X



New

Dimensional drawings in mm (inches)

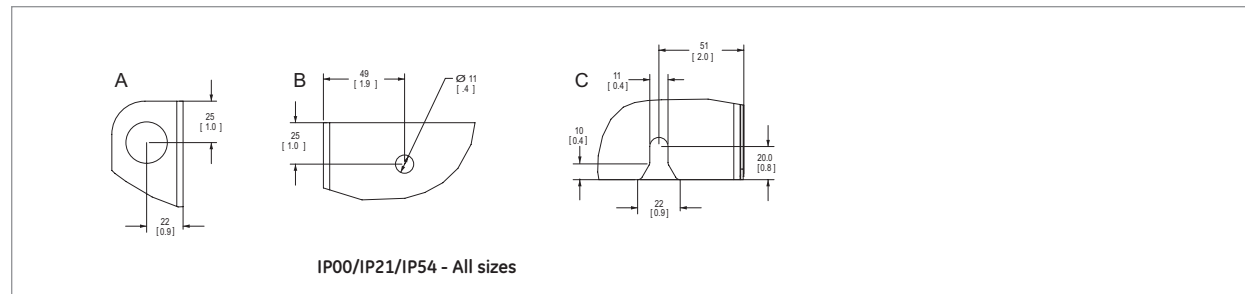
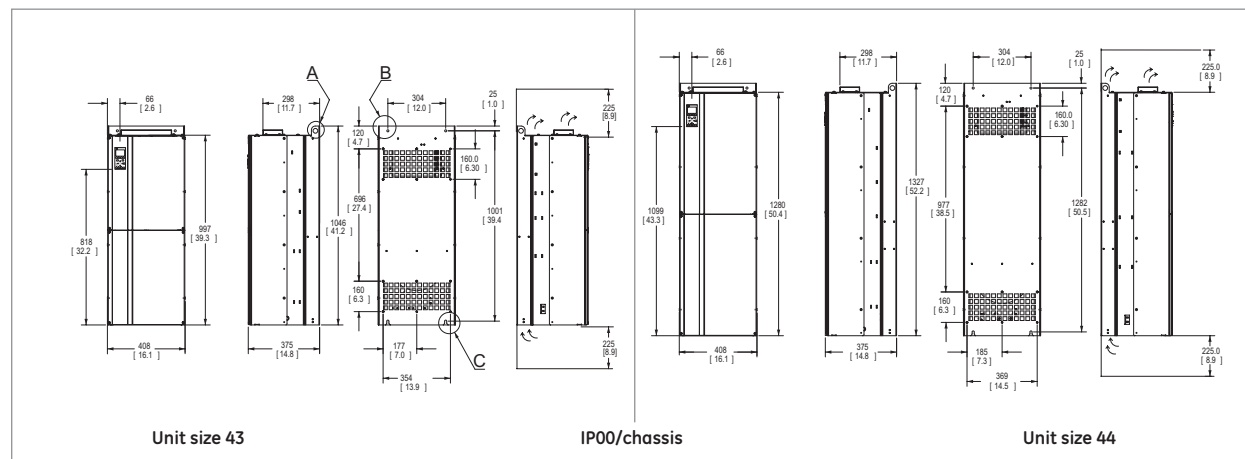
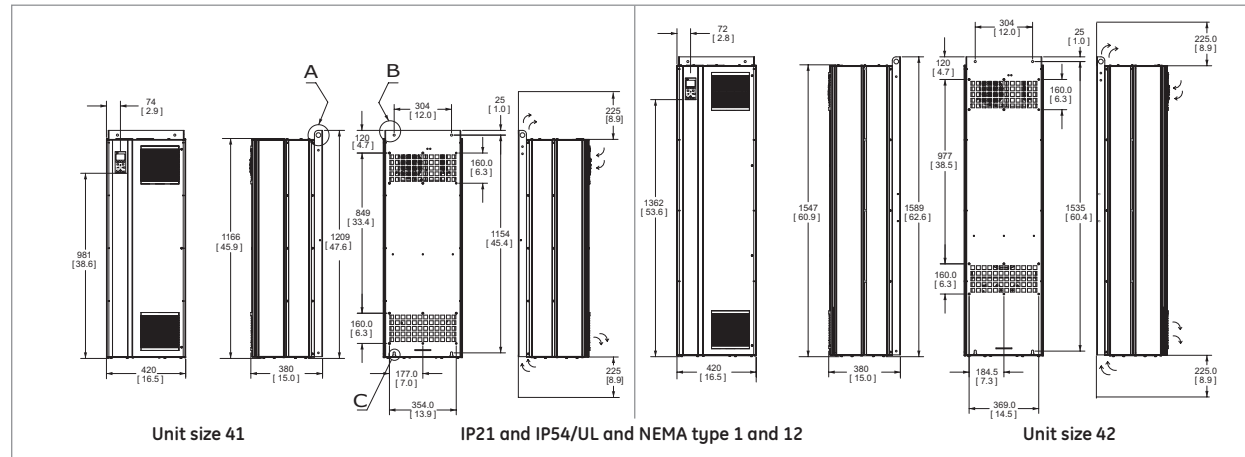

Unit size	41	42	43	44
Enclosure type	IP21/IP54 NEMA 1/NEMA 12	IP21/IP54 NEMA 1/NEMA 12	IP00 Open chassis	IP00 Open chassis
Voltage	400V	90 to 110kW 125 to 150HP	90 to 110kW 125 to 150HP	132 to 200kW 200 to 300HP
	690V	90 to 132kW 125 to 200HP	160 to 315kW 250 to 400HP	15 to 22kW 125 to 200HP
Shipping dimensions	Height	650	650	650
	Width	1730	1730	1220
	Depth	570	570	570
Drive dimensions	Height	1209	1589	1046
	Width	420	420	408
	Depth	380	380	375
Weight (kg)	104	106	91	138

General Purpose Drives

Intro

A

B

C

D

E

F

G

H

I

J/X



New

Dimensional drawings in mm (inches)

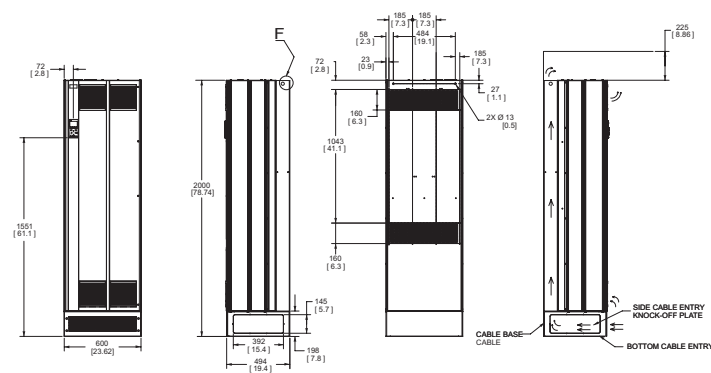

Unit size 51, IP21 and IP54/UL and NEMA type 1 and 12

Unit size 51

Enclosure type	IP21/IP54 NEMA 1/NEMA 12
Voltage	400V 250 to 400kW 350 to 550HP
	690V 355 to 560kW 500 to 750HP
<b>Shipping dimensions</b>	
Height	841
Width	2197
Depth	734
<b>Drive dimensions</b>	
Height	2000
Width	600
Depth	494
Weight (kg)	313

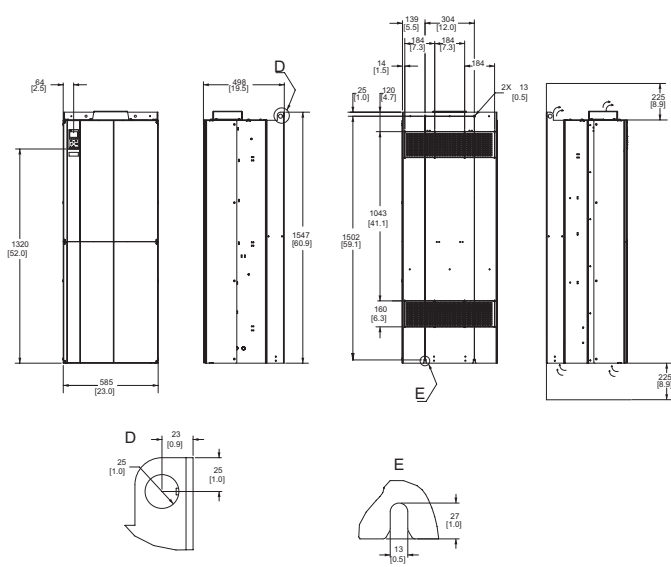

Unit size 52, IP00/Chassis

Unit size 52

Enclosure type	IP00 Open chassis
Voltage	400V 250 to 400kW 350 to 550HP
	690V 355 to 560kW 500 to 750HP
<b>Shipping dimensions</b>	
Height	831
Width	1704
Depth	734
<b>Drive dimensions</b>	
Height	1547
Width	585
Depth	498
Weight (kg)	313

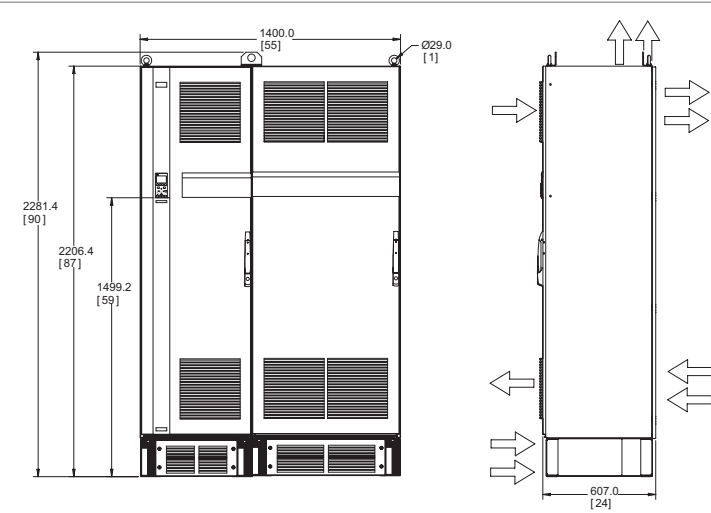

Unit Size 61

Unit size 61

Enclosure type	IP21/IP54 NEMA 1/NEMA 12
Voltage	400V 450 to 630kW 600 to 900HP
	690V 630 to 800kW 900 to 1150HP
<b>Shipping dimensions</b>	
Height	2324
Width	1570
Depth	927
<b>Drive dimensions</b>	
Height	2282
Width	1400
Depth	606
Weight (kg)	1004

Dimensional drawings in mm (inches)

**Unit size 62**

<b>Enclosure type</b>	IP21/IP55 NEMA 1/NEMA 12
<b>Voltage</b>	400V 710 to 800kW 1000 to 1200HP 690V 900 to 1000kW 1250 to 1350HP
<b>Shipping dimensions</b>	Height 2324 Width 1961 Depth 419
<b>Drive dimensions</b>	Height 2282 Width 1800 Depth 606
<b>Weight (kg)</b>	1262

**Unit size 63**

<b>Enclosure type</b>	IP21/IP55 NEMA 1/NEMA 12
<b>Voltage</b>	400V 450 to 630kW 600 to 900HP 690V 630 to 800kW 900 to 1150HP
<b>Shipping dimensions</b>	Height 2324 Width 2159 Depth 927
<b>Drive dimensions</b>	Height 2282 Width 2000 Depth 606
<b>Weight (kg)</b>	1300

**Unit size 64**

<b>Enclosure type</b>	IP21/IP55 NEMA 1/NEMA 12
<b>Voltage</b>	400V 710 to 800kW 1000 to 1200HP 690V 900 to 1000kW 1250 to 1350HP
<b>Shipping dimensions</b>	Height 2324 Width 2543 Depth 927
<b>Drive dimensions</b>	Height 2282 Width 2400 Depth 606
<b>Weight (kg)</b>	1541

General Purpose Drives

Intro

A

B

C

D

E

F

G

H

I

J/X



New



## AF-600 FP - Fan and Pump Drives

The AF-600 FP Fan and Pump Drive is a powerful, flexible and easy to use AC variable torque drive.

The drive is available in its standard configuration that includes LCD keypad display that can be remote mounted, DC link reactors, built-in Modbus RTU, Metasys N2, Apogee FLN P1 and RFI Class A2 filter. Available in IP55 enclosure.

Following models are available:

- Three-phase, 230Vac, from 1.1 to 45kW, 1 to 60HP
- Three-phase, 400Vac, from 1.1 to 1000kW, 1 to 1350HP
- Three-phase, 690Vac, from 1.1 to 1000kW, 1 to 1350HP

### Features

All features HVAC needs

- RFI class A2 filter and DC link reactor as standard configuration.
- Built-in communication networks for ModBus RTU, Metasys N2 and Apogee FLN P1
- Field installed network options: BACnet, LonWorks, Profibus DP, Profinet, Modbus TCP/IP, Ethernet/IP and DeviceNet
- 110% current overload for 1 minute (Light Duty)
- Hot pluggable, illuminated LCD display, unit indications, rotation direction indication, trended charts display speed, torque, current, full alarm messages & descriptions
- 4 auto-tuning PID controllers
- Integrated logic control, PLC
- "Pick up" start (catch a spinning motor)
- Easy to use PC software
- Energy monitoring feature
- Flow compensation
- Pump cascade controller
- Sleep mode
- Fan belt monitoring
- Stairwell pressurization
- Fire override mode
- High standard protection Class 3C2, optional class 3C3

### Approvals / Marking



UL, cUL, C-Tick

### Applications

#### Fan

HVAC, cooling towers, VAV, supply and return, exhaust, fume hood, make-up air, induced and forced draft, furnace temperature control.

#### Pump

Chilled water, pressure boosting, cooling tower, wastewater, chiller, irrigation, hydro-storage.

### Product numbering system diagram

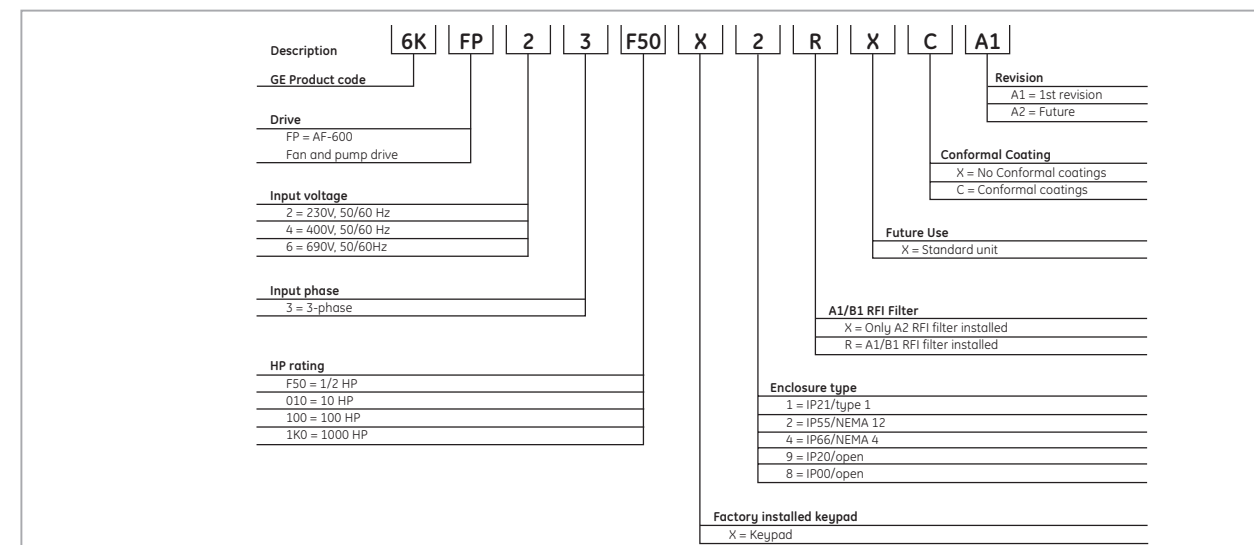

Product number for illustrative purposes only



IP00 / IP20 / IP21, with EMC filter Class A2, without braking chopper  
230V, 3-phase, 50/60Hz input

Nominal motor ratings				Enclosure type <sup>(2)</sup> :	Cat. No.	Ref. No.	Unit size
Power kW	Power HP	Current A	Overload current (A) (110% 1 Min)				
0.75	1	4.6	5.1	IP20	6KFP23001X9XXXXA1	404684	12
1.5	2	7.5	8.3		6KFP23002X9XXXXA1	404685	12
2.2	3	10.6	11.7		6KFP23003X9XXXXA1	404686	12
3.7	5	16.7	18.4		6KFP23005X9XXXXA1	404687	13
5.5	7.5	24.2	26.6		6KFP23007X9XXXXA1	404688	23
7.5	10	30.8	33.9		6KFP23010X9XXXXA1	404689	23
11	15	46.2	50.8		6KFP23015X9XXXXA1	404690	23
15	20	59.4	65.3		6KFP23020X9XXXXA1	404691	24
18.5	25	74.8	82.3		6KFP23025X9XXXXA1	404692	24
22	30	88	96.8		6KFP23030X9XXXXA1	404693	33
30	40	115	126.5		6KFP23040X9XXXXA1	404694	33
37	50	143	157		6KFP23050X9XXXXA1	404695	34
45	60	170	187		6KFP23060X9XXXXA1	404696	34

400V, 3-phase, 50/60Hz input

Nominal motor ratings				Enclosure type <sup>(2)</sup> :	Cat. No.	Ref. No.	Unit size	
Power kW	Power HP	Current A	Overload current (A) (110% 1 Min)					
0.75	1	1.3	1.43	IP20	6KFP43001X9XXXXA1	403855	12	
1.5	2	2.4	2.64		6KFP43002X9XXXXA1	403856	12	
2.2	3	4.1	4.51		6KFP43003X9XXXXA1	403857	12	
4	5	5.6	6.16		6KFP43005X9XXXXA1	403858	12	
5.5	7.5	10	11		6KFP43007X9XXXXA1	403859	13	
7.5	10	13	14.3		6KFP43010X9XXXXA1	403860	13	
11	15	16	17.6		6KFP43015X9XXXXA1	403861	23	
15	20	32	35.2		6KFP43020X9XXXXA1	403862	23	
18.5	25	37.5	41.25		6KFP43025X9XXXXA1	403863	23	
22	30	44	48.4		6KFP43030X9XXXXA1	403864	24	
30	40	61	67.1		6KFP43040X9XXXXA1	403865	24	
37	50	73	80.3		6KFP43050X9XXXXA1	403866	24	
45	60	90	99		6KFP43060X9XXXXA1	403867	33	
55	75	106	116.6		6KFP43075X9XXXXA1	403868	33	
75	100	147	161.7		6KFP43100X9XXXXA1	403869	34	
90	125	177	194.7		6KFP43125X9XXXXA1	403870	34	
110	150	212	233.2	IP00	6KFP43150X8XXXXA1	403871	43	
132	200	260	286		6KFP43200X8XXXXA1	403872	43	
160	250	315	346.5		6KFP43250X8XXXXA1	403873	44	
200	300	395	434.5		6KFP43300X8XXXXA1	403874	44	
250	350	480	528		6KFP43350X8XXXXA1	403875	44	
315	450	600	660		IP00 conformal coated	6KFP43450X8XXCA1	403876	52
355	500	658	723.8			6KFP43500X8XXCA1	403877	52
400	550	745	819.5			6KFP43550X8XXCA1	403878	52
450	600	800	880			6KFP43600X8XXCA1	403879	52
500	650	880	968		IP21/NEMA 1 conformal coated	6KFP43650X1XXCA1	403880	61
560	750	990	1089	6KFP43750X1XXCA1		403881	61	
630	900	1120	1232	6KFP43900X1XXCA1		403882	61	
710	1000	1260	1386	6KFP431K0X1XXCA1		403883	61	
800	1200	1460	1606	6KFP431K2X1XXCA1		403884	62	
1000	1350	1700	1870	6KFP431K3X1XXCA1		403885	62	

690V, 3-phase, 50/60Hz input

Nominal motor ratings				Enclosure type <sup>(2)</sup> :	Cat. No.	Ref. No.	Unit size			
Power kW	Power HP	Current A	Overload current (A) (110% 1 Min)							
11	15	13	14	IP21/NEMA 1	6KFP63015X1XXCA1	on request				
15	20	18	20		6KFP63020X1XXCA1					
18.5	25	22	24		6KFP63025X1XXCA1					
22	30	27	30		6KFP63030X1XXCA1					
30	40	34	37		6KFP63040X1XXCA1					
37	50	41	45		6KFP63050X1XXCA1					
45	60	52	57		6KFP63060X1XXCA1					
55	75	62	68		6KFP63075X1XXCA1					
75	100	83	91		6KFP63100X1XXCA1					
90	125	100	110		6KFP63125X1XXCA1					
110	150	131	144		6KFP63150X8XXCA1					
132	200	155	171		6KFP63200X8XXCA1					
160	250	192	211		6KFP63250X8XXCA1					
200	300	242	266		IP00 conformal coated			6KFP63300X8XXCA1	on request	
250	350	290	319					6KFP63350X8XXCA1		
315	400	344	378					6KFP63450X8XXCA1		
355	500	400	440	6KFP63550X8XXCA1						
400	550	450	495	6KFP63600X8XXCA1						
500	650	500	550	6KFP63650X8XXCA1						
560	750	570	627	6KFP63750X8XXCA1						
630	900	630	693	6KFP63900X8XXCA1						
710	1000	730	803	IP21/NEMA 1 conformal coated	6KFP631K0X1XXCA1					
800	1150	850	935		6KFP631K1X1XXCA1					
900	1250	945	1040		6KFP631K2X1XXCA1					
1000	1350	1060	1166		6KFP631K3X1XXCA1					
1200	1600	1260	1386		6KFP631K6X1XXCA1					
1400	1900	1415	1557		6KFP631K9X1XXCA1					

(1) Drives are rated NEMA 1 without the need for a separate kit.

(2) IP21/NEMA 1 kits are available as field installed options for all 230V drives from 1.1 to 45kW / 1 to 60HP and for all 400V drives from 1.1 to 90kW / 1 to 125HP. See page H.51.

Fan and Pump Drives

Intro

A

B

C

D

E

F

G

H

I

J/X



New



**IP54 / IP55, with EMC filter Class A2, without Braking Chopper**  
**230V, 3-phase, 50/60Hz input**

Nominal motor ratings				Enclosure type <sup>(1)</sup> :	Cat. No.	Ref. No.	Unit size
Power kW	Power HP	Current A	Overload current (A) (110% 1 Min)				
0.75	1	4.6	5.1	IP55/NEMA 12	6KFP23001X2XXXA1	404697	12
1.5	2	7.5	8.3		6KFP23002X2XXXA1	404698	12
2.2	3	10.6	11.7		6KFP23003X2XXXA1	404699	12
3.7	5	16.7	18.4		6KFP23005X2XXXA1	404700	13
5.5	7.5	24.2	26.6		6KFP23007X2XXXA1	404701	23
7.5	10	30.8	33.9		6KFP23010X2XXXA1	404702	23
11	15	46.2	50.8		6KFP23015X2XXXA1	404703	23
15	20	59.4	65.3		6KFP23020X2XXXA1	404704	24
18.5	25	74.8	82.3		6KFP23025X2XXXA1	404705	24
22	30	88	96.8		6KFP23030X2XXXA1	404706	33
30	40	115	126.5		6KFP23040X2XXXA1	404707	33
37	50	143	157		6KFP23050X2XXXA1	404708	34
45	60	170	187		6KFP23060X2XXXA1	404709	34

**400V, 3-phase, 50/60Hz input**

Nominal motor ratings				Enclosure type <sup>(1)</sup> :	Cat. No.	Ref. No.	Unit size
Power kW	Power HP	Current A	Overload current (A) (110% 1 Min)				
0.75	1	1.3	1.43	IP55/NEMA 12	6KFP43001X2XXXA1	403886	12
1.5	2	2.4	2.64		6KFP43002X2XXXA1	403887	12
2.2	3	4.1	4.51		6KFP43003X2XXXA1	403888	12
4	5	5.6	6.16		6KFP43005X2XXXA1	403889	12
5.5	7.5	10	11		6KFP43007X2XXXA1	403890	13
7.5	10	13	14.3		6KFP43010X2XXXA1	403891	13
11	15	16	17.6		6KFP43015X2XXXA1	403892	23
15	20	32	35.2		6KFP43020X2XXXA1	403893	23
18.5	25	37.5	41.25		6KFP43025X2XXXA1	403894	23
22	30	44	48.4		6KFP43030X2XXXA1	403895	24
30	40	61	67.1		6KFP43040X2XXXA1	403896	24
37	50	73	80.3		6KFP43050X2XXXA1	403897	24
45	60	90	99		6KFP43060X2XXXA1	403898	33
55	75	106	116.6		6KFP43075X2XXXA1	403899	33
75	100	147	161.7		6KFP43100X2XXXA1	403900	34
90	125	177	194.7		6KFP43125X2XXXA1	403901	34
110	150	212	233.2	6KFP43150X2XXXA1	403902	43	
132	200	260	286	6KFP43200X2XXXA1	403903	43	
160	250	315	346.5	6KFP43250X2XXXA1	403904	44	
200	300	395	434.5	6KFP43300X2XXXA1	403905	44	
250	350	480	528	6KFP43350X2XXXA1	403906	44	
315	450	600	660	6KFP43450X2XXXA1	403907	52	
355	500	658	723.8	6KFP43500X2XXXA1	403908	52	
400	550	745	819.5	6KFP43550X2XXXA1	403909	52	
450	600	800	880	6KFP43600X2XXXA1	403910	52	
500	650	880	968	6KFP43650X2XXXA1	403911	61	
560	750	990	1089	6KFP43750X2XXXA1	403912	61	
630	900	1120	1232	6KFP43900X2XXXA1	403913	61	
710	1000	1260	1386	6KFP431K0X2XXXA1	403914	61	
800	1200	1460	1606	6KFP431K2X2XXXA1	403915	62	
1000	1350	1700	1870	6KFP431K3X2XXXA1	403916	62	

**690V, 3-phase, 50/60Hz input**

Nominal motor ratings				Enclosure type <sup>(1)</sup> :	Cat. No.	Ref. No.	Unit size
Power kW	Power HP	Current A	Overload current (A) (110% 1 Min)				
15	20	18	20	IP55/NEMA 12 conformal coated	6KFP63015X2XXXA1	on request	
18.5	25	22	24		6KFP63020X2XXXA1		
22	30	27	30		6KFP63025X2XXXA1		
30	40	34	37		6KFP63030X2XXXA1		
37	50	41	45		6KFP63040X2XXXA1		
45	60	52	57		6KFP63050X2XXXA1		
55	75	62	68		6KFP63060X2XXXA1		
75	100	83	91		6KFP63075X2XXXA1		
90	125	100	110		6KFP63100X2XXXA1		
110	150	131	144		6KFP63125X2XXXA1		
132	200	155	171		6KFP63150X2XXXA1		
160	250	192	211		6KFP63200X2XXXA1		
200	300	242	266		6KFP63250X2XXXA1		
250	350	290	319		6KFP63300X2XXXA1		
315	400	344	378		6KFP63350X2XXXA1		
355	500	400	440		6KFP63400X2XXXA1		
400	550	450	495	6KFP63500X2XXXA1			
500	650	500	550	6KFP63550X2XXXA1			
560	750	570	627	6KFP63650X2XXXA1			
630	900	630	693	6KFP63750X2XXXA1			
710	1000	730	803	6KFP63900X2XXXA1			
800	1150	850	935	6KFP631K0X2XXXA1			
900	1250	945	1040	6KFP631K1X2XXXA1			
1000	1350	1060	1166	6KFP631K2X2XXXA1			
1200	1600	1260	1386	6KFP631K3X2XXXA1			
1400	1900	1415	1557	6KFP631K6X2XXXA1			

(1) Drives are rated NEMA 1 without the need for a separate kit.  
 (2) IP21/NEMA 1 kits are available as field installed options for all 230V drives from 1.1 to 45kW / 1 to 60HP and for all 400V drives from 1.1 to 90kW / 1 to 125HP. See page H.51.

AF-6 drives  
Intro  
A  
B  
C  
D  
E  
F  
G  
H  
I  
J/X

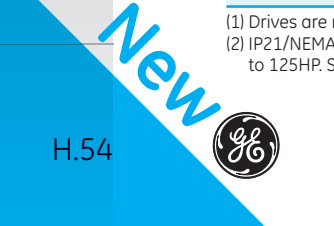

**IP66, with EMC filter Class A2, without braking chopper**

**230V, 3-phase, 50/60Hz input**

Nominal motor ratings				Enclosure type <sup>[2]</sup> :	Cat. No.	Ref. No.	Unit size
Power kW	Power HP	Current A	Overload current (A) (110% 1 Min)				
0.75	1	4.6	5.1	IP66/NEMA 12	6KFP23001X4XXXA1	on request	
1.5	2	7.5	8.3		6KFP23002X4XXXA1		
2.2	3	10.6	11.7		6KFP23003X4XXXA1		
3.7	5	16.7	18.4		6KFP23005X4XXXA1		
5.5	7.5	24.2	26.6		6KFP23007X4XXXA1		
7.5	10	30.8	33.9		6KFP23010X4XXXA1		
11	15	46.2	50.8		6KFP23015X4XXXA1		
15	20	59.4	65.3		6KFP23020X4XXXA1		
18.5	25	74.8	82.3		6KFP23025X4XXXA1		
22	30	88	96.8		6KFP23030X4XXXA1		
30	40	115	126.5		6KFP23040X4XXXA1		
37	50	143	157		6KFP23050X4XXXA1		
45	60	170	187		6KFP23060X4XXXA1		

**400V, 3-phase, 50/60Hz input**

Nominal motor ratings				Enclosure type <sup>[2]</sup> :	Cat. No.	Ref. No.	Unit size
Power kW	Power HP	Current A	Overload current (A) (110% 1 Min)				
0.75	1	1.3	1.43	IP66/NEMA 12	6KFP43001X4XXXA1	on request	
1.5	2	2.4	2.64		6KFP43002X4XXXA1		
2.2	3	4.1	4.51		6KFP43003X4XXXA1		
4	5	5.6	6.16		6KFP43005X4XXXA1		
5.5	7.5	10	11		6KFP43007X4XXXA1		
7.5	10	13	14.3		6KFP43010X4XXXA1		
11	15	16	17.6		6KFP43015X4XXXA1		
15	20	32	35.2		6KFP43020X4XXXA1		
18.5	25	37.5	41.25		6KFP43025X4XXXA1		
22	30	44	48.4		6KFP43030X4XXXA1		
30	40	61	67.1		6KFP43040X4XXXA1		
37	50	73	80.3		6KFP43050X4XXXA1		
45	60	90	99		6KFP43060X4XXXA1		
55	75	106	116.6		6KFP43075X4XXXA1		
75	100	147	161.7		6KFP43100X4XXXA1		
90	125	177	194.7		6KFP43125X4XXXA1		
110	150	212	233.2	6KFP43150X4XXXA1			
132	200	260	286	6KFP43200X4XXXA1			
160	250	315	346.5	6KFP43250X4XXXA1			
200	300	395	434.5	6KFP43300X4XXXA1			
250	350	480	528	6KFP43350X4XXXA1			
315	450	600	660	6KFP43450X4XXCA1			
355	500	658	723.8	6KFP43500X4XXCA1			
400	550	745	819.5	6KFP43550X4XXCA1			
450	600	800	880	6KFP43600X4XXCA1			
500	650	880	968	6KFP43650X4XXCA1			
560	750	990	1089	6KFP43750X4XXCA1			
630	900	1120	1232	6KFP43900X4XXCA1			
710	1000	1260	1386	6KFP431K0X4XXCA1			
800	1200	1460	1606	6KFP431K2X4XXCA1			
1000	1350	1700	1870	6KFP431K3X4XXCA1			

[1] Drives are rated NEMA 1 without the need for a separate kit.

[2] IP21/NEMA 1 kits are available as field installed options for all 230V drives from 1.1 to 45kW / 1 to 60HP and for all 400V drives from 1.1 to 90kW / 1 to 125HP. See page H.51.

Fan and Pump Drives

Intro

A

B

C

D

E

F

G

H

I

J/X



New

Options and accessories

Field installed IP21/NEMA 1 add-on option kits



Voltage	Power kW	Power HP	IP21/NEMA 1 kit Cat. No.	Ref. No.
230	0,75	1	NEMA1ACA2	404831
	1.5	2	NEMA1ACA2	404831
	2.2	3	NEMA1ACA2	404831
	3.7	5	NEMA1ACA3	404832
	5.5	7.5	NEMA1ACB3	404833
	7.5	10	NEMA1ACB3	404833
	11	15	NEMA1ACB3	404833
	15	20	NEMA1ACB4	404834
	18.5	25	NEMA1ACB4	404834
	22	30	NEMA1ACC3	404835
	30	40	NEMA1ACC3	404835
	37	50	NEMA1ACC4	404836
45	60	NEMA1ACC4	404836	
400	0,75	1	NEMA1ACA2	404831
	1.5	2	NEMA1ACA2	404831
	2.2	3	NEMA1ACA2	404831
	3.7	5	NEMA1ACA2	404831
	5.5	7.5	NEMA1ACA3	404832
	7.5	10	NEMA1ACA3	404832
	11	15	NEMA1ACB3	404833
	15	20	NEMA1ACB3	404833
	18.5	25	NEMA1ACB3	404833
	22	30	NEMA1ACB4	404834
	30	40	NEMA1ACB4	404834
	37	50	NEMA1ACB4	404834
	45	60	NEMA1ACC3	404835
	55	75	NEMA1ACC3	404835
	75	100	NEMA1ACC4	404836
90	125	NEMA1ACC4	404836	

Remote mounting kit for graphical LCD keypad

Remote mounting Kit for mounting graphical LCD Keypad on enclosure door. Kit includes gasket, mounting brackets, and cable. Keypad is rated IP65.



Description	Cat. No.	Ref. No.
Remote mounting kit for graphical LCD keypad	RMKYPDAC	404851
Remote mounting kit without cable	OPCRMKNC	404850

Communications modules



Module Name	Description	Cat. No.	Ref. No.
<b>Profibus DP communications module</b>	Profibus DP internal drive mounted module for use on AF-650 GP and AF-600 FP drives. Supports Profibus DP V1 communications networks.	OPCPDP	404848
<b>DeviceNet communications module</b>	DeviceNet internal drive mounted module for use on AF-650 GP and AF-600 FP drives. ODVA certified device.	OPCDEV	404818
<b>Ethernet IP communications module(1)</b>	Ethernet IP internal drive mounted module for use on AF-650 GP and AF-600 FP drives. ODVA certified device. Features 2-port built-in switch. Also includes webserver and e-mail notification.	OPCEIP	404820
<b>Modbus TCP communications module</b>	Modbus TCP internal drive mounted module for use on AF-650 GP and AF-600 FP drives.	OPCMBTCP	404824
<b>ProfiNet RT communications module</b>	ProfiNet RT internal drive mounted module for use on AF-650 GP and AF-600 FP drives.	OPCPRT	404825
<b>LonWorks communications module</b>	LonWorks internal drive mounted module for use on AF-600 FP drives only. Supports LonWorks building automation communications networks.	OPCLON	404823
<b>BacNet communications module</b>	BacNet internal drive mounted module for use on AF-60 FP drives only. Supports BacNet MSTP building automation communications networks.	OPCBAC	404817

(1) Requires I/O and network slots and cannot be used with any other network or I/O modules.

AF-6 drives  
Intro  
A  
B  
C  
D  
E  
F  
G  
H  
I  
J/X

Options and accessories (continued)

**Relay output module**



Relay output internal drive mounted module for use on AF-600 drives. Module adds (3) Form C relay outputs to the drive. Relays are rated at 2A at 240V resistive load.

Description	Cat. No.	Ref. No.
Relay output module	OPCRLY	404849

**Analog I/O module**

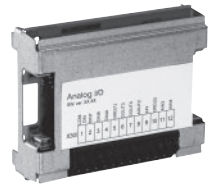

Analog I/O internal drive mounted module for use on the AF-600 FP drive only. Module includes: 3) Analogue inputs 0-10V, 0/4-20mA  
3) Analogue outputs 0-10V  
Battery back-up power for AF-600 FP's internal real time clock

Analog I/O module	OPCAIO	404816
-------------------	--------	--------

**24V DC external supply module**



24V DC external supply internal drive mounted module for use on AF-600 FP drives. This module accepts an external 24V DC supply which is used to keep the control board of the drive and other option modules powered in the event of a line side power outage. Can be used with communications and I/O modules.

24V DC external supply module	OPC24VPS	404815
-------------------------------	----------	--------

**General purpose I/O module**



General purpose I/O internal drive mounted module for use on AF-600 FP drives. Module includes: 3x digital inputs 24V  
2x digital outputs PNP/NPN  
2x analogue inputs 0-10V  
1x analogue output 0/4-20mA

General purpose I/O module	OPCGPIO	404821
----------------------------	---------	--------

**Screw terminal accessory**



Screw terminal accessory is available for field installation on AF-600 FP drives. These screw terminals can replace the cage clamp terminals which ship with each drive. This set of three terminals are for the digital inputs, analog I/O, and RS485 connection.

Screw terminal accessory	OPCSTERM	404822
--------------------------	----------	--------

Micro Drives

Intro

A

B

C

D

E

F

G

H

I

J/X



New

Options and accessories (continued)



**Pedestal kit**

Pedestal kit allows Unit Size 41 and 42 drives to be floor mounted (IP21/54/55, NEMA 1 and 12, 110 to 250/315kW / 150 to 350/400HP at 400V for AF-600 FP).

Description	Cat. No.	Ref. No.
Pedestal kit	OPC4XPED	404845



**USB kit**

This kit allows for the USB programming terminal to be brought out to the front cover of the drive. Works with all drive types.

Description	Cat. No.	Ref. No.
For all drives up to unit size 5X	OPCUSB	404861
For all unit size 6X drives	OPCUSB6X	404860

**Power shields**

These shields are used to cover the drive power terminals on NEMA 1 and NEMA 12 drive types.

For unit size 41 and 42 drives	OPCCOVER4142	404846
For unit size 51 drives	OPCCOVER51	404847

AF-6 drives

Intro

A

B

C

D

E

F

G

H

I

J/X

Basic wiring diagrams

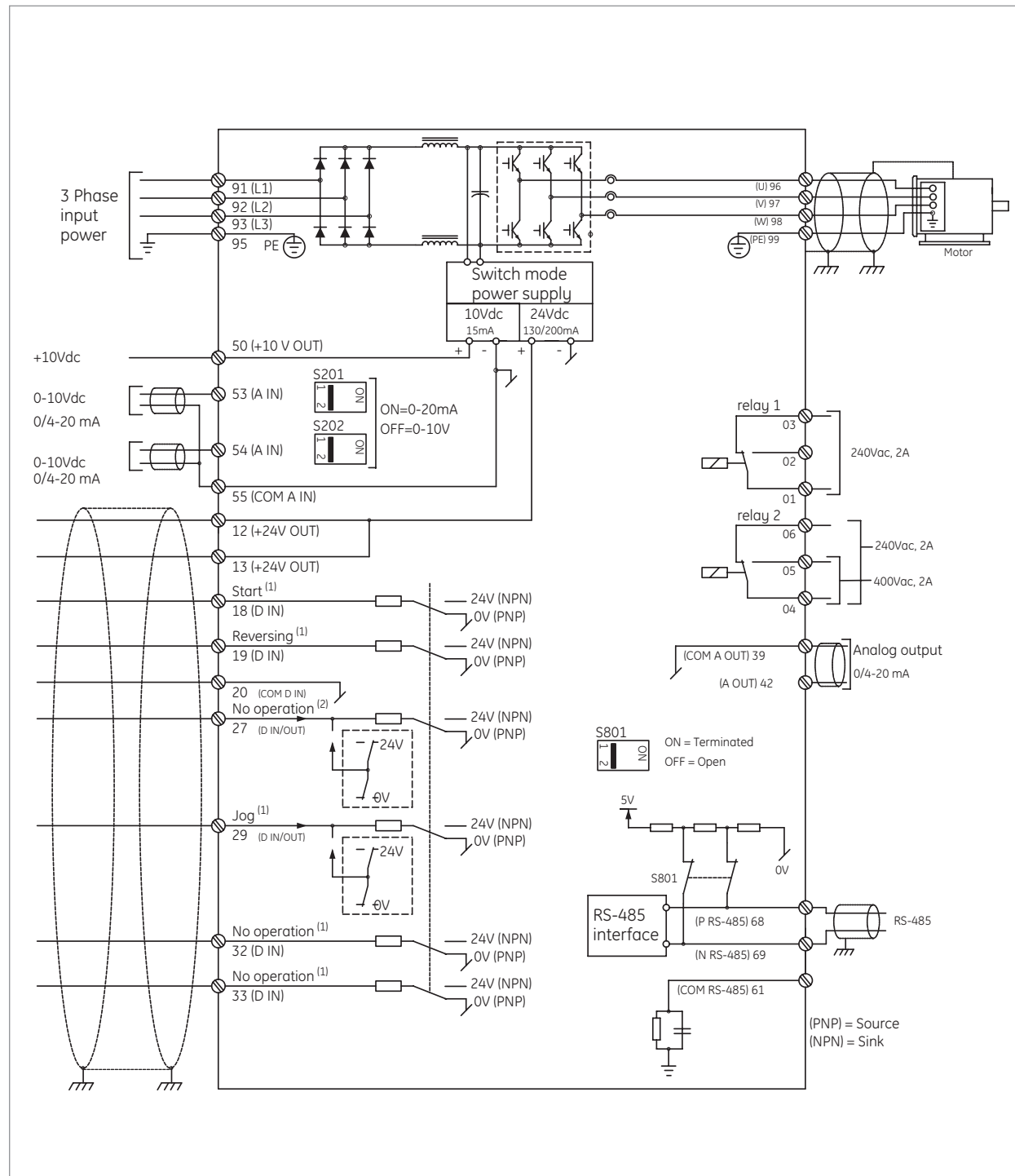

(1) Indicates default setting; see parameter group E-## to re-program.  
 (2) Indicates default setting for version 1.10 drives or higher. Prior versions are set to coast inverse, indicating that terminal #27 must be Logic "high" to enable the drive to run. See parameter E-03 terminal 27 digital input to re-program.

Fan and Pump Drives

Intro

A

B

C

D

E

F

G

H

I

J/X



New

Specifications

Environmental conditions

Enclosures	IP20 chassis, IP00 chassis, IP21/NEMA 1, IP55/NEMA 12, IP54/NEMA 12
Plenum ratings	Drives and options are UL rated for installation inside air handling ducts and plenums
Installation location	Do not install in locations where product could be exposed to dust, corrosive gas, inflammable gas, oil mist, vapor, water drops or direct sunlight. There must be no salt in the atmosphere. Condensation must not be caused by sudden changes in temperature. For use at altitudes of 3280 ft. (1000 m) or less without derating.
Storage temperature	-25° to 65° C
Ambient temperature	-10° to +50° C (24 hour average max of 45° C)
Ambient humidity	5 to 95 % RH (non-condensing)
Vibration	1.0 G
Cooling method	Fan cooled all ratings. Fan control auto, 50 % level, 75 % level, 100 % level adjustable

Standards

Approvals	CE, UL, cUL, and C-Tick Suitable for use on a circuit capable of delivering not more than 100,000 rms symmetrical amperes for 230V and 400V.
-----------	---

Input power supply

Rated input AC voltage	200-240 Vac, 3-phase, 50-60 Hz, +/- 10% V 380-480 Vac, 3-phase, 50-60 Hz, +/- 10% V
Maximum voltage imbalance	3% of rated supply voltage
True power factor	> 0.9 nominal at rated load
Displacement power factor	> 0.98
Switching on input power supply	Maximum twice/minute up to 7.5kW/10HP, maximum once/minute above 7.5kW/10HP
Environment according to EN60664-1	Overvoltage category III/pollution degree 2
DC link reactors	Built-In DC Link Reactors on all ratings
RFI filters	Built-In RFI Filters to reduce noise generated by the drive. Meets industrial standards.

Output

Rated output voltage	0-100% of supply voltage
Output frequency	0-1000 Hz; 0-800Hz for 400V above 90kW/ 125HP
Switching on output	Unlimited
Accel/decel times	1-3600 seconds
Control method	Sinusoidal PWM control (V/Hz, Avd. vector control)

Control

Starting torque	110% starting torque for 1 minute (variable torque)
Carrier frequency (motor noise)	Selectable - 1, 1.5, 2, 2.5, 3, 3.5, 4, 5, 6, 7, 8, 10, 12, 14, 16 kHz
Torque boost	0 - 300% setting to compensate voltage in relation to the load at low speed
Acceleration/deceleration time	0.01-3600 seconds (4 acceleration and deceleration times are selectable via digital inputs. Acceleration and deceleration patterns can be selected from linear or S-curve)
Data protection	Password protection for quick menu or main menu, 0-9999.
Pattern operation	Settings via built-in logic controller sequencer
Jump frequency control	4 jump (or skip) frequencies via parameter set to avoid mechanical vibration
Slip compensation	Maintains motor at constant speed with load fluctuations
Torque limit control	Output torque can be controlled within a range of 0.0 to 110% (0.1 and steps)
8 preset speeds	8 programmable preset speeds selectable by 3 digital inputs
Preset speeds	8 presets via digital inputs
Built-in communications	Drive RS-485, Modbus RTU, Metasys N2, or Apogee FLN P1
Trim reference setting	Available for speed reference offset via potentiometer, voltage input, or current input
DC injection braking	Starting frequency: 0.0-1000 Hz, 0-800Hz for 400V above 90kW/125HP Braking time: 0.0-60.0 seconds Braking level: 0-100% of rated current
Jogging operation	Operation via on key or digital input (fwd or rev)
Auto-restart after power failure	Restarts the drive without stopping after instantaneous power failure
Energy savings	Controls output voltage to minimize motor loss during constant speed operation
Start mode function	This functionality smoothly catches a spinning motor
Fire override mode	Overrides drive's protective features and keeps motor running
Pump cascade controller	Distributes running hours evenly over up to 4 pumps
Sleep mode	Drive detects low or no flow conditions and adjusts output
Dry pump detection	Detects pump operation and can set off alarm, shuts off, or other programmed actions
Belt monitoring	Drive can detect relationship between current and speed to recognize a broken belt
Real time clock	With programmable timed actions

Logic controller (LC) sequencer

Logic controller events	Up to 38 programmable events
Comparators	Array of 6 comparators
Timers	Array of 8 timers, adjustable from 0.0 to 3600 sec
Logic rules	Array of 6 boolean logic rules
Logic controller states	Array of 20 logic controller action states

Process controller (PID)

Process PID controller	4 auto tune PID controllers built-in
Process CL feedback select	Up to 2 references. Selectable - no function, motor feedback, separate encoder, encoder option module, or resolver option module
Process PID control	Normal or inverse
Process PID anti windup	Disabled or enabled
Process PID start speed	0.0-200 Hz
Process PID proportional gain	0.00-10.00
Process PID integral time	0.1 - 10000.0 ms
Process PID differential time	0.0 - 10 s
Process PID differential gain	1.0-50.00
Process PID feed forward factor	0-500%
On reference bandwidth	0-200%

## Specifications

### Operation

<b>Operation method</b>	Keypad operation: hand, off, auto digital input: programmable for start/stop, forward/reverse, jog timer operation: stop after predetermined time frame Communications: RS-485 Modbus RTU, Metasys N2, and Apogee FLN P1 USB port for programming drive with optional PC software
<b>Frequency reference signal</b>	Left or right arrow buttons on keypad in manual mode Speed potentiometer: 0 to +10Vdc, 10 to 0Vdc 0-10Vdc analog input 0/4-20 ma analog input
<b>References</b>	Up to 3 Input references can be selected from analogue input #1 or #2, frequency input #1 or #2, network, or potentiometer
<b>Input signals</b>	No operation Reset after drive trip or alarm Drive at stop with no holding current Quick stop according to quick stop decel time 1 Stop on input going low Start Maintained start after signal applied for minimum of 2ms Reversing Start reverse Enable start forward only Enable start reverse only Jog Multi-step frequency selection (1 to 8 Steps) Hold drive frequency Hold reference Speed up; activated by hold drive frequency or hold reference Slow down; activated by hold drive frequency or hold reference Drive parameter setup select 1-4 Precise start or stop; activated when drive parameter precise start or stop function is selected catch up or slow down; activated by signal to add to or subtract from input reference to control speed Pulse input selectable from 100 - 110kHz Accel / decel time select. Set input to Accel / decel times 1 to 4 Digital potentiometer input increase or decrease Mechanical brake feedback

### Keypad

<b>Keypad features</b>	LCD display with 6 alpha-numeric lines. Multi-language support Hot pluggable, remote mount option, and copy-cat Feature, IP65 rating when remote mounted on enclosure LED's - green - drive is on, yellow - indicates a warning, red - indicates an alarm, amber - indicates active menu keys and H-O-A keys
<b>Keypad keys</b>	Status - shows status of drive Quick menu - enters quick start, parameter data check, or trending modes Main menu - used for programming all drive parameters Alarm log - used to display alarm list Back - reverts to previous step or layer in parameter structure Cancel - used to cancel last change or command Info - displays information about a command, parameter, or function in any display. Hand/off/auto - used to control drive locally or put drive in remote mode Reset - used to reset warnings or alarms
<b>Password</b>	2 level password protection
<b>Alternate motor parameters</b>	Up to 4 separate complete parameter set-ups are available
<b>Graphical trending</b>	Trend speed, power, frequency

### RS485 Modbus RTU serial communications

<b>Physical level</b>	EIA/RS485
<b>Transmission distance</b>	1640 ft (500m)
<b>Node address</b>	32
<b>Transmission speed</b>	2400, 4800, 9600, 19200, 38400, or 115200 (bits/s)
<b>Transmission mode</b>	Half Duplex
<b>Transmission protocol</b>	Modbus RTU
<b>Character code</b>	Binary
<b>Character length</b>	8 bits
<b>Error check</b>	CRC

### Mounting clearance

All AF-600 FP drives can be mounted side-by-side without spacing. For all drives rated 90kW /125HP or below allow 3.4 inches (100mm) free space above and below.  
For all drives rated 110kW/150HP and above allow 8.9 inches (225mm) free space above and below.

### Fan and Pump Drives

Intro

A

B

C

D

E

F

G

H

I

J/X



New



Efficiency, Watt loss, unit size, dimensions and weights

230 Vac, 3-phase, 50/60Hz

Nominal motor ratings			Efficiency			Watt loss (W)	Unit size	Drive type	Height (mm)	Width (mm)	Depth (mm)	Weight (kg)
Power kW	Power HP	Current A	at 5 kHz (%)	at 4 kHz (%)	at 3 kHz (%)							
0.75	1	6.6	96			63	12	IP20 Chassis	375	90	220	5
1.5	2	7.5	96			82	12	IP20 Chassis	375	90	220	5
2.2	3	10.6	96			116	12	IP20 Chassis	375	90	220	5
4	5	16.7	96			185	13	IP20 Chassis	375	90	220	5
5.5	7.5	24.2		96		269	23	IP20 Chassis	375	130	220	7
7.5	10	30.8		96		310	23	IP20 Chassis	375	130	220	7
11	15	46.2		96		447	23	IP20 Chassis	420	165	262	12
15	20	59.4		96		602	24	IP20 Chassis	420	165	262	12
18.5	25	74.8		96		737	24	IP20 Chassis	595	230	242	24
22	30	88			97	845	33	IP20 Chassis	595	230	242	24
30	40	115			97	1140	33	IP20 Chassis	595	230	242	24
37	50	143			97	1353	34	IP20 Chassis	630	308	334	35
45	60	170			97	1636	34	IP20 Chassis	630	308	334	35

400 Vac, 3-phase, 50/60Hz

Nominal motor ratings			Efficiency				Watt loss (W)	Unit size	Drive type	Height (mm)	Width (mm)	Depth (mm)	Weight (kg)
Power kW	Power HP	Current A	at 5 kHz (%)	at 4 kHz (%)	at 3 kHz (%)	at 2 kHz (%)							
0.75	1	2.4	96				58	12	IP20 Chassis	375	90	220	5
1.5	2	4.1	97				62	12	IP20 Chassis	375	90	220	5
2.2	3	5.6	97				88	12	IP20 Chassis	375	90	220	5
4	5	10	97				124	12	IP20 Chassis	375	90	220	5
5.5	7.5	13	97				187	13	IP20 Chassis	375	90	220	5
7.5	10	16	97				255	13	IP20 Chassis	375	130	220	7
11	15	24		98			278	23	IP20 Chassis	375	130	220	7
15	20	32		98			392	23	IP20 Chassis	420	165	262	12
18.5	25	37.5		98			465	23	IP20 Chassis	420	165	262	12
22	30	44		98			525	24	IP20 Chassis	595	230	242	24
30	40	61		98			698	24	IP20 Chassis	595	230	242	24
37	50	73		98			739	24	IP20 Chassis	595	230	242	24
45	60	90			98		843	33	IP20 Chassis	630	308	334	35
55	75	106			98		1083	33	IP20 Chassis	630	308	334	35
75	100	147			98		1384	34	IP20 Chassis	800	370	334	50
90	125	177			99		1474	34	IP20 Chassis	800	370	334	50
110	150	212			98		3234	43	IP00 Chassis	1046	407.9	374.9	91
132	200	260			98		3782	43	IP00 Chassis	1046	407.9	374.9	91
160	250	315			98		4213	44	IP00 Chassis	1327	407.9	374.9	138
200	300	395			98		5119	44	IP00 Chassis	1327	407.9	374.9	138
250	350	480			98		5893	44	IP00 Chassis	1327	407.9	374.9	138
315	450	600				98	7630	52	IP00 Chassis	1547	585	497.8	313
355	500	658				98	7701	52	IP00 Chassis	1547	585	497.8	313
400	550	745				98	8879	52	IP00 Chassis	1547	585	497.8	313
450	600	800				98	9428	52	IP00 Chassis	1547	585	497.8	313
500	650	80				98	10647	61	IP21/NEMA 1	2282	1400	606	1004
560	750	990				98	12338	61	IP21/NEMA 1	2282	1400	606	1004
630	900	1120				98	13201	61	IP21/NEMA 1	2282	1400	606	1004
710	1000	1260				98	15436	61	IP21/NEMA 1	2282	1400	606	1004
800	1200	1460				98	18084	62	IP21/NEMA 1	2282	1800	606	1262
1000	1350	1720				98	20358	62	IP21/NEMA 1	2282	1800	606	1262

AF-6 drives

Intro

A

B

C

D

E

F

G

H

I

J/X



Dimensional drawings

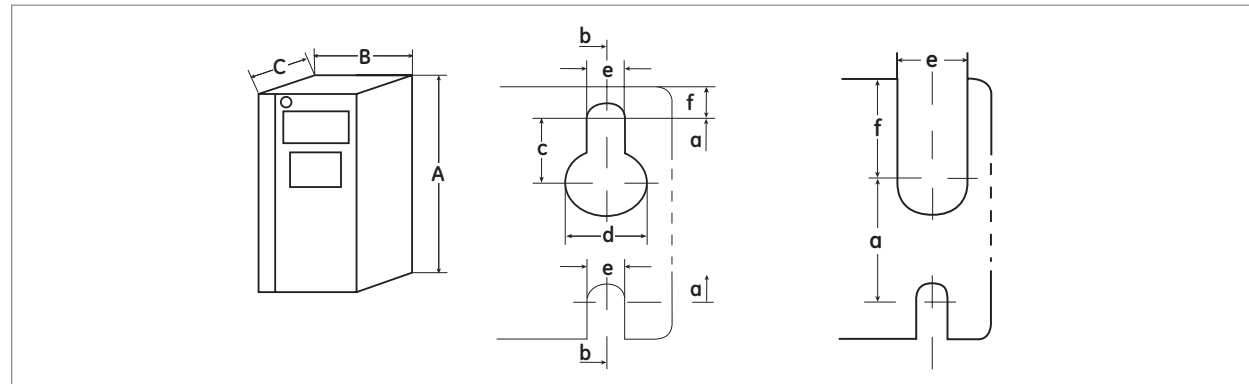

Dimensions, 1X unit sizes (mm)

Unit size		Dimensions	12	13	15
<b>Enclosure type</b>			IP20 Open chassis	IP20 Open chassis	IP55 NEMA 12
<b>Voltage</b>	230V		0.75 to 2.2kW 1 to 3HP	3.7kW 5HP	0.75 to 3.7kW 1 to 5HP
	400V		0.75 to 2.2kW 1 to 5HP	5.5 to 7.5kW 7.5 to 10HP	0.75 to 7.5kW 1 to 10HP
<b>Height</b>	Height of backplate	A	268	268	420
	Height with de-coupling plate	A	375	375	
	Distance between mounting holes	a	257	257	402
<b>Width</b>	Width of backplate	B	90	130	242
	Distance between mounting holes	b	70	110	215
<b>Depth</b>	Depth without I/O and/or network option	C	205	205	195
	Depth with I/O and/or network option	C	220	220	195
<b>Screw holes</b>		c	8.0	8.0	8.3
		d	11.0	11.0	12.0
		e	5.5	5.5	6.5
		f	9.0	9.0	9.0
<b>Weight (kg)</b>			4.9	6.6	13.5 / 14.2

Dimensions, 2X unit sizes (mm)

Unit size		Dimensions	21	22	23	24
<b>Enclosure type</b>			IP55 NEMA 12	IP55 NEMA 12	IP20 Open chassis	IP20 Open chassis
<b>Voltage</b>	230V		5.5 to 11kW 7.5 to 15HP	15kW 20HP	5.5 to 11kW 7.5 to 15HP	15 to 18.5kW 20 to 25HP
	400V		11 to 15kW 15 to 25HP	22 to 30kW 30 to 40HP	11 to 18.5kW 15 to 25HP	22 to 37kW 30 to 50HP
<b>Height</b>	Height of backplate	A	480	650	399	521
	Height with de-coupling plate	A	-	-	420	595
	Distance between mounting holes	a	455	625	380	495
<b>Width</b>	Width of backplate	B	242	242	165	230
	Distance between mounting holes	b	210	210	140	200
<b>Depth</b>	Depth without I/O and/or network option	C	260	260	249	242
	Depth with I/O and/or network option	C	260	260	262	242
<b>Screw holes</b>		c	12.0	12.0	8.0	-
		d	19.0	19.0	12.0	-
		e	9.0	9.0	6.8	8.5
		f	9.0	9.0	7.9	15.0
<b>Weight (kg)</b>			23.0	27.0	12.0	23.5

Fan and Pump Drives

Intro

A

B

C

D

E

F

G

H

I

J/X



New

Dimensional drawings

Dimensions, 3X unit sizes (mm)

Unit size		Dimensions	31	32	33	34
<b>Enclosure type</b>			IP55	IP55	IP20	IP20
			NEMA 12	NEMA 12	Open chassis	Open chassis
<b>Voltage</b>	230V		18.5 to 30kW 25 to 40HP	37 to 45kW 50 to 60HP	22 to 30kW 30 to 40HP	37 to 45kW 50 to 60HP
	400V		37 to 55kW 50 to 75HP	75 to 90kW 100 to 125HP	45 to 55kW 60 to 75HP	75 to 90kW 100 to 125HP
<b>Height</b>	Height of backplate	<b>A</b>	680	770	550	660
	Height with de-coupling plate	<b>A</b>	-	-	630	800
	Distance between mounting holes	<b>a</b>	648	739	521	631
<b>Width</b>	Width of backplate	<b>B</b>	308	370	308	370
	Distance between mounting holes	<b>b</b>	272	334	270	330
<b>Depth</b>	Depth without I/O and/or network option	<b>C</b>	310	335	333	333
	Depth with I/O and/or network option	<b>C</b>	310	335	333	333
<b>Screw holes</b>		<b>c</b>	12.5	12.5	-	-
		<b>d</b>	19.0	19.0	-	-
		<b>e</b>	9.0	9.0	8.5	8.5
		<b>f</b>	9.8	9.8	17.0	17.0
<b>Weight (kg)</b>			45	65	35	50

Dimensions IP20 open chassis drives with field installed IP21/NEMA 1 kits<sup>(1)</sup> (mm)

Unit size		12	13	23	24	33	34
<b>Enclosure type</b>		IP20 open chassis with IP21/NEMA 1 Kit					
<b>Voltage</b>	230V	0.75 to 2.2kW 1 to 3HP	3.7kW 5HP	5.5 to 11kW 7.5 to 15HP	15 to 18.5kW 20 to 25HP	22 to 30kW 30 to 40HP	37 to 45kW 50 to 60HP
	400V	0.75 to 2.2kW 1 to 5HP	5.5 to 7.5kW 7.5 to 10HP	11 to 18.5kW 15 to 25HP	22 to 37kW 30 to 50HP	45 to 55kW 60 to 75HP	75 to 90kW 100 to 125HP
<b>Height</b>	Height with kit	375	375	475	671	754	950
<b>Width</b>	Width of backplate	94	130	165	231	397	371
	Distance between mounting holes	70	110	140	201	269	330
<b>Depth</b>	Depth without I/O and/or network option	205	205	249	242	338	338
	Depth with I/O and/or network option	220	220	262	242	338	338

(1) Please consult IP21/NEMA 1 kit instructions for further mounting details and dimensions.

Note: Please allow 5cm / 2" between drives with field installed IP21/NEMA 1 Kits. Also, please consult the relevant AF-6 Series drives operating Instructions for recommended clearance above and below each drive rating.

AF-6 drives

Intro

A

B

C

D

E

F

G

H

I

J/X



Dimensional drawings in mm (inches)

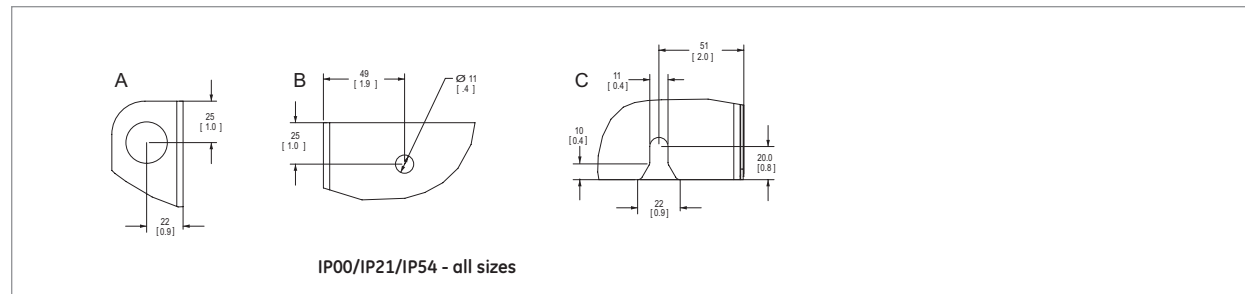
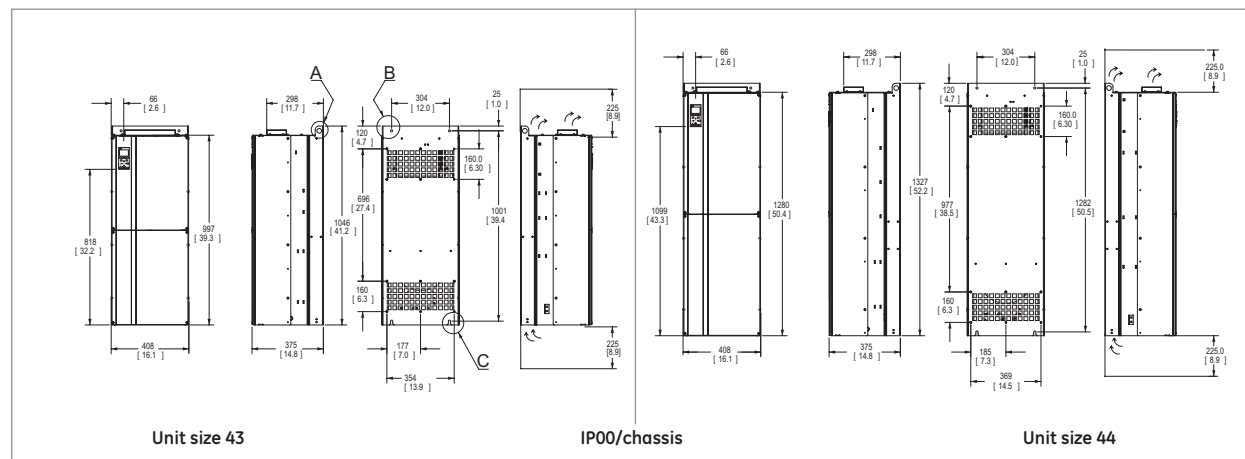
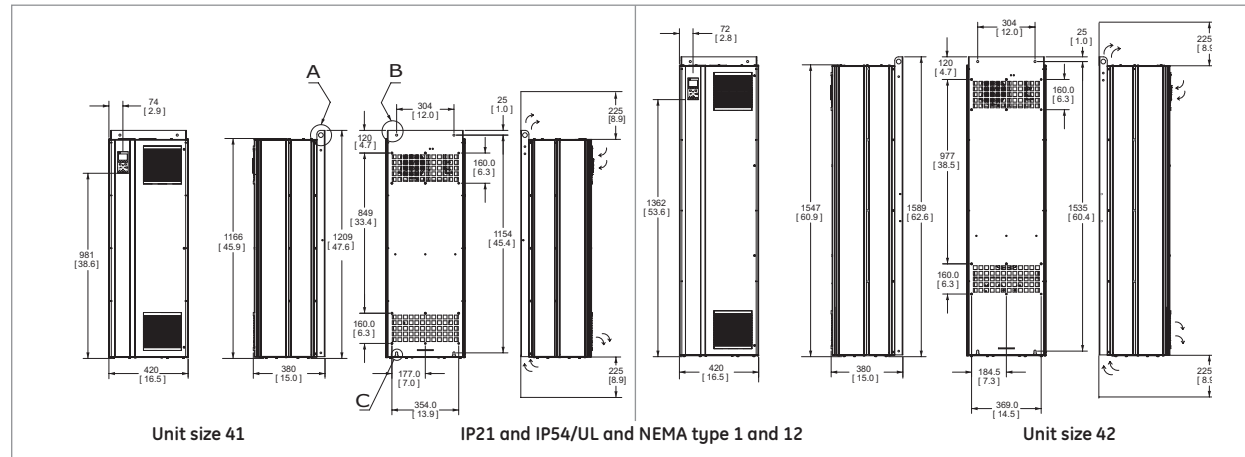

Unit size	41	42	43	44
Enclosure type	IP21/IP54 NEMA 1/NEMA 12	IP21/IP54 NEMA 1/NEMA 12	IP00 Open chassis	IP00 Open chassis
Voltage	400V 110 to 132kW 150 to 200HP	160 to 250kW 250 to 350HP	110 to 132kW 150 to 200HP	160 to 250kW 250 to 350HP
Shipping dimensions	Height: 650 Width: 1730 Depth: 570	Height: 650 Width: 1730 Depth: 570	Height: 650 Width: 1220 Depth: 570	Height: 650 Width: 1490 Depth: 570
Drive dimensions	Height: 1209 Width: 420 Depth: 380	Height: 1589 Width: 420 Depth: 380	Height: 1046 Width: 408 Depth: 375	Height: 1327 Width: 408 Depth: 375
Weight (kg)	104	106	91	138

Fan and Pump Drives

Intro

A

B

C

D

E

F

G

H

I

J/X



New

Dimensional drawings in mm (inches)

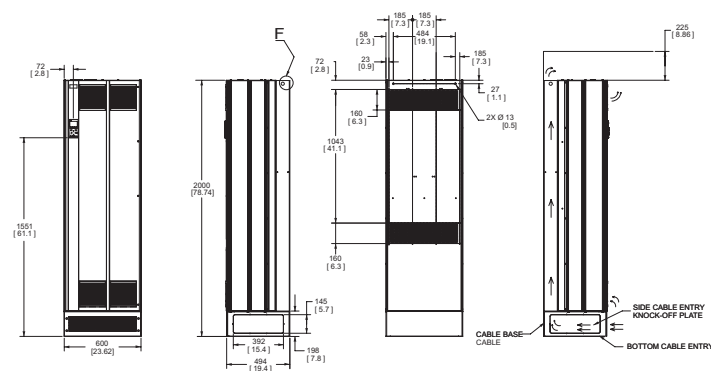

Unit size 51, IP21 and IP54/UL and NEMA type 1 and 12

Unit size 51

Enclosure type	IP21/IP55 NEMA 1/NEMA 12
Voltage 400V	315 to 450kW 450 to 600HP
<b>Shipping dimensions</b>	
Height	841
Width	2197
Depth	734
<b>Drive dimensions</b>	
Height	2000
Width	600
Depth	494
Weight (kg)	313

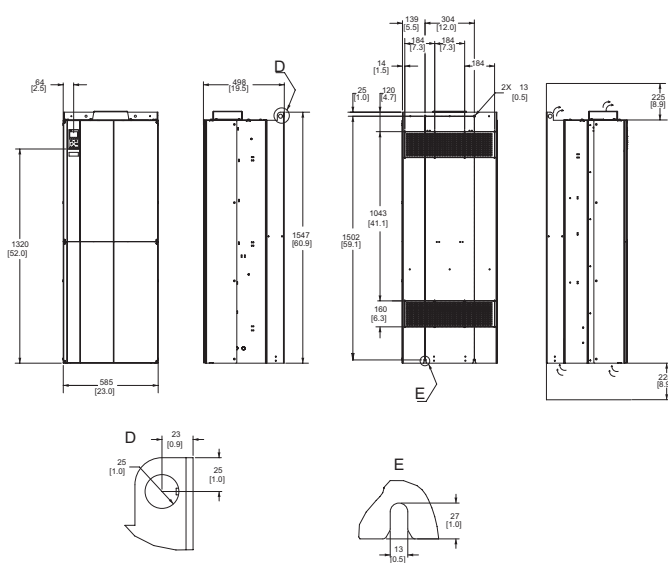

Unit size 52, IP00/chassis

Unit size 52

Enclosure type	IP00 Open chassis
Voltage 400V	315 to 450kW 450 to 600HP
<b>Shipping dimensions</b>	
Height	831
Width	1704
Depth	734
<b>Drive dimensions</b>	
Height	1547
Width	585
Depth	498
Weight (kg)	313

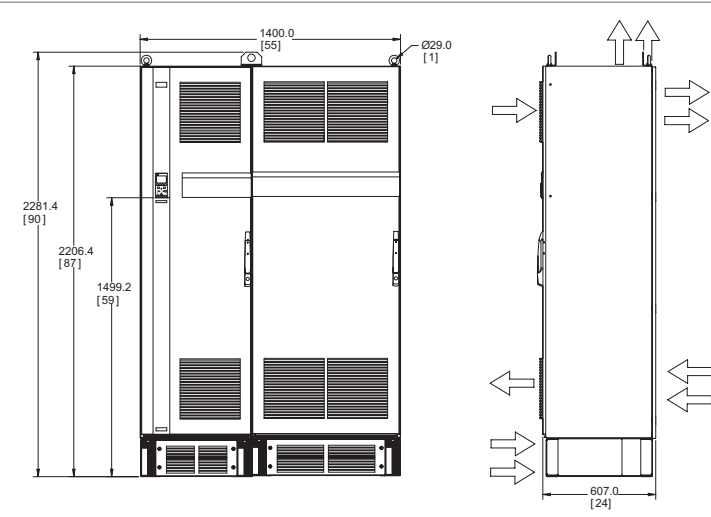

Unit size 61

Unit size 61

Enclosure type	IP21/IP55 NEMA 1/NEMA 12
Voltage 400V	500 to 710kW 650 to 1000HP
<b>Shipping dimensions</b>	
Height	2324
Width	1570
Depth	927
<b>Drive dimensions</b>	
Height	2282
Width	1400
Depth	607
Weight (kg)	1004

Dimensional drawings in mm (inches)

**Unit size 62**

Unit size 62	
<b>Enclosure type</b>	IP21/IP55 NEMA 1/NEMA 12
<b>Voltage 400V</b>	800 to 1000kW 1200 to 1350HP
<b>Shipping dimensions</b>	
Height	2324
Width	1961
Depth	419
<b>Drive dimensions</b>	
Height	2282
Width	1800
Depth	606
<b>Weight (kg)</b>	1262

**Unit size 63**

Unit size 63	
<b>Enclosure type</b>	IP21/IP55 NEMA 1/NEMA 12
<b>Voltage 400V</b>	500 to 710kW 650 to 1000HP
<b>Shipping Dimensions</b>	
Height	2324
Width	2159
Depth	927
<b>Drive Dimensions</b>	
Height	2282
Width	2000
Depth	606
<b>Weight (kg)</b>	1300

**Unit size 64**

Unit size 64	
<b>Enclosure type</b>	IP21/IP55 NEMA 1/NEMA 12
<b>Voltage 400V</b>	800 to 1000kW 1200 to 1350HP
<b>Shipping dimensions</b>	
Height	2324
Width	2543
Depth	927
<b>Drive dimensions</b>	
Height	2282
Width	2400
Depth	606
<b>Weight (kg)</b>	1541

Fan and Pump Drives

Intro

A

B

C

D

E

F

G

H

I

J/X



New

### Dynamic Braking Resistors

dynamic braking allows for faster deceleration rates then could be achieved via a coast to stop. Dynamic braking consists of the internal drive brake chopper and separate add-on dynamic braking resistors. Important application notes:

- The AF-60 LP Micro Drive dynamic braking can be used for stopping a load with an inertia equal to or less than the applied motor's rotor inertia.
- High inertia or overhauling loads may cause extended deceleration times which could cause overheating and tripping of the drive.
- The dynamic braking is not a holding brake. It does not prevent a motor at rest from rotating.

Note: refer to the drives' Operating Instruction for installation and connection details.

#### Dynamic braking resistors- AF-60 LP drives 230 Vac

Nominal applied motor kW	Nominal applied motor HP	Max. braking torque (%)	Brake chopper	Recommended dynamic braking resistor				Total Ohms	Total kW	
				10% duty cycle		40% duty cycle			10% duty cycle	40% duty cycle
				Cat. No.	Ref. No.	Cat. No.	Ref. No.			
0.18	1/4	-	N/A	-	-	-	-	-	-	
0.37	1/2	-	N/A	-	-	-	-	-	-	
0.75	1	-	N/A	-	-	-	-	-	-	
1.5	2	150	Built-in	TLR74P200	129870	4 x TLR74P200	4 x 129870	74	0.2	0.8
2.2	3	150	Built-in	TLR44P600	129166	TLR43P1000	129177	44	0.6	1
3.7	5	150	Built-in	TLR29P600	129167	TLR22P2500	129879	29	0.6	2.5

#### 400 Vac

Nominal applied motor kW	Nominal applied motor HP	Max. braking torque (%)	Brake chopper	Recommended dynamic braking resistor				Total Ohms	Total kW	
				10% duty cycle		40% duty cycle			10% duty cycle	40% duty cycle
				Cat. No.	Ref. No.	Cat. No.	Ref. No.			
0.37	1/2	-	N/A	-	-	-	-	-	-	
0.75	1	-	N/A	-	-	-	-	-	-	
1.5	2	150	Built-in	TLR295P200	129876	4 x TLR295P200	4 x 129876	295	0.2	0.8
2.2	3	150	Built-in	TLR216P200	129868	4 x TLR216P200	4 x 129868	216	0.2	0.8
4	5	150	Built-in	TLR118P600	129174	4 x TLR118P600	4 x 129174	118	0.6	2.4
5.5	8	150	Built-in	TLR86P600	129175	4 x TLR86P600	4 x 129175	86	0.6	2.4
7.5	10	150	Built-in	TLR59P1000	129176	4 x TLR59P1000	4 x 129176	59	1	4
11	15	150	Built-in	TLR43P1000	129177			43	1	-
15	20	150	Built-in	TLR35P1500	129877			35	1.5	-
18.5	25	150	Built-in	TLR29P1800	129878	On request		29	1.8	-
22	30	150	Built-in	TLR22P2500	129879			22	2.5	-

AF-6 drives

Intro

A

B

C

D

E

F

G

H

I

J/X



New

Dynamic braking resistors - AF-650 GP drives

230 Vac

Nominal applied motor kW	Nominal applied motor HP	Max. braking torque (%)	Repetitive braking torque duty - 10%					Repetitive braking torque duty - 40%				
			(kW)	Ohms	Cont. max breaking time(s)	Cat. No.	Ref. No.	(kW)	Ohms	Cont. max breaking time(s)	Cat. No.	Ref. No.
0.25	1/3	160	0.2	405	12	TLR405P200	129867	0.43	425	120	TLR405P200	129867
0.37	1/2	160	0.2	295	12	TLR295P200	129876	0.80	310	120	4 x TLR295P200	4 x 129876
0.75	1	160	0.6	118	12	TLR118P600	129174	0.26	145	120	TLR118P600	129174
1.5	2	160	1	59	12	TLR59P1000	129176	0.80	65	120	TLR59P1000	129176
2.2	3	160	1	43	12	TLR43P1000	129177	1.00	50	120	TLR43P1000	129177
3.7	5	160	1.8	29	12	TLR29P1800	129878	3.00	25	120	TLR22P2500	129879
5.5	7.5	158	2.5	22	12	TLR22P2500	129879	-	-	-	-	-
7.5	10	153	3	17.6	12	2 x TLR8,8P1500	2 x 129171	-	-	-	-	-
11	15	154	5	10	12	2 x TLR5P2500	2 x 129871	-	-	-	-	-
15	20	150	6	8	12	2 x TLR4P3000	2 x 129872	-	-	-	-	-
18.5	25	150	6	8	12	2 x TLR4P3000	2 x 129872	-	-	-	-	-
22	30	150	6	4.7	30	-	-	-	-	-	-	-
30	40	150	8	3.3	30	On request	-	-	-	-	-	-
37	50	150	10	2.7	30	-	-	-	-	-	-	-

400 Vac

Nominal applied motor kW	Nominal applied motor HP	Max. braking torque (%)	Repetitive braking torque duty - 10%					Repetitive braking torque duty - 40%				
			(kW)	Ohms	Cont. max breaking time(s)	Cat. No.	Ref. No.	(kW)	Ohms	Cont. max breaking time(s)	Cat. No.	Ref. No.
0.37	0.5	160	0.2	750	12	TLR750P200	116301	0.2	620	120	TLR750P200	116301
0.75	1	160	0.2	750	12	TLR750P200	116301	0.2	620	120	TLR750P200	116301
1.5	2	160	0.2	295	12	TLR295P200	129876	0.4	310	120	2 x TLR750P200	2 x 116301
2.2	3	160	0.2	216	12	TLR216P200	129868	0.4	210	120	2 x TLR432P200	2 x 129875
4	5	160	0.6	118	12	TLR118P600	129174	2	110	120	2 x TLR59P1000	2 x 129176
5.5	7.5	160	0.6	86	12	TLR86P600	129175	3	80	120	2 x TLR35P1500	2 x 129877
7.5	10	160	1	59	12	TLR59P1000	129176	6	65	120	2 x TLR35P3000	2 x 129888
11	15	160	1	43	12	TLR43P1000	129177	5	40	120	2 x TLR22P2500	2 x 129879
15	20	160	1.5	35	12	TLR35P1500	129877	7.4	30	120	2 x TLR15P3700	2 x 129881
18.5	25	160	1.8	29	12	TLR29P1800	129878	10	25	120	4 x TLR22P2500	4 x 129879
22	30	160	2.5	22	12	TLR22P2500	129879	10	20	120	4 x TLR22P2500	4 x 129879
30	40	150	3.7	15	12	TLR15P3700	129881	14.8	15	120	4 x TLR15P3700	4 x 129881
37	50	150	4.7	12.5	12	-	-	-	-	-	-	-
45	60	150	6.4	9.2	12	-	-	-	-	-	-	-
55	75	150	7.7	4.3	12	-	-	-	-	-	-	-
75	100	150	13.6	4.3	12	-	-	-	-	-	-	-
90	125	150	17	3.4	30	-	-	-	-	-	-	-
110	150	150	17	3.4	30	-	-	-	-	-	-	-
132	200	150	22.5	10.4	30	-	-	-	-	-	-	-
160	250	150	27.2	8.6	30	-	-	-	-	-	-	-
200	300	150	17	3.3	30	-	-	-	-	-	-	-
250	350	150	22.4	10.4	30	-	-	-	-	-	-	-
355	450	150	27.2	8.6	30	-	-	-	-	-	-	-
400	550	150	14.4	1.3	30	-	-	-	-	-	-	-
450	600	150	14.4	1.3	30	-	-	-	-	-	-	-
500	650	150	14.4	1.3	30	-	-	-	-	-	-	-
560	750	150	14.4	1.3	30	-	-	-	-	-	-	-
630	900	150	14.4	1.3	30	-	-	-	-	-	-	-
710	1000	150	14.4	1.3	30	-	-	-	-	-	-	-
800	1200	150	14.4	1.3	30	-	-	-	-	-	-	-

690 Vac

Nominal applied motor kW	Nominal applied motor HP	Max. braking torque (%)	Repetitive braking torque duty - 10%					Repetitive braking torque duty - 40%				
			(kW)	Ohms	Cont. max breaking time(s)	Cat. No.	Ref. No.	(kW)	Ohms	Cont. max breaking time(s)	Cat. No.	Ref. No.
90	125	160	126	9.8	60	DB6101TBNC	-	77	9.8	120	DB6401TBNC	-
110	150	160	153	7.3	60	DB6102TBNC	-	93	7.3	120	DB6402TBNC	-
132	200	160	185	4.7	60	DB6103TBNC	-	113	4.7	120	DB6403TBNC	-
160	250	160	224	4.7	60	DB6104TBNC	On request	137	4.7	120	DB6404TBNC	On request
200	300	160	147	3.8	60	DB6105TBNC	-	90	3.8	120	DB6405TBNC	-
250	350	160	173	2.6	60	DB6106TBNC	-	106	2.6	120	DB6406TBNC	-
315	400	160	212	2.6	60	DB6107TBNC	-	130	2.6	120	DB6407TBNC	-

For higher motor power please contact GE

Braking resistors

Intro

A

B

C

D

E

F

G

H

I

J/X



New



Notes

Grid of dotted lines for notes.

AF-6 drives

Intro

A

B

C

D

E

F

G

H

I

J/X

H.70





				Intro
				A
<b>ASTAT S - Small soft starters</b>	<b>POWER DEVICES</b>	Contactors and overload relays		B
I.3 Order codes				C
I.4 Diagrams		Auxiliary relays and contactors		D
I.5 Performance				E
I.6 Dimensions		Motor protection devices		F
				G
I.7 <b>ASTAT XT - Digital soft starters</b>			Applications	H
I.8 Order codes				I
I.10 Unit configuration			Main switches	J/X
I.11 Technical Data				
I.12 Functions	<b>AUXILIARY DEVICES</b>	Control and signalling units		
I.13 Overload protections				
I.14 I/O Wiring		Electronic relays and limit switches		
I.15 I/O terminal board specifications				
I.18 Wiring diagrams	<b>POWER ELECTRONICS</b>	Speed drive units		
I.20 Coordination tables				
I.22 Dimensions and weights				
			Soft starters	





### Small soft starters with integral by-pass

ASTAT S is compact, easy to operate soft starter, designed for use with standard 3-phase squirrel cage motors. It provides an advanced method of reducing current during motor starting and stopping. ASTAT S will start supplying a reduced voltage to the motor, increasing up to the rated voltage, so avoiding, high currents and generating soft starting and stopping. The motor has to be able to start in a reduced voltage.

- Solid soft starter for standard 3ph AC motors up to 30kW at 400V AC
- Voltage ratings up to 600V
- Two phase control with integral by-pass
- Compact, small case
- DIN rail mounting. Optional from 31A
- Start and soft stop features

### Marking



The cUL, is achieved for all range of ASTAT S, except for 58A models, items QA02P058S, QA12P058S, QA22P058S, QA32P058S.

### Technical data

#### Ratings

Voltage ratings	3ph AC systems 220/230V (+10%, -15%) for units QA02P___S 380/415V (+10%, -15%) for units QA12P___S 480/500V (+10%, -15%) for units QA22P___S 575/600V (+10%, -15%) for units QA32P___S
Frequency range	50/60Hz (±5%)
Load	3ph, AC standard motors

#### Control specifications

Ramp up	0,5 - 10 s
Ramp down	0,5 - 10 s
Initial voltage	0 - 80% Un
Starting torque	0 - 64% Tn

#### I/O control

Inputs	one input for Start/Stop
Outputs	one output for «End of Ramp» signal for ratings 31, 44, 58A

#### Ambient conditions

Operating temperature	0 to 40°C. Up to 60°C derating by 1,2% per °C
Storage temperature	-20 to 70°C
Relative humidity	up to 80%, without condensation
Max. altitude	up to 1000m. Above this derate by 5% each 100m
Protection degree	IP20

- Order codes ● page I.3
- Diagrams ● page I.4
- Performances ● page I.5
- Dimensions ● page I.6



Small soft starters with integral by-pass



Input voltage V CA	Current rating (2) A	Maximum current A	Maximum motor power (1)				Cat. No.	Ref. no.	Pack
			220/230V kW / Hp	380/415V kW / Hp	480/500V kW / Hp	575/600V kW / Hp			
220	8	28	1.5 / 2	-	-	-	QA02P008S	120881	1
	17	60	4 / 5.5	-	-	-	QA02P017S	120882	1
	22	77	5.5 / 7.5	-	-	-	QA02P022S	120883	1
	31	110	7.5 / 10	-	-	-	QA02P031S	120884	1
	44	150	11 / 15	-	-	-	QA02P044S	120885	1
	58	200	15 / 20	-	-	-	QA02P058S	120886	1
400	8	28	-	4 / 5.5	-	-	QA12P008S	120892	1
	17	60	-	7.5 / 10	-	-	QA12P017S	120893	1
	22	77	-	11 / 15	-	-	QA12P022S	120894	1
	31	110	-	15 / 20	-	-	QA12P031S	120895	1
	44	150	-	22 / 30	-	-	QA12P044S	120896	1
	58	200	-	30 / 40	-	-	QA12P058S	120897	1
500	8	28	-	-	5.5 / 7.5	-	QA22P008S	120898	1
	17	60	-	-	11 / 15	-	QA22P017S	120899	1
	22	77	-	-	15 / 20	-	QA22P022S	120900	1
	31	110	-	-	22 / 30	-	QA22P031S	120901	1
	44	150	-	-	30 / 40	-	QA22P044S	120902	1
	58	200	-	-	45 / 60	-	QA22P058S	120903	1
600	8	28	-	-	-	7.5 / 10	QA32P008S	120904	1
	17	60	-	-	-	15 / 20	QA32P017S	120905	1
	22	77	-	-	-	22 / 30	QA32P022S	120906	1
	31	110	-	-	-	30 / 40	QA32P031S	120907	1
	44	150	-	-	-	37 / 50	QA32P044S	120908	1
	58	200	-	-	-	55 / 75	QA32P058S	120909	1
<b>Accessory</b> DIN rail mounting kit for types 31A, 44A and 58A							QAOPTDIN	120910	1

(1) Ratings for standard 4-poles AC motors  
 (2) See Operations/hour in table below  
 Cycles/hour includes both soft start and soft stop

Times between rampings Start/Stop

	Starting current	Ramp 1 sec.	Ramp 2 sec.	Ramp 5 sec.	Ramp 10 sec.
QA_2P008S	8	7	15	35	70
	16	16	33	77	155
	24	26	51	125	250
	28 (*)	32	62	155	-
QA_2P017S	17	7	15	35	70
	34	16	33	77	155
	51	26	51	125	250
	60 (*)	32	62	155	-
QA_2P022S	22	7	15	35	70
	44	16	33	77	155
	66	26	51	125	250
	77 (*)	32	62	155	-
QA_2P031S	31	4	8	20	40
	62	8	15	38	76
	93	12	24	62	124
	110 (*)	15	31	80	-
QA_2P044S	44	4	8	20	40
	88	8	15	38	76
	132	12	24	62	124
	155 (*)	15	31	80	-
QA_2P058S	58	4	8	20	40
	116	8	15	38	76
	174	12	24	62	124
	200 (*)	15	31	80	-

(\*) Maximum starting current at all

Small soft starters

Intro

A

B

C

D

E

F

G

H

I

J/X



Diagrams

Control by permanent command (soft start and stop)

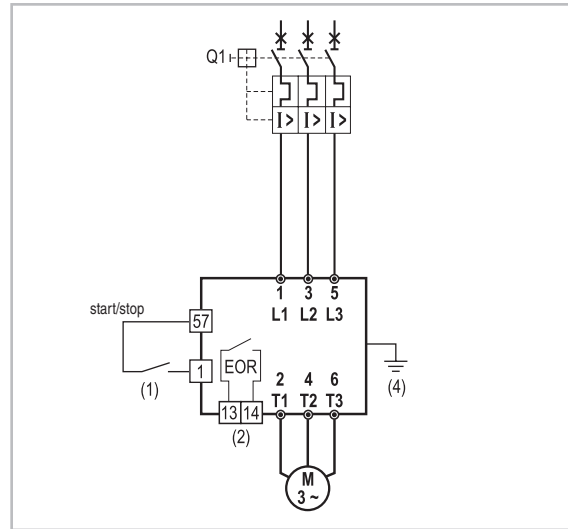

Control by push-buttons, line contactor and thermal overload relay (soft start)

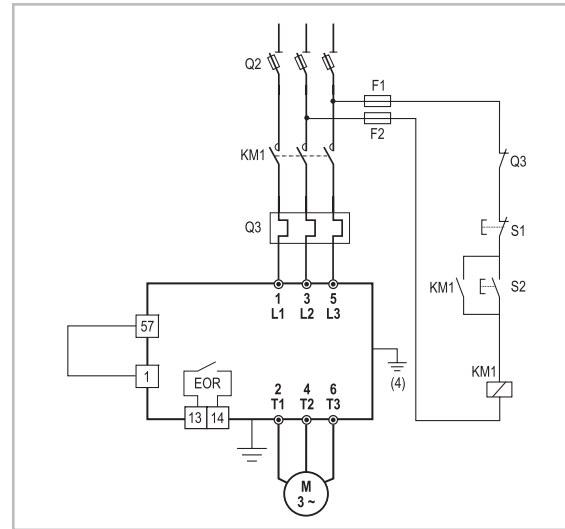

Control by push-buttons and line contactor (soft start)

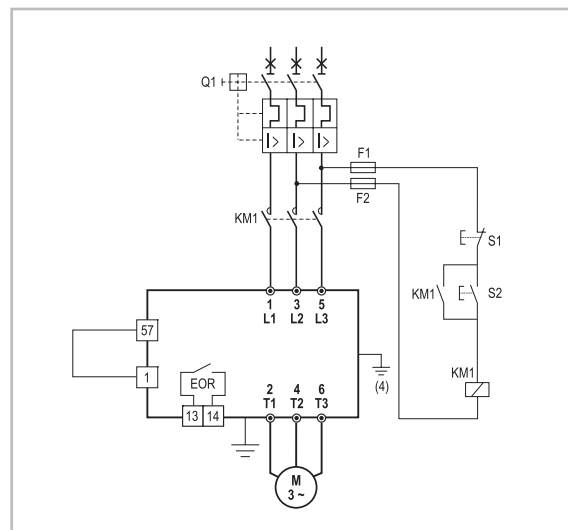

Forward/reverse control by push-buttons (3)

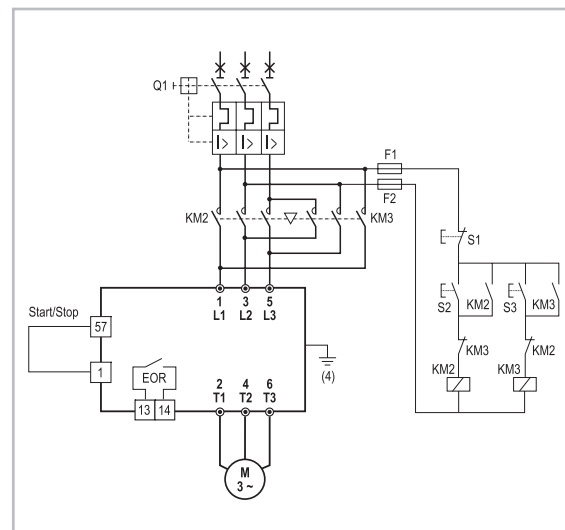

Motor power 380/415V kW	ASTAT S Hp	Q1	Q2 Am fuses	KM1 Contactor	Q3 Thermal overload relay	F1-F2	S1-S2-S3
4	5.5	QA12P008	GPS1B*AK	10	CL25A	RT A 1N	-
7.5	10	QA12P017	GPS1B*AN	25	CL25A	RT A 1S	-
11	15	QA12P022	GPS1B*AP	32	CL25A	RT A 1T	-
15	20	QA12P031	GPS1B*AR	40	CL04A	RT A 1V	-
22	30	QA12P044	GPS2B*AT	63	CL06A	RT A 2F	-
30	40	QA12P058	GPS2B*AU	80	CL07A	RT A 2H	-

Coordination type 1

- (1) Use dry contact only.
- (2) End of Ramp output relay (only types 31A, 44A and 58A).
- (3) Forward/Reverse operation must be done when motor is not rotating.
- (4) Ground terminal only for types 31A, 44A and 58A.

Performances

Direct-on-line start

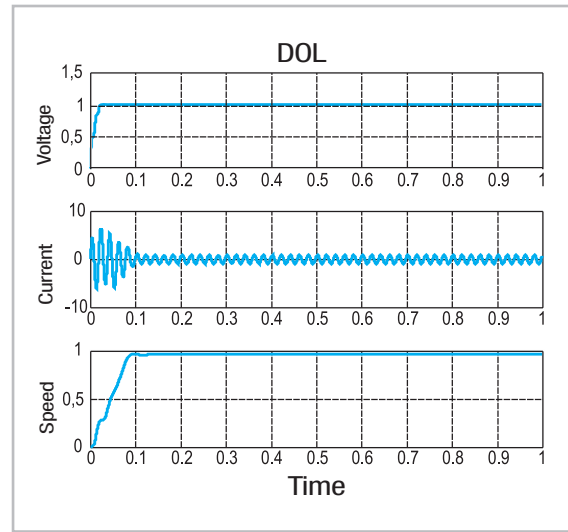

ASTAT S soft start

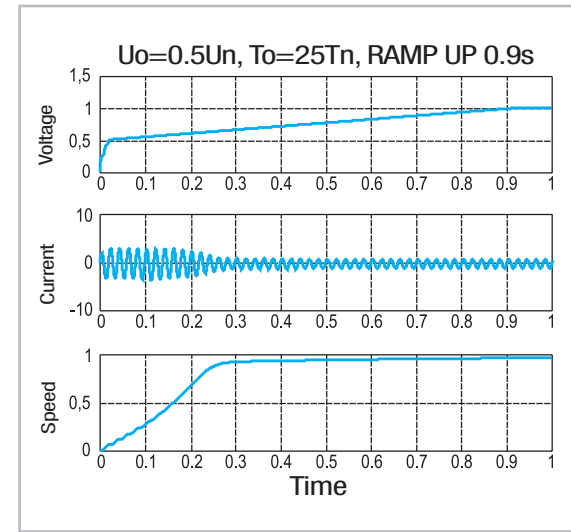

Direct-on-line stop

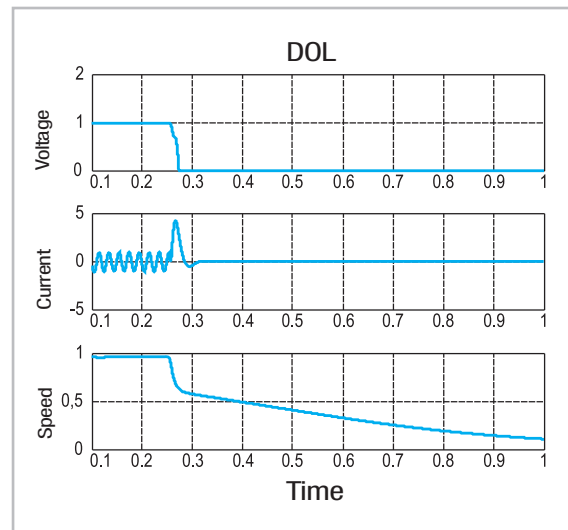

ASTAT S soft stop

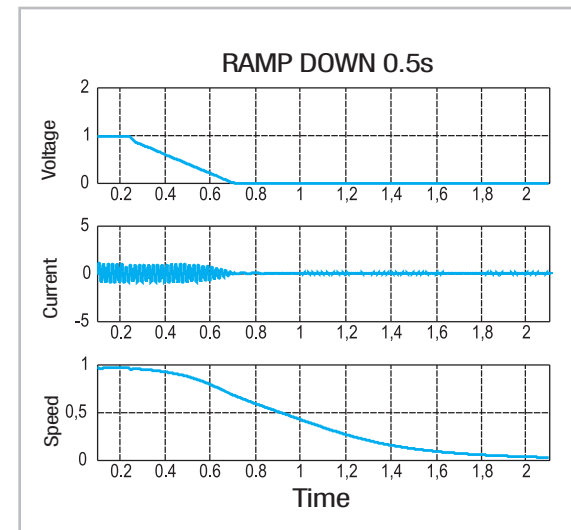

Small soft starters

Intro

A

B

C

D

E

F

G

H

I

J/X



Dimensional drawings

Small soft starter with integral by-pass

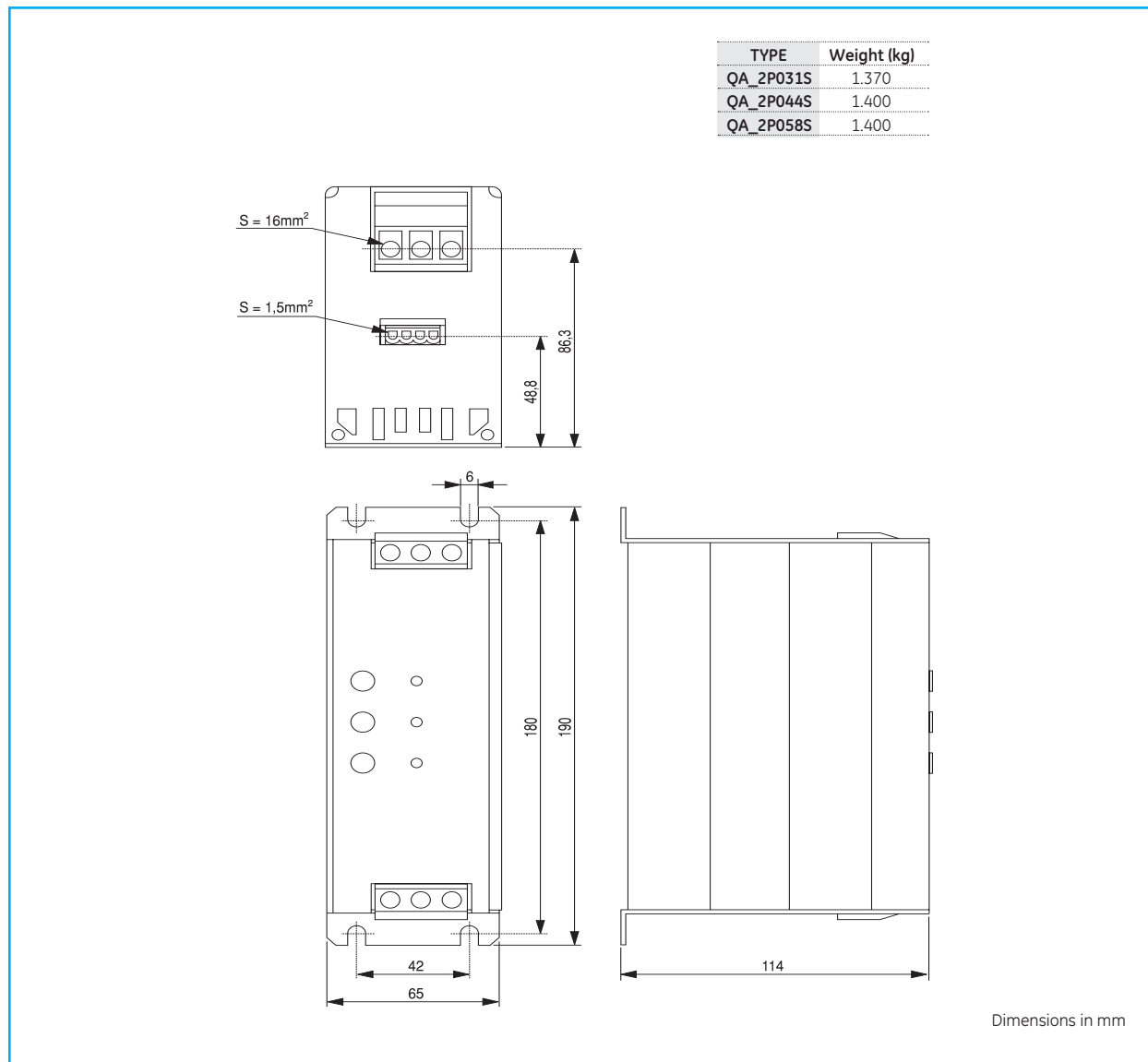
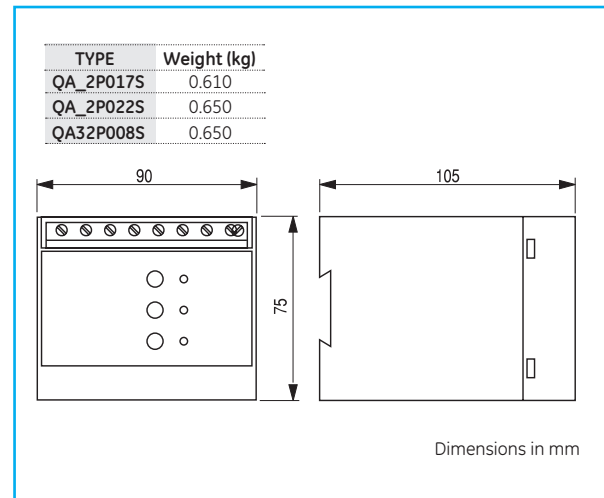
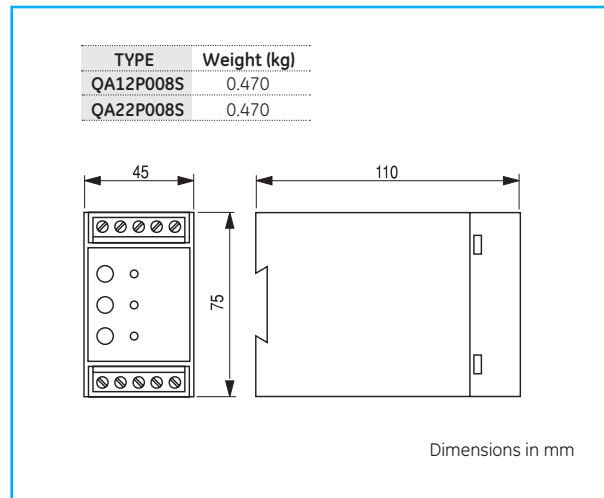

Soft starters

Intro

A

B

C

D

E

F

G

H

I

J/X





**ASTAT XT**

**Digital soft starters for 3ph standard induction motors**

GE's new ASTAT XT solid state soft starter features microprocessor control digital technology. Setup and adjustment is performed through a six-button keypad and parameters or messages are displayed out through a friendly LCD multilanguage interface with two rows, sixteen alphanumeric characters each. The design includes isolated I/O and high level of protection in their circuits to minimize the disturbance effects while working in the hardest industrial environment.

ASTAT XT Soft Starter offers reliable performance and smooth acceleration for a variety of standard AC motors up to 1400A and up to 690V, reducing mechanical shock to the driving system, resulting in extended component and motor life.

ASTAT XT offers many traditional features such a motor overload function, adjustable ramps, current limit, kick start, but also other high end features like inside-delta operation, torque control, pump control and a reliable motor and unit set of protections.

**Key Features**

- Ratings up to 1400Amps and up to 690VAC
- Friendly multilanguage interface with two rows, sixteen characters each
- Built-in with three extra power terminals for external bypass
- In-line or inside-delta operation modes
- Torque control and pump control advanced features
- Motor protection according IEC 10, 20 and NEMA 10, 20, 30, even if ASTAT XT is in by-pass
- Built in communications RS485 port, and ModBus protocol as standard
- ProfibusDP and DeviceNet optional interfaces for communications

**Approvals / Marking**



For units up to 820A. "U" type



**Control panel**



Digital soft starters

Intro

A

B

C

D

E

F

G

H

I

J/X

- Order codes ● pg. I.8
- Technical data ● pg. I.11
- Functions ● pg. I.12
- Overload protections ● pg. I.13
- I/O wiring ● pg. I.14
- Wiring diagrams ● pg. I.16
- Coordination types ● pg. I.20
- Dimensions ● pg. I.22

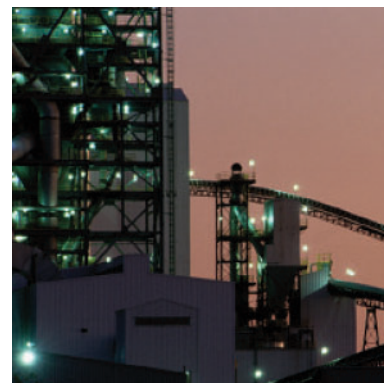



IEC ratings. Recommended motor and type unit ratings

	Light Duty	NORMAL DUTY (IEC Class 10)				HEAVY DUTY (IEC Class 20)				Cat. No.	Ref. No.			
		Max Current Rating	Rated Current	400V-230V	480V-415V	480V-500V	690V	Rated Current	400V-230V			480V-415V	480V-500V	690V
		A	A	kW	kW	kW	kW	A	kW			kW	kW	kW
Mains voltage 230-500VAC	8	8	1.5	3	4	-	8	1.5	3	4	-	QT10008U21MS	169075	
	17	17	4	7.5	7.5	-	12	3	5.5	5.5	-	QT10017U21MS	169076	
	34	31	7.5	15	18.5	-	31	7.5	15	18.5	-	QT10031U21MS	169077	
	54	44	11	22	30	-	44	11	22	30	-	QT10044U21MS	169078	
	65	58	15	30	37	-	55	15	30	37	-	QT10058U21MS	169079	
	72	72	22	37	45	-	66	18.5	37	45	-	QT10072U21MS	169080	
	104	85	22	45	55	-	80	22	45	55	-	QT10085U21MS	169081	
	130	105	30	55	55	-	99	30	55	55	-	QT10105U21MS	169082	
	156	145	45	75	90	-	130	37	55	90	-	QT10145U21MS	169083	
	170	170	55	90	110	-	134	37	75	90	-	QT10170U21MS	169084	
	248	210	55	110	132	-	203	55	110	132	-	QT10210N21MS	169091	
	361	310	90	160	200	-	310	75	160	200	-	QT10310N21MS	169092	
	390	390	110	200	250	-	344	110	160	250	-	QT10390N21MS	169093	
	480	460	132	250	315	-	432	132	250	315	-	QT10460N21MS	169094	
	610	580	160	315	400	-	488	160	250	355	-	QT10580N21MS	169095	
	610	580	160	315	400	-	552	160	315	400	-	QT10580U21MS	169089	
	820	650	200	355	400	-	552	160	315	400	-	QT10650N21MS	169096	
820	820	250	400	560	-	690	200	400	500	-	QT10820U21MS	169090		
1180	950	315	560	630	-	950	315	560	630	-	QT10950N21MS	169097		
1375	1100	355	630	800	-	1076	355	630	800	-	QT11100N21MS	169098		
1750	1400	400	800	1000	-	1400	400	800	1000	-	QT11400N21MS	169099		
Mains voltage 690VAC	8	8	-	-	-	5.5	8	-	-	-	5.5	QT30008N21MS	169119	
	17	17	-	-	-	15	12	-	-	-	7.5	QT30017N21MS	169120	
	34	31	-	-	-	22	31	-	-	-	22	QT30031N21MS	169121	
	54	44	-	-	-	37	44	-	-	-	37	QT30044N21MS	169122	
	65	58	-	-	-	55	55	-	-	-	45	QT30058N21MS	169123	
	72	72	-	-	-	55	66	-	-	-	55	QT30072N21MS	169124	
	104	85	-	-	-	75	80	-	-	-	75	QT30085N21MS	169125	
	130	105	-	-	-	90	99	-	-	-	90	QT30105N21MS	169126	
	156	145	-	-	-	132	130	-	-	-	90	QT30145N21MS	169127	
	170	170	-	-	-	160	134	-	-	-	132	QT30170N21MS	169128	
	248	210	-	-	-	200	203	-	-	-	200	QT30210N21MS	169129	
	361	310	-	-	-	250	310	-	-	-	250	QT30310N21MS	169130	
	390	390	-	-	-	355	344	-	-	-	315	QT30390N21MS	169131	
	480	460	-	-	-	400	432	-	-	-	400	QT30460N21MS	169132	
	610	580	-	-	-	560	488	-	-	-	400	QT30580N21MS	169133	
	820	650	-	-	-	630	552	-	-	-	560	QT30650N21MS	169134	
	1180	950	-	-	-	900	950	-	-	-	900	QT30950N21MS	169135	
1375	1100	-	-	-	1000	1076	-	-	-	1000	QT31100N21MS	169136		
1750	1400	-	-	-	1400	-	-	-	-	-	QT31400N21MS	169137		

**Remark**  
 Motor kW ratings given in above table are for IEC, standard AC four poles motors.  
 Always check that motor rated current is less than the specified rated current of the starter, for the specific application (Normal Duty or Heavy Duty)



QT10008U21MS  
ASTAT XT 8A-72A



QT10105U21MS  
ASTAT XT 105A-170A



QT10210N21MS  
ASTAT XT 210A-390A



QT10460N21MS  
ASTAT XT 460A-650A



**NEMA ratings. Recommended unit type and motor ratings**

	LIGHT DUTY Nema 10				NORMAL DUTY Nema 20				HEAVY DUTY Nema 30				Cat. No.	Ref. No.
	Current Rating		Current Rating		Current Rating		Current Rating		Current Rating		Current Rating			
	230V	460V	575V	230V	460V	575V	230V	460V	575V	230V	460V	575V		
Mains voltage 230-500VAC	A	HP	HP	HP	A	HP	HP	HP	A	HP	HP	HP		
	8	2	5	-	8	2	5	-	8	2	5	-	QT10008U21MS	169075
	17	5	10	-	17	5	10	-	12	3	7.5	-	QT10017U21MS	169076
	34	10	25	-	31	10	20	-	31	10	20	-	QT10031U21MS	169077
	54	20	40	-	44	15	30	-	44	15	30	-	QT10044U21MS	169078
	65	20	50	-	58	20	40	-	55	20	40	-	QT10058U21MS	169079
	72	25	50	-	72	25	50	-	66	20	50	-	QT10072U21MS	169080
	104	40	75	-	85	30	60	-	80	30	60	-	QT10085U21MS	169081
	130	50	100	-	105	40	75	-	99	40	75	-	QT10105U21MS	169082
	156	60	125	-	145	50	100	-	130	50	100	-	QT10145U21MS	169083
	170	60	125	-	170	60	125	-	134	50	100	-	QT10170U21MS	169084
	262	100	200	-	210	75	150	-	203	75	150	-	QT10210U21MS	169085
	387	150	300	-	310	100	250	-	310	100	250	-	QT10310U21MS	169086
	414	150	350	-	390	150	300	-	361	150	300	-	QT10390U21MS	169087
	480	200	400	-	460	150	350	-	432	150	350	-	QT10460U21MS	169088
	610	250	500	-	580	200	400	-	552	200	400	-	QT10580U21MS	169089
	820	-	-	-	820	250	500	-	690	250	500	-	QT10820U21MS	169090
Mains voltage 460-600VAC	8	-	5	5	8	-	5	5	8	-	5	5	QT20008U21MS	169100
	17	-	10	15	17	-	10	15	12	-	7.5	10	QT20017U21MS	169101
	34	-	25	30	31	-	20	25	31	-	20	25	QT20031U21MS	169102
	54	-	40	50	44	-	30	40	44	-	30	40	QT20044U21MS	169103
	65	-	50	60	58	-	40	50	55	-	40	50	QT20058U21MS	169104
	72	-	50	60	72	-	50	60	66	-	50	60	QT20072U21MS	169105
	104	-	75	100	85	-	60	75	80	-	60	75	QT20085U21MS	169106
	130	-	100	125	105	-	75	100	99	-	75	100	QT20105U21MS	169107
	156	-	125	150	145	-	100	150	130	-	100	125	QT20145U21MS	169108
	170	-	125	150	170	-	125	150	134	-	100	125	QT20170U21MS	169109
	262	-	200	250	210	-	150	200	203	-	150	200	QT20210U21MS	169110
	387	-	300	400	310	-	250	300	310	-	250	300	QT20310U21MS	169111
	414	-	350	400	390	-	300	400	361	-	300	300	QT20390U21MS	169112
	480	-	400	500	460	-	350	400	432	-	350	400	QT20460U21MS	169113
	610	-	500	-	580	-	400	400	552	-	400	500	QT20580U21MS	169114
	820	-	-	-	820	-	500	500	690	-	500	-	QT20820U21MS	169115

**Remark**  
 Motor HP ratings given in above table are for NEMA, standard AC four poles motors.  
 Always check that motor rated current is less than the specified rated current of the starter, for the specific application (Light duty, Normal duty or Heavy duty)

Digital soft starters

Intro

A

B

C

D

E

F

G

H

I

J/X



Unit configuration

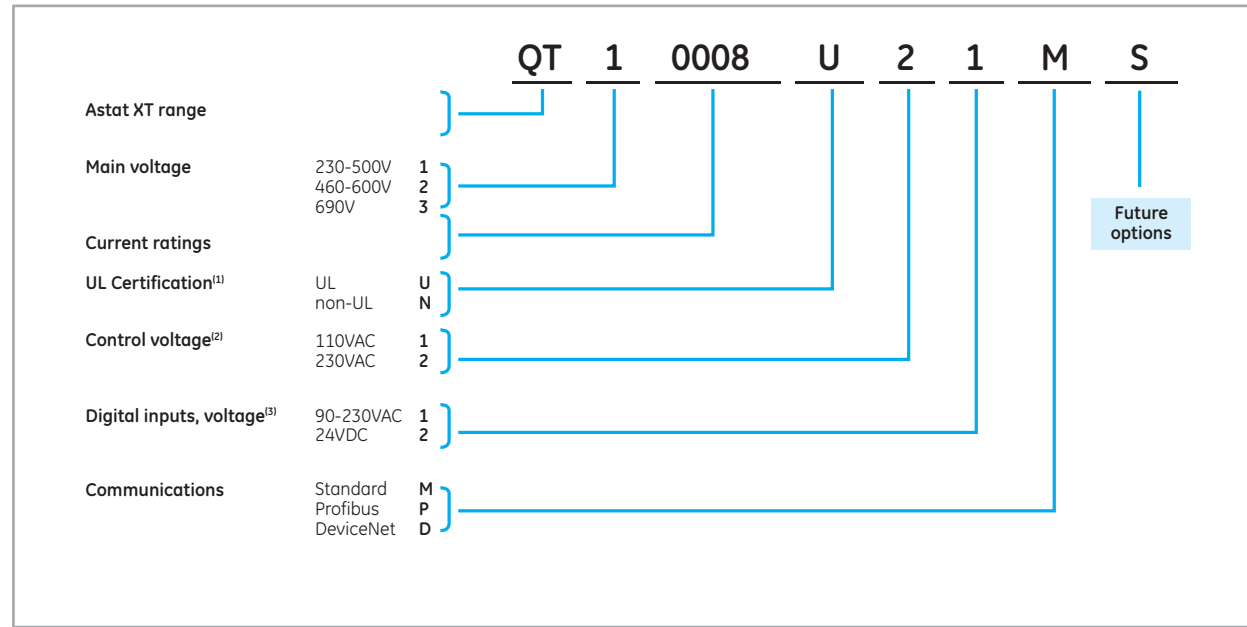

(1) - ASTAT XT up to 600V, and up to 170A (Cat Numbers up to QT10170\_ or up to QT20170) are always cUL certified. Option "N" not available  
 - Units QT2, from QT20008\_ up to QT20820\_ are always cUL certified. Option "N" not available.  
 - Units QT1, or QT2 from QTx0950\_ up to QTx1400 are not UL certified. Option "U" not available.  
 - Units QT3\_ rated to 690V, are not UL certified. Option "U" not available  
 (2) ASTAT XT standard Control Voltage configuration is option 2, Voltage 230VAC, +10%, -15%  
 (3) ASTAT XT standard configuration for Inputs is option 1, Voltage 90-230VAC, +10%, -15%

Soft starters

Intro

A

B

C

D

E

F

G

H

I

J/X



Technical data

Ratings

Main voltage	3Ph AC supply	230 to 500VAC +10%, -15% for QT1xxx units 460 to 600VAC +10%, -15% for QT2xxx units 690VAC +10%, -15% for QT3xxx units
Starter current rating	for 3Ph AC motors	From 8A up to 1400A.
Motor current rating	3 phases Induction motors	Motor rated current from 50% to 100% of starter current
Control voltage	1ph AC supply	230VAC, +10, -15%, 50/60Hz, or 110VAC, +10, -15%, 50/60Hz (optional)
Frequency range	50/60Hz systems	Wide from 45Hz to 65Hz. Auto-tracking frequency range

Control specifications

Control system	Digital control with microcontroller. Starting ramp, with progressive increase in voltage and current limitation	
Operation mode	In-Line (three wires) or Inside-Delta (six wires) of the motor	
Run operation	Soft Start and Soft stop by multiple choices, including torque control both at start or Stop phases	
Operator interface	By LCD display, keypad and Indication LEDs Display: LCD with two rows, 16 characters each Type: Multilanguage, dip-switch selectable for English, Italian, Spanish and German Keys: Six keys, Mode, reset, Set, Select and Up / Down LEDs: ON, Start, Run, Soft Stop, Stop, Save / Slow Speed, Dual Set / Reverse and Fault	
Initial voltage	10-50% Un. Up to 80% with expanded settings function	
Starting current	100-400% In. Can be extended up to 500%, by using extended settings	
Acceleration ramp time	1-30 sec. Can be extended up to 90sec, by using extended settings	
Deceleration ramp time	1-30 sec. Can be extended up to 90sec, by using extended settings	
Current limitation	100-400% of motor rated current. Can be extended up to 500% by using extended settings	
Bypass	By external contactor while motor is full protected by ASTAT XT.	
Monitoring	Motor Current, Line Voltage, motor thermistor resistance, Test & Maintenance and Statistics	

Environmental conditions

Operating temperature	-10 up to 50°C, with current derating by 2.5% per °C, from 40°C
Storage temperature	-20°C up to 70°C
Maximum altitude	Up to 1000 mts. Ask your dealer for installation at higher altitude
Humidity	95% at 50°C or 98% at 45°C
Protection degree	IP20 for units up to 72A, IP00 for units from 85A up to 1400A
Pollution degree	Class 3

Standards

Global standards	CE for the full range. UL, cUL for specified units up to 820A
EMC emissions	EN 61000-6-4 CISPR 11 Class A
Immunity	EN 61000-6-2 ESD 8KV air, IEC 801-2; Electric RF field 10 V/m, 20-1000Mhz, IEC 801-3 Fast transients 2KV, IEC 801-4
Safety	EN 600947-1 Related to safety requirements. UL508C



Digital soft starters

Intro

A

B

C

D

E

F

G

H

I

J/X



Functions

Available standard functions

Soft start and soft stop	ASTAT XT is provided with a soft start and soft stop features, including five independent acceleration and deceleration curve models. The factory default curve is used for general purpose, other three are used for pump control and the last one for torque control.
Pump control	Specific function for pump control, that avoids overpressure in the system at the end of acceleration phase and suppresses the hammering at stopping phase.
Torque control	Provides a smooth time controlled torque ramp acceleration and deceleration, with linear deceleration of the torque resulting in a close to linear speed deceleration, thus eliminating stall conditions
In line / Inside delta	ASTAT XT allows either traditional Line operation or Inside Delta operation. When the ASTAT XT is installed to operate Inside Delta, the individual phases of the starter are connected in series with the individual motor windings (six wiring connections like the Start-Delta starters), thus reducing the current x1.73, and allowing the use of a much smaller starter (x1.5 less than motor rated current).
Bypass	ASTAT XT allows bypass operation using an external contactor, controlled ON/OFF by starter function EOR (End Of Ramp). The starter is provided with three dedicated power terminals to facilitate wirings to the bypass contactor. ASTAT XT protections to motor are enabled, even in bypass.
Kick start	This function allows to start high friction loads that require high starting torque for a short period of time. When this function is enabled, a pulse of 80% Un during an adjustable time from 0 to 1sec is given to the motor. After this pulse the output voltage is ramping down to Starting Voltage setting, before ramping up again to full voltage.
End of ramp	Detects end of acceleration and outputs a signal by an dry relay contact. This signal can be delayed by an adjustable timer from 0-120 sec.
Lock-Out	Allows to control the number of startings into a period of time, then protecting both motor and ASTAT.
Dual settings	By this function, ASTAT XT is able to control a secondary motor Dual setting of Starting Voltage, Starting Current, Current Limit, Ramp Up, Ramp Down and Motor current parameters can be selected by using one of the programmable ASTAT XT's inputs
Energy saving	Activated when the motor has a light load for extended periods of time, then reducing the output voltage level and decreasing the reactive current and motor copper/iron losses. This function can be enabled or disabled by dedicated parameters in ASTAT XT.
Slow speed	Function that allows the motor to run at 1/6 constant rated speed, for a short period of time of maximum 30sec. This function supports forward and reverse operation.
Auto reset	This function allows the ASTAT XT automatic recover after a fault caused by Undervoltage, Undercurrent or Phase lost. Auto-Reset can be programmed up to maximum 10 attempts.
Cooling fan control	Allows three methods of control for the ASTAT's built-in cooling fans. - Continuous Operation - Controlled by an external Input - Automatically OFF controlled, after five minutes ASTAT XT is stopped
Generator supply	This is a specific function useful when the Starter is powered from a diesel generator rather than from commercial power supply. The function is enabled by an internal Dip Switch, and helps to minimize the negative effects caused by the generator's voltage fluctuations during starting.
Keypad lock	This function is enabled by means of starter's internal dipswitch, then locking the keypad. This is useful to prevent undesired parameter modifications.
Built-in communications	ASTAT XT includes a ModBus RTU communications protocol. Communications are carried out through a half duplex RS485 port, with maximum baudrate of 9600, supporting up to 247 stations.
Statistic data	ASTAT XT records useful data for maintenance and start up - Last 10 trip events - Statistical data like number of starts, number of trip events and elapsed RUN time. - Last trip data information of Motor current, Starting current and acceleration time.

Motor and starter protection

Overload	Trips the ASTAT-XT when current exceeds the Overload Trip level according IEC Class 10, 20 or NEMA 10, 20, 30
Motor thermistor	Trips when motor thermistor resistance decreases below trip level set ASTAT XT allows both PTC or NTC sensors, with adjustable trip level
Too many starts	Trips if the number of starts, during Duty Cycle Time exceeds the preset number
Long start time	Trips if output voltage does not reach rated voltage at the preset Max. Start time
O/C JAM fault	Trips under the following conditions: - Instantaneously when current exceeds 8.5 x ASTAT-XT Current - During starting when current exceeds 8.5 x Motor Current - During running when current exceeds 200-850% of Motor Current O/C JAM has a programmable tripping delay of 0-5 seconds
Undercurrent	Trips when line current drops below the preset level for the preset time.
Undervoltage	Trips when line voltage drops below the preset level for the preset time.
Overvoltage	Trips when line voltage increases above a preset level for a preset time
Phase loss	Trips if 1 or 2 phases are lost
Frequency loss	Trips if frequency is not in the range of 40-66.6Hz
Phase sequence	Trips if line phase sequence is wrong
Slow speed time	Trips when operating at slow speed for extended periods
Wrong connection	Trips the ASTAT-XT when one or more motor phases is not properly connected to ASTAT-XT's load terminals or if there is an internal disconnection in the motor winding
Shorted SCR	Trips and prevents starting if any SCR is short-circuited or when motor windings are shorted
Over temperature	Heat-sink over-temperature. Trips the ASTAT-XT when the heat-sink temperature rises above 85°C
External fault	Trips the ASTAT-XT when a N.O. contact between terminals 19-21 closes for over two seconds
Wrong parameters	Parameters not transferred from RAM to EEPROM or vice versa
OC or wrong CON	Trips when the ASTAT-XT is connected Inside Delta and Wrong connection or overcurrent is detected



### Overload protections - Thermal characteristics

The ASTAT XT allows motor protection according IEC Class 10 or Class 20 and NEMA 10, 20 or 30, user free selectable by ASTAT internal dedicated parameter.

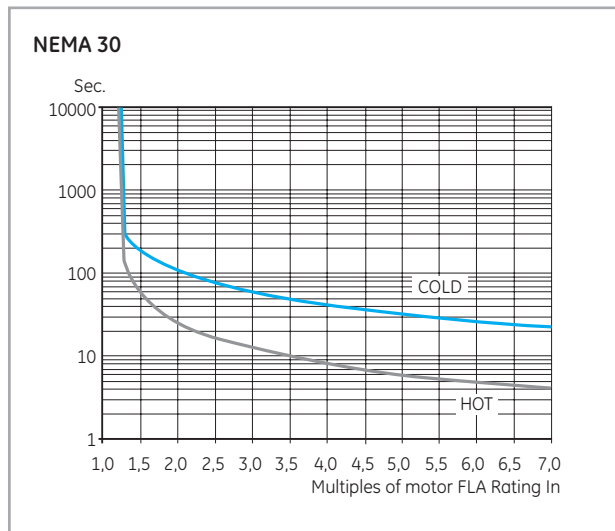
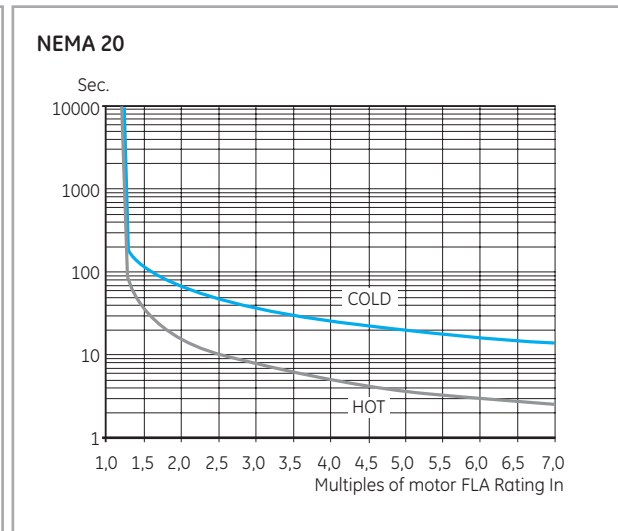
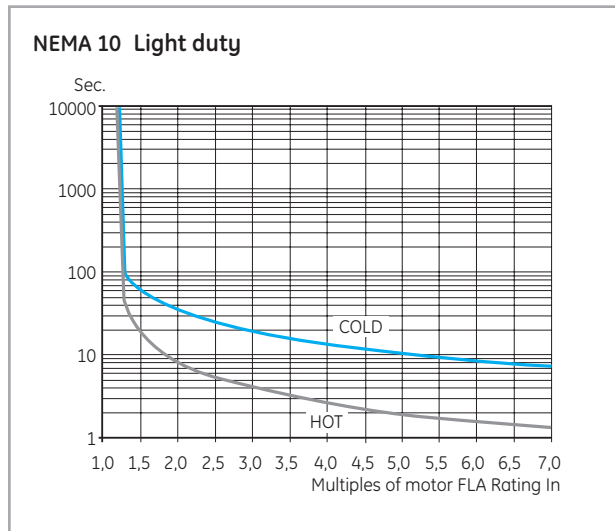
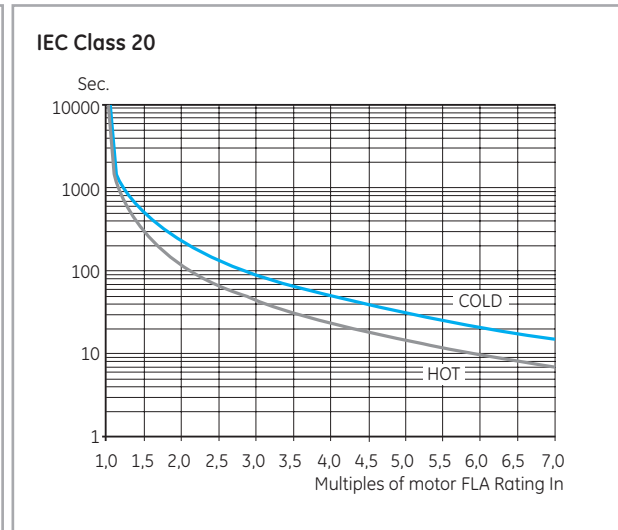
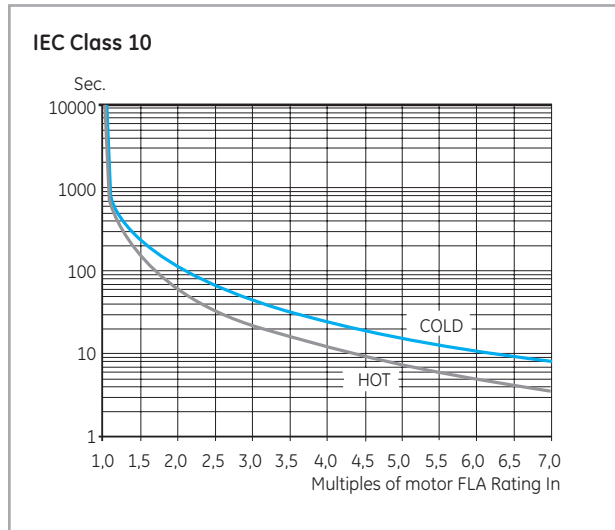

#### Maximum number starting /hour

Starting current I/In <sup>(1)</sup>	Ramp time		
	10s	20s	30s
2	24	12	8
3	16	8	5
4	12	6	4

(1) In= rated current of ASTAT XT in the specified class IEC/Nema

Digital soft starters

Intro

A

B

C

D

E

F

G

H

I

J/X



I/O Wiring, Basic scheme

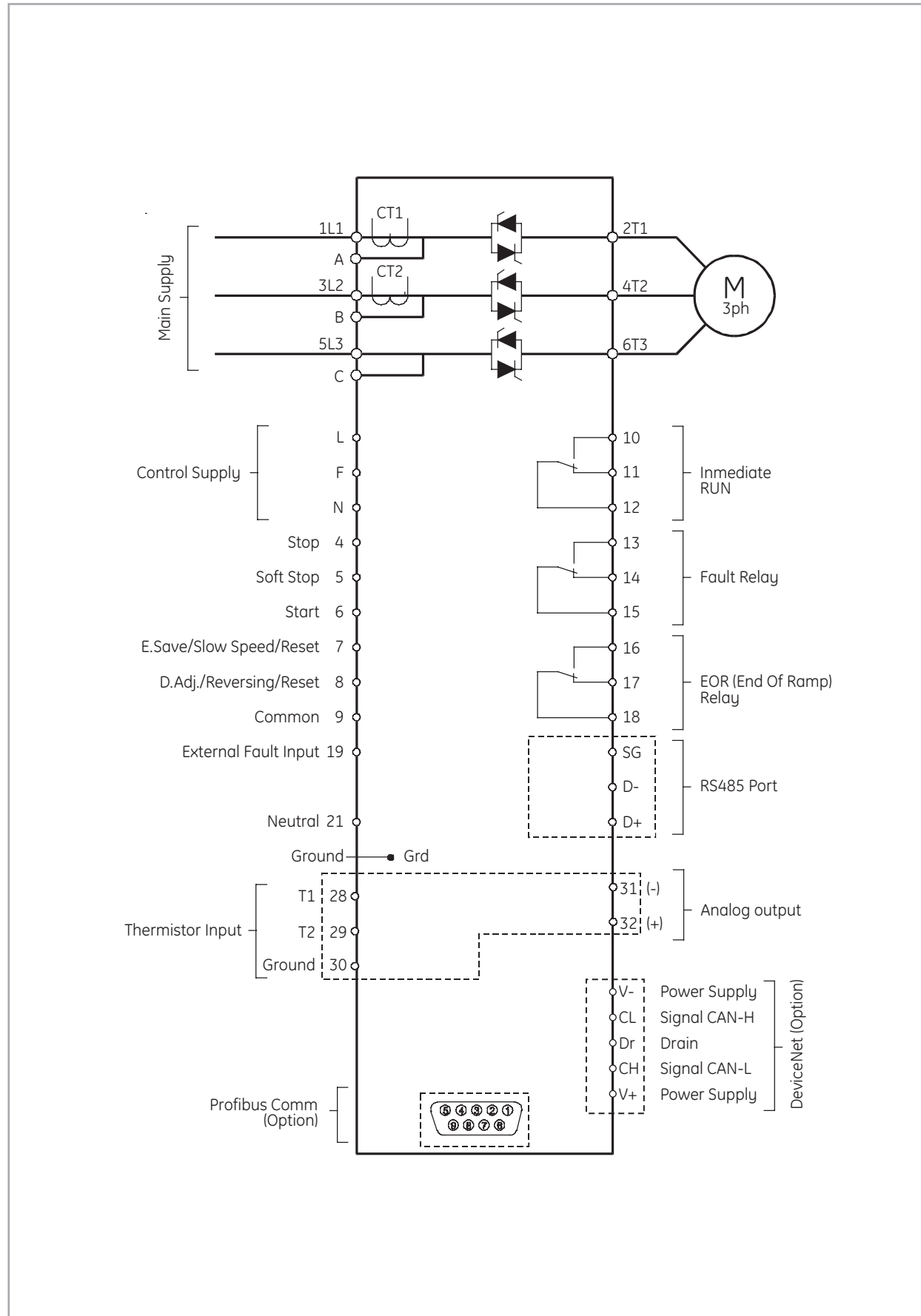

- Soft starters
- Intro
- A
- B
- C
- D
- E
- F
- G
- H
- I
- J/X



## I/O terminal board specifications

### Power I/O terminals

Terminals	Function	Description
1L1, 3L2, 5L3	Mains Input	3ph Input voltage according Astat XT Main Voltage Option rating (Option 1, QT1 ) 230-500VAC, +10%/-15% 50/60Hz (Option 2, QT2 ) 460-600VAC, +10%/-15% 50/60Hz (Option 3, QT3 ) 690VAC, +10%/-15% 50/60Hz
2T1, 4T2, 6T3	Output to motor	Power Output terminals to 3ph AC motor
A, B, C	By-pass	Bypass terminals for external by-pass contactor
G	Ground	ASTAT XT, ground connection

### Control power supply

L, N	Control Supply	110VAC or 220VAC, according ASTAT XT Control Voltage rating
F	Fan control	Cooling fan external control, together with jumper J1
		<b>Control Voltage &amp; Fan consumption VA:</b> QTx0008 to QTx0031: No fan. Total consumption: 150VA QTx0044 to QTx0072: Fan 35 VA. Total consumption 185VA QTx0085 to QTx0170: Fan 60 VA. Total consumption 210VA QTx0210 to QTx0390: Fans 105VA. Total consumption 255VA QTx0390 to QTx 1400A : Fans 150VA.Total consumption 300VA

### Digital inputs

4	Stop	Dedicated input to Stop
5	Soft Stop	Dedicated input to Soft Stop
6	Start	Dedicated input to Start
7	Programmable Inputs	Programmable to functions Energy Saving, Slow Speed and Reset
8	Programmable Inputs	Programmable to functions Dual Set, Reverse and Reset
9	Common	Common terminal for digital inputs from 4, 5, 6, 7 and 8
		<b>Operating Voltage of digital inputs from 4 to 9</b> Digital Input hardware is operated according either of below ordered voltage ratings (Option 1, standard) From 90 to 230VAC +10%, 50/60Hz (Option 2, Optional) 24VDC +10%/-15%

### Other inputs

19, 21	External fault	Requires a free voltage relay contact, to detect external fault
21	Neutral	This terminal may be connected to Mains Neutral when available
28, 29	Motor thermistor	PTC or NTC programable input for motor thermistor protection The input can be enabled or disabled, and programmed at desired trip level resistance

### Digital outputs

10, 11, 12	RUN	Run Relay with NO & NC dry contact. Programmable ON delay
13, 14, 15	FAULT	Fault to ON or Fault to OFF programmable function
16, 17, 18	EOR	End Of Ramp relay. Programmable ON delay
		<b>Relay Outputs Ratings</b> Max rating: 8A, 250VAC, 2000VA max

### Analogue output

31, 32	Current output	Range 0 to 2xIn. Programmable 0-10VDC, 0-20mA or 4-20mA.
30	Ground	Ground terminal for Analog Output

### Communications

D+, D-, SG	RS485 terminals	RS485 Communication port, half duplex for ModBus protocol Baudrate 1200, 2400, 4800, 9600 BPS
D-9 connector	Profibus port	Optional Profibus Communications port
V+, CL, Dr, CH, V-	DeviceNet terminals	Optional DeviceNet Communications port

Digital soft starters

Intro

A

B

C

D

E

F

G

H

I

J/X





Application wiring diagrams

Basic diagram without line contactor<sup>(1)</sup>

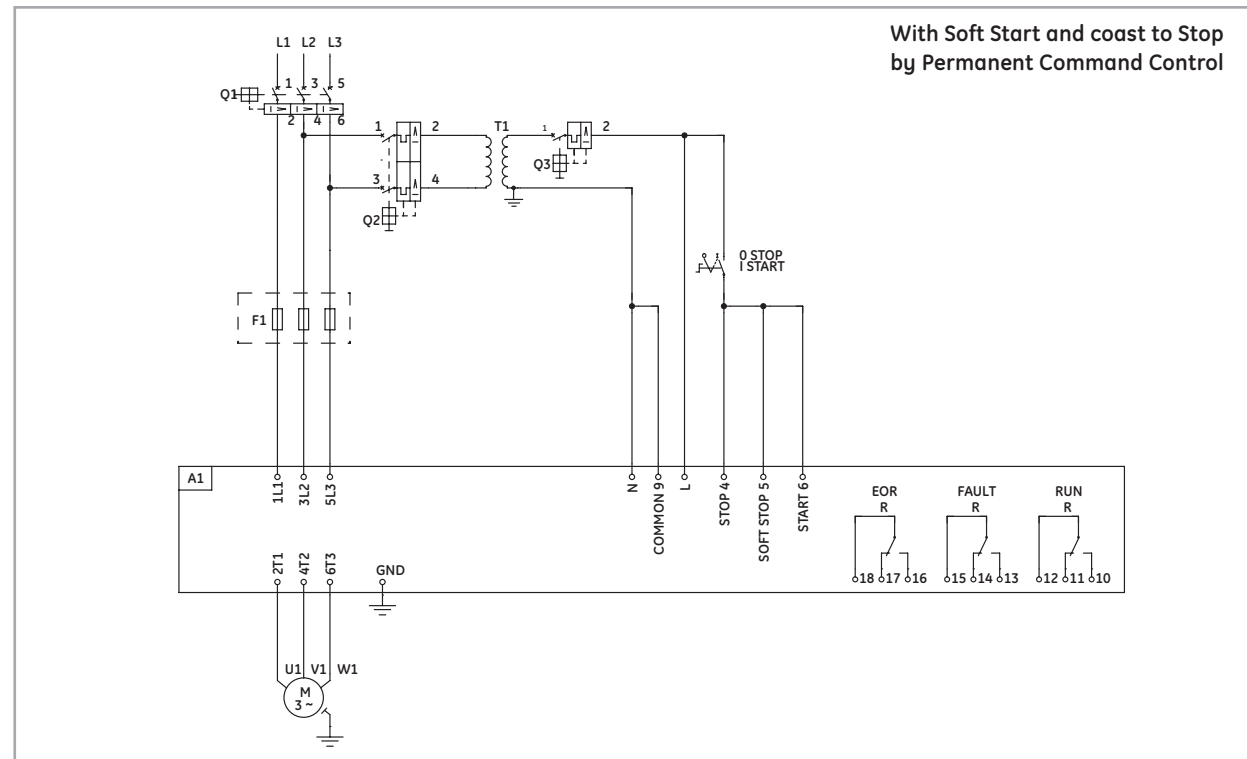

Basic diagram without line contactor<sup>(1)</sup>

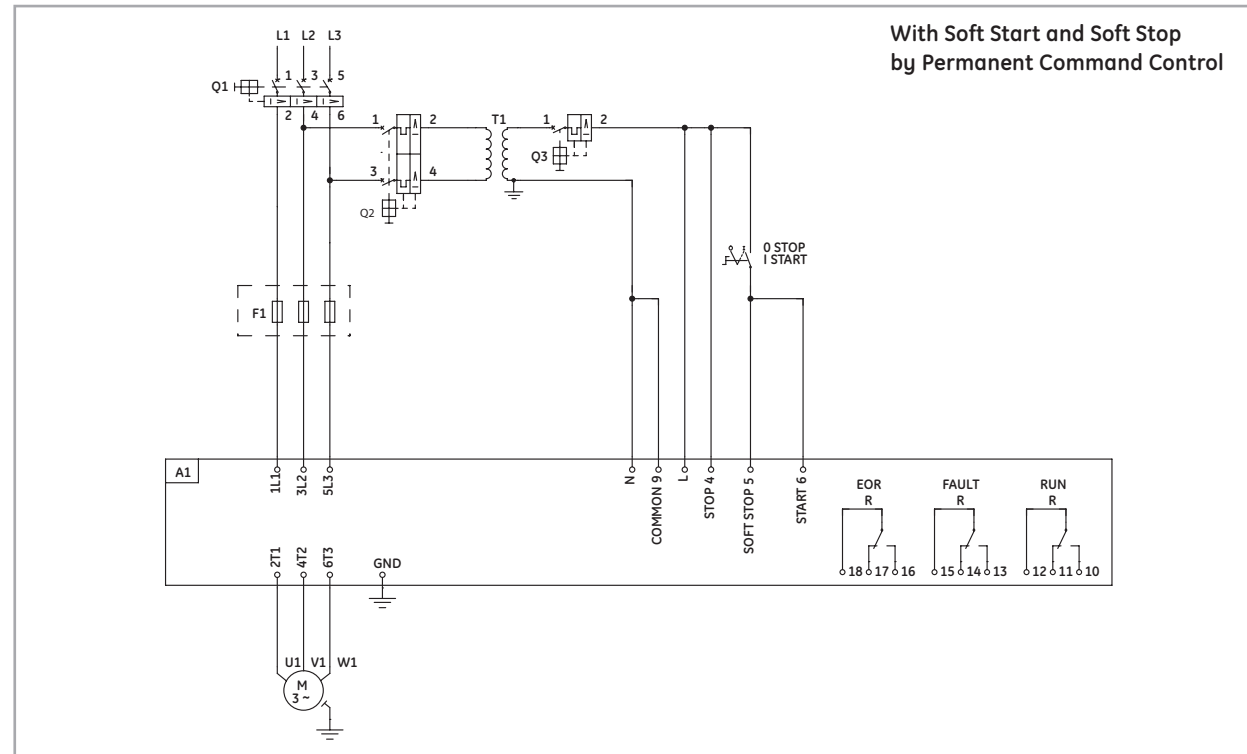

(1) Schemes are given for information purposes. Add additional emergency safety stop, if it is required for your application.

Remarks

1. Check coordination tables for proper selection of Breaker and Line contactor.
2. Control Voltage and Control Input voltage are from same source in above example. Please check manuals if you have different sources for Control Voltage and Control input Voltage.
3. Semiconductor Fuses "F" are only required for Type 2 coordination. Please check coordination tables
4. In spite of ASTAT XT can operate without line contactor, the use of a line contactor will increase the operation safety. Anyway provide a way to switch off the Breaker in case of an emergency.

Application wiring diagrams

Basic diagram without line contactor<sup>(1)</sup>

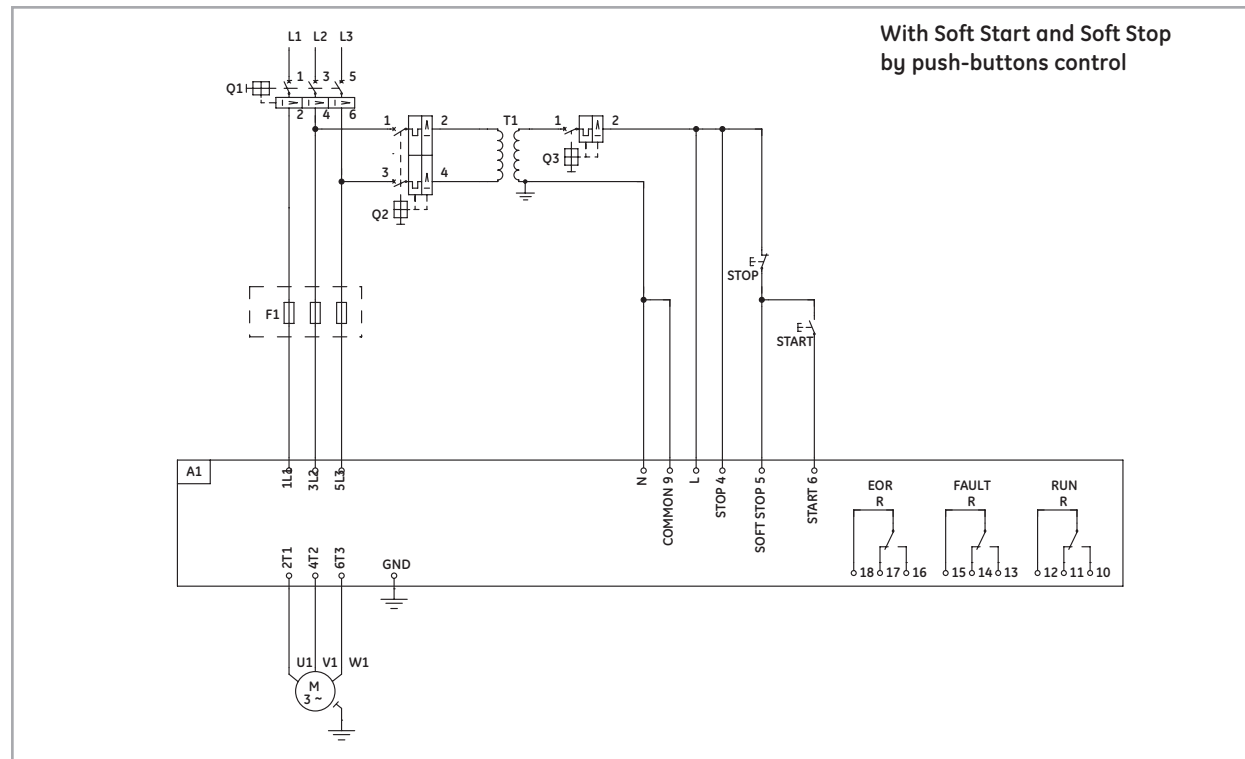

Basic diagram with line contactor<sup>(1)</sup>

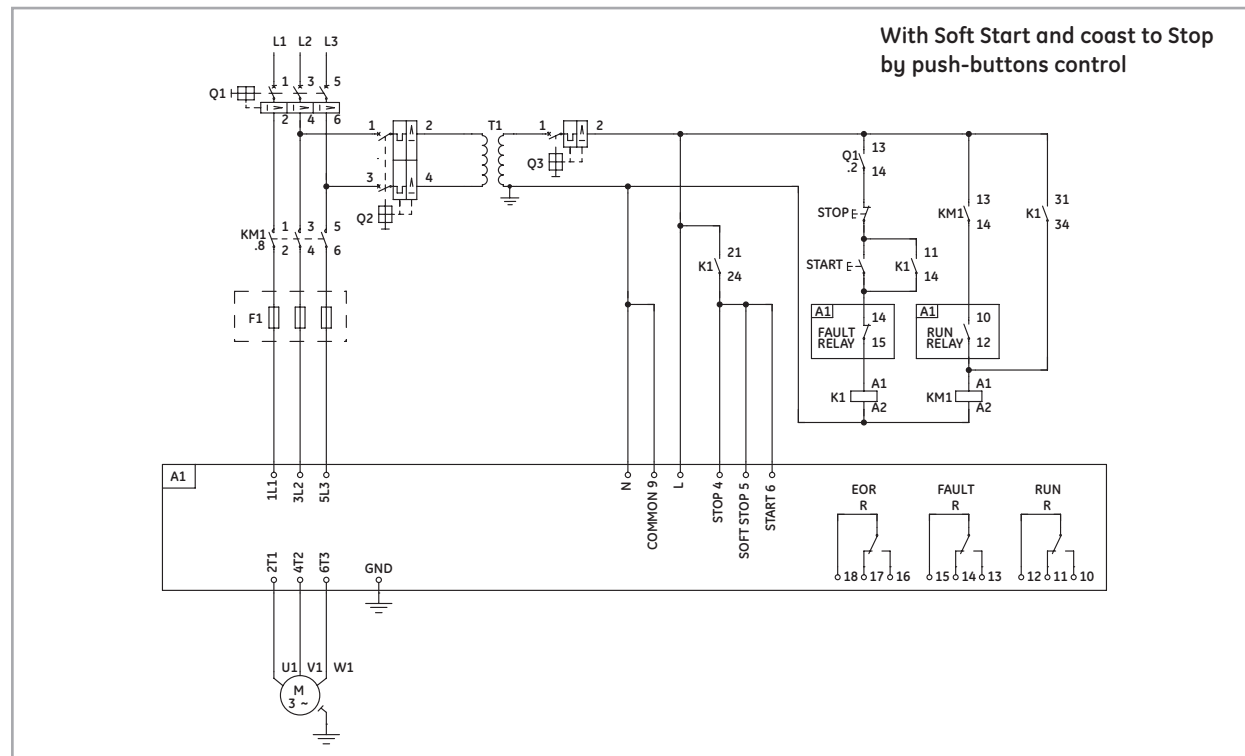

(1) Schemes are given for information purposes. Add additional emergency safety stop, if it is required for your application.

Remarks

1. Check coordination tables for proper selection of Breaker and Line contactor.
2. Control Voltage and Control Input voltage are from same source in above example. Please check manuals if you have different sources for Control Voltage and Control input Voltage.
3. Semiconductor Fuses "F" are only required for Type 2 coordination. Please check coordination tables
4. In spite of ASTAT XT can operate without line contactor, the use of a line contactor will increase the operation safety. Anyway provide a way to switch off the Breaker in case of an emergency.

Digital soft starters

Intro

A

B

C

D

E

F

G

H

I

J/X



Application wiring diagrams

Basic diagram with line contactor<sup>(1)</sup>

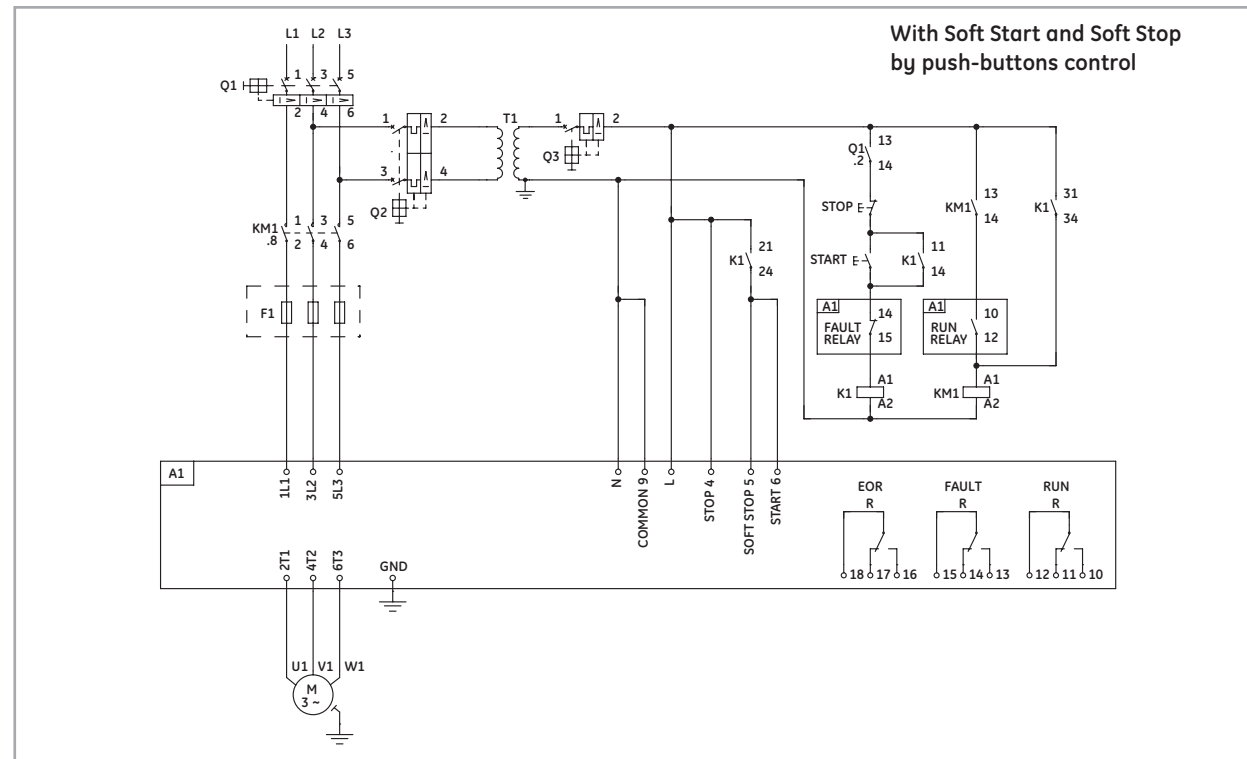

Basic diagram with line and bypass contactors<sup>(1)</sup>

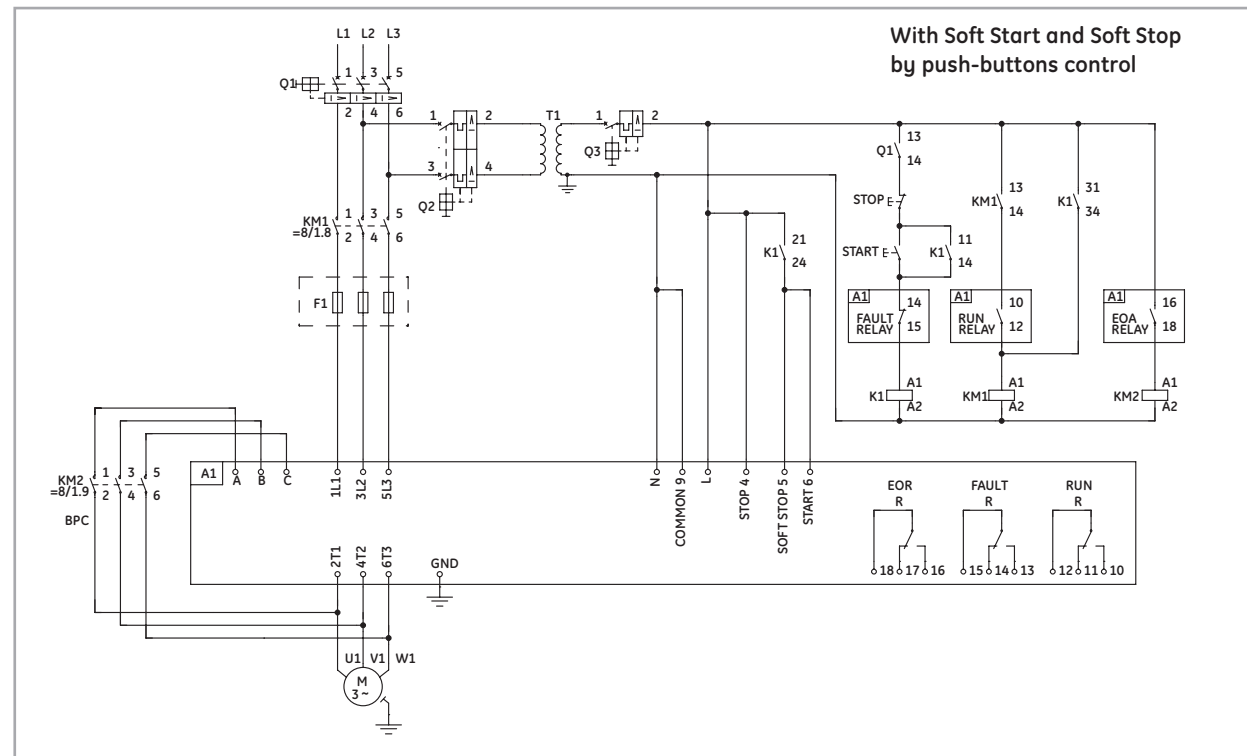

(1) Above schemes are given for information purposes. Add additional emergency safety stop, if it is required for your application.

Remarks

1. Check coordination tables for proper selection of Breaker and Line contactor.
2. Control Voltage and Control input voltage are from same source in above example. Please check manuals if you have different sources for Control Voltage and Control input Voltage.
3. Semiconductor Fuses "F" are only required for Type 2 coordination. Please check coordination tables

Application wiring diagrams

Basic diagram in "Inside Delta" configuration with line and bypass contactors<sup>(1)</sup>

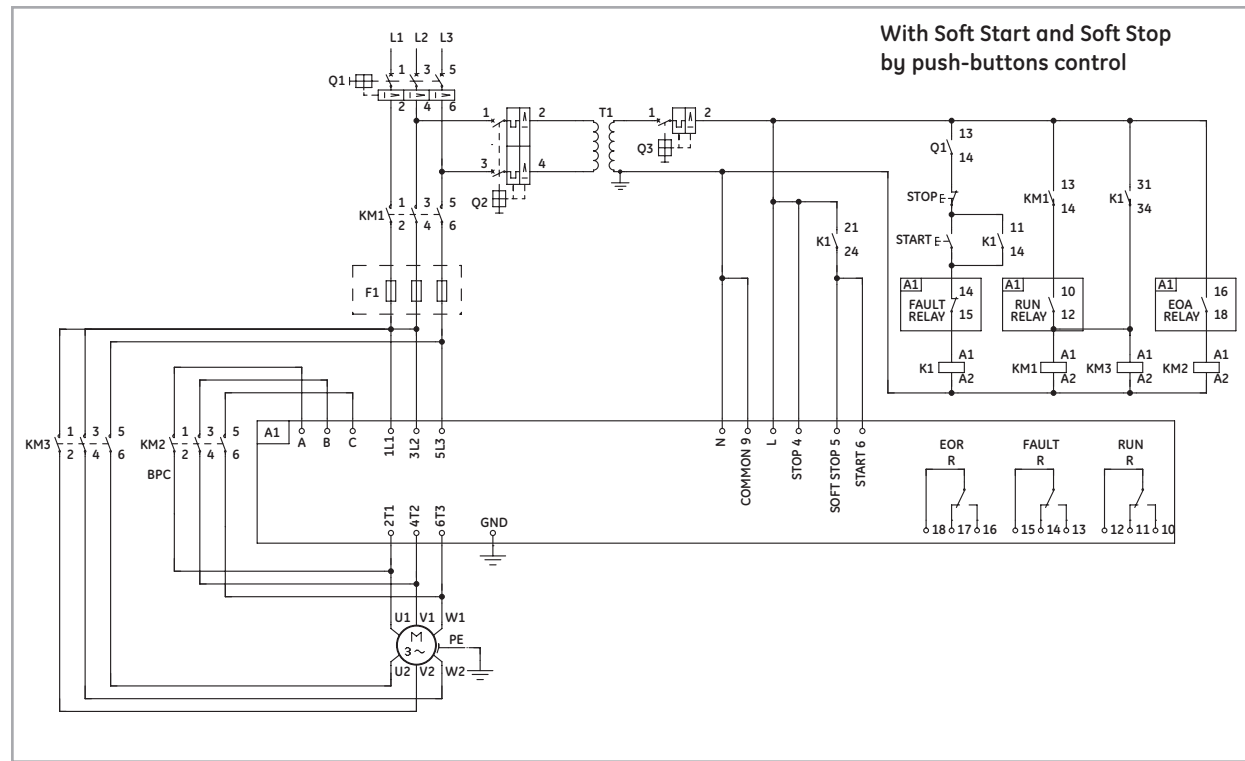

(1) Above schemes are given for information purposes. Add additional emergency safety stop, if it is required for your application.

Remarks

1. Check coordination tables for proper selection of Breaker and Line contactor.
2. Control Voltage and Control Input voltage are from same source in above example. Please check manuals if you have different sources for Control Voltage and Control input Voltage.
3. Semiconductor Fuses "F" are only required for Type 2 coordination. Please check coordination tables
4. Wrong connection of the motor, or the ASTAT-XT when it is Inside-delta connected may seriously damage the motor or the ASTAT-XT. Please check additional details given in the ASTAT XT's instruction manual.

Digital soft starters

Intro

A

B

C

D

E

F

G

H

I

J/X



Coordination Type 1

Combination with aM fuses - 415V

Main Voltage Up to 415VAC	Rating (A)	ASTAT-XT type		aM fuses		Contactor Type	Short-circuit current
		Cat. No.		Rating (A)		CL/CK series	Iq (kA)
	8	-	QT10008	-	16	CL00	80
	17	-	QT10017	-	20	CL02	80
	31	-	QT10031	-	35	CL04	80
	44	-	QT10044	-	50	CL06	80
	58	-	QT10058	-	80	CL07	80
	72	-	QT10072	-	100	CL08	80
	85	-	QT10085	-	125	CL09	80
	105	-	QT10105	-	160	CL10	80
	145	-	QT10145	-	200	CK75C	80
	170	-	QT10170	-	200	CK08C	80
	210	-	QT10210	-	250	CK09B	80
	310	-	QT10310	-	400	CK95B	80
	390	-	QT10390	-	500	CK10C	80
	460	-	QT10460	-	630	CK11C	80
	580	-	QT10580	-	800	CK12B	80
	650	-	QT10650	-	1000	CK13B	80
	950	-	QT10950	-	2x630	-	80
	1100	-	QT11100	-	2x800	-	80
	1400	-	QT11400	-	2x800	-	80

Combination with Record Plus MCCB'S - 415V

Main Voltage Up to 415VAC	Rating (A)	ASTAT-XT type		Circuit Breaker		Contactor Type	Short-circuit current
		Cat. No.	Record Plus	Rating (A)		CL/CK series	Iq (kA)
	8	-	QT10008	FD63	16	CL45	65
	17	-	QT10017	FD63	40	CL06	65
	31	-	QT10031	FD63	50	CL06	65
	44	-	QT10044	FD160	63	CL06	65
	58	-	QT10058	FD160	80	CL07	65
	72	-	QT10072	FD160	80	CL08	65
	85	-	QT10085	FE160	125	CL10	65
	105	-	QT10105	FE160	160	CL10	65
	145	-	QT10145	FE160	160	CK85B	65
	170	-	QT10170	FE250	160	CK08	65
	210	-	QT10210	FE250	160	CK85	65
	310	-	QT10310	FG400	400	CK10C	65
	390	-	QT10390	FG400	400	CK12B	65
	460	-	QT10460	FG630	630	CK12B	65
	580	-	QT10580	FG630	630	CK13B	65
	650	-	QT10650	FK1250	1000	CK13B	50
	950	-	QT10950	FK1250	1000	-	50
	1100	-	QT11100	FK1250	1250	-	50
	1400	-	QT11400	FK1600	1600	-	50

Combination with aM fuses - 500V

Main Voltage 500 VAC	Rating (A)	ASTAT-XT type		aM fuses		Contactor Type	Short-circuit current
		Cat. No.		Rating (A)		CL/CK series	Iq (kA)
	8	QT10008	QT20008	-	16	CL00	80
	17	QT10017	QT20017	-	20	CL02	80
	31	QT10031	QT20031	-	35	CL04	80
	44	QT10044	QT20044	-	50	CL06	80
	58	QT10058	QT20058	-	80	CL07	80
	72	QT10072	QT20072	-	100	CL08	80
	85	QT10085	QT20085	-	125	CL09	80
	105	QT10105	QT20105	-	160	CL10	80
	145	QT10145	QT20145	-	200	CK75C	80
	170	QT10170	QT20170	-	200	CK08C	80
	210	QT10210	QT20210	-	250	CK09B	80
	310	QT10310	QT20310	-	400	CK95B	80
	390	QT10390	QT20390	-	500	CK10C	80
	460	QT10460	QT20460	-	630	CK11C	80
	580	QT10580	QT20580	-	800	CK12B	80
	650/820	QT10650	QT20820	-	1000	CK13B	80
	950	QT10950	QT20950	-	2x630	-	80
	1100	QT11100	QT21100	-	2x800	-	80
	1400	QT11400	QT21400	-	2x800	-	80

Soft starters

Intro

A

B

C

D

E

F

G

H

I

J/X



Coordination Type 2

Combination with semiconductor fuses - 415V

Main Voltage Up to 415VAC	ASTAT-XT type		Semiconductor fuses <sup>(1)</sup>		Contactor Type	Short-circuit current
	Rating (A)	Cat. No.	Bussmann type	CL/CK series	Iq (kA)	
8	-	QT10008	170M3808D	CL25	80	
17	-	QT10017	170M3810D	CL25	80	
31	-	QT10031	170M3813D	CL04	80	
44	-	QT10044	170M3814D	CL45	80	
58	-	QT10058	170M3814D	CL07	80	
72	-	QT10072	170M3815D	CL08	80	
85	-	QT10085	170M3816D	CL09	80	
105	-	QT10105	170M3817D	CL10	80	
145	-	QT10145	170M3817D	CK75C	80	
170	-	QT10170	170M3819D	CK08C	80	
210	-	QT10210	170M4864D	CK09B	80	
310	-	QT10310	170M4864D	CK95B	80	
390	-	QT10390	170M5814D	CK10C	80	
460	-	QT10460	170M5820D	CK11C	80	
580	-	QT10580	170M5816D	CK12B	50	
650	-	QT10650	2x170M5814D	CK13B	80	
950	-	QT10950	2x170M5816D	-	80	
1100	-	QT11100	2x170M6892D	-	80	
1400	-	QT11400	2x170M8555D	-	80	

Combination with semiconductor fuses - 500V

Main Voltage 500 VAC	ASTAT-XT type		Semiconductor fuses <sup>(1)</sup>		Contactor Type	Short-circuit current
	Rating (A)	Cat. No.	Bussmann type	CL/CK series	Iq (kA)	
8	QT10008	QT20008	170M3808D	CL25	80	
17	QT10017	QT20017	170M3810D	CL25	80	
31	QT10031	QT20031	170M3813D	CL04	80	
44	QT10044	QT20044	170M3814D	CL06	80	
58	QT10058	QT20058	170M3814D	CL07	80	
72	QT10072	QT20072	170M3815D	CL08	80	
85	QT10085	QT20085	170M3816D	CL09	80	
105	QT10105	QT20105	170M3817D	CL10	80	
145	QT10145	QT20145	170M3817D	CK75C	80	
170	QT10170	QT20170	170M3819D	CK08C	80	
210	QT10210	QT20210	170M4864D	CK09B	80	
310	QT10310	QT20310	170M4864D	CK10C	80	
390	QT10390	QT20390	170M5814D	CK10C	80	
460	QT10460	QT20460	170M5820D	CK11C	80	
580	QT10580	QT20580	170M5816D	CK12B	50	
650/820	QT10650	QT20820	2x170M5814D	CK13B	80	
950	QT10950	QT20950	2x170M5816D	-	80	
1100	QT11100	QT21100	2x170M6892D	-	80	
1400	QT11400	QT21400	2x170M8555D	-	80	

Combination with semiconductor fuses - 690V

Main Voltage 690 VAC	ASTAT-XT type		Semiconductor fuses <sup>(1)</sup>		Contactor Type	Short-circuit current
	Rating (A)	Cat. No.	Bussmann type	CL/CK series	Iq (kA)	
8	-	QT30008	170M3808D	CL25	50	
17	-	QT30017	170M3810D	CL25	50	
31	-	QT30031	170M3813D	CL06	50	
44	-	QT30044	170M3814D	CL06	50	
58	-	QT30058	170M3814D	CL07	50	
72	-	QT30072	170M3815D	CL08	50	
85	-	QT30085	170M3816D	CK75C	50	
105	-	QT30105	170M3817D	CK75C	50	
145	-	QT30145	170M3817D	CK08B	50	
170	-	QT30170	170M3819D	CK08B	50	
210	-	QT30210	170M4864D	CK08B	50	
310	-	QT30310	170M4864D	CK10C	50	
390	-	QT30390	170M5814D	CK10C	50	
460	-	QT30460	170M5820D	CK12B	50	
580	-	QT30580	170M5816D	CK12B	30	
650	-	QT30650	2x170M5814D	-	50	
950	-	QT30950	2x170M5816D	-	50	
1100	-	QT31100	2x170M6892D	-	50	
1400	-	QT31400	2x170M8555D	-	50	

(1) Semiconductor Fuses must be always used for Type 2 coordination

Digital soft starters

Intro

A

B

C

D

E

F

G

H

I

J/X



Dimensions and weights

Cat. No.: QTx0008U\_, QTx0017U\_, QTx0031U\_, QTx0044U\_, QTx0058U\_, QTx0072U\_

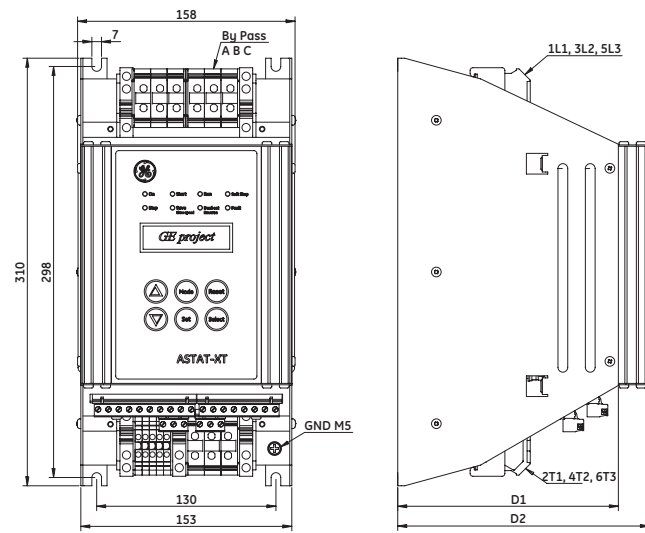

Cat. No	Dimensions		Power terminal size (mm <sup>2</sup> )			Weight Kg
	D1	D2	Input 1L1, 3L2, 5L3	Bypass A, B, C	Output 2T1, 4T2, 6T3	
QTx0008U	160	182.5	16	16	16	4.2
QTx0017U	160	182.5	16	16	16	4.2
QTx0031U	160	182.5	16	16	16	5.3
QTx0044U	207	229.5	16	16	35	6.7
QTx0058U	207	229.5	16	16	35	6.7
QTx0072U	207	229.5	35	35	35	6.7

UL Certified units

Cat. No.: QTx0085U\_, QTx0105U\_

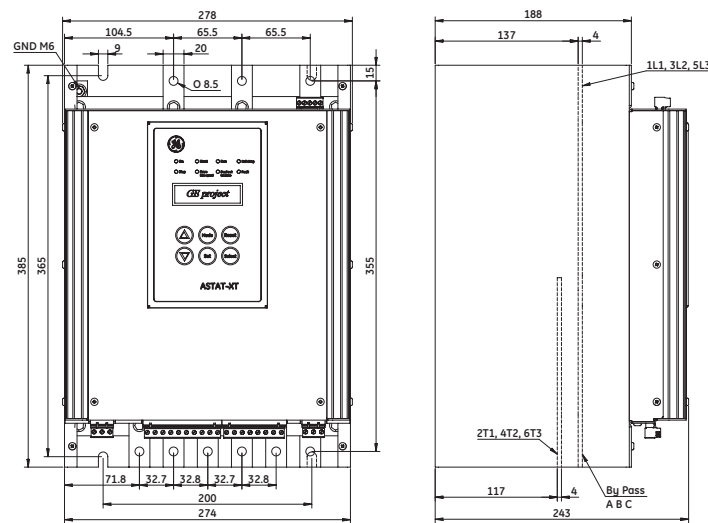

Cat. No.	Weight
QTx0085U	15.2
QTx0105U	15.2

UL Certified units

- Soft starters
- Intro
- A
- B
- C
- D
- E
- F
- G
- H
- I
- J/X



Dimensions and weights

Cat. No.: QTx0145U\_, QTx0170U\_

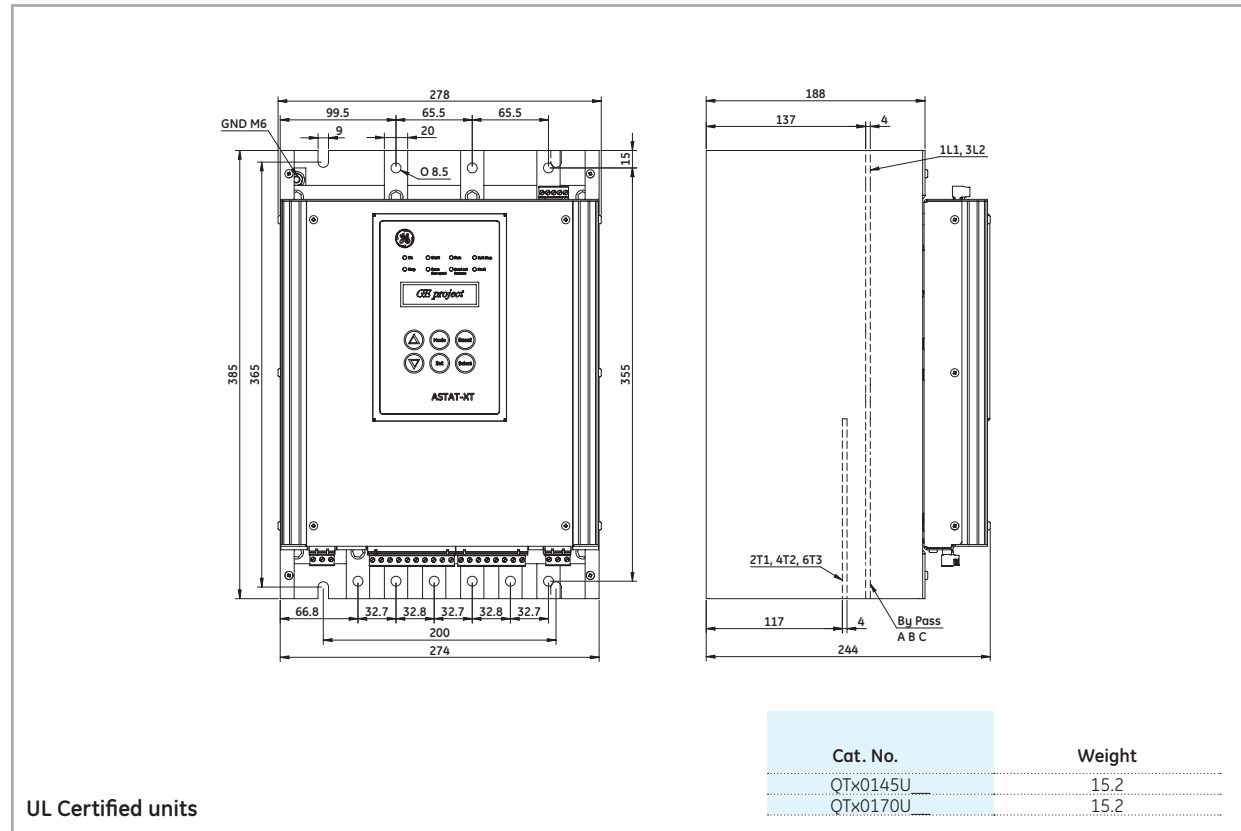

UL Certified units

Cat. No.: QTx0210N\_, QTx0310N\_, QTx0390N\_, QTx0460N\_

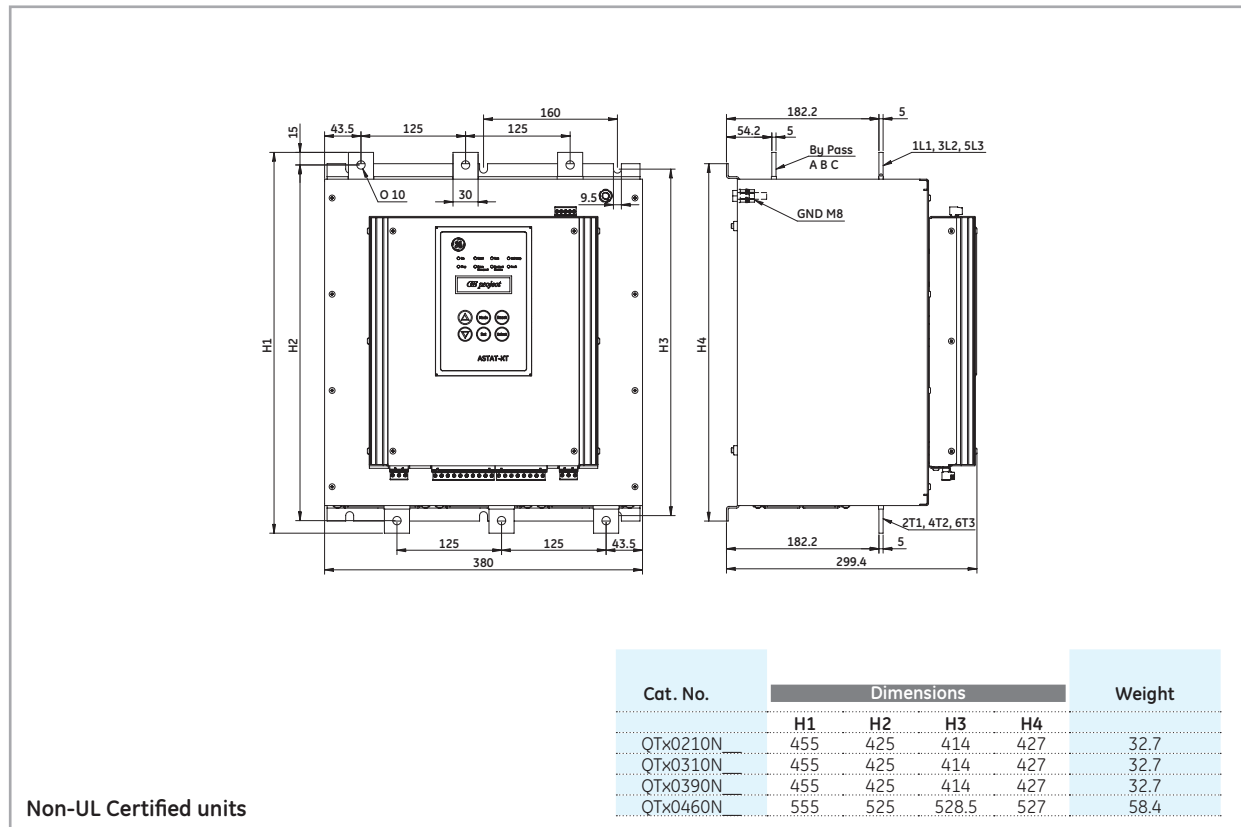

Non-UL Certified units

Digital soft starters

Intro

A

B

C

D

E

F

G

H

I

J/X





Dimensions and weights

Cat. No.: QTx0580N\_

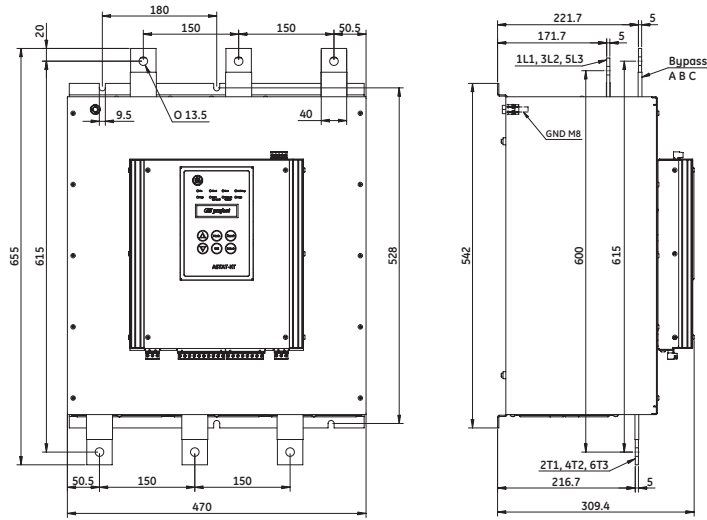

Non-UL Certified unit

Cat. No.	Weight
QTx0580U_	63.2

Cat. No.: QTx0650N\_

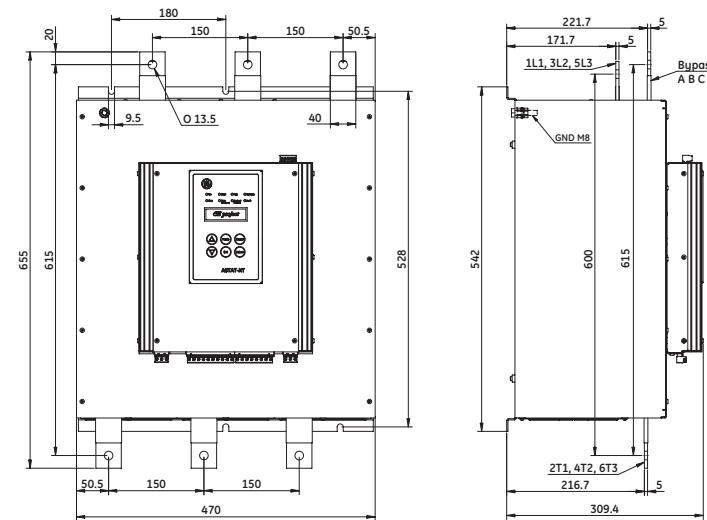

Non-UL Certified units

Cat. No.	Weight
QTx0650N_	64.8

Soft starters

Intro

A

B

C

D

E

F

G

H

I

J/X



Dimensions and weights

Cat. No.: QTx0950N\_

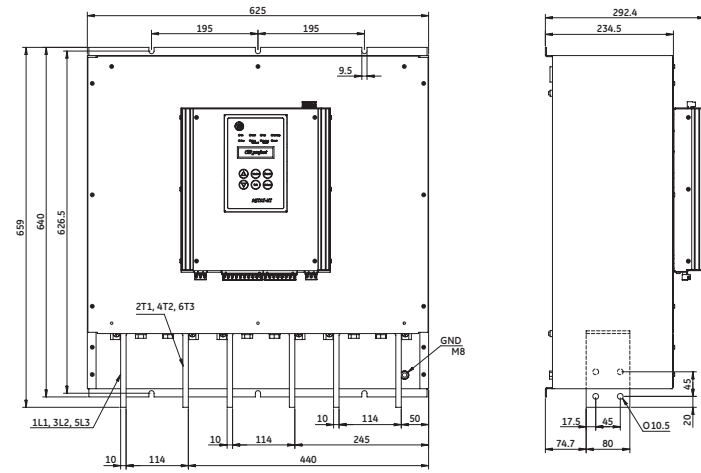

Remarks

1. This unit must be operated with a bypass contactor
  2. Add space for current transformers (supplied separately from the main unit) and bus bars for preparation for bypass
- Approximate current transformers dimensions: W=240mm, H=130mm, D=90mm

Non-UL Certified unit

Cat. No.	Weight
QTx0950N_	86.7

Cat. No.: QTx1100N\_ , QTx1400N

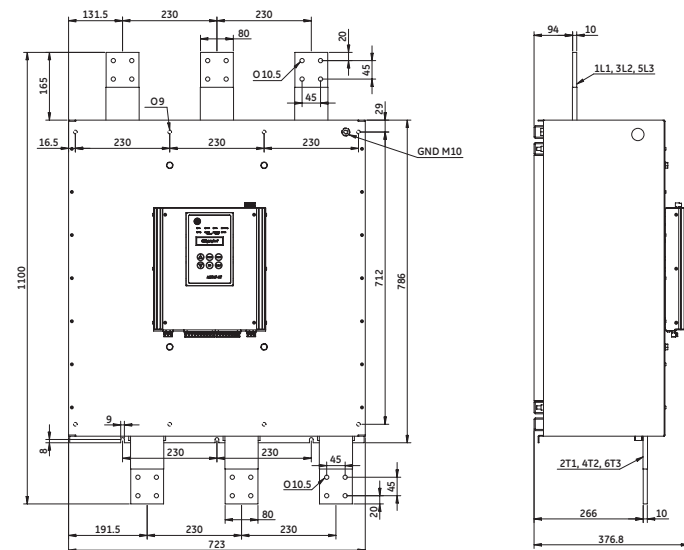

Remarks

1. Units must be operated with a bypass contactor
  2. Add space for current transformers (Supplied separately from main unit) and bus bars for preparation for bypass
- Approximate current transformers dimensions:  
 W=240mm, H=130mm, D=90mm. (for 1100A unit, Cat Numbers QTx1100N\_  
 W=270mm, H=155mm, D=90mm. (for 1400A unit, Cat Numbers QTx1400N\_

Non-UL Certified unit

Cat. No.	Weight
QTx1100N_	169.8
QTx1400N_	175.5

Digital soft starters

Intro

A

B

C

D

E

F

G

H

I

J/X



Dimensions and weights

Cat. No.: QTx0210U\_, QTx0315U\_, QTx0390U\_

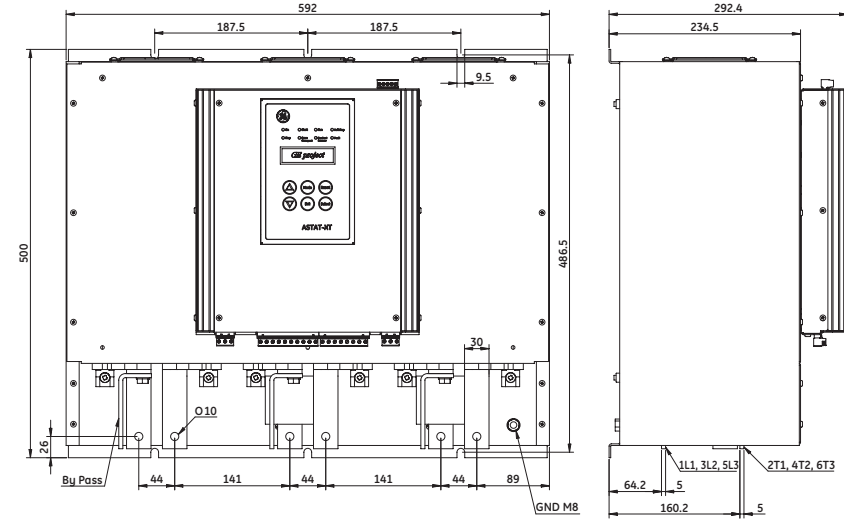

UL Certified unit

Cat. No.	Weight
QTx0210U_	32.7
QTx0315U_	32.7
QTx0390U_	32.7

Cat. No.: QTx0460U\_

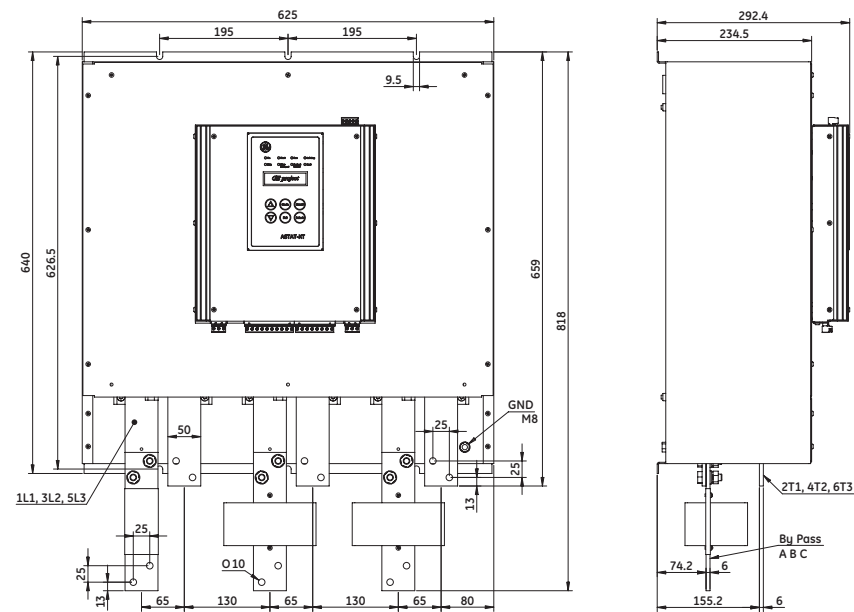

UL Certified unit

Cat. No.	Weight
QTx0460U_	61.8

Dimensions and weights

Cat. No.: QTx0580U\_, QTx0820U\_

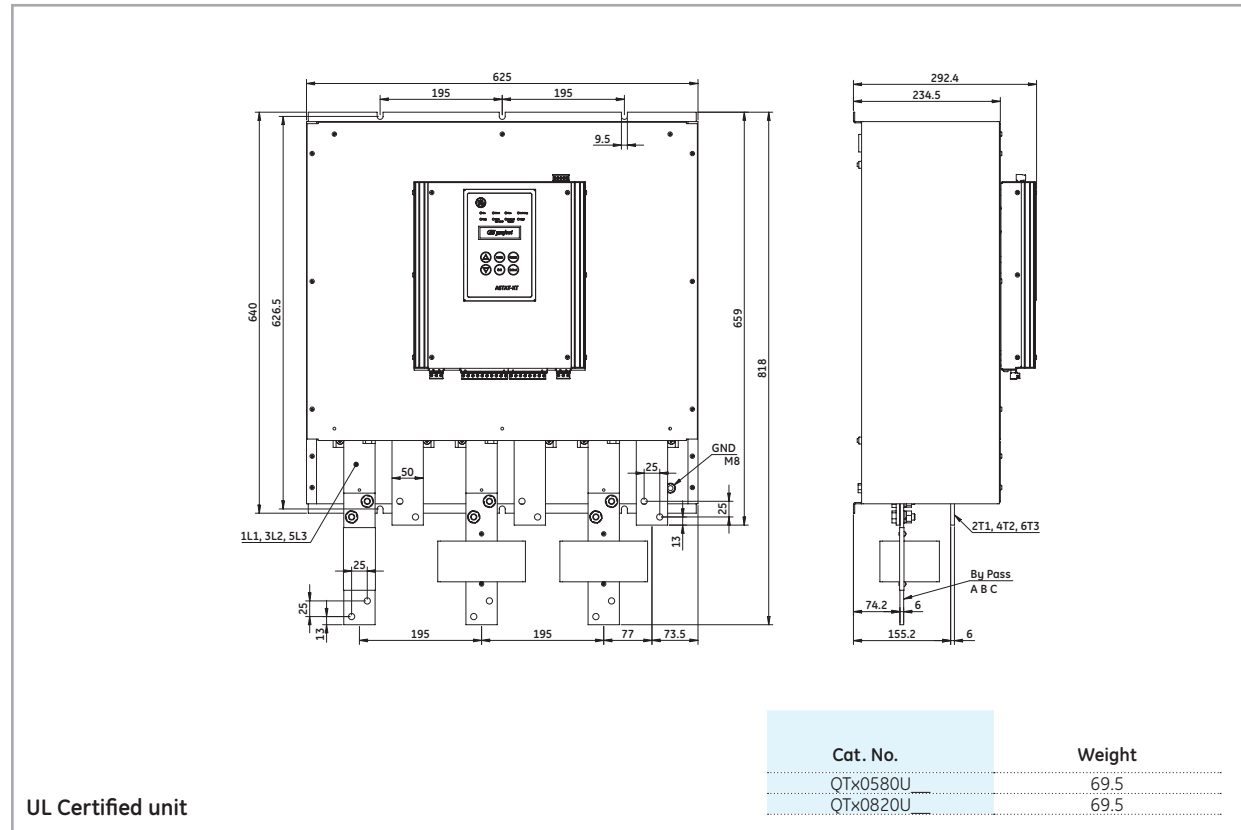

Digital soft starters

Intro

A

B

C

D

E

F

G

H

I

J/X



Notes

Grid of dotted lines for notes.

Soft starters

Intro

A

B

C

D

E

F

G

H

I

J/X





<b>GradiLux™ - Lighting dimmer-stabilizer</b>		Intro
J.3 Advantages		
J.4 Communication	<b>POWER DEVICES</b>	Contactors and overload relays
J.5 Selection guide		
J.6 Order codes		Auxiliary relays and contactors
J.8 Technical data		
J.9 Cross cable sections		Motor protection devices
J.10 Installation diagrams		
J.13 Dimensions		Applications
		Main switches
	<b>AUXILIARY DEVICES</b>	Control and signalling units
		Electronic relays and limit switches
	<b>POWER ELECTRONICS</b>	Speed drive units
		Soft starters
	<a href="#">Lighting dimmer-stabilizer/Numerical index</a>	<a href="#">J/X</a>



Notes

Grid of dotted lines for notes.

Lighting dimmer-stabilizer

Intro

A

B

C

D

E

F

G

H

I

J/X



## GradiLux™, reducing excessive power consumption

- ✔ Minimize lighting expenses
- ✔ Maximize efficiency of lighting
- ✔ Save up to 40% on energy bill
- ✔ Reduce carbon emissions
- ✔ Achieve fast payback



Harbour industry

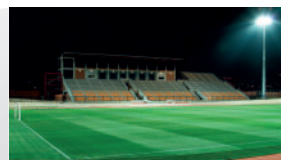

Sports arena



Tunnel



Airport

Railway station

Park

Car park

Fountain

Public lighting installations operate at approximately 4000 annual hours, accounting for a major part of the municipal energy bill. These lighting installations experience considerable voltage variations throughout the night, increasing power consumption and reducing lamp lifetime. Moreover, lighting levels are rarely adapted to vehicular traffic and pedestrians on public roads, even if the need to operate lighting at full power decreases considerably after midnight.

### Principle

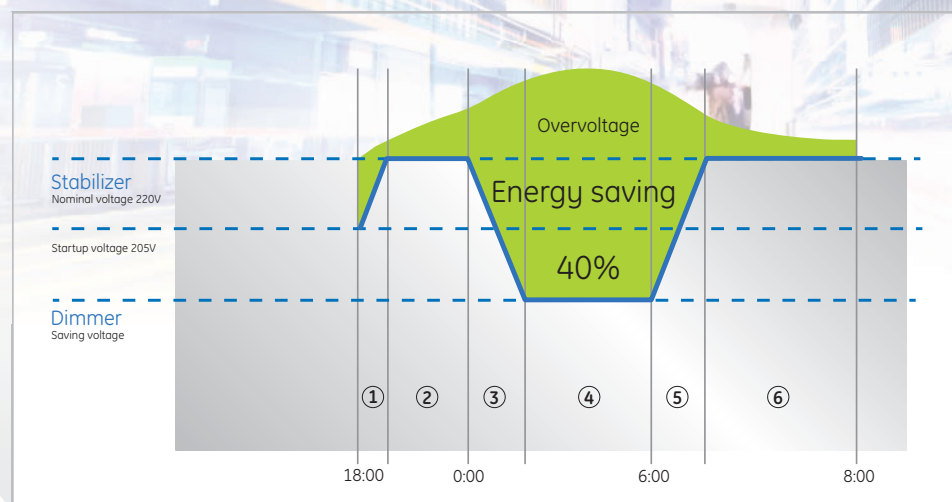

- ① **Progressive soft startup**, adapted to the warmup cycle of the lamps and avoiding initial overload.
- ② **Stabilization at nominal voltage**, with an accuracy of 1%, until the equipment initiates the saving mode of operation.
- ③ **Soft ramp down from nominal to saving voltage**. The maximum ramp speed is 6V per minute.
- ④ **Stabilization at saving voltage**, with an accuracy of 1%. The type of lamp determines the minimum saving voltage.
- ⑤ **Soft ramp up from saving to nominal voltage**. The maximum ramp speed is 6V per minute.
- ⑥ **Stabilization at nominal voltage**, with an accuracy of 1%, until the equipment is turned off.

Advantages

Intro

B

B

C

D

E

F

G

H

I

J/X



New



**Communication - Remote control**

*Dashboard*

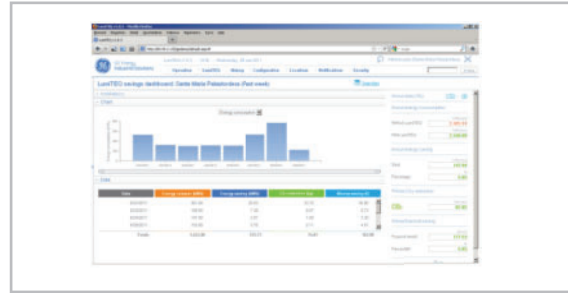

- Summary based on different data
- Reports about GradiLux community (different installations and cities)
- Visualise each GradiLux on detailed map or inside device tree
- Wide range of analysis options (daily/monthly/annual graphs, energy and CO<sub>2</sub> savings...)

*Safety*



- Secured webservice
- Control in safe environment via VPN
- Configuration of GradiLux community, define other users with monitoring and control access

*Savings*

- Reduce maintenance costs by receiving alarms notifications
- Allows quick diagnostic on real time data from each GradiLux with status and measurement information

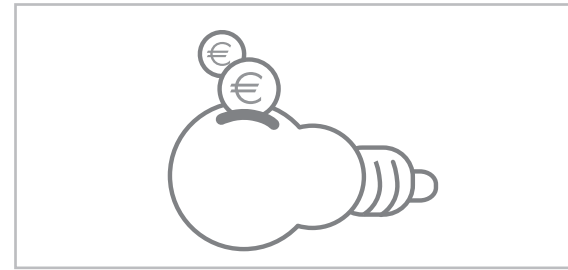

GradiLux



Secured VPN GPRS connection

End user



HTTPS Web browsing

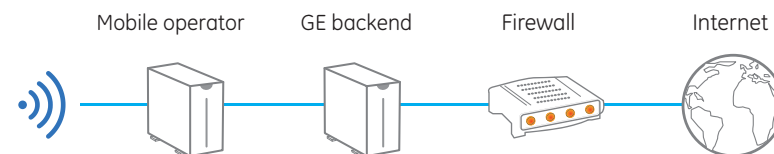

**Selection guide**

*On communication*

**1. Display version**

Controller with display for local configuration and control.

- Display: local control and configuration.
- Including calendar and timer scheduling an astronomical clock and alarm log.
- Access to input and output voltages, active and apparent power, power factor, load and savings measurements.
- Communications port: RS232 with RJ45 connector for local MODBUS communication.

**2. Web version**

Includes additional communication features for remote configuration and control.

- ComiTEQ card or box: communication device, providing an Ethernet communication interface supporting TCP/IP & SNMP protocols for remote access from the web portal.
- Optional GPRS modem: communication device for wireless remote access from the web portal.
- Data logger function with 6000 data values, programmable from 1 second to 1 hour.
- Alarm log for 200 events.

**3. I/O version**

Includes additional digital communication features for local configuration and control.

- 5 digital inputs and 5 relay outputs
- RS232 and RS485 communication port for local MODBUS communication
- 2 analogue ports



*On implementation*

**1. Stand-alone unit**

Three modules mounted on a vertical or horizontal frame for fast and easy installation.



**2. Modular unit**

One or three modules with fixing and interconnection kit for user specific installation.



Selection guide

Intro

B

B

C

D

E

F

G

H

I

J/X



New

Order codes

Stand-alone units



	Power (kVA)	HORIZONTAL				VERTICAL			
		Without manual bypass		With manual bypass		Without manual bypass		With manual bypass	
		Cat. no.	Ref. no.	Cat. no.	Ref. no.	Cat. no.	Ref. no.	Cat. no.	Ref. no.
Standard	7.5	GLIX07HS	817718	GLIX07HS-B	817732	GLIX07VS	817711	GLIX07VS-B	817725
With communication card		GLIX07HCC	817818	GLIX07HCC-B	817832	GLIX07VCC	817811	GLIX07VCC-B	817825
With I/O card		GLIX07HIC	817218	GLIX07HIC-B	817232	GLIX07VIC	817211	GLIX07VIC-B	817225
With Com & I/O cards		GLIX07HCIC	817318	GLIX07HCIC-B	817332	GLIX07VCIC	817311	GLIX07VCIC-B	817325
Standard	10.5	GLIX10HS	817719	GLIX10HS-B	817733	GLIX10VS	817712	GLIX10VS-B	817726
With communication card		GLIX10HCC	817819	GLIX10HCC-B	817833	GLIX10VCC	817812	GLIX10VCC-B	817826
With I/O card		GLIX10HIC	817219	GLIX10HIC-B	817233	GLIX10VIC	817212	GLIX10VIC-B	817226
With Com & I/O cards		GLIX10HCIC	817319	GLIX10HCIC-B	817333	GLIX10VCIC	817312	GLIX10VCIC-B	817326
Standard	15	GLIX15HS	817720	GLIX15HS-B	817734	GLIX15VS	817713	GLIX15VS-B	817727
With communication card		GLIX15HCC	817820	GLIX15HCC-B	817834	GLIX15VCC	817813	GLIX15VCC-B	817827
With I/O card		GLIX15HIC	817220	GLIX15HIC-B	817234	GLIX15VIC	817213	GLIX15VIC-B	817227
With Com & I/O cards		GLIX15HCIC	817320	GLIX15HCIC-B	817334	GLIX15VCIC	817313	GLIX15VCIC-B	817327
Standard	20	GLIX20HS	817721	GLIX20HS-B	817735	GLIX20VS	817714	GLIX20VS-B	817728
With communication card		GLIX20HCC	817821	GLIX20HCC-B	817835	GLIX20VCC	817814	GLIX20VCC-B	817828
With I/O card		GLIX20HIC	817221	GLIX20HIC-B	817235	GLIX20VIC	817214	GLIX20VIC-B	817228
With Com & I/O cards		GLIX20HCIC	817321	GLIX20HCIC-B	817335	GLIX20VCIC	817314	GLIX20VCIC-B	817328
Standard	25	GLIX25HS	817722	GLIX25HS-B	817736	GLIX25VS	817715	GLIX25VS-B	817729
With communication card		GLIX25HCC	817822	GLIX25HCC-B	817836	GLIX25VCC	817815	GLIX25VCC-B	817829
With I/O card		GLIX25HIC	817222	GLIX25HIC-B	817236	GLIX25VIC	817215	GLIX25VIC-B	817229
With Com & I/O cards		GLIX25HCIC	817322	GLIX25HCIC-B	817336	GLIX25VCIC	817315	GLIX25VCIC-B	817329
Standard	30	GLIX30HS	817723	GLIX30HS-B	817737	GLIX30VS	817716	GLIX30VS-B	817730
With communication card		GLIX30HCC	817823	GLIX30HCC-B	817837	GLIX30VCC	817816	GLIX30VCC-B	817830
With I/O card		GLIX30HIC	817223	GLIX30HIC-B	817237	GLIX30VIC	817216	GLIX30VIC-B	817230
With Com & I/O cards		GLIX30HCIC	817323	GLIX30HCIC-B	817337	GLIX30VCIC	817316	GLIX30VCIC-B	817330
Standard	45	GLIX45HS	817724	GLIX45HS-B	817738	GLIX45VS	817717	GLIX45VS-B	817731
With communication card		GLIX45HCC	817824	GLIX45HCC-B	817838	GLIX45VCC	817817	GLIX45VCC-B	817831
With I/O card		GLIX45HIC	817224	GLIX45HIC-B	817238	GLIX45VIC	817217	GLIX45VIC-B	817231
With Com & I/O cards		GLIX45HCIC	817324	GLIX45HCIC-B	817338	GLIX45VCIC	817317	GLIX45VCIC-B	817331

Lighting dimmer-stabilizer

Intro

A

B

C

D

E

F

G

H

I

J/X



Modular units

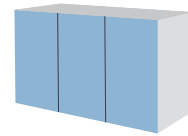

Power (kVA)	SINGLE PHASE	
	Without manual bypass	
	Cat. no.	Ref. no.
3.5	GLIN03KS	817700
6.7	GLIN06KS	817701
10	GLIN10KS	817702
15	GLIN15KS	817703

Power (kVA)	THREE PHASE	
	Without manual bypass	
	Cat. no.	Ref. no.
7.5	GLIX07KS	817704
10.5	GLIX10KS	817705
15	GLIX15KS	817706
20	GLIX20KS	817707
25	GLIX25KS	817708
30	GLIX30KS	817709
45	GLIX45KS	817710

Options



Description	Power (kVA)	Input	Cat. No.	Ref. No.
ComiTEQ box	3.5 - 45kVA	Single and three phase	GLCB	817801
I/O digital box	3.5 - 45kVA	Single and three phase	GLIOB	817803
Modem GSM/GPRS	3.5 - 45kVA	Single and three phase	GLCMDM	817806
Demonstration case	3.5 kVA	Single phase/ 230Vac	GLCMDM	817000

Order codes

Intro

B

B

C

D

E

F

G

H

I

J/X



New

Technical data

TECHNOLOGY INPUT	<b>Voltage</b>	Bidirectional "Buck" IGBT converter, electronic, static without transformer Single phase: 230V / Three phase: 3 x 400V
	<b>Regulation range</b>	+25% / -7% nominal voltage +25% / -17% reduced voltage HPSV (High Pressure Sodium Vapor) +25% / -10% reduced voltage MV (Mercury Vapor)
	<b>Frequency</b>	48 - 65 Hz
	<b>Module protection</b>	Input and output fuses and varistors for fault and surge protection
	<b>Protection per phase of equipment</b>	Disconnecter
OUTPUT	<b>Voltage</b>	Configurable from 215V to 230V (standard 220V)
	<b>Regulation accuracy</b>	Better than ±1% for input voltage range 230V +20% -3% Better than ±2.5% ±2V for input voltage range 230V -3% -7%
	<b>Soft start voltage</b>	Preset at 205V and configurable
	<b>Saving level</b>	Configurable from 180V to 210V
	<b>Transition speed setting</b>	From 1 to 6V/min
	<b>Response time</b>	< 40ms
	<b>Regulation</b>	Linear and independent for each phase
	<b>Efficiency</b>	> 96%
	<b>Imbalance between phases</b>	100% permissible
	<b>Reduced voltage adjustment</b>	Using LCD panel or RS232 communication
	<b>Permissible surge</b>	Nominally 110%, 120% & 150% (duration limits apply)
BYPASS	<b>Type</b>	Without zero crossing
	<b>Features</b>	Automatic, reversible, independent of each phase, independent operation, input for manual activation
	<b>Activation criteria</b>	Overheating, surge, fault, output fault, manual activation
	<b>Reactivation</b>	Automatic due to alarm cancellation. Number of retries: 5 - Time between retries: 2 minutes
COMMUNICATION	<b>Ports</b>	RS232 and RS485
	<b>Remote monitoring</b>	ComiTEQ TCP/IP communication card required
GENERAL	<b>Operating temperature</b>	-20°C up to +55°C (Derating applies at 4%/°C at 40°C or 45°C depending on the module power and working voltage)
	<b>Protection degree</b>	IP20 (not suitable for unprotected outdoor use)
	<b>Relative humidity</b>	Up to 95%, without condensation
	<b>Maximum altitude</b>	2000m
	<b>Mean time between failures (MTBF)</b>	24000 hours (5kVA & 6.7kVA) 21682 hours (10kVA & 15kVA)
	<b>Noise level at 1 metre</b>	<48dBA (with typical load)
FORMATS	<b>Stand-alone unit</b>	Modules assembled on a mounting base (chassis made of col-rolled carbon steel) with drill holes for fixing to wall
	<b>Modular kit</b>	3 modules + fixing supports + controls interconnection kit
STANDARD	<b>Safety</b>	EA0032:2007
	<b>Electromagnetic compatibility (EMC)</b>	IEC 62041:2003
OPTIONS	<b>Surge arrester</b>	Protection against destructive overvoltage surges
	<b>Manual bypass</b>	Interrupts the regulator for maintenance without switching off the light
	<b>GPRS modem</b>	Communication module for access to web portal
	<b>ComiTEQ communication card or box</b>	Module enabling TCP/IP communication for internet access
	<b>Digital I/O card or box</b>	General purpose digital I/O

Note: GradiLux cannot work with LED and lamps equipped with electronic ballast

## Recommended cross cable sections

Recommended protections, cross cable sections and connection terminals, for single phase mains of 220/230/240 V or three phase of 3x380/3x400/3x415 V at maximum power (100% load)

### Single phase formats

Description	Characteristics	GLIN03KS	GLIN06KS	GLIN10KS	GLIN15KS
Input earth leakage breaker	Sensitivity of 300mA; type A	16 A	32 A	50 A	80 A
Input circuit breaker	2 poles K charact.	16 A	32 A	50 A	80 A
Headline contactor	2 poles (AC1/AC3) 400 V - coil 230 V ac	16 A	32 A	50 A	80 A
Minimum cross cable section of input mains	RZ1-K	4 mm <sup>2</sup>	10 mm <sup>2</sup>	16 mm <sup>2</sup>	25 mm <sup>2</sup>
Maximum cross cable section of input mains	RZ1-K	35 mm <sup>2</sup>	35 mm <sup>2</sup>	35 mm <sup>2</sup>	70 mm <sup>2</sup>
Terminals for input cables	Ring terminal DIN 46234	D 6-4 to D 6-35	D 6-10 to D 6-35	D 6-16 to D 6-35	D 8-25 to D 8-70
	For screw	M6	M6	M6	M8
Minimum cross cable section of output mains	RZ1-K	4 mm <sup>2</sup>	10 mm <sup>2</sup>	16 mm <sup>2</sup>	25 mm <sup>2</sup>
Maximum cross cable section of output mains	RZ1-K	35 mm <sup>2</sup>	35 mm <sup>2</sup>	35 mm <sup>2</sup>	70 mm <sup>2</sup>
Terminals for output cables	Ring terminal DIN 46234	D 6-4 to D 6-35	D 6-10 to D 6-35	D 6-16 to D 6-35	D 8-25 to D 8-70
	For screw	M6	M6	M6	M8
Minimum cross cable section of control line	RZ1-K	2.5 mm <sup>2</sup>	2.5 mm <sup>2</sup>	2.5 mm <sup>2</sup>	2.5 mm <sup>2</sup>

### Three phase formats

Description	Characteristics	GLIX07KS	GLIX10KS	GLIX15KS	GLIX20KS	GLIX25KS	GLIX30KS	GLIX45KS
Input earth leakage breaker	Sensitivity of 300mA; type A	16 A	16 A	25 A	32 A	40 A	50 A	80 A
Input circuit breaker	2 poles K charact.	16 A	16 A	25 A	32 A	40 A	50 A	80 A
Headline contactor	2 poles (AC1/AC3) 400 V - coil 230 V ac	16 A	16 A	25 A	32 A	40 A	50 A	80 A
Minimum cross cable section of input mains	RZ1-K	4 mm <sup>2</sup>	4 mm <sup>2</sup>	6 mm <sup>2</sup>	10 mm <sup>2</sup>	10 mm <sup>2</sup>	16 mm <sup>2</sup>	25 mm <sup>2</sup>
Maximum cross cable section of input mains	RZ1-K	35 mm <sup>2</sup>	35 mm <sup>2</sup>	35 mm <sup>2</sup>	35 mm <sup>2</sup>	35 mm <sup>2</sup>	35 mm <sup>2</sup>	70 mm <sup>2</sup>
Terminals for input cables	Ring terminal DIN 46234	D 6-4 to D 6-35	D 6-4 to D 6-35	D 6-6 to D 6-35	D 6-10 to D 6-35	D 6-10 to D 6-35	D 6-16 to D 6-35	D 8-25 to D 8-70
	For screw	M6	M6	M6	M6	M6	M6	M8
Minimum cross cable section of output mains	RZ1-K	4 mm <sup>2</sup>	4 mm <sup>2</sup>	6 mm <sup>2</sup>	10 mm <sup>2</sup>	10 mm <sup>2</sup>	16 mm <sup>2</sup>	25 mm <sup>2</sup>
Maximum cross cable section of output mains	RZ1-K	35 mm <sup>2</sup>	35 mm <sup>2</sup>	35 mm <sup>2</sup>	35 mm <sup>2</sup>	35 mm <sup>2</sup>	35 mm <sup>2</sup>	70 mm <sup>2</sup>
Terminals for output cables	Ring terminal DIN 46234	D 6-4 to D 6-35	D 6-4 to D 6-35	D 6-6 to D 6-35	D 6-10 to D 6-35	D 6-10 to D 6-35	D 6-16 to D 6-35	D 8-25 to D 8-70
	For screw	M6	M6	M6	M6	M6	M6	M8
Minimum cross cable section of control line	RZ1-K	2.5 mm <sup>2</sup>	2.5 mm <sup>2</sup>	2.5 mm <sup>2</sup>	2.5 mm <sup>2</sup>	2.5 mm <sup>2</sup>	2.5 mm <sup>2</sup>	2.5 mm <sup>2</sup>

Specifications

Intro

B

B

C

D

E

F

G

H

I

J/X



New

Installation diagrams

Installation diagram for single phase format (M)

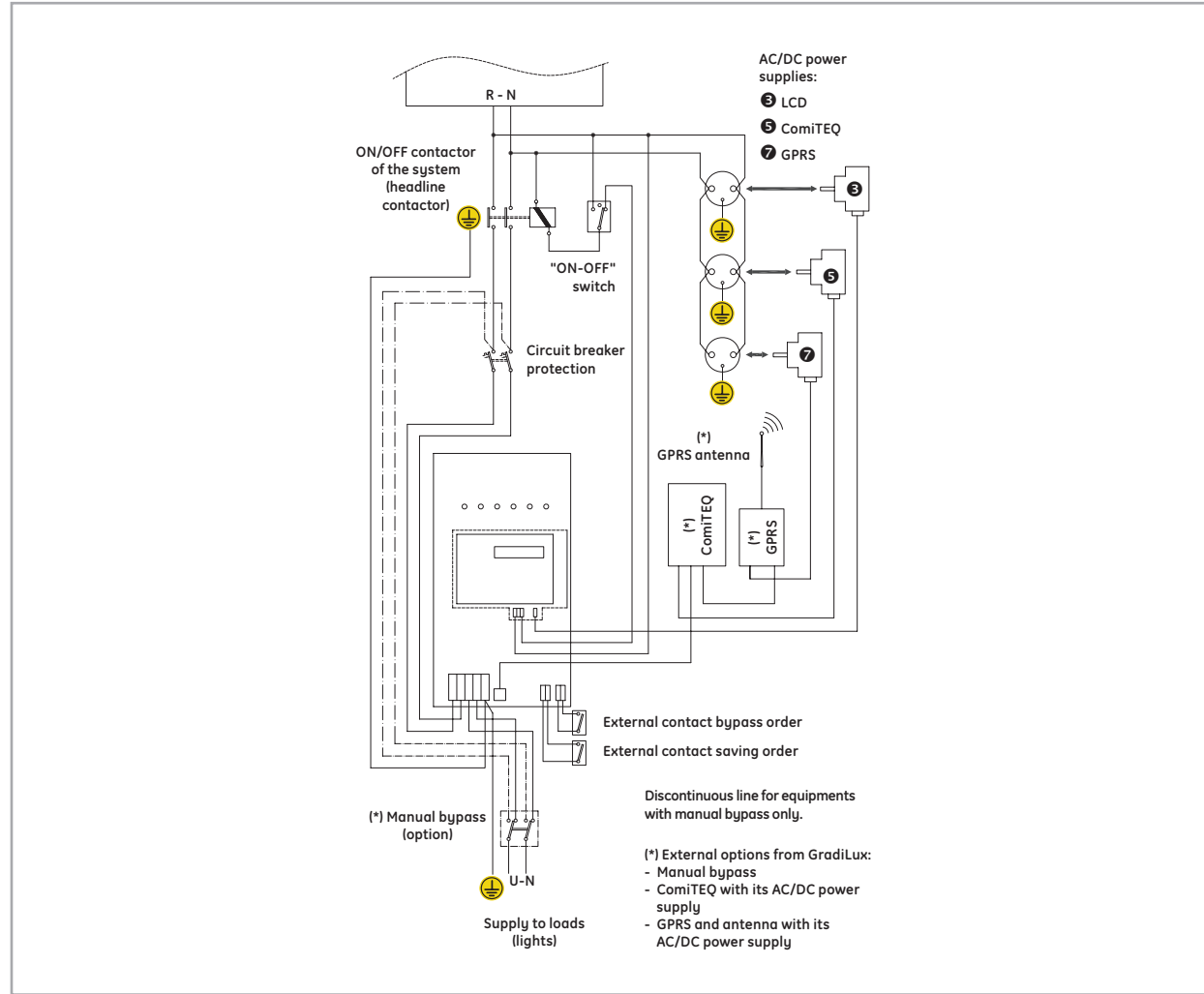

Installation diagrams

Installation diagram for three phase format (M)

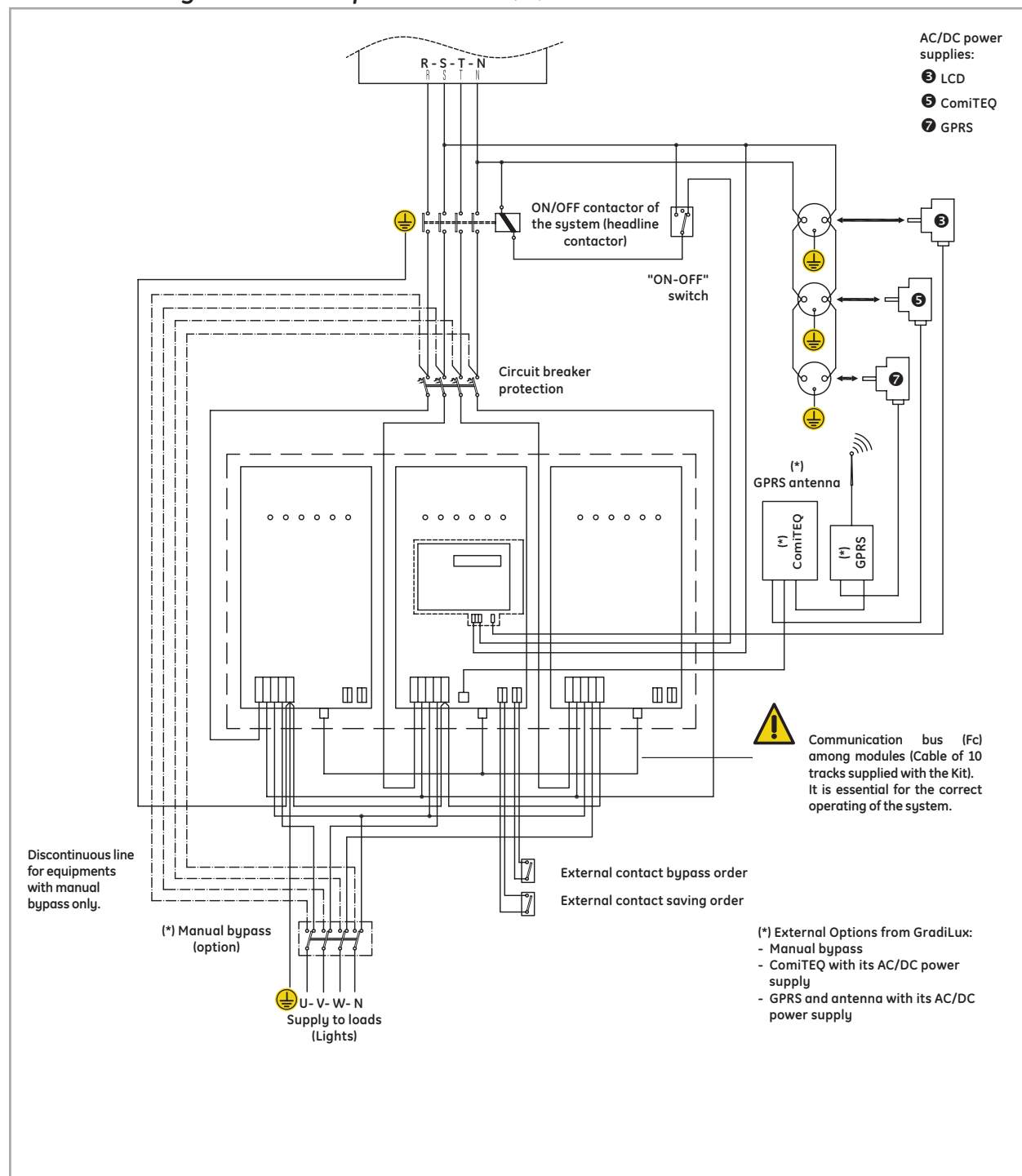

Installation diagrams

Intro

B

B

C

D

E

F

G

H

I

J/X



New



Installation diagrams

Installation diagram for three phase formats (H) or (V)

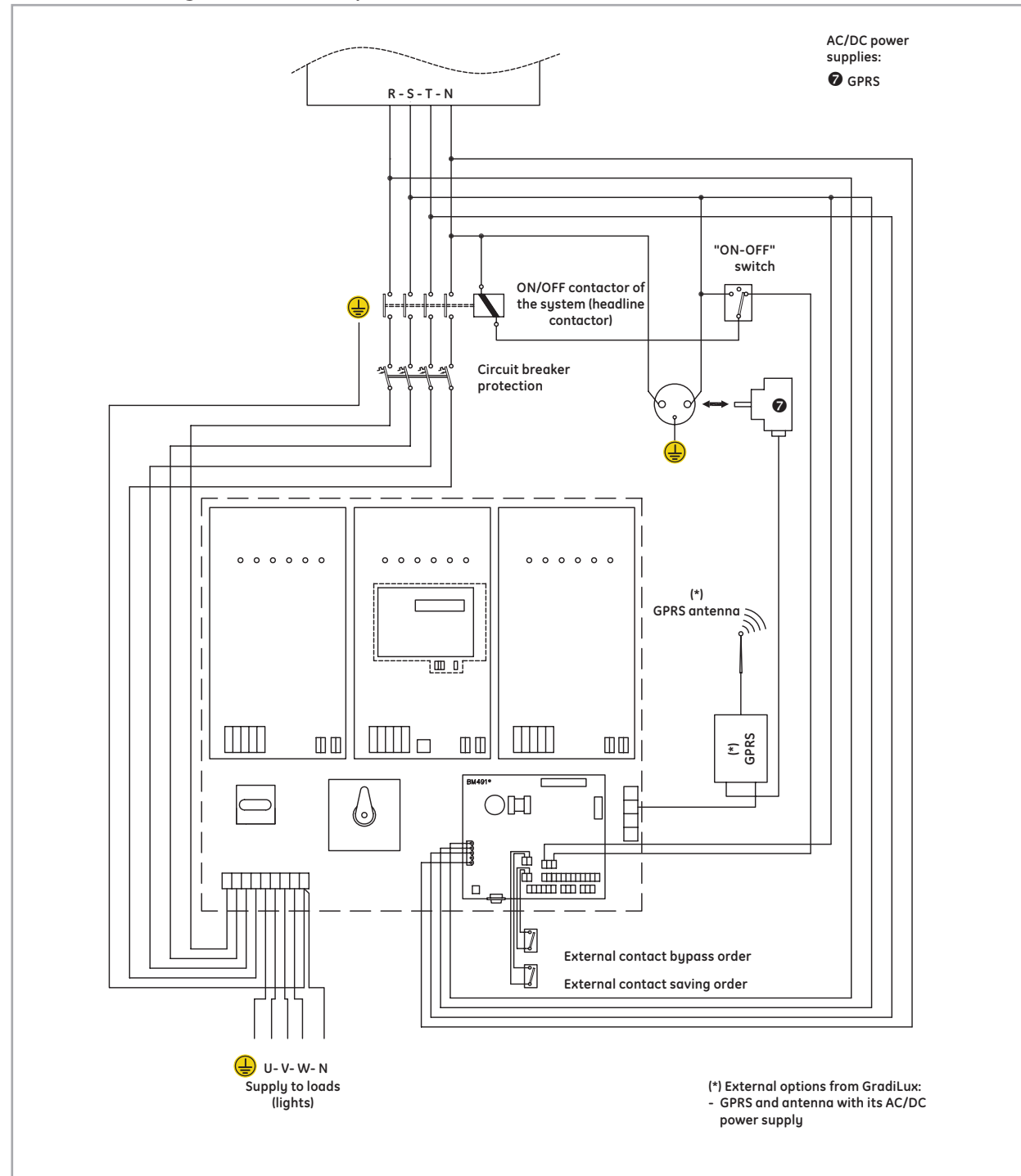

Lighting dimmer-stabilizer

Intro

A

B

C

D

E

F

G

H

I

J/X



New

Dimensions

Stand-alone unit - Horizontal

Power (kVa)	Dimensions (mm) (H x W x D)	Weight (kg)
7.5	610 x 520 x 231+35	35
10		35
15		35
20		38
25	770 x 520 x 231+35	50
30		50
45		53

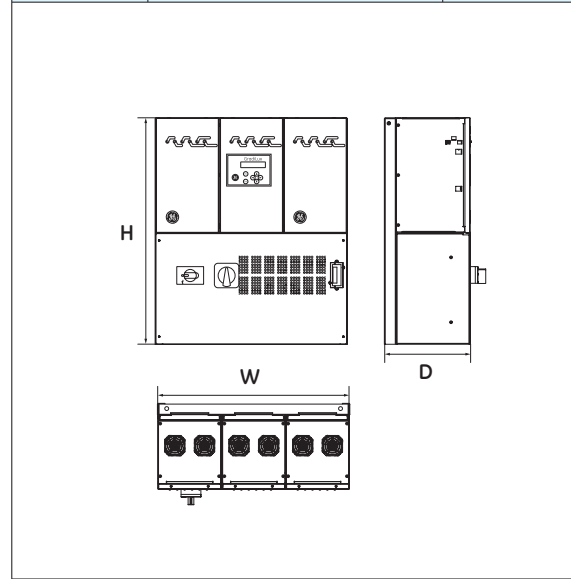

Stand-alone unit - Vertical

Power (kVa)	Dimensions (mm) (H x W x D)	Weight (kg)
7.5	823 x 350 x 245	35
10		35
15		35
20		38
25	1142 x 350 x 245	50
30		50
45		53

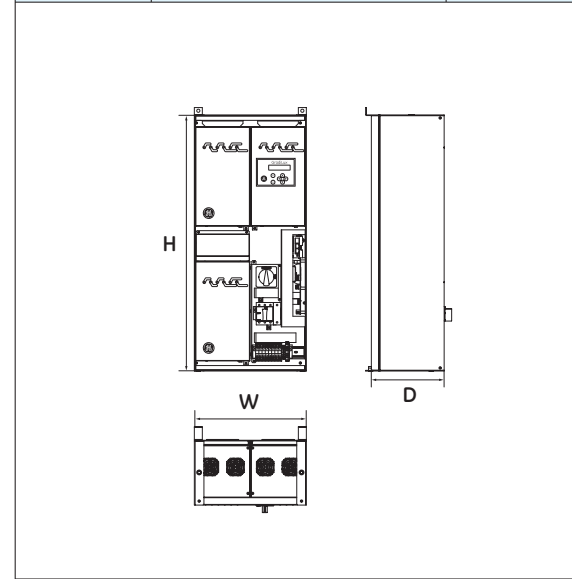

Modular unit - Single phase

Power (kVa)	Dimensions (mm) (H x W x D)	Weight (kg)
3.5	346 x 172 x 200	8
6.7		9
10	470 x 172 x 200	13
15		14

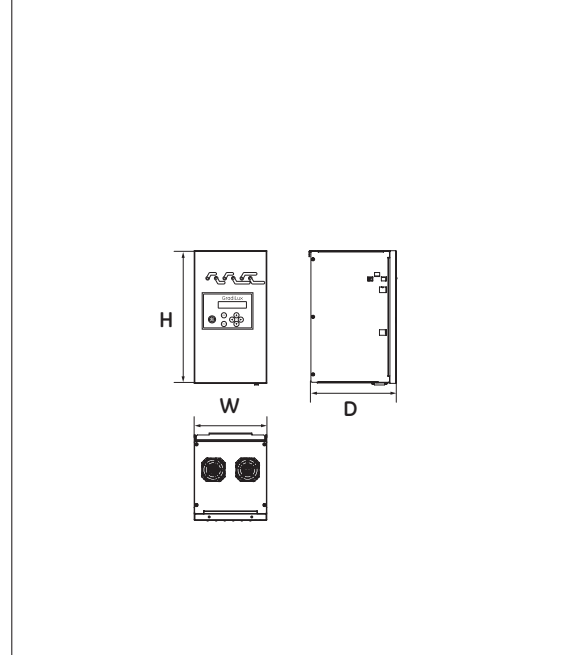

Modular unit - Three phase

Power (kVa)	Dimensions (mm) (H x W x D)	Weight (kg)
7.5	346 x 516 x 2400	24
10		24
15		24
20		27
25	470 x 516 x 200	39
30		39
45		42

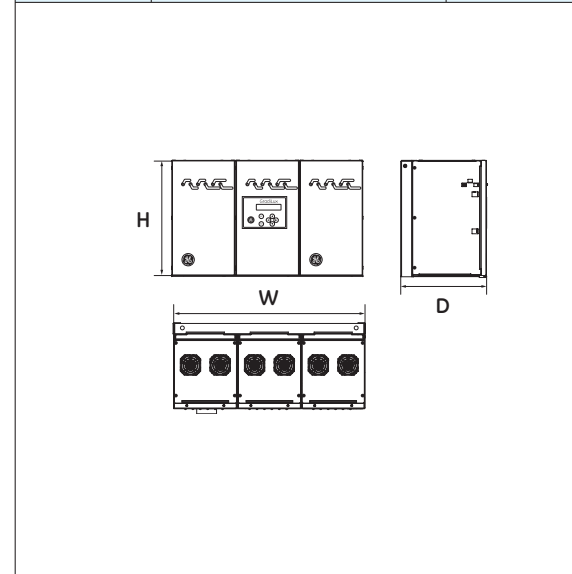

Dimensions

Intro

B

B

C

D

E

F

G

H

I

J/X



New

Notes

Grid of dotted lines for notes.

Lighting dimmer-stabilizer

Intro

A

B

C

D

E

F

G

H

I

J/X





			Intro
	<b>POWER DEVICES</b>	Contactors and overload relays	B
		Auxiliary relays and contactors	B
		Motor protection devices	C
X.2	<b>Completed catalogue numbers</b>	Applications	D
X.2	Chap. A - Series M - Contactors	Main switches	E
X.4	Chap. A - Series CL - Contactors		
X.5	Chap. A - Series CK - Contactors		
X.6	Chap. B - Series M - Auxiliary contactors	<b>AUXILIARY DEVICES</b> Control and signalling units	F
X.7	Chap. B - Series RL - Auxiliary contactors		
X.8	Chap. F - Series P9 - Control and signalling units Ø 22 mm	Electronic relays and limit switches	G
X.8	Chap. F - Series 077 - Control and signalling units Ø 30 mm		
	<b>POWER ELECTRONICS</b>	Speed drive units	H
X.9	<b>General index by catalogue number</b>	Soft starters	I
X.20	<b>General index by reference number</b>	Lighting dimmer-stabilizer/Numerical index	J/X



This list shows the catalogue and reference numbers for the **miniconductors** with the most usual voltages. For other voltages/types, please consult us.

Cat. no.	Ref. no.	Cat. no.	Ref. no.	Cat. no.	Ref. no.	Cat. no.	Ref. no.
MC1A310ATG	100212 48V	MC1A301AFY	102679 600V	MC0A400AT5	102801 220V	MC1AA00AT7	103034 240V
MC1A310ATK	102610 115/127V	MC1A301AIM	102716 208/220V	MC0A400AT6	102802 230V	MC1AA00AT8	103035 440V
MC1A310ATN	100214 220/240V	MC1A301AIU	100265 440V	MC0A400AT7	102803 240V	MC1AB00AF1	103070 24V
MC1A310ATS	102613 260V	MC1A301IARU	103404 440V	MC0A400AT8	102804 440V	MC1AB00AF2	103071 42V
MC1A310ATW	100215 380/400V	MC1A301ATE	102628 32V	MC0A400AT9	100290 48V	MC1AB00AF3	103072 110/115V
MC1A400AFG	100392 48V	MC1A301ATM	102632 208/220V	MC0A400AT1	102839 24V	MC1AB00AF4	103073 120V
MC1A400AFK	103042 115/127V	MC1A301ATU	100225 440V	MC0A400AT2	102840 42V	MC1AB00AF5	103074 220V
MC1A400AFN	100394 220/240V	MC1A301ATY	102637 600V	MC0A400AT3	102841 110/115V	MC1AB00AF6	103075 230V
MC1A400AFS	103045 260V	MC1A310AFE	102649 32V	MC0A400AT4	102842 120V	MC1AB00AF7	103076 240V
MC1A400AFU	100395 380/400V	MC1A310AFM	102653 208/220V	MC0A400AT5	102843 220V	MC1AB00AF8	103077 440V
MC1A400AFV	103047 415/440V	MC1A310AFU	100235 440V	MC0A400AT6	102844 230V	MC1AB00A19	100427 48V
MC1A400AIG	100422 48V	MC1A310AFY	102658 600V	MC0A400AT7	102845 240V	MC1AB00AT1	103007 24V
MC1A400AIN	100424 220/240V	MC1A310AIU	100255 440V	MC0A400AT8	102846 440V	MC1AB00AT2	103008 42V
MC1A400AIU	100425 380/400V	MC1A310ARU	103391 440V	MC0A400AT9	102847 440V	MC1AB00AT3	103009 110/115V
MC1A400AIW	103110 415/440V	MC1A310ATE	102607 32V	MC0A400AT1	102819 42V	MC1AB00AT4	103010 120V
MC1A400ATG	100362 48V	MC1A310ATM	102611 208/220V	MC0A400AT2	102820 110/115V	MC1AB00AT5	103011 220V
MC1A400ATK	102979 115/127V	MC1A310ATU	100215 440V	MC0A400AT3	102821 120V	MC1AB00AT6	103012 230V
MC1A400ATN	100364 220/240V	MC1A310ATY	102616 600V	MC0A400AT4	102822 220V	MC1AB00AT7	103013 240V
MC1A400ATS	102982 260V	MC1A400AFE	103039 32V	MC0A400AT5	102823 230V	MC1AB00AT8	103014 440V
MC1A400ATU	100365 380/400V	MC1A400AFM	103043 208/220V	MC0A400AT6	102824 240V	MC1AB00AT9	100400 48V
MC1A400ATW	102984 415/440V	MC1A400AFU	100395 440V	MC0A400AT7	102825 440V	MC2A301A11	103273 24V
MC1A400AFV	100412 48V	MC1A400AFY	103048 600V	MC1A301AF1	102680 24V	MC2A301A19	103272 48V
MC1A400AFG	100412 48V	MC1A400A1U	113267 600V	MC1A301AF2	102681 42V	MC2A301AR1	103425 24V
MC1A400AFK	103084 115/127V	MC1A400ATE	102976 32V	MC1A301AF3	102682 110/115V	MC2A301AR9	103426 48V
MC1A400AFN	100414 220/240V	MC1A400ATM	102980 208/220V	MC1A301AF4	102683 120V	MC2A301AT1	103569 24V
MC1A400AFS	103087 260V	MC1A400ATU	100365 440V	MC1A301AF5	102684 220V	MC2A301AT3	103358 110/115V
MC1A400AFU	100415 380/400V	MC1A400ATY	102985 600V	MC1A301AF6	102685 230V	MC2A301AT5	103570 220V
MC1A400AFV	103089 415/440V	MC1A400AFE	103081 32V	MC1A301AF7	102686 240V	MC2A301AT6	103571 230V
MC1A400AIG	100444 220/240V	MC1A400AFM	103085 208/220V	MC1A301AF8	102687 440V	MC2A310A11	103271 24V
MC1A400AIN	100382 48V	MC1A400AFU	100415 440V	MC1A301AF9	102688 240V	MC2A310A19	103270 48V
MC1A400AIU	103021 115/127V	MC1A400AFY	103090 600V	MC1A301AI1	102722 24V	MC2A310AR1	103412 24V
MC1A400ATG	100384 220/240V	MC1A400ATE	103018 32V	MC1A301AI5	102726 220V	MC2A310AR9	103413 48V
MC1A400ATK	103024 260V	MC1A400ATM	103022 208/220V	MC1A301AI6	107167 230V	MC2A310AT1	103577 24V
MC1A400ATS	103085 380/400V	MC1A400ATU	100385 440V	MC1A301AR1	103399 24V	MC2A310AT5	103578 220V
MC1A400ATU	103026 415/440V	MC1A400ATY	103027 600V	MC1A301AR9	103400 48V	MC2A310AT6	103579 230V
MC1A400ATW	100402 48V	MC1A800AFE	103060 32V	MC1A301AT1	102638 24V	MC2A400AT6	103595 230V
MC1A400AFV	103063 115/127V	MC1A800AFM	103064 208/220V	MC1A301AT2	102639 42V		
MC1A800AFN	100404 220/240V	MC1A800AFU	100405 440V	MC1A301AT3	102640 110/115V	Direct current	pg. A.45-A.47
MC1A800AFS	103066 260V	MC1A800AFY	103069 600V	MC1A301AT4	102641 120V	MBOCA	102415 6V
MC1A800AFU	100405 380/400V	MC1A800ATE	102997 32V	MC1A301AT5	102642 220V	MBOCB	100460 12V
MC1A800AFV	103068 415/440V	MC1A800ATM	103001 208/220V	MC1A301AT6	102643 230V	MBOCC	102416 32V
MC1A800AIG	100434 220/240V	MC1A800ATU	100375 440V	MC1A301AT7	102644 240V	MBOCD	100466 24V
MC1A800AIN	100372 48V	MC1A800ATY	103006 600V	MC1A301AT8	102645 440V	MBOCE	102417 36V
MC1A800AIU	103000 115/127V	MC2A301ARU	103430 440V	MC1A301AT9	100320 48V	MBOCF	102418 42V
MC1A800ATG	100374 220/240V	MC2A301ATU	103567 440V	MC1A310AF1	102659 24V	MBOCG	100467 48V
MC1A800ATK	103003 260V	MC2A310ARU	103417 440V	MC1A310AF2	102660 42V	MBOCH	102419 60V
MC1A800ATS	100375 380/400V	MC2A310ATU	103575 440V	MC1A310AF3	102661 110/115V	MBOCI	102420 72V
MC1A800ATU	103005 415/440V	MC2A400ATU	103292 440V	MC1A310AF4	102662 120V	MBOCJ	100468 110V
MC1A800ATW	101019 220/240V			MC1A310AF5	102663 220V	MBOCK	102421 120V
MC2A301AIU	103289 380/400V	50/60Hz	pg. A.45-A.47	MC1A310AF6	102664 230V	MBOCL	102422 125V
MC2A301ARN	103429 220/240V	MBOA1	102407 24V	MC1A310AF7	102665 240V	MBOCN	100469 220V
MC2A301ARU	103430 380/400V	MBOA2	102408 42V	MC1A310AF8	102666 440V	MBOCR	102423 240V
MC2A301ATG	103564 48V	MBOA3	102409 110/115V	MC1A310AI1	102701 24V	MBOCS	100449 250V
MC2A301ATN	103566 220/240V	MBOA4	102410 120V	MC1A310AI3	102703 110/115V	MCOC301AFD	100186 24V
MC2A301ATN	103567 380/400V	MBOA5	102411 220V	MC1A310AI5	102705 220V	MCOC301AID	100206 24V
MC2A310AIN	101018 220/240V	MBOA6	102412 230V	MC1A310AI9	102706 48V	MCOC301ARB	103379 12V
MC2A310AIU	103290 380/400V	MBOA7	102413 240V	MC1A310AR1	103386 24V	MCOC301ARD	103380 24V
MC2A310ARN	103416 220/240V	MBOA8	102414 440V	MC1A310AR9	103387 48V	MCOC301ARG	103381 48V
MC2A310ARU	103417 380/400V	MBOA9	133717 48V	MC1A310AT1	102617 24V	MCOC301ARH	103382 60V
MC2A310ATG	103572 48V	MC0A301AI1	102542 24V	MC1A310AT2	102618 42V	MCOC301ARJ	103383 110V
MC2A310ATN	103574 220/240V	MC0A301AI3	102544 110/115V	MC1A310AT3	102619 110/115V	MCOC301ARK	103384 120V
MC2A310ATU	103575 380/400V	MC0A301AI5	102546 220V	MC1A310AT4	102620 120V	MCOC301ARN	103385 220V
		MC0A301AI6	102547 230V	MC1A310AT5	102621 220V	MCOC301ATB	100160 12V
60Hz	pg. A.45-A.47	MC0A301AR1	103373 24V	MC1A310AT6	102622 230V	MCOC301ATD	100166 24V
MBOAE	102397 32V	MC0A301AR9	103374 48V	MC1A310AT7	102623 240V	MCOC301ATE	102561 36V
MBOAF	102398 48V	MC0A301AT1	102458 24V	MC1A310AT8	102624 440V	MCOC301ATF	102562 42V
MBOAM	102401 208/220V	MC0A301AT2	102459 42V	MC1A310AT9	100298 48V	MCOC301ATG	100167 48V
MBOAU	213532 440V	MC0A301AT3	102471 110/115V	MC1A400AF1	103049 24V	MCOC301ATH	102563 60V
MBOAV	102406 600V	MC0A301AT4	102461 120V	MC1A400AF2	103050 42V	MCOC301ATI	102564 72V
MC0A301AIU	100205 440V	MC0A301AT5	102462 220V	MC1A400AF3	103051 110/115V	MCOC301ATJ	100168 110V
MC0A301ARU	103378 440V	MC0A301AT6	102463 230V	MC1A400AF4	103052 120V	MCOC301ATK	102565 120V
MC0A301ATE	102448 32V	MC0A301AT7	102464 240V	MC1A400AF5	103053 220V	MCOC301ATN	100169 220V
MC0A301ATM	102452 208/220V	MC0A301AT8	102465 440V	MC1A400AF6	103054 230V	MCOC301ATR	102567 240V
MC0A301ATU	100165 440V	MC0A301AT9	100299 48V	MC1A400AF7	103055 240V	MCOC310AFB	100170 12V
MC0A301ATY	102457 600V	MC0A310AF1	102479 24V	MC1A400AF8	103056 440V	MCOC310AFD	100176 24V
MC0A310AIM	100147 208/220V	MC0A310AF5	102483 220V	MC1A400A11	103112 24V	MCOC310AFG	100258 48V
MC0A310AIG	100262 48V	MC0A310AI1	102521 24V	MC1A400AT1	102986 24V	MCOC310AID	100196 24V
MC0A310AIN	100264 220/240V	MC0A310AI3	102523 110/115V	MC1A400AT2	102987 42V	MCOC310AIG	100259 48V
MC0A310AIU	100265 380/400V	MC0A310AI5	102525 220V	MC1A400AT3	102988 110/115V	MCOC310AIJ	100198 110V
MC0A310ARN	103403 220/240V	MC0A310AI6	102526 230V	MC1A400AT4	102989 120V	MCOC310ARB	103366 12V
MC0A310ARU	103404 380/400V	MC0A310AI8	107492 440V	MC1A400AT5	102990 220V	MCOC310ARD	103367 24V
MC0A310ATG	100222 48V	MC0A310AT1	103360 24V	MC1A400AT6	102991 230V	MCOC310ARG	103368 48V
MC0A310ATK	102631 115/127V	MC0A400AIM	102917 208/220V	MC1A400AT7	102992 240V	MCOC310ARH	103369 60V
MC0A310ATN	100224 220/240V	MC0A400AIU	100335 440V	MC1A400AT8	102993 440V	MCOC310ARJ	103370 110V
MC0A310ATS	102634 260V	MC0A400ATE	102787 32V	MC1A400AT9	100296 48V	MCOC310ARK	103371 120V
MC0A310ATW	100225 380/400V	MC0A400ATM	102791 208/220V	MC1A400AF1	103091 24V	MCOC310ARN	103372 220V
MC1A301AFW	102636 415/440V	MC0A400ATU	100275 440V	MC1A400AF2	103092 42V	MCOC310ATB	100150 12V
MC1A310AFG	100232 48V	MC0A400ATY	102796 600V	MC1A400AF3	103093 110/115V	MCOC310ATC	102551 32V
MC1A310AFK	102652 115/127V	MC0A400ATE	102829 32V	MC1A400AF4	103094 120V	MCOC310ATD	100156 24V
MC1A310AFN	100234 220/240V	MC0A400ATM	102833 208/220V	MC1A400AF5	103095 220V	MCOC310ATE	102552 36V
MC							



Cat. no.	Ref. no.	Cat. no.	Ref. no.
MC0C400AFD	100306 24V	MC1CB00ATI	103230 72V
MC0C400AFG	100267 48V	MC1CB00ATJ	100378 110V
MC0C400AID	100336 24V	MC1CB00ATK	103231 120V
MC0C400AIH	103202 60V	MC1CB00ATN	100379 220V
MC0C400ATB	100270 12V	MC1CB00ATR	103233 240V
MC0C400ATD	100276 24V	MC1I301ARD	103441 24V
MC0C400ATE	103164 36V	MC1I301ATD	100573 24V
MC0C400ATF	103165 42V	MC1I301ARD	103440 24V
MC0C400ATG	100277 48V	MC1I301ATD	100572 24V
MC0C400ATH	103166 60V	MC2C301AIB	103287 12V
MC0C400ATI	103167 72V	MC2C301AID	103286 24V
MC0C400ATJ	100278 110V	MC2C301AIG	103285 48V
MC0C400ATK	103168 120V	MC2C301AIH	103284 60V
MC0C400ATL	103169 125V	MC2C301AIJ	103283 110V
MC0C400ATN	100279 220V	MC2C301AIK	103282 120V
MC0C400ATR	103170 240V	MC2C301AIN	103281 220V
MC0C800ATB	100280 12V	MC2C301ARB	103431 12V
MC0C800ATD	100286 24V	MC2C301ARD	103432 24V
MC0C800ATE	103173 36V	MC2C301ARG	103433 48V
MC0C800ATF	103174 42V	MC2C301ARH	103434 60V
MC0C800ATG	100287 48V	MC2C301ARJ	103435 110V
MC0C800ATH	103175 60V	MC2C301ARK	103436 120V
MC0C800ATI	103176 72V	MC2C301ARN	103437 220V
MC0C800ATJ	100288 110V	MC2C301ATB	103589 12V
MC0C800ATK	103177 120V	MC2C301ATD	103580 24V
MC0C800ATL	103178 125V	MC2C301ATG	103581 48V
MC0C800ATN	100289 220V	MC2C301ATJ	103582 110V
MC0C800ATR	103179 240V	MC2C301ATN	103583 220V
MC1C301AFD	100246 24V	MC2C301AIB	103280 12V
MC1C301AFJ	100248 110V	MC2C301AID	103279 24V
MC1C301AID	100266 24V	MC2C301AIG	103278 48V
MC1C301ARB	103405 12V	MC2C301AIH	103277 60V
MC1C301ARD	103406 24V	MC2C301AIJ	103276 110V
MC1C301ARG	103407 48V	MC2C301AIK	103275 120V
MC1C301ARH	103408 60V	MC2C301AIN	103274 220V
MC1C301ARJ	103409 110V	MC2C301ARB	103418 12V
MC1C301ARK	103410 120V	MC2C301ARD	103419 24V
MC1C301ARN	103411 220V	MC2C301ARG	103420 48V
MC1C301ATB	100220 12V	MC2C301ARH	103421 60V
MC1C301ATC	102740 32V	MC2C301ARJ	103422 110V
MC1C301ATD	100226 24V	MC2C301ARK	103423 120V
MC1C301ATE	102741 36V	MC2C301ARN	103424 220V
MC1C301ATF	102742 42V	MC2C301ATB	103588 12V
MC1C301ATG	100227 48V	MC2C301ATD	103584 24V
MC1C301ATH	102743 60V	MC2C301ATG	103585 48V
MC1C301ATI	102744 72V	MC2C301ATJ	103586 110V
MC1C301ATJ	100228 110V	MC2C301ATN	103587 220V
MC1C301ATK	102745 120V		
MC1C301ATL	102746 125V		
MC1C301ATN	100229 220V		
MC1C301ATR	102747 240V		
MC1C310AFB	100230 12V		
MC1C310AFD	100236 24V		
MC1C310AID	100256 24V		
MC1C310AIG	100257 48V		
MC1C310ARB	103392 12V		
MC1C310ARD	103393 24V		
MC1C310ARG	103394 48V		
MC1C310ARH	103395 60V		
MC1C310ARJ	103396 110V		
MC1C310ARK	103397 120V		
MC1C310ARN	103398 220V		
MC1C310ATB	100210 12V		
MC1C310ATD	100216 24V		
MC1C310ATE	102732 36V		
MC1C310ATF	102733 42V		
MC1C310ATG	100217 48V		
MC1C310ATH	102734 60V		
MC1C310ATI	102735 72V		
MC1C310ATJ	100218 110V		
MC1C310ATK	102736 120V		
MC1C310ATL	102737 125V		
MC1C310ATN	100219 220V		
MC1C310ATR	102738 240V		
MC1C400AIB	100420 12V		
MC1C400AID	100426 24V		
MC1C400ATB	100360 12V		
MC1C400ATD	100366 24V		
MC1C400ATE	103218 36V		
MC1C400ATF	103219 42V		
MC1C400ATG	100367 48V		
MC1C400ATH	103220 60V		
MC1C400ATI	103221 72V		
MC1C400ATJ	100368 110V		
MC1C400ATK	103222 120V		
MC1C400ATL	103223 125V		
MC1C400ATN	100369 220V		
MC1C400ATR	103224 240V		
MC1CB00AFD	100406 24V		
MC1CB00AFG	100407 48V		
MC1CB00AHD	103232 24V		
MC1CB00AID	100436 24V		
MC1CB00ATB	100370 12V		
MC1CB00ATC	103226 32V		
MC1CB00ATD	100376 24V		
MC1CB00ATE	103227 36V		
MC1CB00ATF	103228 42V		
MC1CB00ATG	100377 48V		
MC1CB00ATH	103229 60V		

Completed catalogue numbers

Intro

B

B

C

D

E

F

G

H

I

J/X



This list shows the catalogue and reference numbers for the contactors with the most usual voltages/types, please consult us.

Cat. no. Ref. no.

50Hz pg. A.53-A.55

Table with columns for Cat. no. and Ref. no. listing various contactor models like CL00A300TN, CL00A300TU, etc.

Table with columns for Cat. no. and Ref. no. listing various contactor models like LB1AN, LB1AU, LB3AN, etc.

Table with columns for Cat. no. and Ref. no. listing various contactor models like CL02AB00T7, CL03A300M1, etc.

Table with columns for Cat. no. and Ref. no. listing various contactor models like CL25A300T1, CL25A300T3, etc.

Table with columns for Cat. no. and Ref. no. listing various contactor models like CL04D400MN, CL04D800MB, etc.



This list shows the catalogue and reference numbers for the **contactors** with the most usual voltages/types, please consult us.

Cat. no.	Ref. no.	Cat. no.	Ref. no.	Cat. no.	Ref. no.
C04255V	110513 600V	CK10CE311D	133783 24/28V	KM4EWF	113551 48V (WR)
C04787C	110515 24V	CK10CE311F	113692 42/48V	KM4EWH	113552 72V (WR)
C04787F	119517 48V	CK10CE311J	133784 110/127V	KM4EWJ	113553 110V (WR)
C04787H	110518 110V	CK10CE311N	133286 220/250V	KM4EWN	113554 220V (WR)
C04787I	110519 120V	CK10CE311U	133785 380/415V	KM4EY	105318 440/500V
C04787M	110522 220V	CK10CE311Y	113694 440/500V	KM5ED	104870 24/28V
C04787S	110523 240V	CK10CE411D	133786 24/28V	KM5EF	104876 42/48V
C04787T	110525 380V	CK10CE411J	133787 110/127V	KM5EJ	104877 110/127V
C04787V	110526 440V	CK10CE411N	133287 220/250V	KM5EN	104878 220/250V
C04787Y	110529 600V	CK10CE411U	133788 380/415V	KM5EU	104879 380/415V
C12168C	105302 24V	CK11CE311D	133789 24/28V	KM5EWH	104871 72V (WR)
C12168F	105304 48V	CK11CE311F	113691 42/48V	KM5EY	110833 440/500V
C12168H	133886 110V	CK11CE311J	133790 110/127V	KM6ED	104880 24/28V
C12168I	104891 120V	CK11CE311N	133288 220/250V	KM6EF	104886 42/48V
C12168M	105308 220V	CK11CE311U	133791 380/415V	KM6EJ	104887 110/127V
C12168S	105309 240V	CK11CE311Y	113688 440/500V	KM6EN	104888 220/250V
C12168T	101060 380V	CK11CE411D	133792 24/28V	KM6EU	104889 380/415V
C12168V	105312 440V	CK11CE411F	113680 42/48V	KM6EY	110834 440/500V
C12168Y	133838 600V	CK11CE411J	133793 110/127V	KM7ED	113427 24/28V
CK07BA411C	110322 24V	CK11CE411N	133289 220/250V	KM7EF	113428 42/48V
CK07BA411F	110760 48V	CK11CE411U	133794 380/415V	KM7EJ	113429 110/127V
CK07BA411H	110325 110V	CK12BE311D	104516 24/28V	KM7EN	113430 220/250V
CK07BA411I	133798 120V	CK12BE311F	110304 42/48V	KM7EU	113431 380/415V
CK07BA411M	110330 220V	CK12BE311J	104518 110/127V	KM7EY	113432 440/500V
CK07BA411S	110331 240V	CK12BE311N	104519 220/250V		
CK07BA411T	110333 380V	CK12BE311U	110305 380/415V		
CK07BA411V	110334 440V	CK12BE311Y	110823 440/500V		
CK07BA411Y	110337 600V	CK12BE411D	104596 24/28V		
CK08BA411M	110348 220V	CK12BE411F	110383 42/48V		
CK08CA311F	113272 48V	CK12BE411J	104598 110/127V		
CK08CA311H	113130 110V	CK12BE411N	104599 220/250V		
CK08CA311M	111581 220V	CK12BE411U	110384 380/415V		
CK08CA311S	113890 240V	CK75CE311D	113106 24/28V		
CK08CA311V	113891 440V	CK75CE311F	108972 42/48V		
CK08CA311Y	101047 600V	CK75CE311J	113108 110/127V		
CK75CA311C	113100 24V	CK75CE311N	113109 220/250V		
CK75CA311F	113102 48V	CK75CE311U	113125 380/415V		
CK75CA311H	113111 110V	CK75CE311WD	113521 24V (WR)		
CK75CA311I	113112 120V	CK75CE311WE	113445 33V (WR)		
CK75CA311M	133219 220V	CK75CE311WF	113458 48V (WR)		
CK75CA311S	113894 240V	CK75CE311WH	113471 72V (WR)		
CK75CA311V	113895 440V	CK75CE311WJ	113484 110V (WR)		
CK75CA311Y	113122 600V	CK75CE311WN	113497 220V (WR)		
CK85BA311H	110267 110V	CK75CE311Y	113126 440/500V		
CK85BA311I	110268 120V	CK85BE311D	104476 24/28V		
CK85BA311M	110271 220V	CK85BE311F	110280 42/48V		
CK85BA311S	110272 240V	CK85BE311J	104478 110/127V		
CK85BA311V	110275 440V	CK85BE311N	104479 220/250V		
CK85BA311Y	101048 600V	CK85BE311U	110281 380/415V		
		CK95BE311D	104616 24/28V		
		CK95BE311F	104610 42/48V		
		CK95BE311J	104618 110/127V		
		CK95BE311N	104614 220/250V		
		CK95BE311U	104611 380/415V		
		CK95BE311WH	104617 72V (WR)		
		CK95BE311Y	113375 440/500V		
		CK95BE411D	104560 24/28V		
		CK95BE411F	110377 42/48V		
		CK95BE411J	104572 110/127V		
		CK95BE411N	104569 220/250V		
		CK95BE411U	110378 380/415V		
		KB4ED	104956 24/28V		
		KB4EF	133913 42/48V		
		KB4EJ	104957 110/127V		
		KB4EN	104958 220/250V		
		KB4EU	104959 380/415V		
		KB4EWD	113543 24V (WR)		
		KB4EWE	113544 33V (WR)		
		KB4EWF	113545 48V (WR)		
		KB4EWH	113546 72V (WR)		
		KB4EWJ	113547 110V (WR)		
		KB4EWN	113548 220V (WR)		
		KB4EY	105317 440/500V		
		KB5ED	104850 24/28V		
		KB5EF	104856 42/48V		
		KB5EJ	104857 110/127V		
		KB5EN	104858 220/250V		
		KB5EU	104859 380/415V		
		KB5EWH	104855 72V (WR)		
		KB5EY	110831 440/500V		
		KB6ED	104860 24/28V		
		KB6EF	104866 42/48V		
		KB6EJ	104867 110/127V		
		KB6EN	104868 220/250V		
		KB6EU	104869 380/415V		
		KB6EY	110832 440/500V		
		KB7ED	113675 24/28V		
		KB7EF	133911 42/48V		
		KB7EJ	113673 110/127V		
		KB7EN	113672 220/250V		
		KB7EU	113671 380/415V		
		KB7EY	113670 440/500V		
		KM4ED	104960 24/28V		
		KM4EF	104966 42/48V		
		KM4EJ	104967 110/127V		
		KM4EN	104968 220/250V		
		KM4EU	104969 380/415V		
		KM4EWD	113549 24V (WR)		
		KM4EWE	113550 33V (WR)		

Completed catalogue numbers

- Intro
- B
- B
- C
- D
- E
- F
- G
- H
- I
- J/X





This list shows the catalogue and reference numbers for the auxiliary minicontactors with the most usual voltages. For other voltages/types, please consult us.

Cat. no.	Ref. no.	Cat. no.	Ref. no.
50/60Hz		pg. B.9	
MBOA1	102407 24V	MCR031ATG	100017 48V
MBOA2	102408 42V	MCR031ATH	102327 60V
MBOA3	102409 110/115V	MCR031ATI	102328 72V
MBOA4	102410 120V	MCR031ATJ	100018 110V
MBOA5	102411 220V	MCR031ATK	102329 120V
MBOA6	102412 230V	MCR031ATL	102330 125V
MBOA7	102413 240V	MCR031ATN	100019 220V
MBOA8	102414 440V	MCR031ATR	102331 240V
MBOA9	133717 48V	MCR031ATS	102324 250V
MCR004AT1	102097 24V	MCR040AFD	100056 24V
MCR004AT2	102098 42V	MCR040AFG	100057 48V
MCR004AT3	102099 110/115V	MCR040AID	102332 24V
MCR004AT4	102100 120V	MCR040ATB	100000 12V
MCR004AT5	102101 220V	MCR040ATC	102315 32V
MCR004AT6	102102 230V	MCR040ATD	100006 24V
MCR004AT7	102103 240V	MCR040ATE	102316 36V
MCR004AT8	102104 440V	MCR040ATF	102317 42V
MCR004AT9	108859 48V	MCR040ATG	100007 48V
MCR013AT1	102076 24V	MCR040ATH	102318 60V
MCR013AT2	102077 42V	MCR040ATI	102319 72V
MCR013AT3	102078 110/115V	MCR040ATJ	100008 110V
MCR013AT4	102079 120V	MCR040ATK	102320 120V
MCR013AT5	102080 220V	MCR040ATL	102321 125V
MCR013AT6	102081 230V	MCR040ATN	100009 220V
MCR013AT7	102082 240V	MCR040ATR	102322 240V
MCR013AT8	102083 440V	MCR040ATS	100040 250V
MCR022AFB	107493 440V		
MCR022AIB	100129 220V		
MCR022AT1	102055 24V		
MCR022AT2	102056 42V		
MCR022AT3	102057 110/115V		
MCR022AT4	102058 120V		
MCR022AT5	102059 220V		
MCR022AT6	102060 230V		
MCR022AT7	102061 240V		
MCR022AT8	102062 440V		
MCR022AT9	108236 48V		
MCR031AT1	102034 24V		
MCR031AT2	102035 42V		
MCR031AT3	102036 110/115V		
MCR031AT4	102037 120V		
MCR031AT5	102038 220V		
MCR031AT6	102039 230V		
MCR031AT7	102040 240V		
MCR031AT8	102041 440V		
MCR031AT9	108238 48V		
MCR040AT1	102013 24V		
MCR040AT2	102014 42V		
MCR040AT3	102015 110/115V		
MCR040AT4	102016 120V		
MCR040AT5	102017 220V		
MCR040AT6	102018 230V		
MCR040AT7	102019 240V		
MCR040AT8	102020 440V		
MCR040AT9	108237 48V		
Direct current		pg. B.9	
MBOCA	102415 6V		
MBOCB	100460 12V		
MBOCC	102416 32V		
MBOCD	100466 24V		
MBOCE	102417 36V		
MBOCF	102418 42V		
MBOCG	100467 48V		
MBOCI	102420 72V		
MBOCJ	100468 110V		
MBOCK	102421 120V		
MBOCL	102422 125V		
MBOCN	100469 220V		
MBOCR	102423 240V		
MBOCS	100449 250V		
MBOCH	102419 60V		
MCR022AFG	100077 48V		
MCR022AFL	102366 125V		
MCR022AFN	100079 220V		
MCR022AID	100126 24V		
MCR022AIJ	100128 110V		
MCR022ATB	100020 12V		
MCR022ATC	102333 32V		
MCR022ATD	100026 24V		
MCR022ATE	102334 36V		
MCR022ATF	102335 42V		
MCR022ATG	100027 48V		
MCR022ATH	102336 60V		
MCR022ATI	102337 72V		
MCR022ATJ	100028 110V		
MCR022ATK	102338 120V		
MCR022ATL	102339 125V		
MCR022ATN	100029 220V		
MCR022ATR	102340 240V		
MCR022ATS	108953 250V		
MCR031AFD	100066 24V		
MCR031AID	100116 24V		
MCR031ATA	102323 6V		
MCR031ATB	100010 12V		
MCR031ATD	100016 24V		
MCR031ATE	102325 36V		
MCR031ATF	102326 42V		
50Hz		pg. B.9	
MBOAE	102397 32V		
MBOAF	102398 48V		
MBOAM	102401 208/220V		
MBOAU	213532 440V		
MBOAV	102406 600V		
MCR004ATE	102087 32V		
MCR004ATM	102091 208/220V		
MCR004ATU	100045 440V		
MCR004ATY	102096 600V		
MCR013ATE	102066 32V		
MCR013ATM	102070 208/220V		
MCR013ATU	100035 440V		
MCR013ATY	102075 600V		
MCR022AIU	100125 440V		
MCR022AIE	102045 32V		
MCR022ATH	102047 110V		
MCR022ATM	102049 208/220V		
MCR022ATI	100025 440V		
MCR022ATY	102054 600V		
MCR031AFU	100065 440V		
MCR031AIU	100115 440V		
MCR031ATE	102024 32V		
MCR031ATM	102028 208/220V		
MCR031ATU	100015 440V		
MCR031ATY	102033 600V		
MCR040ATE	102003 32V		
MCR040ATM	102007 208/220V		
MCR040ATU	100005 440V		
MCR040ATY	102012 600V		



This list shows the catalogue and reference numbers for the **auxiliary contactors** with the most usual voltages. For other voltages/types, please consult us.

Cat. no.	Ref. no.
RL4RA040T3	109018 110/115V
RL4RA040T4	109019 120V
RL4RA040T5	109020 220V
RL4RA040T6	109021 230V
RL4RA040T7	109022 240V
RL4RA040T8	109023 440V

Direct current	pg. B.15
LB1DB	112310 12V
LB1DD	112316 24V
LB1DE	112650 36V
LB1DF	112651 42V
LB1DG	112317 48V
LB1DH	112652 60V
LB1DI	112653 72V
LB1DJ	112318 110V
LB1DK	112654 120/125V
LB1DN	112319 220V
LB1DP	112655 230V
LB1DR	112656 240V
LB1DT	112657 250V
LB1DWB	113523 12V (WR)
LB1DWD	113524 24V (WR)
LB1DWE	113525 33V (WR)
LB1DWG	113526 48V (WR)
LB1DWI	113527 72V (WR)
LB1DWJ	113528 110V (WR)
LB1DWN	113529 220V (WR)
LB1DX	112658 440V

Cat. no.	Ref. no.
50Hz pg. B.15	
LB1AE	110401 32V
LB1AK	110405 127V
LB1AN	104634 220/230V
LB1AU	104635 380/400V
LB1AW	110412 415V
LB1AZ	110415 660/690V
RL4RA004TE	109073 32V
RL4RA004TK	109077 127V
RL4RA004TN	104034 220/230V
RL4RA004TU	104035 380/400V
RL4RA004TW	109084 415V
RL4RA004TZ	109087 660/690V
RL4RA022TE	109049 32V
RL4RA022TK	109053 127V
RL4RA022TN	104024 220/230V
RL4RA022TU	104025 380/400V
RL4RA022TW	109060 415V
RL4RA022TZ	109063 660/690V
RL4RA031TE	109025 32V
RL4RA031TK	109029 127V
RL4RA031TN	104014 220/230V
RL4RA031TU	104015 380/400V
RL4RA031TW	109036 415V
RL4RA031TZ	109039 660/690V
RL4RA040TE	109001 32V
RL4RA040TK	109005 127V
RL4RA040TN	104004 220/230V
RL4RA040TU	104005 380/400V
RL4RA040TW	109012 415V
RL4RA040TZ	109015 660/690V
RL4RD004TB	113030 12V
RL4RD004TD	113036 24V
RL4RD004TE	113077 36V
RL4RD004TG	113037 48V
RL4RD004TJ	113038 110V
RL4RD004TK	113081 120/125V
RL4RD004TN	113039 220V
RL4RD004TT	113084 250V
RL4RD022GD	113046 24V
RL4RD022GJ	113048 110V
RL4RD022TB	113020 12V
RL4RD022TD	113026 24V
RL4RD022TE	113068 36V
RL4RD022TG	113027 48V
RL4RD022TJ	113028 110V
RL4RD022TK	113072 120/125V
RL4RD022TN	113029 220V
RL4RD022TP	113073 230V
RL4RD022TT	113075 250V
RL4RD031TB	113010 12V
RL4RD031TD	113016 24V
RL4RD031TE	113059 36V
RL4RD031TG	113017 48V
RL4RD031TH	113061 60V
RL4RD031TJ	113018 110V
RL4RD031TK	113063 120/125V
RL4RD031TN	113019 220V
RL4RD031TT	113066 250V
RL4RD031TX	113067 440V
RL4RD040TB	113000 12V
RL4RD040TD	113006 24V
RL4RD040TE	113050 36V
RL4RD040TG	113007 48V
RL4RD040TJ	113008 110V
RL4RD040TK	113054 120/125V
RL4RD040TN	113009 220V
RL4RD040TT	113057 250V

50/60Hz	pg. B.15
LB1AL	110406 208V
LB1AT	110410 380V
LB1AV	110414 600V
RL4RA004TL	109078 208V
RL4RA004TT	109082 380V
RL4RA004TY	109086 600V
RL4RA022TL	109054 208V
RL4RA022TT	109058 380V
RL4RA022TY	109062 600V
RL4RA031TL	109030 208V
RL4RA031TT	109034 380V
RL4RA031TY	109038 600V
RL4RA040TL	109006 208V
RL4RA040TT	109010 380V
RL4RA040TY	109014 600V

50/60Hz	pg. B.15	Mechanical latch blocks	pg. B.16
LB1A1	110416 24V	RMLFD	112992
LB1A2	110417 42V	RMLFG	112993
LB1A3	110418 110/115V	RMLFJ	112994
LB1A4	110419 120V	RMLFN	112995
LB1A5	110420 220V	RMLFU	112996
LB1A6	110421 230V	RMLFY	112997
LB1A7	110422 240V		
LB1A8	110423 440V		
LB1A9	113979 48V		
RL4RA004T1	109088 24V		
RL4RA004T2	109089 42V		
RL4RA004T3	109090 110/115V		
RL4RA004T4	109091 120V		
RL4RA004T5	109092 220V		
RL4RA004T6	109093 230V		
RL4RA004T7	109094 240V		
RL4RA004T8	109095 440V		
RL4RA022T1	109064 24V		
RL4RA022T2	109065 42V		
RL4RA022T3	109066 110/115V		
RL4RA022T4	109067 120V		
RL4RA022T5	109068 220V		
RL4RA022T6	109069 230V		
RL4RA022T7	109070 240V		
RL4RA022T8	109071 440V		
RL4RA031T1	109040 24V		
RL4RA031T2	109041 42V		
RL4RA031T3	109042 110/115V		
RL4RA031T4	109043 120V		
RL4RA031T5	109044 220V		
RL4RA031T6	109045 230V		
RL4RA031T7	109046 240V		
RL4RA031T8	109047 440V		
RL4RA040T1	109016 24V		
RL4RA040T2	109017 42V		

Completed catalogue numbers

- Intro
- B
- B
- C
- D
- E
- F
- G
- H
- I
- J/X



This list shows the catalogue and reference numbers for the **control and signalling units** Ø 22 mm with the most usual colours. For other types, please consult us.

Cat. no.	Ref. no.	
P9XEM3LN	185036	bleu
P9XEM3NN	185030	black
P9XEM4VN	185042	green
P9XEM4RN	185041	red
P9XEM4GN	185043	yellow
P9XEM4LN	185046	bleu
P9XEM4NN	185040	black
P9XET4VN1	185062	green
P9XET4RN1	185061	red
P9XET4GN1	185063	yellow
P9XET4LN1	185066	bleu
P9XET4NN1	185057	black

Cat. no.	Ref. no.		Emergency illuminated	
Push-buttons				
standard pg. F.11				
P9XPNVG	185002	green	P9XEM4VL 185552 green	
P9XPNRG	185001	red	P9XEM4RL 185551 red	
P9XPNGG	185003	yellow	P9XEM4GL 185553 yellow	
P9XPNLG	185006	bleu	P9XEM4LL 185556 bleu	
P9XPNBG	185007	white	P9XEM4BL 185557 white	
P9XPNNG	185000	black	P9XEM4AL 185555 amber	
P9XPNHG	185008	grey	P9XEM4IL 185558 clear	
P9XPNMG	185004	brown	P9XET4VL1 185562 green	
P9XPNOG	185009	w/o button	P9XET4RL1 185561 red	
P9XPNVS	185012	green	P9XET4GL1 185563 yellow	
P9XPNRS	185011	red	P9XET4LL1 185566 bleu	
P9XPNGS	185013	yellow	P9XET4BL1 185567 white	
P9XPNLS	185016	bleu	P9XET4AL1 185565 amber	
P9XPNBS	185017	white	P9XET4IL1 185568 clear	
P9XPNNS	185010	black	Selector switches	
P9XPNHS	185018	grey	not illuminated pg. F.12/13	
P9XPNMS	185014	brown	P9XSMD5V 185142 green	
P9XPNOS	185019	w/o button	P9XSMD5R 185141 red	
P9MPNVE	184022	green	P9XSMD5G 185143 yellow	
P9MPNRE	184021	red	P9XSMD5L 185146 bleu	
P9MPNGE	184023	yellow	P9XSMD5N 185140 black	
P9MPNLE	184026	bleu	Illuminated selector	
P9MPNBE	184027	white	switches pg. F.16	
P9MPNNE	184020	black	P9XSLD0V 185592 green	
P9MPNHE	184028	grey	P9XSLD0R 185591 red	
P9MPNME	184024	brown	P9XSLD0G 185593 yellow	
P9MPNOE	184029	w/o button	P9XSLD0L 185596 bleu	
Illuminated				
push-buttons pg. F.16				
P9XPLVGD	185492	green	P9XSLD08 185597 white	
P9XPLRGD	185491	red	P9XSLD0A 185595 amber	
P9XPLGGD	185493	yellow	P9XSLD0I 185598 clear	
P9XPLLGD	185496	bleu	P9XSLZ0V 185602 green	
P9XPLBGD	185497	white	P9XSLZ0R 185601 red	
P9XPLAGD	185495	amber	P9XSLZ0G 185603 yellow	
P9XPLIGD	185498	clear	P9XSLZ0L 185606 bleu	
P9XPLVSD	185502	green	P9XSLZ0B 185607 white	
P9XPLRSD	185501	red	P9XSLZ0A 185605 amber	
P9XPLGSD	185503	yellow	P9XSLZ0I 185608 clear	
P9XPLSD	185506	bleu	Selector switches	
P9XPLBSD	185507	white	with key, pg. F.14/15	
P9XPLASD	185505	amber	P9XSCE0T95 185418 Func. E	
P9XPLISD	185508	clear	P9XSCL0T95 185425 Func. L	
P9MPLVED	184512	green	P9XSJU0T95 185432 Func. U	
P9MPLRED	184511	red	P9XSCE3C95 185464 Func. E	
P9MPLGED	184513	yellow	P9XSCL3C95 185465 Func. L	
P9MPLLED	184516	bleu	P9XSJU3C95 185466 Func. U	
P9MPLBED	184517	white	P9XSCE1N95 185442 Func. E	
P9MPLAED	184515	amber	P9XSCL1N95 185445 Func. L	
P9MPLIED	184518	clear	P9XSJU1N95 185448 Func. U	
Pilot lights pg. F.18				
P9XLVD	185792	green	P9XSCE5H95 185454 Func. E	
P9XLRD	185791	red	P9XSCL5H95 185457 Func. L	
P9XLGD	185793	yellow	P9XSJU5H95 185460 Func. U	
P9XLDD	185796	bleu	Not illuminated	
P9XLBD	185797	white	selector switches, pg. F.12/13	
P9XLAD	185795	amber	P9TSMV0N 191350 black	
P9XLID	185798	clear	P9TSMW0N 191360 black	
Pilot lights				
unibloc pg. F.18				
P9XUVDDO	185822	green	P9XSJV0V 183897 green	
P9XURDDO	185821	red	P9XSJV0R 183896 red	
P9XUGDDO	185823	yellow	Power supplies,	
P9XULDDO	185826	bleu	integrated LED pg. F.23	
P9XUBDDO	185827	white	P9PLNBDA 197036 amber	
P9XUADD0	185825	amber	P9PLNBDB 197037 white	
P9XUIDD0	185828	clear	P9PLNB DG 197038 yellow	
P9XUVDNR	185842	green	P9PLNBDL 197039 bleu	
P9XURDRN	185841	red	P9PLNBDR 197040 red	
P9XUGDRN	185843	yellow	P9PLNB DV 197041 green	
P9XULDRN	185846	bleu		
P9XUBDRN	185847	white		
P9XUADRN	185845	amber		
P9XUIDRN	185848	clear		

Cat. no.	Ref. no.		Emergency illuminated
Push-buttons			
standard pg. F.11			
P9XEM3VN	185032	green	
P9XEM3RN	185031	red	
P9XEM3GN	185033	yellow	

This list shows the catalogue and reference numbers for the **control and signalling units** Ø 30 mm with the most usual colours. For other types, please consult us.

Cat. no.	Ref. no.	
Mushroom head caps pg. F.43		
077EN	180070	black
077ER	180071	red
077EG	180073	yellow

Cat. no.	Ref. no.	
Selector switches		
with knob - 2 positions pg. F.44		
077SHN11	180180	black
077SHR11	180181	red
077SHV11	180182	green

Cat. no.	Ref. no.	
Illuminated push-buttons - Lenses pg. F.47		
077GPLR	180961	red
077GPLV	180962	green
077GPLG	180963	yellow
077GPLA	180965	orange
077GPLBL	180966	bleu
077GPLB	180967	white
077GPLI	180968	clear

Cat. no.	Ref. no.	
Illuminated selector switches		
Lenses pg. F.48		
077MISR	181151	red
077MISV	181152	green
077MISG	181153	yellow

Cat. no.	Ref. no.	
Illuminated selector switches - 3 positions pg. F.48		
077ISB11TJRC	181225	110-120V

Cat. no.	Ref. no.	
Pilot lights - Lenses pg. F.48/49		
077GLR	181401	red
077GLV	181402	green
077GLG	181403	yellow
077GLA	181405	orange
077GLBL	181406	bleu
077GLB	181407	white
077GLI	181408	clear
099GW1R	181271	red
099GW1V	181272	green
099GW1A	181275	orange
099GW1BL	181276	bleu
099GW1B	181277	white
099GW1I	181278	clear

Cat. no.	Ref. no.	
Accessories pg. F.50		
077MN	181590	black
077MR	181591	red
077MV	181592	green
077MG	181593	yellow
077MBL	181596	bleu
077CPN	181580	black
077CPR	181581	red
077CPV	181582	green
077CPG	181583	yellow
BA9S6LR	187871	red
BA9S6LV	187872	green
BA9S6LG	187873	yellow
BA9S6LB	187875	white
BA9S12LR	187881	black
BA9S12LV	187882	green
BA9S12LG	187883	yellow
BA9S24LR	187891	black
BA9S24LV	187892	green
BA9S24LG	187893	yellow
BA9S24LB	187895	White
BA9S48LR	187901	black
BA9S48LV	187902	green
BA9S48LG	187903	yellow
BA9S110LR	187911	black
BA9S110LV	187912	green
BA9S110LG	187913	yellow
BA9S110LB	187915	white
BA9S230LR	187921	red
BA9S230LG	187922	yellow
BA9S230LB	187926	white



Cat. no	Ref. no.	Page	Cat. no	Ref. no.	Page	Cat. no	Ref. no.	Page	Cat. no	Ref. no.	Page
077...			077SBN11SC	180240	F.44	080SP1MSFC	170838	F.27	390...		
077-01	180003	F.51	077SCB1120	180843	F.45	080SP1MSFE	170839	F.27	390/3921/2FOM4/	214120	A.155
077-01R	180008	F.51	077SCB11DC07	180852	F.45	080SP15F	170837	F.27	390/3921PFRN	244173	A.155
077-10	180002	F.51	077SCB11RC03	180853	F.45	080SP15FC	170835	F.27	390/3921PFZCS14	202273	A.155
077-10A	180007	F.51	077SCD1101	180630	F.45	080SP15FE	170836	F.27	390/3921PFZCS25	244172	A.155
077-11	180001	F.51	077SCD1105	180631	F.45	080SP2	170802	F.27	390/3921PFZCS45	202274	A.155
077C3095	173095	F.31	077SCD1109	180632	F.45	080SP24	170810	F.27	390/3921PMRN	202275	A.155
077C3353	173353	F.31	077SCH11SC03	180636	F.45	080SP24SFE	170862	F.27	390/3921PMZI	202276	A.155
077C9901	173901	F.31	077SCI11DC03	180640	F.45	080SP2M	170832	F.27	390/3921PZ	202277	A.155
077C9902	173902	F.31	077SC222DC01	180906	F.45	080SP2MSF	170846	F.27	390/3922FOM5/2	214121	A.155
077C9903	173903	F.31	077SDN11	180170	F.44	080SP2MSFC	170844	F.27	390/3922PFRN	212709	A.155
077C9904	173904	F.31	077SHN11	180180	F.44	080SP2MSFE	170845	F.27	390/3922PFZCS45	244744	A.155
077C9905	173905	F.31	077SLB11	180607	F.44	080SP2SF	170843	F.27	390/3922PFZCS90	202278	A.155
077C9910	173910	F.31	077SLD11	180601	F.44	080SP2SFC	170841	F.27	390/3922PMRN	213014	A.155
077C9916	173916	F.31	077SLX22	180606	F.44	080SP2SFE	170842	F.27	390/3922PMZI	202279	A.155
077C9919	173919	F.31	077SLZ22	180623	F.44	080SP3	170803	F.27	390/3922PZ	202280	A.155
077CF73033	173033	F.31	077SLZ22DC	180625	F.44	080SP35	170811	F.27	390/3923/2FOM4/	214122	A.155
077CF73034	173034	F.31	077SLZ22RC	180626	F.44	080SP35SF	170865	F.27	390/3923FOM5/2	214123	A.155
077CF73037	173037	F.31	077SN22RC	180510	F.44	080SP35SFC	170863	F.27	390/3923PFRN	213986	A.155
077CF73038	173038	F.31	077SP1	180521	F.52	080SP35SFE	170864	F.27	390/3923PFZCS125	202281	A.155
077CF73040	173040	F.31	077SP12	180530	F.52	080SP35F	170849	F.27	390/3923PFZCS75	244745	A.155
077CPLT	181600	F.50	077SP12SFE	180545	F.52	080SP35FC	170847	F.27	390/3923PMRN	202282	A.155
077CPT	181588	F.50	077SP16	180531	F.52	080SP35FE	170848	F.27	390/3923PMZI	202283	A.155
077C455	173455	F.31	077SP16SFE	180546	F.52	080SP4	170804	F.27	390/3923PZ	202284	A.155
077CST	181603	F.50	077SP1M	180522	F.52	080SP4M	170834	F.27	390/3924F4	214124	A.155
077DAE	181554	F.50	077SP1MSFE	180537	F.52	080SP4MSFE	170851	F.27	390/3924F5/2	204178	A.155
077DLE14	181260	F.49	077SP1SFE	180536	F.52	080SP4SFE	170850	F.27	390/3924M4/2	214126	A.155
077DPP	181550	F.50	077SP2	180523	F.52	080SP6	170806	F.27	390/3924M5/2	214127	A.155
077E01	180069	F.43	077SP20	180532	F.52	080SP6SFE	170852	F.27	390/3924PFRN	202287	A.155
077E10	180059	F.43	077SP20SFE	180547	F.52	080SP8	170807	F.27	390/3924PFZCS125	202288	A.155
077E11	180049	F.43	077SP25	180533	F.52	080SP8SFE	170855	F.27	390/3924PFZCS200	202289	A.155
077E11	181602	F.43	077SP25SFE	180548	F.52	080SP8SFC	170853	F.27	390/3924PMRN	202290	A.155
077E11	181620	F.50	077SP2M	180524	F.52	080SP8SFE	170854	F.27	390/3924PMZI	202291	A.155
077GELR	180971	F.47	077SP2MSFE	180539	F.52	080XTG8	179515	F.32	390/3924PZ	202292	A.155
077GG03	180980	F.47	077SP2SFE	180538	F.52	080XTG801	179535	F.32	390/3925F4/2	214128	A.155
077GGBCF	180137	F.42	077SP3	180525	F.52	080XTG802	179536	F.32	390/3925F5/2	214129	A.155
077GGBCN	180020	F.42	077SP30	180534	F.52	080XTG803	179511	F.32	390/3925M4/2	214130	A.155
077GGBCS	180050	F.42	077SP30SFE	180549	F.52	080XTG804	179537	F.32	390/3925M5/2	214131	A.155
077GGM	180981	F.47	077SP36	180535	F.52	080XTG805	179538	F.32	390/3925PFRN	244746	A.155
077GGT	180982	F.47	077SP36SFE	180554	F.52	080XTG806	179539	F.32	390/3925PFZCS150	213573	A.155
077GSBCF	180136	F.42	077SP36SFC	180552	F.52	080XTG807	179540	F.32	390/3925PFZCS320	202295	A.155
077GSBCN	180010	F.42	077SP36SFE	180550	F.52	080XTG808	179541	F.32	390/3925PMRN	202297	A.155
077GSBCS	180040	F.42	077SP3SFE	180540	F.52	080XTGR	179514	F.32	390/3925PMZI	202298	A.155
077ISB11D0	181170	F.48	077SP4	180527	F.52	080XTGR01	179525	F.32	390/3925PZ	202299	A.155
077ISB11D0RC	181174	F.48	077SP4SFE	180542	F.52	080XTGR02	179526	F.32	390/3926F4/2	214133	A.155
077ISD11D0	181060	F.48	077SP4V	180526	F.52	080XTGR03	179510	F.32	390/3926F5/2	214134	A.155
077ISZ11D0RC	181176	F.48	077SP4VSF	180553	F.52	080XTGR04	179527	F.32	390/3926M4/2	214135	A.155
077LDMVD	181305	F.49	077SP4VSFC	180551	F.52	080XTGR05	179528	F.32	390/3926M5/2	214136	A.155
077LDNV0	181300	F.49	077SP4VSFE	180541	F.52	080XTGR06	179529	F.32	390/3926PFZCS270	202303	A.155
077LRNVJ	181301	F.49	077SP6	180528	F.52	080XTGR07	179530	F.32	390/3926PFZCS450	213574	A.155
077LRNVN	181302	F.49	077SP6SFE	180543	F.52	080XTGR08	179531	F.32	390/3926PMZI	202304	A.155
077M2S2SX44	180914	F.46	077SP9	180529	F.52	090...			390/3926PZ	202654	A.155
077M2S2SX44B	181004	F.46	077SP9SFE	180544	F.52	090M11	130310	G.38	390/3927F4/2	214137	A.156
077M2S2TX44	180918	F.46	077SUN22	180440	F.44	090M12	130311	G.38	390/3927F5/2	214138	A.156
077M2T2TX44	180915	F.46	077S2N22	180480	F.44	099...			390/3927M4/2	214139	A.156
077M2T2TX44B	181005	F.46	077TGR	181650	F.51	099SPDDB	180009	F.51	390/3927M5/2	214140	A.156
077M2T2TY44	180919	F.46	077TGRO2	181840	F.51	105...			390/3927PFRN	202306	A.156
077M4S4TX88	180923	F.46	077TNA	181660	F.51	105 CI	132242	F.59	390/3927PFZCS320	202307	A.156
077M4S4TX88B	181008	F.46	077TNA2	181670	F.51	105 CI 10	132243	F.59	390/3927PFZCS630	202308	A.156
077M4T4TX88	180921	F.46	077TNA230	181951	F.51	105 GIL	132240	F.59	390/3927PMRN	202309	A.156
077M4T4TY88	180927	F.46	077TNA3	181962	F.51	105 GIL 10	132241	F.59	390/3927PZ	202311	A.156
077M4T4TY88B	181009	F.46	077TNA301	181963	F.51	105 PM	132244	F.59	390/392PMZI	202310	A.156
077MT1234S22	180931	F.46	077TNA312	181720	F.51	105 PT	132234	F.58	39012Y110D	202323	A.154
077MT1234S22B	181021	F.46	077TNA313	181722	F.51	105DTL220	132230	F.58	39012Y125D	202324	A.154
077MT24S22	180911	F.46	077TNA40	181930	F.51	105DTL500	132231	F.58	39012Y197D	202325	A.154
077MT24S22B	181001	F.46	077TPF	181601	F.50	105DTL690	132232	F.58	39012Y20D	244107	A.154
077MT24S22R	180913	F.46	080...			105GP1P220	132250	F.58	39012Y220D	202326	A.154
077MT24S22RB	181003	F.46	080CPDT	173208	F.10	105GP1P220M	132251	F.58	39012Y230D	211706	A.154
077MTS123422	180929	F.46	080ESL	170212	F.30	105GP1P500	132252	F.58	39012Y240D	202327	A.154
077MTS123422B	181019	F.46	080KCSF	170883	F.27	105GP1P500M	132253	F.58	39012Y40D	244106	A.154
077MTS2422	180910	F.46	080QDF	173220	F.29	105PT	132234	G.29	39012Y48D	244734	A.154
077MTS2422B	181000	F.46	080QDF001	187715	F.29	114...			39012Y97D	202328	A.154
077MTS2422R	180912	F.46	080QDF002	187716	F.29	114FCT03	130320	G.29	3903Y110D	202437	A.154
077MTS2422RB	181002	F.46	080QDF006	187705	F.29	114FCT03T	130321	G.29	3903Y125D	216100	A.154
077OPZ	181570	F.50	080QDF017	187709	F.29	114FCT12	200909	G.29	3903Y197D	214442	A.154
077P01	180039	F.42	080QDF018	187710	F.29	114FCT21	200910	G.29	3903Y20D	215278	A.154
077P10	180029	F.42	080QDF026	187711	F.29	115...			3903Y220D	202438	A.154
077P11	180019	F.42	080QDF027	185788	F.29	115803SP	132563	G.38	3903Y230D	211107	A.154
077P11T180	180121	F.42	080QDF028	187702	F.29	115804SP	132565	G.38	3903Y24D	244735	A.154
077P11T30	180120	F.42	080QDF029	187701	F.29	115805SP	132564	G.38	3903Y40D	244088	A.154
077PC11C	180100	F.43	080QDF030	185789	F.29	115806SPPA	215320	G.38	3903Y48D	212705	A.154
077PC11G	180104	F.43	080QDF031	187713	F.29	1158067SPPA	215321	G.38	3903Y97D	213691	A.154
077PLM10D0	181043	F.47	080QDF032	187714	F.29	115807SP	132562	G.38	3904Y110D	202479	A.154
077PLM11D0	181040	F.47	080QDF201	187719	F.29	115CA	132571	G.38	3904Y125D	202480	A.154
077PLM20D0	181041	F.47	080QDF202	187720	F.29	115PC002	132500	G.38	3904Y197D	202481	A.154
077PTB01	181609	F.51	080SP1	170801	F.27	115PC002A	215253	G.38	3904Y20D	244084	A.154
077PTB10	181608	F.51	080SP12	170808	F.27	115PC015	132501	G.38	3904Y220D	202482	A.154
077PTB11	181615	F.51	080SP12SFE	170858	F.27	115PC015A	215252	G.38	3904Y230D	211708	A.154
077RE01	180099	F.43	080SP12SFC	170856	F.27	115PC018	132502	G.38	3904Y24D	202483	A.154
077RE10	180089	F.43	080SP12SFE	170857	F.27	115PC018A	241311	G.38	3904Y40D	244083	A.154
077RE11	180079	F.43	080SP18	170809	F.27	115PC119	132503	G.38	3904Y48D	213814	A.154
077RER	180090	F.43	080SP18SF	170861	F.27	11					

Cat. no	Ref. no.	Page	Cat. no	Ref. no.	Page	Cat. no	Ref. no.	Page	Cat. no	Ref. no.	Page
3905Y220D	212706	A.154	6KFP43005X4XXXXA1		H.55	6KFP63060X2XXCA1		H.54	6KGP23030X2XXXXA1	404721	H.36
3905Y230D	211709	A.154	6KFP43005X9XXXXA1	403858	H.53	6KFP63075X1XXCA1		H.53	6KGP23030X4XBXA1		H.37
3905Y24D	244072	A.154	6KFP43007X2XXXXA1	403890	H.54	6KFP63075X2XXCA1		H.54	6KGP23030X4XXXXA1	404735	H.38
3905Y40D	244071	A.154	6KFP43007X4XXXXA1		H.55	6KFP63100X1XXCA1		H.53	6KGP23030X9XBXA1		H.33
3905Y48D	244736	A.154	6KFP43007X9XXXXA1	403859	H.53	6KFP63100X2XXCA1		H.54	6KGP23030X9XXXXA1	404681	H.34
3905Y97D	202513	A.154	6KFP43010X2XXXXA1	403891	H.54	6KFP63125X1XXCA1		H.53	6KGP23040X2XBXA1		H.35
3906Y110D	202532	A.154	6KFP43010X4XXXXA1		H.55	6KFP63125X2XXCA1		H.54	6KGP23040X2XXXXA1	404722	H.36
3906Y125D	211711	A.154	6KFP43010X9XXXXA1	403860	H.53	6KFP63150X2XXCA1		H.54	6KGP23040X4XBXA1		H.37
3906Y197D	244066	A.154	6KFP43015X2XXXXA1	403892	H.54	6KFP63150X8XXCA1		H.53	6KGP23040X4XXXXA1	404736	H.38
3906Y20D	244065	A.154	6KFP43015X4XXXXA1		H.55	6KFP631K0X1XXCA1		H.53	6KGP23040X9XBXA1		H.33
3906Y220D	213612	A.154	6KFP43015X9XXXXA1	403861	H.53	6KFP631K0X2XXCA1		H.54	6KGP23040X9XXXXA1	404682	H.34
3906Y230D	211770	A.154	6KFP43020X2XXXXA1	403893	H.54	6KFP631K1X1XXCA1		H.53	6KGP23050X2XBXA1		H.35
3906Y24D	244064	A.154	6KFP43020X4XXXXA1		H.55	6KFP631K1X2XXCA1		H.54	6KGP23050X2XXXXA1	404723	H.36
3906Y40D	244063	A.154	6KFP43020X9XXXXA1	403862	H.53	6KFP631K2X1XXCA1		H.53	6KGP23050X4XBXA1		H.37
3906Y48D	212707	A.154	6KFP43025X2XXXXA1	403894	H.54	6KFP631K2X2XXCA1		H.54	6KGP23050X4XXXXA1	404737	H.38
3906Y97D	202533	A.154	6KFP43025X4XXXXA1		H.55	6KFP631K3X1XXCA1		H.53	6KGP23050X9XBXA1		H.33
3907Y110D	202547	A.154	6KFP43025X9XXXXA1	403863	H.53	6KFP631K3X2XXCA1		H.54	6KGP23050X9XXXXA1	404683	H.34
3907Y125D	211713	A.154	6KFP43030X2XXXXA1	403895	H.54	6KFP631K6X1XXCA1		H.53	6KGP23F33X2XBXA1		H.35
3907Y197D	244059	A.154	6KFP43030X4XXXXA1		H.55	6KFP631K6X2XXCA1		H.54	6KGP23F33X2XXXXA1	404710	H.36
3907Y20D	244058	A.154	6KFP43030X9XXXXA1	403864	H.53	6KFP631K9X1XXCA1		H.53	6KGP23F33X4XBXA1		H.37
3907Y220D	202548	A.154	6KFP43040X2XXXXA1	403896	H.54	6KFP63200X2XXCA1		H.54	6KGP23F33X4XXXXA1	404724	H.38
3907Y230D	211712	A.154	6KFP43040X4XXXXA1		H.55	6KFP63200X8XXCA1		H.53	6KGP23F33X9XBXA1		H.33
3907Y24D	244057	A.154	6KFP43040X9XXXXA1	403865	H.53	6KFP63250X2XXCA1		H.54	6KGP23F33X9XXXXA1	404670	H.34
3907Y40D	244056	A.154	6KFP43050X2XXXXA1	403897	H.54	6KFP63250X8XXCA1		H.53	6KGP23F50X2XBXA1		H.35
3907Y48D	244737	A.154	6KFP43050X4XXXXA1		H.55	6KFP63300X2XXCA1		H.54	6KGP23F50X2XXXXA1	404711	H.36
3907Y97D	244738	A.154	6KFP43050X9XXXXA1	403866	H.53	6KFP63300X8XXCA1		H.53	6KGP23F50X4XBXA1		H.37
3908/9M4/2	214141	A.156	6KFP43060X2XXXXA1	403898	H.54	6KFP63350X2XXCA1		H.54	6KGP23F50X4XXXXA1	404725	H.38
3908/9M5/2	214142	A.156	6KFP43060X4XXXXA1		H.55	6KFP63350X8XXCA1		H.53	6KGP23F50X9XBXA1		H.33
3908F4/2	214144	A.156	6KFP43060X9XXXXA1	403867	H.53	6KFP63400X2XXCA1		H.54	6KGP23F50X9XXXXA1	404671	H.34
3908F5/2	214145	A.156	6KFP43075X2XXXXA1	403899	H.54	6KFP63450X8XXCA1		H.53	6KGP43001X2XBXA1	403157	H.35
3908PFZCS400	202555	A.156	6KFP43075X4XXXXA1		H.55	6KFP63500X2XXCA1		H.54	6KGP43001X2XXXXA1	402889	H.36
3908PFZCS800	202562	A.156	6KFP43075X9XXXXA1	403868	H.53	6KFP63550X2XXCA1		H.54	6KGP43001X4XBXA1	403188	H.37
3908PMZ	202563	A.156	6KFP43100X2XXXXA1	403900	H.54	6KFP63550X8XXCA1		H.53	6KGP43001X4XXXXA1	402920	H.38
3908PZ	202564	A.156	6KFP43100X4XXXXA1		H.55	6KFP63600X8XXCA1		H.53	6KGP43001X9XBXA1	403117	H.33
3908Y110D	202565	A.154	6KFP43100X9XXXXA1	403869	H.53	6KFP63650X2XXCA1		H.54	6KGP43001X9XXXXA1	400451	H.34
3908Y197D	214066	A.154	6KFP43125X2XXXXA1	403901	H.54	6KFP63650X8XXCA1		H.53	6KGP43002X2XBXA1	403158	H.35
3908Y220D	202566	A.154	6KFP43125X4XXXXA1		H.55	6KFP63750X2XXCA1		H.54	6KGP43002X2XXXXA1	402890	H.36
3908Y97D	212959	A.154	6KFP43125X9XXXXA1	403870	H.53	6KFP63750X8XXCA1		H.53	6KGP43002X4XBXA1	403189	H.37
3909F4/2	204179	A.156	6KFP43150X2XXXXA1	403902	H.54	6KFP63900X2XXCA1		H.54	6KGP43002X4XXXXA1	402921	H.38
3909F5/2	204180	A.156	6KFP43150X4XXXXA1		H.55	6KFP63900X8XXCA1		H.53	6KGP43002X9XBXA1	403118	H.33
3909PFZCS120	244983	A.156	6KFP43150X8XXXXA1	403871	H.53	6KGP23001X2XBXA1		H.35	6KGP43002X9XXXXA1	401212	H.34
3909PMZ	212962	A.156	6KFP431K0X1XXCA1	403883	H.53	6KGP23001X2XXXXA1	404712	H.36	6KGP43003X2XBXA1	403159	H.35
3909Y110D	202572	A.154	6KFP431K0X2XXCA1	403914	H.54	6KGP23001X4XBXA1		H.37	6KGP43003X2XXXXA1	402891	H.36
3909Y197D	204181	A.154	6KFP431K0X4XXCA1		H.55	6KGP23001X4XXXXA1	404726	H.38	6KGP43003X4XBXA1	403190	H.37
3909Y220D	244739	A.154	6KFP431K2X1XXCA1	403884	H.53	6KGP23001X9XBXA1		H.33	6KGP43003X4XXXXA1	402922	H.38
3909Y97D	214146	A.154	6KFP431K2X2XXCA1	403915	H.54	6KGP23001X9XXXXA1	404672	H.34	6KGP43003X9XBXA1	403119	H.33
6KF...			6KFP431K2X4XXCA1		H.55	6KGP23001X9XXXXA1		H.35	6KGP43003X9XXXXA1	401362	H.34
6KFP23001X2XXXXA1	404697	H.54	6KFP431K3X1XXCA1	403885	H.53	6KGP23002X2XBXA1		H.35	6KGP43005X2XBXA1	403160	H.35
6KFP23001X4XXXXA1		H.55	6KFP431K3X2XXCA1	403916	H.54	6KGP23002X4XBXA1	404713	H.36	6KGP43005X2XXXXA1	402892	H.36
6KFP23001X9XXXXA1	404684	H.53	6KFP431K3X4XXCA1		H.55	6KGP23002X4XXXXA1	404727	H.38	6KGP43005X4XBXA1	403191	H.37
6KFP23002X2XXXXA1	404698	H.54	6KFP431K3X8XXCA1	403903	H.54	6KGP23002X9XBXA1		H.33	6KGP43005X4XXXXA1	402923	H.38
6KFP23002X4XXXXA1		H.55	6KFP43200X2XXXXA1		H.55	6KGP23002X9XXXXA1	404673	H.34	6KGP43005X9XBXA1	403120	H.33
6KFP23002X9XXXXA1	404685	H.53	6KFP43200X8XXXXA1	403872	H.53	6KGP23002X9XXXXA1		H.34	6KGP43005X9XXXXA1	402735	H.34
6KFP23003X2XXXXA1	404699	H.54	6KFP43250X2XXXXA1	403904	H.54	6KGP23003X2XBXA1		H.35	6KGP43007X2XBXA1	403161	H.35
6KFP23003X4XXXXA1		H.55	6KFP43250X4XXXXA1		H.55	6KGP23003X2XXXXA1	404714	H.36	6KGP43007X2XXXXA1	402893	H.36
6KFP23003X9XXXXA1	404686	H.53	6KFP43250X8XXXXA1	403873	H.53	6KGP23003X4XBXA1		H.37	6KGP43007X4XBXA1	403192	H.37
6KFP23005X2XXXXA1	404700	H.54	6KFP43300X2XXXXA1	403905	H.54	6KGP23003X4XXXXA1	404728	H.38	6KGP43007X4XXXXA1	402924	H.38
6KFP23005X4XXXXA1		H.55	6KFP43300X4XXXXA1		H.55	6KGP23003X9XBXA1		H.33	6KGP43007X9XBXA1	403121	H.33
6KFP23005X9XXXXA1	404687	H.53	6KFP43300X8XXXXA1	403874	H.53	6KGP23003X9XXXXA1	404674	H.34	6KGP43007X9XXXXA1	402738	H.34
6KFP23007X2XXXXA1	404701	H.54	6KFP43350X2XXXXA1	403906	H.54	6KGP23005X2XBXA1		H.35	6KGP43010X2XBXA1	403162	H.35
6KFP23007X4XXXXA1		H.55	6KFP43350X4XXXXA1		H.55	6KGP23005X2XXXXA1	404715	H.36	6KGP43010X2XXXXA1	402894	H.36
6KFP23007X9XXXXA1	404688	H.53	6KFP43350X8XXXXA1	403875	H.53	6KGP23005X4XBXA1		H.37	6KGP43010X4XBXA1	403193	H.37
6KFP23010X2XXXXA1	404702	H.54	6KFP43450X2XXCA1	403907	H.54	6KGP23005X4XXXXA1	404729	H.38	6KGP43010X4XXXXA1	402925	H.38
6KFP23010X4XXXXA1		H.55	6KFP43450X4XXCA1		H.55	6KGP23005X9XBXA1		H.33	6KGP43010X9XBXA1	403122	H.33
6KFP23010X9XXXXA1	404689	H.53	6KFP43450X8XXCA1	403876	H.53	6KGP23005X9XXXXA1	404675	H.34	6KGP43010X9XXXXA1	402746	H.34
6KFP23015X2XXXXA1	404703	H.54	6KFP43500X2XXCA1	403908	H.54	6KGP23007X2XBXA1		H.35	6KGP43015X2XBXA1	403163	H.35
6KFP23015X4XXXXA1		H.55	6KFP43500X4XXCA1		H.55	6KGP23007X2XXXXA1	404716	H.36	6KGP43015X2XXXXA1	402895	H.36
6KFP23015X9XXXXA1	404690	H.53	6KFP43500X8XXCA1	403877	H.53	6KGP23007X4XBXA1		H.37	6KGP43015X4XBXA1	403194	H.37
6KFP23020X2XXXXA1	404704	H.54	6KFP43550X2XXCA1	403909	H.54	6KGP23007X4XXXXA1	404730	H.38	6KGP43015X4XXXXA1	402926	H.38
6KFP23020X4XXXXA1		H.55	6KFP43550X4XXCA1		H.55	6KGP23007X9XBXA1		H.33	6KGP43015X9XBXA1	403123	H.33
6KFP23020X9XXXXA1	404691	H.53	6KFP43550X8XXCA1	403878	H.53	6KGP23007X9XXXXA1	404676	H.34	6KGP43015X9XXXXA1	402747	H.34
6KFP23025X2XXXXA1	404705	H.54	6KFP43600X2XXCA1	403910	H.54	6KGP23010X2XBXA1		H.35	6KGP43020X2XBXA1	403164	H.35
6KFP23025X4XXXXA1		H.55	6KFP43600X4XXCA1		H.55	6KGP23010X2XXXXA1	404717	H.36	6KGP43020X2XXXXA1	402896	H.36
6KFP23025X9XXXXA1	404692	H.53	6KFP43600X8XXCA1	403879	H.53	6KGP23010X4XBXA1		H.37	6KGP43020X4XBXA1	403195	H.37
6KFP23030X2XXXXA1	404706	H.54	6KFP43650X1XXCA1	403880	H.53	6KGP23010X4XXXXA1	404731	H.38	6KGP43020X4XXXXA1	402927	H.38
6KFP23030X4XXXXA1		H.55	6KFP43650X2XXCA1	403911	H.54	6KGP23010X9XBXA1		H.33	6KGP43020X9XBXA1	403124	H.33
6KFP23030X9XXXXA1	404693	H.53	6KFP43650X4XXCA1		H.55	6KGP23010X9XXXXA1	404677	H.34	6KGP43020X9XXXXA1	402748	H.34
6KFP23040X2XXXXA1	404707	H.54	6KFP43750X1XXCA1	403881	H.53	6KGP23015X2XBXA1		H.35	6KGP43025X2XBXA1	403165	H.35
6KFP23040X4XXXXA1		H.55	6KFP43750X2XXCA1	403912	H.54	6KGP23015X2XXXXA1	404718	H.36	6KGP43025X2XXXXA1	402897	H.36
6KFP23040X9XXXXA1	404694	H.53	6KFP43750X4XXCA1		H.55	6KGP23015X4XBXA1		H.37	6KGP43025X4XBXA1	403196	H.37
6KFP23050X2XXXXA1	404708	H.54	6KFP43900X1XXCA1	403882	H.53	6KGP23015X4XXXXA1	404732	H.38	6KGP43025X4XXXXA1	402928	H.38
6KFP23050X4XXXXA1		H.55	6KFP43900X2XXCA1	403913	H.54	6KGP23015X9XBXA1		H.33	6KGP43025X9XBXA1	403125	H.33
6KFP23050X9XXXXA1	404695	H.53	6KFP43900X4XXCA1		H.55	6KGP23015X9XXXXA1	404678	H.34	6KGP43025X9XXXXA1	402765	H.34
6KFP23060X2XXXXA1	404709	H.54	6KFP63015X1XXCA1		H.53	6KGP23020X2XBXA1		H.35	6KGP43030X2XBXA1	403166	H.35
6KFP23060X4XXXXA1		H.55	6KFP63015X2XXCA1		H.54	6KGP23020X2XXXXA1	404719	H.36	6KGP43030X2XXXXA1	402898	H.36
6KFP23060X9XXXXA1	404696	H.53	6KFP63020X1XXCA1		H.53	6KGP23020X4XBXA1		H.37	6KGP43030X4XBXA1	403197	H.37
6KFP43001											

Cat. no	Ref. no.	Page	Cat. no	Ref. no.	Page	Cat. no	Ref. no.	Page	Cat. no	Ref. no.	Page
6KGP43050X2XXXA1	402900	H.36	6KGP63020X2XXXA1	403582	H.36	6KLP21001X9A1	404776	H.25	BEKH	104763	A.65
6KGP43050X4XBXA1	403199	H.37	6KGP63025X1XBXA1	403644	H.33	6KLP21002X9A1	404777	H.25	BEKV	104764	A.65
6KGP43050X4XXXA1	402931	H.38	6KGP63025X1XXXA1	403547	H.34	6KLP21003X9A1	404778	H.25	BEKVA 1	104785	A.65
6KGP43050X9XBXA1	403128	H.33	6KGP63025X2XBXA1	403682	H.35	6KLP21F25X9A1	404774	H.25	BEKVS 1	104786	A.65
6KGP43050X9XXXA1	402768	H.34	6KGP63030X1XBXA1	403583	H.36	6KLP21F50X9A1	404775	H.25	BELA	104723	B.16
6KGP43060X2XBXA1	403169	H.35	6KGP63030X1XXXA1	403548	H.34	6KLP23001X9A1	404781	H.25	BELA02	104724	B.16
6KGP43060X2XXXA1	402901	H.36	6KGP63030X2XBXA1	403683	H.35	6KLP23002X9A1	404782	H.25	BETL02C	113602	B.16
6KGP43060X4XBXA1	403200	H.37	6KGP63030X2XXXA1	403584	H.36	6KLP23003X9A1	404783	H.25	BETL02D	113604	B.16
6KGP43060X4XXXA1	402932	H.38	6KGP63040X1XBXA1	403646	H.33	6KLP23005X9A1	404784	H.25	BETL45C	113603	B.16
6KGP43060X9XBXA1	403129	H.33	6KGP63040X1XXXA1	403549	H.34	6KLP23F33X9A1	404779	H.25	BETL45D	113605	B.16
6KGP43060X9XXXA1	402769	H.34	6KGP63040X2XBXA1	403684	H.35	6KLP23F50X9A1	404780	H.25	BMLF	104800	A.59
6KGP43075X2XBXA1	403170	H.35	6KGP63040X2XXXA1	403585	H.36	6KLP43001X9A1	404787	H.25	BNL	104797	A.59
6KGP43075X2XXXA1	402902	H.36	6KGP63050X1XBXA1	403550	H.34	6KLP43002X9A1	404788	H.25	BRLL02	106622	B.15
6KGP43075X4XBXA1	403201	H.37	6KGP63050X1XXXA1	403585	H.35	6KLP43003X9A1	404789	H.25	BRLL11	104705	B.15
6KGP43075X4XXXA1	402933	H.38	6KGP63050X2XBXA1	403685	H.35	6KLP43005X9A1	404790	H.25	BRLL20	104704	B.15
6KGP43075X9XBXA1	403130	H.33	6KGP63050X2XXXA1	403586	H.36	6KLP43007X9A1	404791	H.25	BSLDZ	104719	B.16
6KGP43075X9XXXA1	402857	H.34	6KGP63060X1XBXA1	403648	H.33	6KLP43010X9A1	404792	H.25	BSLR2G	104713	B.16
6KGP43100X2XBXA1	403171	H.35	6KGP63060X1XXXA1	403551	H.34	6KLP43015X9A1	404793	H.25	BSLR2K	104714	B.16
6KGP43100X2XXXA1	402903	H.36	6KGP63060X2XBXA1	403686	H.35	6KLP43020X9A1	404794	H.25	BSLR2R	104715	B.16
6KGP43100X4XBXA1	403202	H.37	6KGP63060X2XXXA1	403587	H.36	6KLP43025X9A1	404795	H.25	BSLR3G	104716	A.58
6KGP43100X4XXXA1	402934	H.38	6KGP63075X1XBXA1	403649	H.33	6KLP43030X9A1	404795	H.25	BSLR3K	104717	A.58
6KGP43100X9XBXA1	403131	H.33	6KGP63075X1XXXA1	403552	H.34	6KLP43F50X9A1	404785	H.25	BSLR3R	104718	A.58
6KGP43100X9XXXA1	402863	H.34	6KGP63075X2XBXA1	403687	H.35	ACRP10A2H	168512	H.13	BSLV3G	104720	B.16
6KGP43125X2XBXA1	403172	H.35	6KGP63075X2XXXA1	403588	H.36	ACRP115A0H18	168521	H.13	BSLV3K	104721	B.16
6KGP43125X2XXXA1	403332	H.36	6KGP63100X1XBXA1	403650	H.33	ACRP12A0H84	168498	H.13	BSLV3R	104722	B.16
6KGP43125X8XBXA1	403132	H.33	6KGP63100X1XXXA1	403553	H.34	ACRP12A2H5	168492	H.4	BSLV3U	110836	B.16
6KGP43125X8XXXA1	402864	H.34	6KGP63100X2XBXA1	403688	H.35	ACRP14A1H4	168513	H.13	BTLF30C	104709	B.15
6KGP43150X2XBXA1	403173	H.35	6KGP63100X2XXXA1	403589	H.36	ACRP160A0H14	168522	H.13	BTLF30D	104711	B.15
6KGP43150X2XXXA1	403333	H.36	6KGP63125X2XBXA1	403689	H.35	ACRP18A0H56	168499	H.13	BTLF60C	104710	B.15
6KGP43150X4XBXA1	403133	H.33	6KGP63125X2XXXA1	403590	H.36	ACRP18A1H1	168514	H.13	BTLF60D	104712	B.15
6KGP43150X8XBXA1	403133	H.33	6KGP63125X8XBXA1	403554	H.34	ACRP18A1H3	168493	H.4	BTLFX	113001	B.15
6KGP43150X8XXXA1	402865	H.34	6KGP63150X2XBXA1	403690	H.35	ACRP22A0H84	168494	H.4	BTRF30C	108903	B.15
6KGP43150X8XXXA1	403145	H.33	6KGP63150X2XXXA1	403591	H.36	ACRP27A0H37	168500	H.13	BTRF60C	108904	B.15
6KGP431K0X1XBXA1	402877	H.34	6KGP63150X8XBXA1	403652	H.33	ACRP27A0H75	168515	H.13	BTRF60D	108906	B.15
6KGP431K0X1XXXA1	403185	H.35	6KGP63150X8XXXA1	403555	H.34	ACRP35A0H27	168501	H.13	C...		
6KGP431K0X2XBXA1	402917	H.36	6KGP631K0X1XBXA1	403663	H.33	ACRP35A0H58	168517	H.13	C04255		A.63
6KGP431K0X2XXXA1	403146	H.33	6KGP631K0X1XXXA1	403566	H.34	ACRP38A0H58	168517	H.13	C08998		A.63
6KGP431K2X1XBXA1	402878	H.34	6KGP631K0X2XBXA1	403701	H.35	ACRP38A0H58	168517	H.13	C09120		A.63
6KGP431K2X1XXXA1	402878	H.34	6KGP631K2X2XBXA1	403602	H.36	ACRP3A7H0	168490	H.4	C09476	104766	A.65
6KGP431K2X2XBXA1	403186	H.35	6KGP631K2X2XXXA1	403601	H.36	ACRP3A8H1	168509	H.4	C09479	204800	A.65
6KGP431K2X2XXXA1	402918	H.36	6KGP631K1X1XBXA1	403664	H.33	ACRP45A0H45	168518	H.13	C12168		A.63
6KGP43200X2XBXA1	403174	H.35	6KGP631K1X1XXXA1	403567	H.34	ACRP4A2H5	168495	H.13	CK07BA41		A.64
6KGP43200X2XXXA1	403334	H.36	6KGP631K1X2XBXA1	403702	H.35	ACRP4A5H1	168510	H.4	CK07BA411		A.64
6KGP43200X8XBXA1	403134	H.33	6KGP631K1X2XXXA1	403603	H.36	ACRP6A2H5	168496	H.4	CK07BE411		A.64
6KGP43200X8XXXA1	402866	H.34	6KGP631K2X1XBXA1	403665	H.33	ACRP6A3H4	168511	H.4	CK08BA411		A.64
6KGP43250X2XBXA1	403175	H.35	6KGP631K2X1XXXA1	403568	H.34	ACRP70A0H29	168519	H.13	CK08BE411		A.64
6KGP43250X2XXXA1	403335	H.36	6KGP631K2X2XBXA1	403703	H.35	ACRP90A0H22	168520	H.13	CK08CA311		A.63
6KGP43250X4XBXA1	403135	H.33	6KGP631K2X2XXXA1	403604	H.36	ACRP9A1H3	168497	H.4	CK08CE311		A.63
6KGP43250X8XBXA1	403135	H.33	6KGP631K3X1XBXA1	403666	H.33	BA15D1155	222351	F.65	CK09BE311		A.63
6KGP43250X8XXXA1	402867	H.34	6KGP631K3X1XXXA1	403569	H.34	BA15D115L	222337	F.65	CK10CE311		A.63
6KGP43300X2XBXA1	403176	H.35	6KGP631K3X2XBXA1	403704	H.35	BA15D115L	222341	F.65	CK11CE311		A.63
6KGP43300X2XXXA1	403336	H.36	6KGP631K3X2XXXA1	403605	H.36	BA15D115LG	222338	F.65	CK11CE411		A.64
6KGP43300X8XBXA1	403136	H.33	6KGP631K6X1XBXA1	404738	H.33	BA15D115LL	222340	F.65	CK12BE311		A.63
6KGP43300X8XXXA1	402868	H.34	6KGP631K6X1XXXA1	404739	H.34	BA15D115LR	222336	F.65	CK12BE411		A.64
6KGP43350X2XBXA1	403177	H.35	6KGP631K6X2XBXA1	404740	H.35	BA15D115LV	222339	F.65	CK13BA311		A.63
6KGP43350X2XXXA1	402909	H.36	6KGP63200X2XBXA1	403691	H.35	BA15D125	222348	F.65	CK75CA311		A.63
6KGP43350X8XBXA1	403137	H.33	6KGP63200X2XXXA1	403592	H.36	BA15D2305	222352	F.65	CK75CE311		A.63
6KGP43350X8XXXA1	402869	H.34	6KGP63200X8XBXA1	403556	H.34	BA15D230LA	222343	F.65	CK85BA311		A.63
6KGP43450X2XBXA1	402910	H.36	6KGP63250X2XBXA1	403692	H.35	BA15D230LB	222347	F.65	CK85BE311		A.63
6KGP43450X2XXXA1	403138	H.33	6KGP63250X2XXXA1	403593	H.36	BA15D230LG	222344	F.65	CK95BE311		A.63
6KGP43450X8XBXA1	403138	H.33	6KGP63250X8XBXA1	403654	H.33	BA15D230LL	222346	F.65	CK95BE411		A.64
6KGP43450X8XXXA1	402870	H.34	6KGP63300X2XBXA1	403557	H.34	BA15D230LL	222346	F.65	CLO0A301R		A.54
6KGP43500X2XBXA1	403179	H.35	6KGP63300X2XXXA1	403693	H.35	BA15D230LR	222342	F.65	CLO0A301T		A.53
6KGP43500X2XXXA1	402911	H.36	6KGP63300X8XBXA1	403594	H.36	BA15D230LV	222345	F.65	CLO0A310R		A.54
6KGP43500X8XBXA1	403139	H.33	6KGP63300X8XXXA1	403655	H.33	BA15D245	222349	F.65	CLO0A310T		A.53
6KGP43500X8XXXA1	402871	H.34	6KGP63300X9XBXA1	403558	H.34	BA15D24LA	222331	F.65	CLO0D301R		A.54
6KGP43550X2XBXA1	403180	H.35	6KGP63300X9XXXA1	403694	H.35	BA15D24LB	222335	F.65	CLO0D301T		A.53
6KGP43550X2XXXA1	402912	H.36	6KGP63350X2XBXA1	403595	H.36	BA15D24LG	222332	F.65	CLO0D310R		A.54
6KGP43550X8XBXA1	403140	H.33	6KGP63350X2XXXA1	403593	H.36	BA15D24LL	222334	F.65	CLO0D310T		A.53
6KGP43550X8XXXA1	402872	H.34	6KGP63350X8XBXA1	403654	H.33	BA15D24LR	222330	F.65	CLO1A301R		A.54
6KGP43600X1XBXA1	403141	H.33	6KGP63350X8XXXA1	403559	H.34	BA15D24LV	222333	F.65	CLO1A301T		A.53
6KGP43600X1XXXA1	402873	H.34	6KGP63400X2XBXA1	403695	H.35	BA15D305	222350	F.65	CLO1A310R		A.54
6KGP43600X2XBXA1	403181	H.35	6KGP63400X2XXXA1	403596	H.36	BA9S122	187852	F.31	CLO1A310T		A.53
6KGP43600X2XXXA1	402913	H.36	6KGP63400X8XBXA1	403657	H.33	BA9S130	187857	F.31	CLO1A400R		A.56
6KGP43650X1XBXA1	403142	H.33	6KGP63400X8XXXA1	403560	H.34	BA9S130LED	187190	F.31	CLO1A400T		A.55
6KGP43650X1XXXA1	402874	H.34	6KGP63500X2XBXA1	403696	H.35	BA9S220	187868	F.31	CLO1A400T		A.55
6KGP43650X2XBXA1	403182	H.35	6KGP63500X2XXXA1	403597	H.36	BA9S242	187853	F.31	CLO1A800R		A.56
6KGP43650X2XXXA1	402914	H.36	6KGP63500X8XBXA1	403658	H.33	BA9S30	187854	F.31	CLO1A800T		A.55
6KGP43700X1XBXA1	402875	H.34	6KGP63500X8XXXA1	403561	H.34	BA9S48	187855	F.31	CLO1D301R		A.54
6KGP43700X1XXXA1	403183	H.35	6KGP63550X2XBXA1	403697	H.35	BA9S6012	187856	F.31	CLO1D301T		A.53
6KGP43700X2XBXA1	402915	H.36	6KGP63550X2XXXA1	403598	H.36	BA9S606	187850	F.31	CLO1D310R		A.54
6KGP43700X2XXXA1	403144	H.33	6KGP63550X8XBXA1	403659	H.33	BA9S60LED	187191	F.31	CLO1D310T		A.53
6KGP43900X1XBXA1	402876	H.34	6KGP63550X8XXXA1	403562	H.34	BA9S615	187851	F.31	CLO1D400R		A.56
6KGP43900X1XXXA1	403184	H.35	6KGP63550X9XBXA1	403698	H.35	BA9S110	187860	F.31	CLO1D400T		A.55
6KGP43900X2XBXA1	403184	H.35	6KGP63550X9XXXA1	403599	H.36	BA9S120	187861	F.31	CLO1D800R		A.56
6KGP43900X2XXXA1	402916	H.36	6KGP63650X2XBXA1	403660	H.33	BCLF01	104701	B.15	CLO1D800T		A.55
6KGP43F00X2XBXA1	403156	H.35	6KGP63650X2XXXA1	403563	H.34	BCLF01G	104703	B.15	CLO2A301R		A.54
6KGP43F00X4XBXA1	402888	H.36	6KGP63650X8XBXA1	403699	H.35	BCLF10	104700	B.15	CLO2A301T		A.53
6KGP43F00X4XXXA1	403187	H.37	6KGP63750X2XBXA1	403600	H.36	BCLF10G	104702	B.15	CLO2A310R		A.54
6KGP43F00X9XBXA1	402										

Cat. no	Ref. no.	Page	Cat. no	Ref. no.	Page	Cat. no	Ref. no.	Page	Cat. no	Ref. no.	Page
CL02D301R		A.54	CL45D300R		A.54	EC09A311B208	267007	A.6	EC12D400B230W	267239	A.7
CL02D301T		A.53	CM1CA5F	105200	A.65	EC09A311B230	267008	A.6	EC12D400B250W	267240	A.7
CL02D310R		A.54	CSCN12A302		A.145	EC09A311B240	267009	A.6	EC12D400B440W	267241	A.7
CL02D310T		A.53	CSCN12A311		A.145	EC09A311B400	267010	A.6	EC12DB00B012W	267347	A.8
CL02D400R		A.56	CSCN12A320		A.145	EC09A311B440	267011	A.6	EC12DB00B024L	267358	A.8
CL02D400T		A.55	CSCN16A302		A.145	EC09A311B480	267012	A.6	EC12DB00B024W	267348	A.8
CL02DB00R		A.56	CSCN16A311		A.145	EC09A311B500	267013	A.6	EC12DB00B036W	267349	A.8
CL02DB00T		A.55	CSCN16A320		A.145	EC09A311B575	269075	A.6	EC12DB00B048L	267359	A.8
CL03A301M		A.53	CSCN20A301		A.145	EC09A311B600	267014	A.6	EC12DB00B048W	267350	A.8
CL03A301R		A.54	CSCN20A310		A.145	EC09D311B012W	267085	A.6	EC12DB00B060W	267351	A.8
CL03A310M		A.53	CSCN20A312		A.145	EC09D311B024L	267096	A.6	EC12DB00B072W	267352	A.8
CL03A310R		A.54	CSCN20A321		A.145	EC09D311B024W	267086	A.6	EC12DB00B110L	267360	A.8
CL03A400M		A.55	CSCN25A301		A.145	EC09D311B036W	267087	A.6	EC12DB00B110W	267353	A.8
CL03A400R		A.56	CSCN25A310		A.145	EC09D311B048L	267097	A.6	EC12DB00B125W	267354	A.8
CL03A800M		A.55	CSCN25A312		A.145	EC09D311B048W	267088	A.6	EC12DB00B230L	267361	A.8
CL03A800R		A.56	CSCN25A321		A.145	EC09D311B060W	267089	A.6	EC12DB00B230W	267355	A.8
CL03D301M		A.53	CSCN30A301		A.145	EC09D311B072W	267090	A.6	EC12DB00B250W	267356	A.8
CL03D301R		A.54	CSCN30A310		A.145	EC09D311B110L	267098	A.6	EC12DB00B440W	267357	A.8
CL03D310M		A.53	CSCN30A312		A.145	EC09D311B110W	267091	A.6	EC18A311B012	267029	A.6
CL03D310R		A.54	CSCN30A321		A.145	EC09D311B125W	267092	A.6	EC18A311B024	267030	A.6
CL03D400M		A.55	CSCN45A301		A.145	EC09D311B230L	267099	A.6	EC18A311B042	267031	A.6
CL03D400R		A.56	CSCN45A310		A.145	EC09D311B230W	267093	A.6	EC18A311B048	267032	A.6
CL03DB00M		A.55	CSCN45A311		A.145	EC09D311B250W	267094	A.6	EC18A311B110	267033	A.6
CL03DB00R		A.56	CSCN45A312		A.145	EC09D311B440W	267095	A.6	EC18A311B120	267034	A.6
CL04A301M		A.53	CSCN45A320		A.145	EC12A311B012	267015	A.6	EC18A311B208	267035	A.6
CL04A301R		A.54	CSCN55A301		A.145	EC12A311B024	267016	A.6	EC18A311B230	267036	A.6
CL04A310M		A.53	CSCN55A310		A.145	EC12A311B042	267017	A.6	EC18A311B240	267037	A.6
CL04A310R		A.54	CSCN55A311		A.145	EC12A311B048	267018	A.6	EC18A311B400	267038	A.6
CL04A400M		A.55	CSCN55A312		A.145	EC12A311B110	267019	A.6	EC18A311B440	267039	A.6
CL04A400R		A.56	CSCN55A320		A.145	EC12A311B120	267020	A.6	EC18A311B480	267040	A.6
CL04A800M		A.55	CSCN70A301		A.145	EC12A311B208	267021	A.6	EC18A311B500	267041	A.6
CL04A800R		A.56	CSCN70A310		A.145	EC12A311B230	267022	A.6	EC18A311B575	269077	A.6
CL04D301M		A.53	CSCN70A311		A.145	EC12A311B240	267023	A.6	EC18A311B600	267042	A.6
CL04D301R		A.54	CSCN70A312		A.145	EC12A311B400	267024	A.6	EC18A400B012	267189	A.7
CL04D310M		A.53	CSCN70A320		A.145	EC12A311B440	267025	A.6	EC18A400B024	267190	A.7
CL04D310R		A.54	D...			EC12A311B480	267026	A.6	EC18A400B042	267191	A.7
CL04D400M		A.55	DB6101TBNC		H.69	EC12A311B500	267027	A.6	EC18A400B048	267192	A.7
CL04D400R		A.56	DB6102TBNC		H.69	EC12A311B575	269076	A.6	EC18A400B110	267193	A.7
CL04DB00M		A.55	DB6103TBNC		H.69	EC12A311B600	267028	A.6	EC18A400B120	267194	A.7
CL04DB00R		A.56	DB6104TBNC		H.69	EC12A400B012	267175	A.7	EC18A400B208	267195	A.7
CL05A400M		A.55	DB6105TBNC		H.69	EC12A400B024	267176	A.7	EC18A400B230	267196	A.7
CL05A400R		A.56	DB6106TBNC		H.69	EC12A400B042	267177	A.7	EC18A400B240	267197	A.7
CL05A800M		A.55	DB6107TBNC		H.69	EC12A400B048	267178	A.7	EC18A400B400	267198	A.7
CL05D400M		A.55	DB6401TBNC		H.69	EC12A400B110	267179	A.7	EC18A400B440	267199	A.7
CL05D400R		A.56	DB6402TBNC		H.69	EC12A400B120	267180	A.7	EC18A400B480	267200	A.7
CL05DB00M		A.55	DB6403TBNC		H.69	EC12A400B208	267181	A.7	EC18A400B500	267201	A.7
CL05E400M		A.55	DB6404TBNC		H.69	EC12A400B230	267182	A.7	EC18A400B575	269082	A.7
CL05E800M		A.55	DB6405TBNC		H.69	EC12A400B240	267183	A.7	EC18A400B600	267202	A.7
CL06A300M		A.53	DB6406TBNC		H.69	EC12A400B400	267184	A.7	EC18A800B012	267305	A.8
CL06A300R		A.54	DB6407TBNC		H.69	EC12A400B440	267185	A.7	EC18A800B024	267306	A.8
CL06D300M		A.53	DCR12A1H7	168390	H.13	EC12A400B480	267186	A.7	EC18A800B042	267307	A.8
CL06D300R		A.54	DCR18A1H0	168391	H.13	EC12A400B500	267187	A.7	EC18A800B048	267308	A.8
CL06E300M		A.53	DCR3A15H2	168392	H.13	EC12A400B575	269081	A.7	EC18A800B110	267309	A.8
CL07A300M		A.53	DCR4A5H7	168387	H.13	EC12A400B600	267188	A.7	EC18A800B120	267310	A.8
CL07A300R		A.54	DCR4A9H2	168393	H.13	EC12A800B012	267291	A.8	EC18A800B208	267311	A.8
CL07A400M		A.55	DCR6A3H9	168388	H.13	EC12A800B024	267292	A.8	EC18A800B230	267312	A.8
CL07A400R		A.56	DCR6A6H8	168394	H.13	EC12A800B042	267293	A.8	EC18A800B240	267313	A.8
CL07AB00M		A.55	DCR9A2H4	168389	H.13	EC12A800B048	267294	A.8	EC18A800B400	267314	A.8
CL07D300M		A.53	DCR9A4H0	168395	H.13	EC12A800B110	267295	A.8	EC18A800B440	267315	A.8
CL07D300R		A.54	DCRP18A2H9	168555	H.13	EC12A800B120	267296	A.8	EC18A800B480	267316	A.8
CL07D400M		A.55	DCRP25A2H1	168556	H.13	EC12A800B208	267297	A.8	EC18A800B500	267317	A.8
CL07D400R		A.56	DCRP32A0H78	168542	H.13	EC12A800B230	267298	A.8	EC18A800B575	269116	A.8
CL07DB00M		A.55	DCRP32A1H6	168557	H.13	EC12A800B240	267299	A.8	EC18A800B600	267318	A.8
CL07E300M		A.53	DCRP45A0H55	168543	H.13	EC12A800B400	267300	A.8	EC18D311B012W	267115	A.6
CL07E400M		A.55	DEPLTACL1P1	404804	H.26	EC12A800B440	267301	A.8	EC18D311B024L	267126	A.6
CL07E800M		A.55	DEPLTACL1P2	404805	H.26	EC12A800B480	267302	A.8	EC18D311B024W	267116	A.6
CL08A300M		A.53	DEPLTACL1P3	404803	H.26	EC12A800B500	267303	A.8	EC18D311B036W	267117	A.6
CL08A300R		A.54	DINIL 02E ENU	123656	G.4	EC12A800B575	269115	A.8	EC18D311B048L	267127	A.6
CL08A800M		A.55	E...			EC12A800B600	267304	A.8	EC18D311B048W	267118	A.6
CL08D300M		A.53	EA07A301024	248005	A.43	EC12D311B012W	267100	A.6	EC18D311B060W	267119	A.6
CL08D300R		A.54	EA07A3011230	248003	A.43	EC12D311B024L	267111	A.6	EC18D311B072W	267120	A.6
CL08DB00M		A.55	EA07A301S024	247991	A.43	EC12D311B024W	267101	A.6	EC18D311B110L	267128	A.6
CL08E300M		A.53	EA07A301S048	247993	A.43	EC12D311B036W	267102	A.6	EC18D311B110W	267121	A.6
CL08E800M		A.55	EA07A301S110	247995	A.43	EC12D311B048L	267112	A.6	EC18D311B125W	267122	A.6
CL09A300M		A.53	EA07A301S230	247997	A.43	EC12D311B048W	267103	A.6	EC18D311B230L	267129	A.6
CL09A300R		A.54	EA07A310I024	248004	A.43	EC12D311B060W	267104	A.6	EC18D311B230W	267123	A.6
CL09A400M		A.55	EA07A310I230	248002	A.43	EC12D311B072W	267105	A.6	EC18D311B250W	267124	A.6
CL09A400R		A.56	EA07A310S024	247990	A.43	EC12D311B110L	267113	A.6	EC18D311B440W	267125	A.6
CL09D300M		A.53	EA07A310S048	247992	A.43	EC12D311B110W	267106	A.6	EC18D400B012W	267246	A.7
CL09D300R		A.54	EA07A310S110	247994	A.43	EC12D311B125W	267107	A.6	EC18D400B024L	267257	A.7
CL09D400M		A.55	EA07A310S230	247996	A.43	EC12D311B230L	267114	A.6	EC18D400B024W	267247	A.7
CL09D400R		A.56	EA07D301I048	248007	A.43	EC12D311B230W	267108	A.6	EC18D400B036W	267248	A.7
CL09E300M		A.53	EA07D301I110	248009	A.43	EC12D311B250W	267109	A.6	EC18D400B048L	267258	A.7
CL09E400M		A.55	EA07D301S024	247999	A.43	EC12D311B440W	267110	A.6	EC18D400B048W	267249	A.7
CL10A300M		A.53	EA07D301S110	248001	A.43	EC12D400B012W	267231	A.7	EC18D400B060W	267250	A.7
CL10A300R		A.54	EA07D310I048	248006	A.43	EC12D400B024L	267242	A.7	EC18D400B072W	267251	A.7
CL10D300M		A.53	EA07D310I110	248008	A.43	EC12D400B024W	267232	A.7	EC18D400B110L	267259	A.7
CL10D300R		A.54	EA07D310S024	247998	A.43	EC12D400B036W	267233	A.7	EC18D400B110W	267252	A.7
CL10E300M		A.53	EA07D310S110	248000	A.43	EC12D400B048L	267243	A.7	EC18D400B125W	267253	A.7
CL25A300R		A.54	EAT 260	100548	B.12	EC12D400B048W	267234	A.7	EC18D400B230L	267260	A.7
CL25A300T		A.53	EC09A311B012	267001	A.6	EC12D400B060W	267235	A.7	EC18D400B230W	267254	A.7
CL25D300R		A.54	EC09A311B024	267002	A.6	EC12D400B072W	267236	A.7	EC18D400B250W	267255	A.7
CL25D300T		A.53	EC09A311B0								

Cat. no	Ref. no.	Page	Cat. no	Ref. no.	Page	Cat. no	Ref. no.	Page	Cat. no	Ref. no.	Page
EC18DB00B036W	267364	A.8	EC25DB00B250W	267386	A.8	EC40A300B208	267077	A.6	ECACA440B440	268150	A.9
EC18DB00B048L	267374	A.8	EC25DB00B440W	267387	A.8	EC40A300B230	267078	A.6	ECACA440B480	268151	A.9
EC18DB00B048W	267365	A.8	EC32A300B012	267057	A.6	EC40A300B240	267079	A.6	ECACA440B500	268152	A.9
EC18DB00B060W	267366	A.8	EC32A300B024	267058	A.6	EC40A300B400	267080	A.6	ECACA440B575	268673	A.9
EC18DB00B072W	267367	A.8	EC32A300B042	267059	A.6	EC40A300B440	267081	A.6	ECACA440B600	268153	A.9
EC18DB00B110L	267375	A.8	EC32A300B048	267060	A.6	EC40A300B480	267082	A.6	ECACD404B012W	268270	A.9
EC18DB00B110W	267368	A.8	EC32A300B110	267061	A.6	EC40A300B500	267083	A.6	ECACD404B024L	268281	A.9
EC18DB00B125W	267369	A.8	EC32A300B120	267062	A.6	EC40A300B575	269080	A.6	ECACD404B024W	268271	A.9
EC18DB00B230L	267376	A.8	EC32A300B208	267063	A.6	EC40A300B600	267084	A.6	ECACD404B036W	268272	A.9
EC18DB00B230W	267370	A.8	EC32A300B230	267064	A.6	EC40D300B012W	267160	A.6	ECACD404B048L	268282	A.9
EC18DB00B250W	267371	A.8	EC32A300B240	267065	A.6	EC40D300B024L	267171	A.6	ECACD404B048W	268273	A.9
EC18DB00B440W	267372	A.8	EC32A300B400	267066	A.6	EC40D300B024W	267161	A.6	ECACD404B060W	268274	A.9
EC25A311B012	267043	A.6	EC32A300B440	267067	A.6	EC40D300B036W	267162	A.6	ECACD404B072W	268275	A.9
EC25A311B024	267044	A.6	EC32A300B480	267068	A.6	EC40D300B048L	267172	A.6	ECACD404B110L	268283	A.9
EC25A311B042	267045	A.6	EC32A300B500	267069	A.6	EC40D300B048W	267163	A.6	ECACD404B110W	268276	A.9
EC25A311B048	267046	A.6	EC32A300B575	269079	A.6	EC40D300B060W	267164	A.6	ECACD404B125W	268277	A.9
EC25A311B110	267047	A.6	EC32A300B600	267070	A.6	EC40D300B072W	267165	A.6	ECACD404B230L	268284	A.9
EC25A311B120	267048	A.6	EC32A400B012	267217	A.7	EC40D300B110L	267173	A.6	ECACD404B230W	268278	A.9
EC25A311B208	267049	A.6	EC32A400B024	267218	A.7	EC40D300B110W	267166	A.6	ECACD404B250W	268279	A.9
EC25A311B230	267050	A.6	EC32A400B042	267219	A.7	EC40D300B125W	267167	A.6	ECACD404B440W	268280	A.9
EC25A311B240	267051	A.6	EC32A400B048	267220	A.7	EC40D300B230L	267174	A.6	ECACD413B012W	268400	A.9
EC25A311B400	267052	A.6	EC32A400B110	267221	A.7	EC40D300B230W	267168	A.6	ECACD413B024L	268411	A.9
EC25A311B440	267053	A.6	EC32A400B120	267222	A.7	EC40D300B250W	267169	A.6	ECACD413B024W	268401	A.9
EC25A311B480	267054	A.6	EC32A400B208	267223	A.7	EC40D300B440W	267170	A.6	ECACD413B036W	268402	A.9
EC25A311B500	267055	A.6	EC32A400B230	267224	A.7	EC4PP1B	268944	A.13	ECACD413B048L	268412	A.9
EC25A311B575	269078	A.6	EC32A400B240	267225	A.7	EC4PP2B	268947	A.13	ECACD413B048W	268403	A.9
EC25A311B600	267056	A.6	EC32A400B400	267226	A.7	ECACA404B012	268196	A.9	ECACD413B060W	268404	A.9
EC25A400B012	267203	A.7	EC32A400B440	267227	A.7	ECACA404B024	268197	A.9	ECACD413B072W	268405	A.9
EC25A400B024	267204	A.7	EC32A400B480	267228	A.7	ECACA404B042	268198	A.9	ECACD413B110L	268413	A.9
EC25A400B042	267205	A.7	EC32A400B500	267229	A.7	ECACA404B048	268199	A.9	ECACD413B110W	268406	A.9
EC25A400B048	267206	A.7	EC32A400B575	269084	A.7	ECACA404B110	268200	A.9	ECACD413B125W	268407	A.9
EC25A400B110	267207	A.7	EC32A400B600	267230	A.7	ECACA404B120	268201	A.9	ECACD413B230L	268414	A.9
EC25A400B120	267208	A.7	EC32A800B012	267333	A.8	ECACA404B208	268202	A.9	ECACD413B230W	268408	A.9
EC25A400B208	267209	A.7	EC32A800B024	267334	A.8	ECACA404B230	268203	A.9	ECACD413B250W	268409	A.9
EC25A400B230	267210	A.7	EC32A800B042	267335	A.8	ECACA404B240	268204	A.9	ECACD413B440W	268410	A.9
EC25A400B240	267211	A.7	EC32A800B048	267336	A.8	ECACA404B400	268205	A.9	ECACD422B012W	268240	A.9
EC25A400B400	267212	A.7	EC32A800B110	267337	A.8	ECACA404B440	268206	A.9	ECACD422B024L	268251	A.9
EC25A400B440	267213	A.7	EC32A800B120	267338	A.8	ECACA404B480	268207	A.9	ECACD422B024W	268241	A.9
EC25A400B480	267214	A.7	EC32A800B208	267339	A.8	ECACA404B500	268208	A.9	ECACD422B036W	268242	A.9
EC25A400B500	267215	A.7	EC32A800B230	267340	A.8	ECACA404B575	268677	A.9	ECACD422B048L	268252	A.9
EC25A400B575	269083	A.7	EC32A800B240	267341	A.8	ECACA404B600	268209	A.9	ECACD422B048W	268243	A.9
EC25A400B600	267216	A.7	EC32A800B400	267342	A.8	ECACA413B012	268182	A.9	ECACD422B060W	268244	A.9
EC25AB00B012	267319	A.8	EC32A800B440	267343	A.8	ECACA413B024	268183	A.9	ECACD422B072W	268245	A.9
EC25AB00B024	267320	A.8	EC32A800B480	267344	A.8	ECACA413B042	268184	A.9	ECACD422B110L	268253	A.9
EC25AB00B042	267321	A.8	EC32A800B500	267345	A.8	ECACA413B048	268185	A.9	ECACD422B110W	268246	A.9
EC25AB00B048	267322	A.8	EC32A800B575	269118	A.8	ECACA413B110	268186	A.9	ECACD422B125W	268247	A.9
EC25AB00B110	267323	A.8	EC32A800B600	267346	A.8	ECACA413B120	268187	A.9	ECACD422B230L	268254	A.9
EC25AB00B120	267324	A.8	EC32D300B012W	267145	A.6	ECACA413B208	268188	A.9	ECACD422B230W	268248	A.9
EC25AB00B208	267325	A.8	EC32D300B024L	267156	A.6	ECACA413B230	268189	A.9	ECACD422B250W	268249	A.9
EC25AB00B230	267326	A.8	EC32D300B024W	267146	A.6	ECACA413B240	268190	A.9	ECACD422B440W	268250	A.9
EC25AB00B240	267327	A.8	EC32D300B036W	267147	A.6	ECACA413B400	268191	A.9	ECACD431B012W	268225	A.9
EC25AB00B400	267328	A.8	EC32D300B048L	267157	A.6	ECACA413B440	268192	A.9	ECACD431B024L	268236	A.9
EC25AB00B440	267329	A.8	EC32D300B048W	267148	A.6	ECACA413B480	268193	A.9	ECACD431B024W	268226	A.9
EC25AB00B480	267330	A.8	EC32D300B060W	267149	A.6	ECACA413B500	268194	A.9	ECACD431B036W	268227	A.9
EC25AB00B500	267331	A.8	EC32D300B072W	267150	A.6	ECACA413B575	268676	A.9	ECACD431B048L	268237	A.9
EC25AB00B575	269117	A.8	EC32D300B110L	267158	A.6	ECACA413B600	268195	A.9	ECACD431B048W	268228	A.9
EC25AB00B600	267332	A.8	EC32D300B110W	267151	A.6	ECACA422B012	268168	A.9	ECACD431B060W	268229	A.9
EC25D311B012W	267130	A.6	EC32D300B125W	267152	A.6	ECACA422B024	268169	A.9	ECACD431B072W	268230	A.9
EC25D311B024W	267141	A.6	EC32D300B230L	267159	A.6	ECACA422B042	268170	A.9	ECACD431B110L	268238	A.9
EC25D311B024W	267131	A.6	EC32D300B230W	267153	A.6	ECACA422B048	268171	A.9	ECACD431B110W	268231	A.9
EC25D311B036W	267132	A.6	EC32D300B250W	267154	A.6	ECACA422B110	268172	A.9	ECACD431B125W	268232	A.9
EC25D311B048L	267142	A.6	EC32D300B440W	267155	A.6	ECACA422B120	268173	A.9	ECACD431B230L	268239	A.9
EC25D311B048W	267133	A.6	EC32D400B012W	267276	A.7	ECACA422B208	268174	A.9	ECACD431B230W	268233	A.9
EC25D311B060W	267134	A.6	EC32D400B024L	267287	A.7	ECACA422B230	268175	A.9	ECACD431B250W	268234	A.9
EC25D311B072W	267135	A.6	EC32D400B024W	267277	A.7	ECACA422B240	268176	A.9	ECACD431B440W	268235	A.9
EC25D311B110L	267143	A.6	EC32D400B036W	267278	A.7	ECACA422B400	268177	A.9	ECACD440B012W	268210	A.9
EC25D311B110W	267136	A.6	EC32D400B048L	267288	A.7	ECACA422B440	268178	A.9	ECACD440B024L	268221	A.9
EC25D311B125W	267137	A.6	EC32D400B048W	267279	A.7	ECACA422B480	268179	A.9	ECACD440B024W	268211	A.9
EC25D311B230L	267144	A.6	EC32D400B060W	267280	A.7	ECACA422B500	268180	A.9	ECACD440B036W	268212	A.9
EC25D311B230W	267138	A.6	EC32D400B072W	267281	A.7	ECACA422B575	268675	A.9	ECACD440B048L	268222	A.9
EC25D311B250W	267139	A.6	EC32D400B110L	267289	A.7	ECACA422B600	268181	A.9	ECACD440B048W	268213	A.9
EC25D311B440W	267140	A.6	EC32D400B110W	267282	A.7	ECACA431B012	268154	A.9	ECACD440B060W	268214	A.9
EC25D400B012W	267261	A.7	EC32D400B125W	267283	A.7	ECACA431B024	268155	A.9	ECACD440B072W	268215	A.9
EC25D400B024L	267272	A.7	EC32D400B230L	267290	A.7	ECACA431B042	268156	A.9	ECACD440B110L	268223	A.9
EC25D400B024W	267262	A.7	EC32D400B230W	267284	A.7	ECACA431B048	268157	A.9	ECACD440B110W	268216	A.9
EC25D400B036W	267263	A.7	EC32D400B250W	267285	A.7	ECACA431B110	268158	A.9	ECACD440B125W	268217	A.9
EC25D400B048L	267273	A.7	EC32D400B440W	267286	A.7	ECACA431B120	268159	A.9	ECACD440B230L	268224	A.9
EC25D400B048W	267264	A.7	EC32DB00B012W	267392	A.8	ECACA431B208	268160	A.9	ECACD440B230W	268218	A.9
EC25D400B060W	267265	A.7	EC32DB00B024W	267393	A.8	ECACA431B230	268161	A.9	ECACD440B250W	268219	A.9
EC25D400B072W	267266	A.7	EC32DB00B036W	267394	A.8	ECACA431B240	268162	A.9	ECACD440B440W	268220	A.9
EC25D400B110L	267274	A.7	EC32DB00B048W	267395	A.8	ECACA431B400	268163	A.9	ECBB1B2	268942	A.13
EC25D400B110W	267267	A.7	EC32DB00B060W	267396	A.8	ECACA431B440	268164	A.9	ECBB2B2	268945	A.13
EC25D400B125W	267268	A.7	EC32DB00B072W	267397	A.8	ECACA431B480	268165	A.9	ECBP45	268962	A.13
EC25D400B230L	267275	A.7	EC32DB00B110W	267398	A.8	ECACA431B500	268166	A.9	ECBP55	268953	A.13
EC25D400B230W	267269	A.7	EC32DB00B125W	267399	A.8	ECACA431B575	268674	A.9	ECBS60S	267406	A.13
EC25D400B250W	267270	A.7	EC32DB00B230W	267400	A.8	ECACA431B600	268167	A.9	ECBSLP	267407	A.13
EC25D400B440W	267271	A.7	EC32DB00B250W	267401	A.8	ECACA440B012	268140	A.9	ECBSLS	267405	A.13
EC25DB00B012W	267377	A.8	EC32DB00B								



Cat. no	Ref. no.	Page	Cat. no	Ref. no.	Page	Cat. no	Ref. no.	Page	Cat. no	Ref. no.	Page
ECSS1A230S	268694	A.10	ECML2DS277	269334	A.12	GLIX15HS-B	817734	J.6	GPAL01FRA	101312	C.11
ECSS1A240S	268695	A.10	ECML2DS440	269336	A.12	GLIX15KS	817706	J.7	GPAL10FRA	101311	C.11
ECSS1A400S	268696	A.10	ECPT30SC	268913	A.11	GLIX15VCC	817813	J.6	GPAPT1E	107315	C.13
ECSS1A440S	268697	A.10	ECPT30SD	268916	A.11	GLIX15VCC-B	817827	J.6	GPAPT2A	107182	C.12
ECSS1A480S	268698	A.10	ECPT60SC	268914	A.11	GLIX15VCIC	817313	J.6	GPASLRAA1	101318	C.12
ECSS1A500S	268699	A.10	ECPT60SD	268917	A.11	GLIX15VCIC-B	817327	J.6	GPASLRAA11	101194	C.12
ECSS1A575S	268984	A.10	ECRT1B10B	268996	A.14	GLIX15VIC	817213	J.6	GPASLRAAF	101319	C.12
ECSS1A600S	268700	A.10	ECRT1B10C	268997	A.14	GLIX15VIC-B	817227	J.6	GPASLRAAG	101320	C.12
ECSS1D012S	268701	A.10	ECRT1B10D	268998	A.14	GLIX15VS	817713	J.6	GPASLRAAJ	101321	C.12
ECSS1D024S	268702	A.10	ECRT1B10F	268999	A.14	GLIX15VS-B	817727	J.6	GPASLRAAM	101322	C.12
ECSS1D024SL	268712	A.10	ECRT1B10G	269000	A.14	GLIX20HCC	817821	J.6	GPASLRAAN	101323	C.12
ECSS1D036S	268703	A.10	ECRT1B10H	269001	A.14	GLIX20HCC-B	817835	J.6	GPASLRAAR	101324	C.12
ECSS1D048S	268704	A.10	ECRT1B10J	269002	A.14	GLIX20HCIC	817321	J.6	GPASLRAAA	101325	C.12
ECSS1D048SL	268713	A.10	ECRT1B10K	269003	A.14	GLIX20HCIC-B	817335	J.6	GPASLRAAW	101326	C.12
ECSS1D060S	268705	A.10	ECRT1B10L	269004	A.14	GLIX20HIC	817221	J.6	GPASLRAAY	101327	C.12
ECSS1D072S	268706	A.10	ECRT1B10M	269005	A.14	GLIX20HIC-B	817235	J.6	GPASLRADD	101328	C.12
ECSS1D110S	268707	A.10	ECRT1B10N	269006	A.14	GLIX20HS	817721	J.6	GPASLRADJ	101329	C.12
ECSS1D110SL	268714	A.10	ECRT1B10P	269007	A.14	GLIX20HS-B	817735	J.6	GPAP20CAA11	112185	C.12
ECSS1D125S	268708	A.10	ECRT1B10S	269008	A.14	GLIX20KS	817707	J.7	GPAP20CAAC	101353	C.12
ECSS1D230S	268709	A.10	ECRT1B10T	269009	A.14	GLIX20VCC	817814	J.6	GPAP20CAAD	101352	C.12
ECSS1D230SL	268715	A.10	ECRT1BS	268963	A.14	GLIX20VCC-B	817828	J.6	GPAP20CAAF	101355	C.12
ECSS1D250S	268710	A.10	ECRT2B10N	268103	A.14	GLIX20VCIC	817314	J.6	GPAP20CAAG	101354	C.12
ECSS1D440S	268711	A.10	ECRT2B10P	268104	A.14	GLIX20VCIC-B	817328	J.6	GPAP20CAAJ	101356	C.12
ECSS2A012S	268716	A.10	ECRT2B10S	268105	A.14	GLIX20VIC	817214	J.6	GPAP20CAAM	101357	C.12
ECSS2A024S	268717	A.10	ECRT2B10T	268106	A.14	GLIX20VIC-B	817228	J.6	GPAP20CAAN	101358	C.12
ECSS2A042S	268718	A.10	ECRT2B10U	268107	A.14	GLIX20VS	817714	J.6	GPAP20CAAR	101359	C.12
ECSS2A048S	268719	A.10	ECRT2B10V	268108	A.14	GLIX20VS-B	817728	J.6	GPAP20CAAA	101360	C.12
ECSS2A110S	268720	A.10	ECRT2B10W	268109	A.14	GLIX25HCC	817822	J.6	GPAP20CAAW	101361	C.12
ECSS2A120S	268721	A.10	ECRT2BS	268964	A.14	GLIX25HCC-B	817836	J.6	GPAP20CAAAY	101362	C.12
ECSS2A208S	268722	A.10	ECSUD1440	268931	A.12	GLIX25HCIC	817322	J.6	GPAP20LTA11	110360	C.12
ECSS2A230S	268723	A.10	ECSURC048	268932	A.12	GLIX25HCIC-B	817336	J.6	GPAP20LTAAC	101342	C.12
ECSS2A240S	268724	A.10	ECSURC127	268933	A.12	GLIX25SHIC	817222	J.6	GPAP20LTAAD	101341	C.12
ECSS2A400S	268725	A.10	ECSURC250	268934	A.12	GLIX25SHIC-B	817236	J.6	GPAP20LTAAG	101344	C.12
ECSS2A440S	268726	A.10	ECSURC440	268935	A.12	GLIX25HS	817722	J.6	GPAP20LTAAG	101343	C.12
ECSS2A480S	268727	A.10	ECSURC600	268936	A.12	GLIX25HS-B	817736	J.6	GPAP20LTAAJ	101345	C.12
ECSS2A500S	268728	A.10	ECSUVA048	268937	A.12	GLIX25KS	817708	J.7	GPAP20LTAAM	101346	C.12
ECSS2A575S	268985	A.10	ECSUVA127	268938	A.12	GLIX25VCC	817815	J.6	GPAP20LTAAN	101347	C.12
ECSS2A600S	268729	A.10	ECSUVA250	268939	A.12	GLIX25VCC-B	817829	J.6	GPAP20LTAAR	101348	C.12
ECSS2D012S	268730	A.10	ECSUVA440	268940	A.12	GLIX25VCIC	817315	J.6	GPAP20LTAAY	101349	C.12
ECSS2D024S	268731	A.10	ECSUVA600	268941	A.12	GLIX25VCIC-B	817329	J.6	GPAP20LTAAY	101350	C.12
ECSS2D024SL	268741	A.10	EPL	104798	A.59	GLIX25VIC	817215	J.6	GPAP20LTAAY	101351	C.12
ECSS2D036S	268732	A.10	F...			GLIX25VIC-B	817229	J.6	GPAPLRAA11	102625	C.12
ECSS2D048S	268733	A.10	FD63		A.25	GLIX25VS	817715	J.6	GPAPLRAAC	101331	C.12
ECSS2D048SL	268742	A.10	FDH36MC080GD		A.128	GLIX25VS-B	817729	J.6	GPAPLRAAD	101330	C.12
ECSS2D060S	268734	A.10	FDH36MC1 OOGD		A.128	GLIX30HCC	817823	J.6	GPAPLRAAF	101333	C.12
ECSS2D072S	268735	A.10	FEH36MC125JF		A.128	GLIX30HCC-B	817837	J.6	GPAPLRAAG	101332	C.12
ECSS2D110S	268736	A.10	FEH36MC200KF		A.128	GLIX30HCIC	817323	J.6	GPAPLRAAJ	101334	C.12
ECSS2D110SL	268743	A.10	G...			GLIX30HCIC-B	817337	J.6	GPAPLRAAM	101335	C.12
ECSS2D125S	268737	A.10	GLCB	817801	J.7	GLIX30HIC	817223	J.6	GPAPLRAAN	101336	C.12
ECSS2D230S	268738	A.10	GLCMDM	817806	J.7	GLIX30HIC-B	817237	J.6	GPAPLRAAR	101337	C.12
ECSS2D230SL	268744	A.10	GLIN03KS	817700	J.7	GLIX30HS	817723	J.6	GPAPLRAAU	101338	C.12
ECSS2D250S	268739	A.10	GLIN06KS	817701	J.7	GLIX30HS-B	817737	J.6	GPAPLRAAV	101339	C.12
ECSS2D440S	268740	A.10	GLIN10KS	817702	J.7	GLIX30KS	817709	J.7	GPAPLRAAY	101340	C.12
ECFA202S	268874	A.11	GLIN15KS	817703	J.7	GLIX30VCC	817816	J.6	GPB104A	101392	C.35
ECFA211S	268872	A.11	GLIOB	817803	J.7	GLIX30VCC-B	817830	J.6	GPB105A	101393	C.35
ECFA220S	268873	A.11	GLIX07HCC	817818	J.6	GLIX30VCIC	817316	J.6	GPB1B02A	101390	C.13
ECFA404S	268885	A.11	GLIX07HCC-B	817832	J.6	GLIX30VCIC-B	817330	J.6	GPB1B03A	101391	C.13
ECFA413S	268884	A.11	GLIX07HCIC	817318	J.6	GLIX30VIC	817216	J.6	GPB1B04A	101392	C.13
ECFA422S	268883	A.11	GLIX07HCIC-B	817332	J.6	GLIX30VIC-B	817230	J.6	GPB1B05A	101393	C.13
ECFA422SE	268886	A.11	GLIX07HIC	817218	J.6	GLIX30VS	817716	J.6	GPB1B12A	101394	C.13
ECFA431S	268882	A.11	GLIX07HIC-B	817232	J.6	GLIX30VS-B	817730	J.6	GPB1B13A	101395	C.13
ECFA440S	268881	A.11	GLIX07HS	817718	J.6	GLIX45HCC	817824	J.6	GPB1B14A	101396	C.13
ECKS1RV	268948	A.13	GLIX07HS-B	817732	J.6	GLIX45HCC-B	817838	J.6	GPB1B15A	101397	C.13
ECKS1YD	268951	A.13	GLIX07KS	817704	J.7	GLIX45HCIC	817324	J.6	GPB1B22A	101398	C.13
ECKS2RV	268950	A.13	GLIX07VCC	817811	J.6	GLIX45HCIC-B	817338	J.6	GPB1B24A	101399	C.13
ECKS2YD	268952	A.13	GLIX07VCC-B	817825	J.6	GLIX45SHIC	817224	J.6	GPB1FA	107186	C.13
ECLA202S	268901	A.11	GLIX07VCIC	817311	J.6	GLIX45SHIC-B	817238	J.6	GPB1GA	101408	C.13
ECLA211S	268900	A.11	GLIX07VCIC-B	817325	J.6	GLIX45HS	817724	J.6	GPB1GAF	101511	C.13
ECLA220S	268899	A.11	GLIX07VIC	817211	J.6	GLIX45HS-B	817738	J.6	GPB2B02A	101400	C.13
ECM1A125	268954	A.13	GLIX07VIC-B	817225	J.6	GLIX45KS	817710	J.7	GPB2B03A	101401	C.13
ECM1A132	268955	A.13	GLIX07VS	817711	J.6	GLIX45VCC	817817	J.6	GPB2B04A	101402	C.13
ECM2A140	268956	A.13	GLIX07VS-B	817725	J.6	GLIX45VCC-B	817831	J.6	GPB2B12A	101403	C.13
ECMI	268908	A.11	GLIX10HCC	817819	J.6	GLIX45VCIC	817317	J.6	GPB2B13A	101404	C.13
ECMI02S	268910	A.11	GLIX10HCC-B	817833	J.6	GLIX45VCIC-B	817331	J.6	GPB2B14A	101405	C.13
ECML1A5032	268919	A.12	GLIX10HCIC	817319	J.6	GLIX45VIC	817217	J.6	GPB2B22A	101406	C.13
ECML1A5060	268920	A.12	GLIX10HCIC-B	817333	J.6	GLIX45VIC-B	817231	J.6	GPB2B24A	101407	C.13
ECML1A5127	268921	A.12	GLIX10HIC	817219	J.6	GLIX45VS	817717	J.6	GPB2FA	107187	C.13
ECML1A5277	268922	A.12	GLIX10HIC-B	817233	J.6	GLIX45VS-B	817731	J.6	GPB2GA	101409	C.13
ECML1A5480	268923	A.12	GLIX10HS	817719	J.6	GPA1HAB	101363	C.13	GPECA	101371	C.17
ECML1A5660	268924	A.12	GLIX10HS-B	817733	J.6	GPA1HAR	101364	C.13	GPEF41A	101367	C.17
ECML1D5036	269325	A.12	GLIX10KS	817705	J.7	GPA2HAB	101502	C.13	GPEF55A	101368	C.17
ECML1D5048	269326	A.12	GLIX10VCC	817812	J.6	GPA2HAR	101503	C.13	GPELCAJ	101385	C.17
ECML1D5072	269327	A.12	GLIX10VCC-B	817826	J.6	GPAC01FBA	101304	C.11	GPELCAJ	101385	C.17
ECML1D5177	269328	A.12	GLIX10VCIC	817312	J.6	GPAC02LLA	101307	C.11	GPELCAU	101387	C.17
ECML1D5250	269329	A.12	GLIX10VCIC-B	817326	J.6	GPAC02LRA	101310	C.11	GPELCAV	101388	C.17
ECML1D5440	269330	A.12	GLIX10VIC	817212	J.6	GPAC10FBA	101303	C.11	GPELCAW	101389	C.17
ECML2A5032	268925	A.12	GLIX10VIC-B	817226	J.6	GPAC11LLA	101305	C.11	GPELGAJ	101375	C.17
ECML2A5060	268926	A.12	GLIX10VS	817712	J.6	GPAC11LRA	101308	C.11	GPELGAN	101376	C.17
ECML2A5127	268927	A.12	GLIX10VS-B	817726	J.6	GPAC20LLA	101306	C.11	GPELGAU	101377	C.17
ECML2A5277	268928	A.12	GLIX15HCC	817820	J.6	GPAC20LRA	101309	C.11	GPELGAX	101378	C.17
ECML2A5480	268929	A.12	GLIX15HCC-B	817834	J.6	GPAD0101LLA	101316	C.11	GPELGAY	101379	C.17
ECML2A5660	268930	A.12	GLIX15HCIC	817320	J.6	GPAD0110LLA	101315	C.11	GPELRAJ	101380	C.17
ECML2D5036	269331	A.12	GLIX15HCIC-B	817334	J.6	GPAD1001LLA	101314	C.11	GPELRAN	101381	C.17
ECML2D5048	269332	A.12	GLIX15HIC	817220	J.6	GPAD1010LLA	101313	C.11	GPELRAU	101382	C.17
ECML2D5072	269333	A.12	GLIX15HIC-B	817234	J.6	GPAE11LLA	10131				

Cat. no	Ref. no.	Page	Cat. no	Ref. no.	Page	Cat. no	Ref. no.	Page	Cat. no	Ref. no.	Page
GPENA	101369	C.17	GPS1MSAR	101271	C.7	KVP12U	113630	A.66	MB0ID	100470	B.9
GPPEA	101370	C.17	GPS2BHAK	101249	C.5	KVP75E	133378	A.67	MB0KD	100471	B.9
GPPEKA	101374	C.17	GPS2BHAL	107120	C.5	KVP75I	133370	A.66	MC1A301AF		A.45
GPPELA	101373	C.17	GPS2BHAM	101250	C.5	KVP75U	113627	A.66	MC1A301AI		A.45
GPPEMA	101372	C.17	GPS2BHAN	101251	C.5	KVP85E	133379	A.67	MC1A301AR		A.45
GPES41A	101365	C.17	GPS2BHP	101252	C.5	KVP85G	104770	A.66	MC1A301AT		A.45
GPES55A	101366	C.17	GPS2BHAR	101253	C.5	KVP85I	113631	A.66	MC1A310AF		A.45
GPTEUTA	107097	C.17	GPS2BHAS	101254	C.5	KVP85U	113628	A.66	MC1A310AI		A.45
GPF00C02	107098	C.15	GPS2BHAT	101255	C.5	KVP95E	113637	A.67	MC1A310AR		A.45
GPF00C04	107102	C.15	GPS2BHAU	101256	C.5	KYDACL1	404796	H.26	MC1A310AT		A.45
GPF00C08	107107	C.15	GPS2BSAK	101226	C.5				MC1A400AF		A.47
GPF00C25	107101	C.15	GPS2BSAL	107119	C.5	LB1A		B.15	MC1A400AI		A.47
GPF00C45	107106	C.15	GPS2BSAM	101227	C.5	LB1D		B.15	MC1A400AT		A.47
GPF01C02	107100	C.15	GPS2BSAN	101228	C.5	LB3A		A.53	MC1A400AF		A.47
GPF01C04	107105	C.15	GPS2BSAP	101229	C.5	LB3D		A.53	MC1A400AI		A.47
GPF10C02	107099	C.15	GPS2BSAR	101230	C.5	LB4A		A.53	MC1A400AT		A.47
GPF10C04	107103	C.15	GPS2BSAS	101231	C.5	LB4D		A.53	MC1A800AF		A.47
GPF1B1A	101418	C.15	GPS2BSAT	101232	C.5	LB4E		A.53	MC1A800AI		A.47
GPF1B4A	107163	C.15	GPS2BSAU	101233	C.5	LG0004P1B0	209344	A.59	MC1A800AT		A.47
GPF1CBA	101427	C.15	GPS2MHAK	101295	C.9	LG0004R1B0	116651	A.59	MC1C301AF		A.45
GPF1L02AA	101411	C.15	GPS2MHAL	107122	C.9	LG0004S1B0	209347	A.59	MC1C301AI		A.45
GPF1L02DA	101412	C.15	GPS2MHAM	101296	C.9	LG0006P1B0	200004	A.59	MC1C301AR		A.45
GPF1L04AA	107165	C.15	GPS2MHAN	101297	C.9	LG0006R1B0	116652	A.59	MC1C301AT		A.45
GPF1L04DA	107166	C.15	GPS2MHAP	101298	C.9	LG0006S1B0	116611	A.59	MC1C310AF		A.45
GPF1L25AA	101413	C.15	GPS2MHAR	101299	C.9	LG0404P1B0	116653	A.59	MC1C310AI		A.45
GPF1L25CT1	101512	C.15	GPS2MHAS	101300	C.9	LG0404R1B0	133264	A.59	MC1C310AR		A.45
GPF1L25DA	101414	C.15	GPS2MHAT	101301	C.9	LG0404S1B0	116996	A.59	MC1C310AT		A.45
GPF1L45CT1	101513	C.15	GPS2MHAU	101302	C.9	LG0406P1B0	116656	A.59	MC1C400AF		A.47
GPF1LMCBA	101410	C.15	GPS2MSAK	101272	C.9	LG0406R1B0	133265	A.59	MC1C400AI		A.47
GPF2B2A	101419	C.15	GPS2MSAL	107121	C.9	LG0406S1B0	116997	A.59	MC1C400AT		A.47
GPF2B3A	101420	C.15	GPS2MSAM	101273	C.9	LG2504P1B0	100885	A.59	MC1C800AF		A.47
GPF2L04AA	107190	C.15	GPS2MSAN	101274	C.9	LG2504R1B0	116226	A.59	MC1C800AI		A.47
GPF2L04DA	107191	C.15	GPS2MSAP	101275	C.9	LG2506P1B0	101095	A.59	MC1C800AT		A.47
GPF2L45AA	101415	C.15	GPS2MSAR	101276	C.9	LG2506R1B0	133611	A.59	MC1I301ATD	100573	A.46
GPF2L45DA	101416	C.15	GPS2MSAS	101277	C.9	LR1A		B.15	MC1I310ATD	100572	A.46
GPF3B5A	107253	C.15	GPS2MSAT	101278	C.9	LR1D		B.15	MC1K301ATD	100577	A.46
GPF3L09AA	107252	C.15	GPS2MSAU	101279	C.9	LR3A		A.56	MC1K310ATD	100576	A.46
GPS1BHAA	101234	C.3	GPVDA	101514	C.12	LR3D		A.56	MC2A301AI		A.45
GPS1BHAB	101235	C.3	GPVPA	101515	C.12	LR4A		A.56	MC2A301AR		A.45
GPS1BHAC	101236	C.3				LR4D		A.56	MC2A301AT		A.45
GPS1BHAD	101237	C.3	IB	201943	G.27				MC2A310AI		A.45
GPS1BHA	101238	C.3	IP	201942	G.27	MACL101AF	100563	A.49	MC2A310AR		A.45
GPS1BHAE	101239	C.3	IPAI-N211B	132170	F.69	MACL101AI	100565	A.49	MC2A310AT		A.45
GPS1BHAG	101240	C.3	IPAI-N411B	132198	F.69	MACL101AR	103556	A.49	MC2A400AT		A.47
GPS1BHAI	101241	C.3	IPAI-N422B	132213	F.69	MACL101AT	100561	A.49	MC2A800AT		A.47
GPS1BHAI	101242	C.3	IPB1-D422B	132216	F.69	MACL110AF	100562	A.49	MC2C301AI		A.45
GPS1BHAK	101243	C.3	IPB1-N211B	132172	F.69	MACL110AI	100564	A.49	MC2C301AR		A.45
GPS1BHAL	101244	C.3	IPB1-N222B	132186	F.69	MACL110AR	103555	A.49	MC2C301AT		A.45
GPS1BHAM	101245	C.3	IPB1-N411B	132201	F.69	MACL110AT	100560	A.49	MC2C310AI		A.45
GPS1BHAN	101246	C.3	IPB1-N422B	132215	F.69	MACN202AR	103558	A.48	MC2C310AR		A.45
GPS1BHAP	101247	C.3	IPB1-R411B	132203	F.69	MACN202AT	100998	A.48	MC2C310AT		A.45
GPS1BHAR	101248	C.3	IPSF1	223000	F.70	MACN211AR	103557	A.48	MC2C400AT		A.47
GPS1BSAA	101211	C.3	IR	201944	G.27	MACN211AT	100999	A.48	MC2C800AT		A.47
GPS1BSAB	101212	C.3	IUGA-B211	130060	G.25	MACN413AR	103561	A.48	MC2I301ATD	100538	A.46
GPS1BSAC	101213	C.3	IUGA-B211 S	209140	G.25	MACN413AT	100995	A.48	MC2I310ATD	100559	A.46
GPS1BSAD	101214	C.3	IUGA-B411	130082	G.25	MACN422AR	103560	A.48	MC2K301ATD	103591	A.46
GPS1BSAE	101215	C.3	IUGE-B411	130094	G.25	MACN422AT	100996	A.48	MC2K310ATD	103590	A.46
GPS1BSAF	101216	C.3	IUGH-B411	130088	G.25	MACN431AR	103559	A.48	MCRA004AF		B.9
GPS1BSAG	101217	C.3	IUGI-B411	130090	G.25	MACN431AT	100997	A.48	MCRA004AI		B.9
GPS1BSAH	101218	C.3	IUGL-B411	130096	G.25	MAGL110AT	100608	A.51	MCRA004AR		B.9
GPS1BSAJ	101219	C.3	IUGM-B311	130104	G.25	MARL101AF	100516	B.11	MCRA004AT		B.9
GPS1BSAK	101220	C.3	IUGP-B311	130100	G.25	MARL101AFS	100522	B.11	MCRA013AF		B.9
GPS1BSAL	101221	C.3	IUGQ-B311	130102	G.25	MARL101AI	100518	B.11	MCRA013AI		B.9
GPS1BSAM	101222	C.3	IUGR-B411	130086	G.25	MARL101AIS	100524	B.11	MCRA013AR		B.9
GPS1BSAN	101223	C.3	IUGT-B311	130098	G.25	MARL101AR	103557	B.11	MCRA013AT		B.9
GPS1BSAP	101224	C.3	IUGU-B211 S	130057	G.25	MARL101ARS	103298	B.11	MCRA022AF		B.9
GPS1BSAR	101225	C.3	IUGU-B411	130084	G.25	MARL101AT	100514	B.11	MCRA022AI		B.9
GPS1MHAA	101280	C.7	IZMA-B311	130144	G.26	MARL101ATS	100520	B.11	MCRA022AR		B.9
GPS1MHAB	101281	C.7	IZMR-B311	130146	G.26	MARL110AF	100515	B.11	MCRA022AT		B.9
GPS1MHAC	101282	C.7	IZMS-B311	130145	G.26	MARL110AFS	100521	B.11	MCRA031AF		B.9
GPS1MHAD	101283	C.7				MARL110AI	100517	B.11	MCRA031AI		B.9
GPS1MHA	101284	C.7	KB5E		A.64	MARL110AIS	100523	B.11	MCRA031AR		B.9
GPS1MHAF	101285	C.7	KB6E		A.64	MARL110AR	103556	B.11	MCRA031AT		B.9
GPS1MHAG	101286	C.7	KB7E		A.64	MARL110ARS	103299	B.11	MCRA040AF		B.9
GPS1MHAH	101287	C.7	KM5E		A.64	MARL110AT	100513	B.11	MCRA040AI		B.9
GPS1MHAJ	101288	C.7	KM6E		A.64	MARL110ATS	100519	B.11	MCRA040AR		B.9
GPS1MHAK	101289	C.7	KM7E		A.64	MARN202AR	103351	B.10	MCRA040AT		B.9
GPS1MHAL	101290	C.7	KRC24	104760	A.65	MARN202AT	100992	B.10	MCRC022AF		B.9
GPS1MHAM	101291	C.7	KRC380/415	104762	A.65	MARN211AR	103350	B.10	MCRC022AI		B.9
GPS1MHAN	101292	C.7	KRC48/260	104761	A.65	MARN211AT	100993	B.10	MCRC022AR		B.9
GPS1MHAP	101293	C.7	KVB10E	104597	A.67	MARN220AR	103349	B.10	MCRC022AT		B.9
GPS1MHAR	101294	C.7	KVB10I	104692	A.66	MARN220AT	100994	B.10	MCRC031AF		B.9
GPS1MSAA	101257	C.7	KVB12E	104587	A.67	MARN404AR	103300	B.10	MCRC031AI		B.9
GPS1MSAB	101258	C.7	KVB12I	104693	A.66	MARN404AT	100987	B.10	MCRC031AR		B.9
GPS1MSAC	101259	C.7	KVB75E	104694	A.67	MARN413AR	103355	B.10	MCRC031AT		B.9
GPS1MSAD	101260	C.7	KVB75I	104690	A.66	MARN413AT	100988	B.10	MCRC040AF		B.9
GPS1MSAE	101261	C.7	KVB95E	104695	A.67	MARN422AR	103354	B.10	MCRC040AI		B.9
GPS1MSAF	101262	C.7	KVB95I	104691	A.66	MARN422AT	100989	B.10	MCRC040AR		B.9
GPS1MSAG	101263	C.7	KVP08E	116212	A.67	MARN431AR	103353	B.10	MCRC040AT		B.9
GPS1MSAH	101264	C.7	KVP10E	133380	A.67	MARN431AT	100990	B.10	MCRI022ATD	100532	B.9
GPS1MSAJ	101265	C.7	KVP10G	104771	A.66	MARN440AR	103352	B.10	MCRI031ATD	100531	B.9
GPS1MSAK	101266	C.7	KVP10I	133371	A.66	MARN440AT	100991	B.10	MCRI040ATD	100530	B.9
GPS1MSAL	101267	C.7	KVP10U	133374	A.66	MATV10AR	103563	A.69	MCRC022ATD	100535	B.9
GPS1MSAM	101268	C.7	KVP12E	116235	A.67	MATV10AT	101022	A.69	MCRC031ATD	100534	B.9
GPS1MSAN	101269	C.7	KVP12G	104767	A.66	MBOA		B.9	MCRC040ATD	100533	B.9
GPS1MSAP	101270	C.7	KVP12I	113633	A.66	MBOC		B.9	MG0004PATD	209780	A.51

By catalogue number

Intro

B

B

C

D

E

F

G

H

I

J/X



Cat. no	Ref. no.	Page	Cat. no	Ref. no.	Page	Cat. no	Ref. no.	Page	Cat. no	Ref. no.	Page
MG0004QAT0	137566	A.51	OPCM8TCP	404824	H.39	P9ARDLS	187300	F.29	P9801FN	187012	F.20
MG0004RAT0	137567	A.51	OPCPDP	404848	H.39	P9ARDLS001	187315	F.29	P9801VN	187001	F.20
MG0006PAT0	209781	A.51	OPCPRT	404825	H.39	P9ARDLS002	187316	F.29	P9801VR	187003	F.20
MG0006QAT0	116074	A.51	OPCPRES	404852	H.40	P9ARDLS006	187305	F.29	P9802VN	187008	F.20
MG0006RAT0	116402	A.51	OPCRLY	404849	H.40	P9ARDLS017	187309	F.29	P9810BN	187018	F.23
MMHO	100547	B.12	OPCRMKNC	404850	H.39	P9ARDLS018	187310	F.29	P9810FH	187015	F.20
MPOAAE1	100544	B.12	OPCSAFE	404815	H.40	P9ARDLS026	187311	F.29	P9810FN	187013	F.20
MPOAAE2	100545	B.12	OPCSTERM	404822	H.41	P9ARDLS027	187312	F.29	P9810VA	187004	F.20
MPOCAE3	100546	B.12	OPCUSB	404861	H.41	P9ARDLS028	187302	F.29	P9810VN	187002	F.20
MPODAE4	100536	B.12	OPCUSB6X	404860	H.41	P9ARDLS029	187301	F.29	P9811VN	187000	F.20
MREBC10AC2	100541	B.12	P...			P9ARDLS030	187318	F.29	P9820VN	187009	F.20
MREBC20AC2	100542	B.12	P9ACA6	188804	F.20	P9ARDLS031	187313	F.29	P9DPLS4700	154700	F.9
MSK-B250/220-1,5	209997	A.154	P9ACAFV	187847	F.30	P9ARDLS032	187314	F.29	P9DPLS4701	154701	F.9
MT03A	101000	A.69	P9ACDPP	187843	F.30	P9ARDLS201	187319	F.29	P9DPLS4720	154720	F.9
MT03B	101001	A.69	P9ACFS3	187841	F.30	P9ARDLS202	187320	F.29	P9DPLS4721	154721	F.9
MT03C	101002	A.69	P9ACFS5	187842	F.30	P9ARDPL	187350	F.29	P9DPLNRG00	186880	F.10
MT03D	101003	A.69	P9ACFSM	187846	F.20	P9ARDPL001	187365	F.29	P9DPLNRG01	186890	F.10
MT03E	101004	A.69	P9ACPBS	188015	F.32	P9ARDPL002	187366	F.29	P9DPLNRS00	186882	F.10
MT03F	101005	A.69	P9ACPBS039	188030	F.32	P9ARDPL006	187355	F.29	P9DPLNRS01	186892	F.10
MT03G	101006	A.69	P9ACPBS201	188201	F.32	P9ARDPL017	187359	F.29	P9DPLVRG00	186881	F.10
MT03H	101007	A.69	P9ACPBS202	188202	F.32	P9ARDPL018	187360	F.29	P9DPLVRG01	186891	F.10
MT03I	101008	A.69	P9ACPBS203	188203	F.32	P9ARDPL026	187361	F.29	P9DPLVRS00	186883	F.10
MT03J	101009	A.69	P9ACPBS204	188204	F.32	P9ARDPL027	187362	F.29	P9DPLVRS01	186893	F.10
MT03K	101010	A.69	P9ACPBS205	188205	F.32	P9ARDPL028	187352	F.29	P9EPA01Y02	189010	F.25
MT03L	101011	A.69	P9ACPBS206	188206	F.32	P9ARDPL029	187351	F.29	P9EPA01Y03	189011	F.25
MT03M	101012	A.69	P9ACPBS207	188207	F.32	P9ARDPL030	187368	F.29	P9EPA02Y01	189016	F.25
MT03N	101013	A.69	P9ACPBS208	188208	F.32	P9ARDPL031	187363	F.29	P9EPA03Y01	189018	F.25
MT03P	101014	A.69	P9ACPBS215	188215	F.32	P9ARDPL032	187364	F.29	P9EPA03Y05	189022	F.25
MT03R	101015	A.69	P9ACPBS222	188222	F.32	P9ARDPL201	187369	F.29	P9EPAG1Y01W	189008	F.25
MT03RA	103540	A.69	P9ACPBS224	188224	F.32	P9ARDPL202	187370	F.29	P9EPAG1Y06N	189009	F.25
MT03RB	103541	A.69	P9ACPBS231	188231	F.32	P9ARHPR	187491	F.30	P9EPAG1Y0N	189007	F.25
MT03RC	103542	A.69	P9ACPBS232	188232	F.32	P9ARPB	188002	F.32	P9EPC01X00	215432	F.25
MT03RD	103543	A.69	P9ACPBS233	188233	F.32	P9ARPTM	188019	F.32	P9EPC01X01	215433	F.25
MT03RE	103544	A.69	P9ACPBS234	188234	F.32	P9ARPWM	188028	F.32	P9EPE01	189001	F.24
MT03RF	103545	A.69	P9ACPBS239	188239	F.32	P9ARRE4	187492	F.30	P9EPE02	189002	F.24
MT03RG	103546	A.69	P9ACPBS243	188243	F.32	P9ARSCMB	188044	F.19	P9EPE03	189003	F.24
MT03RH	103547	A.69	P9ACPBS258	188258	F.32	P9ARSCMN	188043	F.19	P9EPE04	189004	F.24
MT03RI	103548	A.69	P9ACPIU	P9ACPIU	F.32	P9ARSGMB	187496	F.19	P9EPE06	189005	F.24
MT03RJ	103549	A.69	P9ACPTS	188018	F.32	P9ARSGMN	187495	F.19	P9EPEG1	189000	F.24
MT03RK	103550	A.69	P9ACPRS	188017	F.32	P9ARSN1	188805	F.30	P9EPEG2	189006	F.24
MT03RL	103551	A.69	P9ACRCL	187840	F.30	P9ARTAPN	116099	F.32	P9EPEM	189200	F.24
MT03RM	103552	A.69	P9ACVLR	187844	F.30	P9ARTAPN028	118846	F.32	P9EPL02X01	189136	F.26
MT03RN	103553	A.69	P9ACWAF	187845	F.30	P9ARTAPN039	116140	F.32	P9EPL02X02	189137	F.26
MT03RP	103554	A.69	P9ADCST	187796	F.10	P9ARTAPN040	116991	F.32	P9EPL03X01	189138	F.26
MVBOR	100543	B.12	P9AELN	189030	F.24	P9ARTAPN042	116141	F.32	P9EPL03X02	189139	F.26
MVB0T	101021	A.69	P9AELN006	189041	F.24	P9ARTAPN201	116143	F.32	P9EPL03X03	189140	F.26
MVEOR	103562	A.69	P9AELN028	189042	F.24	P9ARTAPN202	116144	F.32	P9EPL04X01	189141	F.26
MVEOT	101020	A.69	P9AELN029	189043	F.24	P9ARTAPN206	116145	F.32	P9MCB	184696	F.17
MVPOC	100600	A.50	P9AELN035	189044	F.24	P9ARTAPN212	116147	F.32	P9MCC	184697	F.17
N...			P9AELN038	189045	F.24	P9ARTAPN213	1161	F.32	P9MCD	184695	F.17
N211B	116113	F.69	P9AELN039	189046	F.24	P9ARTAPN291	116150	F.32	P9MEM53111	153111	F.8
N222B	116664	F.69	P9AELN042	189047	F.24	P9ARTBM	188001	F.31	P9MER3RN	184070	F.11
N411B	116663	F.69	P9AELN201	189032	F.24	P9ARTBS	188000	F.31	P9MER4RN	184071	F.11
N422B	116665	F.69	P9AELN202	189031	F.24	P9ARTTM	188019	F.31	P9METS3121	153121	F.8
NEMA1ACA2	404831	H.39	P9AELN203	189038	F.24	P9ARTTS	188012	F.31	P9MLD53610	153610	F.9
NEMA1ACA3	404832	H.39	P9AELN204	189037	F.24	P9ARTWM	188008	F.31	P9MLD53611	153611	F.9
NEMA1ACB3	404833	H.39	P9AELN205	189035	F.24	P9ARTWS	188005	F.31	P9MLD53620	153623	F.9
NEMA1ACB4	404834	H.39	P9AELN206	189036	F.24	P9ASBGB 006	187552	F.28	P9MLD53621	153621	F.9
NEMA1ACC3	404835	H.39	P9AELN214	189033	F.24	P9ASBGB 028	187551	F.28	P9MMB2A	184712	F.19
NEMA1ACC4	404836	H.39	P9AELN215	189034	F.24	P9ASBGB 202	189859	F.28	P9MMB2B	184713	F.19
NEMA1ACLP1	404798	H.26	P9AELN222	189152	F.24	P9ASBGL 037	187543	F.28	P9MMB2F	184710	F.19
NEMA1ACLP2	404799	H.26	P9AELN224	189154	F.24	P9ASBGN 006	187517	F.28	P9MMB2T	184711	F.19
NEMA1ACLP3	404800	H.26	P9AEMT	189029	F.24	P9ASBGN 028	187511	F.28	P9MMB4F	184740	F.19
NEMA1ACLP4	404801	H.26	P9ARAM32	188801	F.32	P9ASBGN 029	187550	F.28	P9MMB4T	184741	F.19
NEMA1ACLP5	404802	H.26	P9ARBBG 006	187152	F.28	P9ASBGN 030	187545	F.28	P9MMN2A	184702	F.19
NLTSBT	222284	F.65	P9ARBBG 028	187151	F.28	P9ASBGN 202	187548	F.28	P9MMN2B	184703	F.19
NLTSET	222285	F.65	P9ARBBG 202	188909	F.28	P9ASBGR 029	187510	F.28	P9MMN2F	184700	F.19
NLT73BD	222278	F.65	P9ARBG 037	187143	F.28	P9ASBGR 201	187547	F.28	P9MMN2T	184701	F.19
NLT75AJ	222287	F.65	P9ARBBG 006	187117	F.28	P9ASBGV 006	187518	F.28	P9MMN4F	184720	F.19
NLT75AN	222288	F.65	P9ARBBG 017	187125	F.28	P9ASBGV 028	187512	F.28	P9MMN4T	184721	F.19
NLT75BD	222286	F.65	P9ARBBG 018	187127	F.28	P9ASBGV 030	187546	F.28	P9MPL53502	153502	F.9
NLT77AJ	222280	F.65	P9ARBBG 028	187111	F.28	P9ASBGV 202	187549	F.28	P9MPL53511	153511	F.9
NLT77AN	222281	F.65	P9ARBBG 029	187150	F.28	P9ASBSB 006	187652	F.28	P9MPL53513	153513	F.9
NLT77BD	222279	F.65	P9ARBBG 030	187145	F.28	P9ASBSB 028	187651	F.28	P9MPL53514	153514	F.9
NLT90BT	222307	F.65	P9ARBBG 202	187148	F.28	P9ASBSB 202	189928	F.28	P9MPL53515	153515	F.9
NLT9TC	222282	F.65	P9ARBBG 029	187110	F.28	P9ASBSL 037	187643	F.28	P9MPN53006	153006	F.8
NMETV	124908	G.2	P9ARBBG 036	187144	F.28	P9ASBSN 006	187617	F.28	P9MPN53007	153007	F.8
NMETV t AU	124911	G.2	P9ARBBG 201	187147	F.28	P9ASBSN 028	187611	F.28	P9MPN53061	153061	F.8
NMIVV	124929	G.2	P9ARBBG 006	187118	F.28	P9ASBSN 029	187650	F.28	P9MPS21G	184690	F.17
NMMFV	124930	G.2	P9ARBBG 028	187112	F.28	P9ASBSN 030	187645	F.28	P9MPS22G	184691	F.17
NMRDV 2-6	124915	G.2	P9ARBBG 030	187146	F.28	P9ASBSN 202	187648	F.28	P9MPS23G	184692	F.17
NMRDV 2-60	124916	G.2	P9ARBBG 202	187149	F.28	P9ASBSR 029	187610	F.28	P9MPS34G	184693	F.17
NMRDV 2-600	124917	G.2	P9ARBSB 006	187252	F.28	P9ASBSR 201	187647	F.28	P9MPS35G	184694	F.17
NMTVC 2	124901	G.2	P9ARBSB 028	187251	F.28	P9ASBSV 006	187618	F.28	P9MRG	184771	F.18
O...			P9ARBSB 202	188978	F.28	P9ASBSV 028	187612	F.28	P9MSC53435	153435	F.8
OPC24VPS	404815	H.40	P9ARBSN 006	187217	F.28	P9ASBSV 030	187646	F.28	P9MSC53497	153497	F.8
OPC4XPED	404845	H.41	P9ARBSN 028	187211	F.28	P9ASBSV 202	187649	F.28	P9MSM53293	153293	F.8
OPCAIO	404816	H.57	P9ARBSN 029	187250	F.28	P9ASEBG	187795	F.30	P9MSM53391	153391	F.8
OPCBAC	404817	H.56	P9ARBSN 030	187245	F.28	P9ASHAC	187794	F.30	P9MWR	184770	F.18
OPCCOVER4142	404846	H.41	P9ARBSN 202	187248	F.28	P9ASHP3	187792	F.30	P9MZ	184772	F.18
OPCCOVERS1	404847	H.41	P9ARBSR 029	187210	F.28	P9ASHP5	187793	F.30	P9PDHF	187056	F.20
OPCDEV	404818	H.39	P9ARBSR 201	187247	F.28	P9ASTBS	188010	F.31	P9PDMVD	187040	F.21
OPCEIP	404820	H.39	P9ARBSV 006	187218	F.28	P9ASTTS	188014	F.31	P9PDMVJ	187041	F.21
OPCENC	404819	H.40	P9ARBSV 028	187212	F.28	P9ASTWS	188011	F.31	P9PDNB0	187070	F.23
OPCGPIO	404821	H.40	P9ARBSV 030	187246	F.28	P9801BN	187017	F.23	P9PDNF0	187055	F.21
OPCLON	404823	H.56	P9ARBSV 202	187249	F.28	P9801FH					

Cat. no	Ref. no.	Page	Cat. no	Ref. no.	Page	Cat. no	Ref. no.	Page	Cat. no	Ref. no.	Page
P9PDTV0	187027	F.21	P9XSMDSN	185150	F.12	PRC4M40DCGL	221853	B.3	QT10210N21MS	169091	I.8
P9PRDVN	187022	F.21	P9XSMION	185120	F.12	PRC4M40DCJL	221854	B.3	QT10210U21MS	169085	I.9
P9PREVJ	187025	F.21	P9XSMUON	185190	F.12	PRCG-ES15/ZN	220912	B.3	QT10310N21MS	169092	I.8
P9PREVL	187026	F.21	P9XSMXON	185330	F.12	PRCG-ES15/3N	221442	B.3	QT10310U21MS	169086	I.9
P9PRLVJ	187021	F.21	P9XSMZON	185200	F.12	PRCG-ES15/4N	221934	B.3	QT10390N21MS	169093	I.8
P9PRNVJ	187023	F.21	P9XSMZ1N	185240	F.12	PRCG1052	220914	B.3	QT10390U21MS	169087	I.9
P9PRNVN	187024	F.21	P9XSMZ3N	185320	F.12	PRCG11	220648	B.4	QT10460N21MS	169094	I.8
P9PRTVN	187028	F.21	P9XSMZ5N	185280	F.12	PRCG8	220217	B.4	QT10460U21MS	169088	I.9
P9SBD	186773	F.18	P9XSVDON	185370	F.13	PRCGZT80	221918	B.5	QT10580N21MS	169095	I.8
P9SBM	186774	F.18	P9XSVDSN	185373	F.13	PRCM21N	222101	B.6	QT10580U21MS	169089	I.8
P9SCD	186695	F.17	P9XSVXON	185392	F.13	PRCM21P	222100	B.6	QT10650N21MS	169096	I.8
P9SEC4RA95	186073	F.11	P9XSVZON	185379	F.13	PRCM31G	222104	B.6	QT10820U21MS	169090	I.8
P9SEM3RL	186551	F.16	P9XSVZ3N	185391	F.13	PRCM31R	222102	B.6	QT10950N21MS	169097	I.8
P9SEM3RN	186031	F.11	P9XZ	185772	F.18	PRCM32G	222105	B.6	QT11100N21MS	169098	I.8
P9SER4RA	186072	F.11	PBF23E8DA	107152	A.13	PRCM32R	222103	B.6	QT11400N21MS	169099	I.8
P9SET4R	186061	F.11	PBF23ECDA	107153	A.13	PRCM33G	222106	B.6	QT2008U21MS	169100	I.9
P9SET4RL1	186561	F.16	PCP12G	241749	A.66	PRCM33R	222109	B.6	QT20017U21MS	169101	I.9
P9SSCDOA95	186400	F.14	PRC1S13BDL	222004	B.5	PRCM41G	222107	B.6	QT20031U21MS	169102	I.9
P9SSCDSA95	186409	F.14	PRC1S13BNL	222013	B.5	PRCM41R	222110	B.6	QT20044U21MS	169103	I.9
P9SSCIC95	186410	F.14	PRC1S13CBL	222007	B.5	PRCM42G	222124	B.6	QT20058U21MS	169104	I.9
P9SSCZOT95	186439	F.14	PRC1S13CDL	222008	B.5	PRCM42R	222111	B.6	QT20072U21MS	169105	I.9
P9SSCZ3C95	186467	F.15	PRC1T10ADL	221883	B.5	PRCM43G	222125	B.6	QT20085U21MS	169106	I.9
P9SSCZ5A95	186461	F.15	PRC1T10AJL	221884	B.5	PRCM43R	222112	B.6	QT20105U21MS	169107	I.9
P9SSMD0N	186110	F.12	PRC1T10ANL	221885	B.5	PRCM51	222113	B.6	QT20145U21MS	169108	I.9
P9SSMD5N	186140	F.12	PRC1T10CBL	221875	B.5	PRCM52	222114	B.6	QT20170U21MS	169109	I.9
P9SSME0N	186170	F.12	PRC1T10CDL	221876	B.5	PRCM53	222115	B.6	QT20210U21MS	169110	I.9
P9SSME1N	186210	F.12	PRC1T10CJL	221877	B.5	PRCM71	222121	B.6	QT20310U21MS	169111	I.9
P9SSMION	186120	F.12	PRC1T20ADL	221868	B.5	PRCM73	222122	B.6	QT20390U21MS	169112	I.9
P9SSMISN	186150	F.12	PRC1T20AJL	221869	B.5	PRCM91G	222126	B.6	QT20460U21MS	169113	I.9
P9SSMUON	186190	F.12	PRC1T20ANL	221870	B.5	PRCM91R	222116	B.6	QT20580U21MS	169114	I.9
P9SSMU1N	186230	F.12	PRC1T20CBL	221860	B.5	PRCM93G	222120	B.6	QT20820U21MS	169115	I.9
P9SSMXON	186330	F.12	PRC1T20CDL	221861	B.5	PRCMS16	221920	B.5	QT3008N21MS	169119	I.8
P9SSMZON	186200	F.12	PRC1T20CJL	221862	B.5	PRCMS35	220915	B.3	QT30017N21MS	169120	I.8
P9SSMZ1N	186240	F.12	PRC2P20ABL	220019	B.4	PRCP211	220218	B.4	QT30031N21MS	169121	I.8
P9SSMZ3N	186320	F.12	PRC2P20ADL	220020	B.4	PRCR159	220219	B.4	QT30044N21MS	169122	I.8
P9SSMZ5N	186280	F.12	PRC2P20AGL	220021	B.4	PRCT1AD	221896	B.5	QT30058N21MS	169123	I.8
P9SZ	186772	F.18	PRC2P20AJL	220024	B.4	PRCT1AJ	221897	B.5	QT30072N21MS	169124	I.8
P9XaVION	185371	F.13	PRC2P20ANL	220026	B.4	PRCT1AN	221898	B.5	QT30085N21MS	169125	I.8
P9XBD	185773	F.18	PRC2P20CBL	220022	B.4	PRCT1CB	221890	B.5	QT30105N21MS	169126	I.8
P9XBM	185774	F.18	PRC2P20CDL	220023	B.4	PRCT1CD	221891	B.5	QT30145N21MS	169127	I.8
P9XCD	185695	F.17	PRC2P20CGL	220025	B.4	PRCT1CJ	221892	B.5	QT30170N21MS	169128	I.8
P9XEC4RA95N	185079	F.11	PRC2P20CJL	220027	B.4	PRCT2AD	221913	B.5	QT30210N21MS	169129	I.8
P9XEC50777	150777	F.8	PRC2P20DCBL	220041	B.4	PRCT2AJ	221914	B.5	QT30310N21MS	169130	I.8
P9XEM52111	152111	F.8	PRC2P20DCDL	220042	B.4	PRCT2AN	221915	B.5	QT30390N21MS	169131	I.8
P9XER3RN	185070	F.11	PRC2P20DCGL	220043	B.4	PRCT2CB	221905	B.5	QT30460N21MS	169132	I.8
P9XER4RAN	185077	F.11	PRC2P20DCJL	220044	B.4	PRCT2CD	221906	B.5	QT30580N21MS	169133	I.8
P9XER4RAW	185078	F.11	PRC3P30ABL	220310	B.4	PRCT2CJ	221907	B.5	QT30650N21MS	169134	I.8
P9XER4RN	185071	F.11	PRC3P30ADL	220311	B.4	PRCTR	221921	B.5	QT30950N21MS	169135	I.8
P9XER50775	150775	F.8	PRC3P30AGL	220312	B.4	PRCTR1	220916	B.3	QT31100N21MS	169136	I.8
P9XERW50776	150776	F.8	PRC3P30AJL	220315	B.4	PRCZ11	220647	G.3	QT31400N21MS	169137	I.8
P9XET4RL2	185571	F.16	PRC3P30ANL	220317	B.4	PRCZ8	220216	B.4	R...		
P9XET52121	152121	F.8	PRC3P30CBL	220313	B.4	PTP04	113850	A.58	RCF-1 AJ	124433	G.4
P9XLD52610	152610	F.9	PRC3P30CDL	220314	B.4	PTP08	113852	A.58	RCF-1 AU	124435	G.4
P9XLD52611	152611	F.9	PRC3P30CGL	220316	B.4	PTP10	113853	A.58	RCF-1 EN	124434	G.4
P9XLD52620	152620	F.9	PRC3P30CJL	220318	B.4	PTP45	113851	A.58	RCRT 6 - 60AJ	123623	G.3
P9XLD52621	152621	F.9	PRC3P30DCBL	220335	B.4	PTPCK11	103749	A.65	RCRT 6 - 60AN	123624	G.3
P9XMB2A	185712	F.19	PRC3P30DCDL	220336	B.4	PTPCK75	103747	A.65	RDF1-50AU	123985	G.5
P9XMB2B	185713	F.19	PRC3P30DCGL	220337	B.4	PTPCK95	103748	A.65	RDHA 1-1,2AEU	123965	G.3
P9XMB2F	185710	F.19	PRC3P30DCJL	220338	B.4	PVP10G	241748	A.66	RDHA 1-10AEN	123964	G.3
P9XMB2T	185711	F.19	PRC4M20ABL	220710	B.3	PVP85G	241747	A.66	RDHT 1-1,2AEN	123744	G.3
P9XMB4F	185740	F.19	PRC4M20ADL	220711	B.3	Q...			RDHT 1-10AEN	123754	G.3
P9XMB4T	185741	F.19	PRC4M20AGL	220712	B.3	QA02P008S	120881	I.3	RDIT2-02VEN	124354	G.4
P9XMN2F	185700	F.19	PRC4M20AJL	220715	B.3	QA02P017S	120882	I.3	RDIT2-5AEN	124754	G.4
P9XMN2T	185701	F.19	PRC4M20ANL	220717	B.3	QA02P022S	120883	I.3	RDIT2-400VEN	124184	G.4
P9XMN4F	185720	F.19	PRC4M20CBL	220713	B.3	QA02P031S	120884	I.3	RE1D	101866	A.75
P9XMN4T	185721	F.19	PRC4M20CDL	220714	B.3	QA02P044S	120885	I.3	RE1H	101867	A.75
P9XPL52502	152502	F.9	PRC4M20CGL	220716	B.3	QA02P058S	120886	I.3	RE1K	101868	A.75
P9XPL52511	152511	F.9	PRC4M20CJL	220718	B.3	QA12P008S	120892	I.3	RE1M	101869	A.75
P9XPL52513	152513	F.9	PRC4M20DCBL	220754	B.3	QA12P017S	120893	I.3	RE1S	101870	A.75
P9XPL52514	152514	F.9	PRC4M20DCDL	220755	B.3	QA12P022S	120894	I.3	RE1W	101871	A.75
P9XPL52515	152515	F.9	PRC4M20DCGL	220756	B.3	QA12P031S	120895	I.3	RE1XP	247302	A.75
P9XPN52002	152002	F.8	PRC4M20DCJL	220757	B.3	QA12P044S	120896	I.3	RE2H	101872	A.75
P9XPN52007	152007	F.8	PRC4M30ABL	221051	B.3	QA12P058S	120897	I.3	RE2M	101873	A.75
P9XPN52061	152061	F.8	PRC4M30ADL	221052	B.3	QA22P008S	120898	I.3	RE2XP	247303	A.75
P9XRG	185771	F.18	PRC4M30AGL	221053	B.3	QA22P017S	120899	I.3	RE3E	101874	A.75
P9XSC52434	152434	F.8	PRC4M30AJL	221056	B.3	QA22P022S	120900	I.3	RETC	247795	A.75
P9XSC52435	152435	F.8	PRC4M30ANL	221058	B.3	QA22P031S	120901	I.3	RL4RA004R	B.15	
P9XSC52496	152496	F.8	PRC4M30CBL	221054	B.3	QA22P044S	120902	I.3	RL4RA004T	B.15	
P9XSC52497	152497	F.8	PRC4M30CDL	221055	B.3	QA22P058S	120903	I.3	RL4RA022G	B.15	
P9XSCDOA95	185400	F.14	PRC4M30CGL	221057	B.3	QA32P008S	120904	I.3	RL4RA022R	B.15	
P9XSCDOE95	185401	F.14	PRC4M30CJL	221059	B.3	QA32P017S	120905	I.3	RL4RA022T	B.15	
P9XSCDOK95	185402	F.14	PRC4M30DCBL	221074	B.3	QA32P022S	120906	I.3	RL4RA031R	B.15	
P9XSCDSA95	185409	F.14	PRC4M30DCDL	221075	B.3	QA32P031S	120907	I.3	RL4RA031T	B.15	
P9XSCIC95	185410	F.14	PRC4M30DCGL	221076	B.3	QA32P044S	120908	I.3	RL4RA040R	B.15	
P9XSCUOT95	185432	F.14	PRC4M30DCJL	221077	B.3	QA32P058S	120909	I.3	RL4RA040T	B.15	
P9XSCZO95	185433	F.14	PRC4M40ABL	221809	B.3	QAOPTDIN	120910	I.3	RL4RD004R	B.15	
P9XSCZOC95	185434	F.14	PRC4M40ADL	221810	B.3	QT10008U21MS	169075	I.8	RL4RD004T	B.15	
P9XSCZOE95	185435	F.14	PRC4M40AJL	221811	B.3	QT10017U21MS	169076	I.8	RL4RD022G	B.15	
P9XSCZOT95	185439	F.14	PRC4M40ANL	221814	B.3	QT10031U21MS	169077	I.8	RL4RD022R	B.15	
P9XSCZ3C95	185467	F.15	PRC4M40ANL	221816	B.3	QT10044U21MS	169078	I.8	RL4RD022T	B.15	
P9XSCZ5A95	185461	F.15	PRC4M40CBL	221812	B.3	QT10058U21MS	169079	I.8	RL4RD031R	B.15	
P9XSCZ5C95	185462	F.15	PRC4M40CDL	221813	B.3	QT10072U21MS	169080	I.8	RL4RD031T	B.15	
P9XSCZ5H95	185463	F.15	PRC4M40CGL	221815	B.3	QT10085U21MS	169081	I.8	RL4RD040R	B.15	
P9XSM52293	152293	F.8	PRC4M40CJL	221817	B.3	QT10105U21MS	169082	I.8	RL4RD040T	B.15	
P9XSM52391	152321	F.8	PRC4M40DCBL	221851	B.3	QT10145U21MS	169083	I.8	RMACLP1	404806	H.26
P9XSMDO0N	185110	F.12	PRC4M40DCDL	221852	B.3	QT10170U21MS	169084	I.8	RMKYPDAC	404797	H.39

By catalogue number

Intro

B

B

C

D

Cat. no	Ref. no.	Page	Cat. no	Ref. no.	Page	Cat. no	Ref. no.	Page	Cat. no	Ref. no.	Page
RMKYPDACLP1	404797	H.26	RT1RU	114101	A.71	RTXRRU	113666	A.14	U200AMP	167437	H.9
RMLF		B.16	RT1RV	114102	A.71	RTXS	113855	A.14	U200AN101	167446	H.9
RMM 2 EN	124104	G.5	RT1RW	114103	A.71	RTXSL	113856	A.14	U200AN102	167447	H.9
RPDF2-50AU	124025	G.5	RT1S	113712	A.71	S...			U200AN103	167448	H.9
RS01NAJ	124373	G.4	RT1T	113713	A.71	SBELA	101017	A.57	U200APB	167433	H.9
RS01NEN	212759	G.4	RT1U	113714	A.71	SFAL1	120024	C.33	U200ARS232	167436	H.9
RSF1-50ANU	124051	G.5	RT1V	113715	A.71	SFAK01	120026	C.33	U200ARS485	167435	H.9
RSSF1-50AU	124622	G.5	RT1W	113716	A.71	SFAK10	120025	C.33	U200AW05	167441	H.9
RSS13/64TA10	211742	A.154	RT22D	113650	A.71	SFAL11D	120022	C.33	U200AW10	167442	H.9
RSS13/64TA100	211744	A.154	RT22E	113651	A.71	SFAL11N	120020	C.33	U200AW20	167443	H.9
RSS13/64TA120	243281	A.154	RT22G	113652	A.71	SFAL11S	120027	C.33	U200AW30	167444	H.9
RSS13/64TA1200	213034	A.154	RT22H	113653	A.71	SFAL20D	120023	C.33	U200AW50	167445	H.9
RSS13/64TA15	211737	A.154	RT22J	113654	A.71	SFAL20N	120021	C.33	U200F3100A	167476	H.14
RSS13/64TA18	211727	A.154	RT22L	113655	A.71	SFALPEN	264826	C.33	U200F3150A	167477	H.14
RSS13/64TA180	211744	A.154	RT22M	113656	A.71	SFB0AJ	120030	C.33	U200F3180A	167478	H.14
RSS13/64TA220	212702	A.154	RT22RD	114124	A.71	SFB0AN	120031	C.33	U200F34048SMA	167474	H.14
RSS13/64TA27	244192	A.154	RT22RE	114141	A.71	SFB0AU	120032	C.33	U200F370A	167475	H.14
RSS13/64TA270	214399	A.154	RT22RG	114126	A.71	SFB0RJ	120034	C.33	U200F611TA1	167453	H.14
RSS13/64TA300	211714	A.154	RT22RH	114127	A.71	SFB0RJM	107256	C.33	U200F627TA2	167454	H.14
RSS13/64TA33	211728	A.154	RT22RJ	114128	A.71	SFBORN	120035	C.33	U200F709TA1	167456	H.14
RSS13/64TA330	211745	A.154	RT22RL	114143	A.71	SFBORNNM	120114	C.33	U200F719TA2	167457	H.14
RSS13/64TA39	211730	A.154	RT22RM	114130	A.71	SFBORU	120036	C.33	U200F739TA3	167458	H.14
RSS13/64TA390	211746	A.154	RT2A	113717	A.71	SFBORUM	120115	C.33	U200F905TA1	167459	H.14
RSS13/64TA47	211731	A.154	RT2B	113718	A.71	SFE04	120042	C.34	U200F910TA2	167460	H.14
RSS13/64TA470	244191	A.154	RT2C	113719	A.71	SFE04K1	216604	C.34	U200F928TA3	167461	H.14
RSS13/64TA5,6	211735	A.154	RT2D	113720	A.71	SFE05	120043	C.34	U201N00K4FS	167400	H.9
RSS13/64TA6,8	214869	A.154	RT2E	113721	A.71	SFE0K2	120047	C.34	U201N00K4SS	167411	H.9
RSS13/64TA680	214580	A.154	RT2G	113722	A.71	SFK0A	120001	C.32	U201N00K7FS	167401	H.9
RSS13/64TA8,2	204177	A.154	RT2H	113723	A.71	SFK0B	120002	C.32	U201N00K7SS	167412	H.9
RSS13/64TA82	204177	A.154	RT2J	113724	A.71	SFK0C	120003	C.32	U201N01K5FS	167402	H.9
RSS13/64TA820	214400	A.154	RT2L	113725	A.71	SFK0D	120004	C.32	U201N01K5SS	167413	H.9
RSS20/165TA100	213663	A.154	RT2M	113726	A.71	SFK0E	120005	C.32	U201N02K2FS	167403	H.9
RSS20/165TA120	213664	A.154	RT2RA	114104	A.71	SFK0F	120006	C.32	U201N02K2SS	167414	H.9
RSS20/165TA150	215004	A.154	RT2RB	114132	A.71	SFK0G	120007	C.32	U203N00K4SS	167415	H.9
RSS20/165TA390	211748	A.154	RT2RC	114106	A.71	SFK0H	120008	C.32	U203N00K7SS	167416	H.9
RSS20/165TA470	211739	A.154	RT2RD	114133	A.71	SFK0I	120009	C.32	U203N01K5SS	167417	H.9
RSS20/165TA560	244987	A.154	RT2RE	114134	A.71	SFK0J	120010	C.32	U203N02K2SS	167418	H.9
RSS20/165TA82	214081	A.154	RT2RG	114109	A.71	SFK0K	120011	C.32	U203N04K0SS	167419	H.9
RT12D	139138	A.71	RT2RH	114146	A.71	SFK0L	120012	C.32	U203N05K5SS	167420	H.9
RT12F	139139	A.71	RT2RJ	114136	A.71	SFK0M	120013	C.32	U203N07K5SS	167422	H.9
RT12G	139140	A.71	RT2RL	114235	A.71	SFPE0	120053	C.34	U203X00K7FS	167404	H.9
RT12H	139141	A.71	RT2RM	114113	A.71	SFPR0	120052	C.34	U203X00K7SS	167424	H.9
RT12J	139142	A.71	RT2XP	113764	A.73	SFPS0	120051	C.34	U203X01K5FS	167405	H.9
RT12K	113640	A.71	RT32C	113657	A.72	SFS04	120040	C.34	U203X01K5SS	167425	H.9
RT12L	113641	A.71	RT32D	113658	A.72	SFS04K1	245217	C.34	U203X02K2FS	167406	H.9
RT12M	113642	A.71	RT32E	113659	A.72	SFS04M	212558	C.34	U203X02K2SS	167426	H.9
RT12N	113643	A.71	RT32F	113660	A.72	SFS05	120041	C.34	U203X04K0FS	167407	H.9
RT12P	113644	A.71	RT3B	113727	A.72	SFS05M	212559	C.34	U203X04K0SS	167427	H.9
RT12RD	114060	A.71	RT3C	113728	A.72	SFS0K2	120046	C.34	U203X05K5FS	167408	H.9
RT12RF	114061	A.71	RT3D	113729	A.72	SFV88	254537	C.13	U203X05K5SS	167428	H.9
RT12RG	114062	A.71	RT3E	113730	A.72	SFVCD	120054	C.34	U203X07K5FS	167409	H.9
RT12RH	114063	A.71	RT3F	113731	A.72	SFVH03	120050	C.33	U203X07K5SS	167429	H.9
RT12RJ	114159	A.71	RT3PXX3P	110565	A.73	SFVNO	101369	C.34	U203X11K0FS	167410	H.9
RT12RK	114114	A.71	RT4LA	113735	A.72	SKB-B250/220-4	212165	A.154	U203X11K0SS	167430	H.9
RT12RL	114115	A.71	RT4LB	113736	A.72	SKB-B30/08	211720	A.154	U203X15K0SS	167481	H.9
RT12RM	114116	A.71	RT4LC	113737	A.72	SKB-B500/445-4	214501	A.154	U203X18K0SS	167482	H.13
RT12RN	114117	A.71	RT4LD	113738	A.72	SKB-B80/70-4	211716	A.154	U203X18K0SS	167482	H.13
RT12RP	114118	A.71	RT4LE	113739	A.72	SON-3	123700	G.4	U203X18K5SS	167482	H.9
RT12RS	114119	A.71	RT4LF	113740	A.72	SPR	100549	B.12	U203X22K0SS	167483	H.9
RT12RT	114120	A.71	RT4LG	113741	A.72	T...			U203X22K0SS	167483	H.13
RT12RU	114121	A.71	RT4LH	113742	A.72	TLR100P200	108223	H.4	U203X30K0SS	167484	H.9
RT12RV	114122	A.71	RT4LJ	113743	A.72	TLR118P600	129174	H.13	U203X30K0SS	167484	H.13
RT12RW	114123	A.71	RT4LK	113744	A.72	TLR15P3700	129881	H.69	U203X37K0SS	167485	H.9
RT12S	113645	A.71	RT4LL	113745	A.72	TLR175P600	129173	H.13	U203X37K0SS	167485	H.13
RT12T	113646	A.71	RT4LM	113746	A.72	TLR200P200	129165	H.13	U203X45K0SS	167486	H.9
RT12U	113647	A.71	RT4LN	113747	A.72	TLR216P200	129868	H.68	U203X45K0SS	167486	H.13
RT12V	113648	A.71	RT4LP	113748	A.72	TLR22P2500	129879	H.13	U203X55K0SS	167487	H.9
RT12W	113649	A.71	RT4LR	113749	A.72	TLR22P600	129168	H.13	U203X55K0SS	167487	H.13
RT1B	113700	A.71	RT4N	113732	A.72	TLR240P200	108227	H.13	U20A ROK7	167087	H.4
RT1C	113701	A.71	RT4P	113733	A.72	TLR250P200	108227	H.4	U20AF0K7	167085	H.4
RT1D	113702	A.71	RT4R	113734	A.72	TLR295P200	129876	H.68	U20AF2K2	167086	H.4
RT1F	113703	A.71	RT5A	113750	A.72	TLR29P1800	129878	H.13	U20AF2K2X	167084	H.4
RT1G	113704	A.71	RT5B	113751	A.72	TLR29P600	129167	H.13	U20AROK7	167087	H.4
RT1H	113705	A.71	RT5C	113752	A.72	TLR35P1500	129877	H.13	U20NOK2P	167088	H.3
RT1J	113706	A.71	RT5D	113753	A.72	TLR35P3000	129888	H.69	U20NOK2PS	167132	H.3
RT1K	113707	A.71	RT5E	113754	A.72	TLR400P200	116302	H.4	U20NOK2S	167075	H.3
RT1L	113708	A.71	RT5LA	113755	A.72	TLR405P200	129867	H.69	U20NOK4P	167089	H.3
RT1M	113709	A.71	RT5LB	113756	A.72	TLR432P200	129875	H.69	U20NOK4PS	167133	H.3
RT1N	113710	A.71	RT5LC	113757	A.72	TLR43P1000	129177	H.13	U20NOK4S	167076	H.3
RT1P	113711	A.71	RT5LD	113758	A.72	TLR44P600	129166	H.13	U20NOK7P	167090	H.3
RT1RB	114087	A.71	RT5LE	113759	A.72	TLR4P3000	129872	H.69	U20NOK7PS	167134	H.3
RT1RC	114088	A.71	RT6A	113760	A.72	TLR59P1000	129176	H.68	U20NOK7S	167077	H.3
RT1RD	114089	A.71	RT6LA	113761	A.72	TLR5P2500	129871	H.69	U20N1K5P	167091	H.3
RT1RF	114090	A.71	RTMM 2 AU	124085	G.5	TLR74P200	129870	H.68	U20N1K5PS	167135	H.3
RT1RG	114091	A.71	RTMM 2 EN	124084	G.5	TLR750P200	116301	H.4	U20N1K5S	167078	H.3
RT1RH	114092	A.71	RTX3	113762	A.73	TLR75P200	116300	H.4	U20N2K2P	167092	H.3
RT1RJ	114093	A.71	RTXBS	108864	A.14	TLR8,8P1500	129171	H.69	U20N2K2PS	167136	H.3
RT1RK	114094	A.71	RTXP	105170	A.73	TLR86P600	129175	H.13	U20N2K2S	167079	H.3
RT1RL	114095	A.71	RTXRR		A.73	U...			U20X0K7P	167093	H.3
RT1RM	114096	A.71	RTXRRB	113661	A.14	U200ABK	167440	H.9	U20X0K7PS	167137	H.3
RT1RN	114097	A.71	RTXRRD	113662	A.14	U200ABU430	167468	H.9	U20X0K7S	167080	H.3
RT1RP	114098	A.71	RTXRRG	113663	A.14	U200ADN	167434	H.9	U20X1K5P	167094	H.3
RT1RS	114099	A.71	RTXRRJ	113664	A.14	U200ALCDK	167439	H.9	U20X1K5PS	167138	H.3
RT1RT	114100	A.71	RTXRRN	113665	A.14	U200ALEDK	167438	H.9	U20X1K5S	167081	H.3



Cat. no	Ref. no.	Page
U20X2K2P	167095	H.3
U20X2K2PS	167139	H.3
U20X2K2S	167082	H.3
V...		
V1107BA	113612	A.65
V1108B4	113505	A.65
V1108CA	113614	A.65
V1109B4	113899	A.65
V1109BA	113616	A.65
V1110CE	113618	A.65
V1111CE	113619	A.65
V1112BA	113620	A.65
V1113BA	113621	A.65
V1175CA	113613	A.65
V1185BA	113615	A.65
V1195BA	113617	A.65
V31203B	104743	A.58
V31204B	104745	A.58
V31205B	104747	A.58
V31206B	104749	A.58
V31207B	104750	A.58
V31208B	104752	A.58
V31209B	104754	A.58
V31210B	104755	A.58
V31245B	104758	A.58
VB1203B	133170	A.58
VB1204B	133885	A.58
VB1205B	104748	A.58
VB1207B	104751	A.58
VB1208B	104753	A.58
W...		
WKAT 35-1,2A/2V	204165	G.3
WKAT 35-10A/2V	204169	G.3
WKAT 70-1,2A/2V	204166	G.3
WKAT 70-10A/2V	204170	G.3
WKIO608	241752	A.60
WKIO910	241751	A.60
WKLE00	103238	A.60
WKLE02	103241	A.60
WKLE25	103243	A.60
WKLI02P	101422	A.60
WKLI04P	101424	A.60
WKLI07P	101426	A.60
WKLI25P	101423	A.60
WKLI45P	101425	A.60
WKMIU	101421	A.51
WLS0	103247	A.60
WLS01	241750	A.60

By catalogue number

Intro

B

B

C

D

E

F

G

H

I

J/X



By reference number

- Intro
- A
- B
- C
- D
- E
- F
- G
- H
- J/X

Ref. no	Cat. no	Page	Ref. no	Cat. no	Page	Ref. no	Cat. no	Page	Ref. no	Cat. no	Page
100000			101225	GPS1BSAR	C.3	101321	GPASLRAAJ	C.12	101417	GPF2L07AA	C.15
100470	MBOID	B.9	101226	GPS2BBSAK	C.5	101322	GPASLRAAM	C.12	101418	GPF1B1A	C.15
100471	MBOKD	B.9	101227	GPS2BSAM	C.5	101323	GPASLRAAN	C.12	101419	GPF2B2A	C.15
100513	MARL110AT	B.11	101228	GPS2BSAN	C.5	101324	GPASLRAAR	C.12	101420	GPF2B3A	C.15
100514	MARL101AT	B.11	101229	GPS2BSAP	C.5	101325	GPASLRAAU	C.12	101421	WKMIU	A.51
100515	MARL110AF	B.11	101230	GPS2BSAR	C.5	101326	GPASLRAAW	C.12	101422	WKLI02P	A.60
100516	MARL101AF	B.11	101231	GPS2BSAS	C.5	101327	GPASLRAAY	C.12	101423	WKLI25P	A.60
100517	MARL110AI	B.11	101232	GPS2BSAT	C.5	101328	GPASLRADD	C.12	101424	WKLI04P	A.60
100518	MARL101AI	B.11	101233	GPS2BSAU	C.5	101329	GPASLRADJ	C.12	101425	WKLI45P	A.60
100519	MARL110ATS	B.11	101234	GPS1BHAA	C.3	101330	GPAULRAAD	C.12	101426	WKLI07P	A.60
100520	MARL101ATS	B.11	101235	GPS1BHAB	C.3	101331	GPAULRAAC	C.12	101427	GPF1CBA	C.15
100521	MARL110AFS	B.11	101236	GPS1BHAC	C.3	101332	GPAULRAAG	C.12	101502	GPA2HAB	C.13
100522	MARL101AFS	B.11	101237	GPS1BHAD	C.3	101333	GPAULRAAF	C.12	101503	GPA2HAR	C.13
100523	MARL110AIS	B.11	101238	GPS1BHAE	C.3	101334	GPAULRAAJ	C.12	101509	GPAKS1A	C.12
100524	MARL101AIS	B.11	101239	GPS1BHAF	C.3	101335	GPAULRAAM	C.12	101511	GPB1GAF	C.13
100530	MCRIO40ATD	B.9	101240	GPS1BHAG	C.3	101336	GPAULRAAN	C.12	101512	GPF1L25CT1	C.15
100531	MCRIO31ATD	B.9	101241	GPS1BHAH	C.3	101337	GPAULRAAR	C.12	101513	GPF1L45CT1	C.15
100532	MCRIO22ATD	B.9	101242	GPS1BHAJ	C.3	101338	GPAULRAAU	C.12	101514	GPVDA	C.12
100533	MCRK040ATD	B.9	101243	GPS1BHAK	C.3	101339	GPAULRAAW	C.12	101515	GPVPA	C.12
100534	MCRK031ATD	B.9	101244	GPS1BHAL	C.3	101340	GPAULRAAY	C.12	101866	RE1D	A.75
100535	MCRK022ATD	B.9	101245	GPS1BHAM	C.3	101341	GPAU20LTAAD	C.12	101867	RE1H	A.75
100536	MPODAE4	B.12	101246	GPS1BHAN	C.3	101342	GPAU20LTAAC	C.12	101868	RE1K	A.75
100538	MC2I301ATD	A.46	101247	GPS1BHAP	C.3	101343	GPAU20LTAAG	C.12	101869	RE1M	A.75
100541	MREBC10AC2	B.12	101248	GPS1BHAR	C.3	101344	GPAU20LTAAF	C.12	101870	RE1S	A.75
100542	MREBC20AC2	B.12	101249	GPS2BHAK	C.5	101345	GPAU20LTAAJ	C.12	101871	RE1W	A.75
100543	MVB0R	B.12	101250	GPS2BHAM	C.5	101346	GPAU20LTAAM	C.12	101872	RE2H	A.75
100544	MPOAAE1	B.12	101251	GPS2BHAN	C.5	101347	GPAU20LTAAN	C.12	101873	RE2M	A.75
100545	MPOAAE2	B.12	101252	GPS2BHAP	C.5	101348	GPAU20LTAAR	C.12	101874	RE3E	A.75
100546	MPOCAE3	B.12	101253	GPS2BHAR	C.5	101349	GPAU20LTAAU	C.12	102000		
100547	MMHO	B.12	101254	GPS2BHAS	C.5	101350	GPAU20LTAAW	C.12	102625	GPAULRAA11	C.12
100548	EAT 260	B.12	101255	GPS2BHAT	C.5	101351	GPAU20LTAAY	C.12	103000		
100549	SPR	B.12	101256	GPS2BHAU	C.5	101352	GPAU20LCAAD	C.12	103238	WKLE00	A.60
100559	MC2I310ATD	A.46	101257	GPS1MSAA	C.7	101353	GPAU20LCAAC	C.12	103241	WKLE02	A.60
100560	MACL110AT	A.49	101258	GPS1MSAB	C.7	101354	GPAU20LCAAG	C.12	103243	WKLE25	A.60
100561	MACL101AT	A.49	101259	GPS1MSAC	C.7	101355	GPAU20LCAAF	C.12	103247	WLSD	A.60
100562	MACL110AF	A.49	101260	GPS1MSAD	C.7	101356	GPAU20LCAAJ	C.12	103298	MARL101ARS	B.11
100563	MACL101AF	A.49	101261	GPS1MSAE	C.7	101357	GPAU20LCAAM	C.12	103299	MARL110ARS	B.11
100564	MACL110AI	A.49	101262	GPS1MSAF	C.7	101358	GPAU20LCAAN	C.12	103300	MARN404AR	B.10
100565	MACL101AI	A.49	101263	GPS1MSAG	C.7	101359	GPAU20LCAAR	C.12	103349	MARN220AR	B.10
100572	MCI1310ATD	A.46	101264	GPS1MSAH	C.7	101360	GPAU20LCAAU	C.12	103350	MARN211AR	B.10
100573	MCI1301ATD	A.46	101265	GPS1MSAJ	C.7	101361	GPAU20LCAAV	C.12	103351	MARN202AR	B.10
100576	MCIK310ATD	A.46	101266	GPS1MSAK	C.7	101362	GPAU20LCAAY	C.12	103352	MARN440AR	B.10
100577	MCIK301ATD	A.46	101267	GPS1MSAL	C.7	101363	GPA1HAB	C.13	103353	MARN431AR	B.10
100600	MVPOC	A.50	101268	GPS1MSAM	C.7	101364	GPA1HAR	C.13	103354	MARN422AR	B.10
100608	MAGL110AT	A.51	101269	GPS1MSAN	C.7	101365	GPES41A	C.17	103355	MARN413AR	B.10
100885	LG2504P1B0	A.59	101270	GPS1MSAP	C.7	101366	GPES55A	C.17	103540	MT03RA	A.69
100987	MARN404AT	B.10	101271	GPS1MSAR	C.7	101367	GPEF41A	C.17	103541	MT03RB	A.69
100988	MARN413AT	B.10	101272	GPS2MSAK	C.9	101368	GPEF55A	C.17	103542	MT03RC	A.69
100989	MARN422AT	B.10	101273	GPS2MSAM	C.9	101369	GPENA	C.17	103543	MT03RD	A.69
100990	MARN431AT	B.10	101274	GPS2MSAN	C.9	101370	GPEPA	C.17	103544	MT03RE	A.69
100991	MARN440AT	B.10	101275	GPS2MSAP	C.9	101371	GPECA	C.17	103545	MT03RF	A.69
100992	MARN202AT	B.10	101276	GPS2MSAR	C.9	101372	GPEPMA	C.17	103546	MT03RG	A.69
100993	MARN211AT	B.10	101277	GPS2MSAS	C.9	101373	GPEPLA	C.17	103547	MT03RH	A.69
100994	MARN220AT	B.10	101278	GPS2MSAT	C.9	101374	GPEPKA	C.17	103548	MT03RI	A.69
100995	MACN413AT	A.48	101279	GPS2MSAU	C.9	101375	GPELGAJ	C.17	103549	MT03RJ	A.69
100996	MACN422AT	A.48	101280	GPS1MHAH	C.7	101376	GPELGAN	C.17	103550	MT03RK	A.69
100997	MACN431AT	A.48	101281	GPS1MHAB	C.7	101377	GPELGAU	C.17	103551	MT03RL	A.69
100998	MACN202AT	A.48	101282	GPS1MHAC	C.7	101378	GPELGAX	C.17	103552	MT03RM	A.69
100999	MACN211AT	A.48	101283	GPS1MHAD	C.7	101379	GPELGAY	C.17	103553	MT03RN	A.69
101000			101284	GPS1MHAE	C.7	101380	GPELRAJ	C.17	103554	MT03RP	A.69
101000	MT03A	A.69	101285	GPS1Mhaf	C.7	101381	GPELRAN	C.17	103555	MACL110AR	A.49
101001	MT03B	A.69	101286	GPS1MHAF	C.7	101382	GPELRAU	C.17	103556	MARL110AR	B.11
101002	MT03C	A.69	101287	GPS1MHAH	C.7	101383	GPELRAX	C.17	103557	MARL101AR	B.11
101003	MT03D	A.69	101288	GPS1MHAJ	C.7	101384	GPELRAY	C.17	103558	MACN202AR	A.48
101004	MT03E	A.69	101289	GPS1MHAH	C.7	101385	GPELCAJ	C.17	103559	MACN431AR	A.48
101005	MT03F	A.69	101290	GPS1MHAL	C.7	101386	GPELCAN	C.17	103560	MACN422AR	A.48
101006	MT03G	A.69	101291	GPS1MHAM	C.7	101387	GPELCAU	C.17	103561	MACN413AR	A.48
101007	MT03H	A.69	101292	GPS1MHAN	C.7	101388	GPELCAX	C.17	103562	MVEOR	A.69
101008	MT03I	A.69	101293	GPS1MHAP	C.7	101389	GPELCAY	C.17	103563	MATV10AR	A.69
101009	MT03J	A.69	101294	GPS1MHAR	C.7	101390	GPB1B02A	C.13	103590	MC2K310ATD	A.46
101010	MT03K	A.69	101295	GPS2MHAK	C.9	101391	GPB1B03A	C.13	103591	MC2K301ATD	A.46
101011	MT03L	A.69	101296	GPS2MHAM	C.9	101392	GPB1B04A	C.13	103747	PTPCK75	A.65
101012	MT03M	A.69	101297	GPS2MHAN	C.9	101393	GPB1B05A	C.13	103748	PTPCK95	A.65
101013	MT03N	A.69	101298	GPS2MHAP	C.9	101394	GPB1B12A	C.13	103749	PTPCK11	A.65
101014	MT03P	A.69	101299	GPS2MHAR	C.9	101395	GPB1B13A	C.13	104000		
101015	MT03R	A.69	101300	GPS2MHAS	C.9	101396	GPB1B14A	C.13	104587	KVB12E	A.67
101017	SBELA	A.57	101301	GPS2MHAT	C.9	101397	GPB1B15A	C.13	104597	KVB10E	A.67
101020	MVE0T	A.69	101302	GPS2MHAU	C.9	101398	GPB1B22A	C.13	104690	KVB75I	A.66
101021	MVB0T	A.69	101303	GPAC10FBA	C.11	101399	GPB1B24A	C.13	104691	KVB95I	A.66
101022	MATV10AT	A.69	101304	GPAC01FBA	C.11	101400	GPB2B02A	C.13	104692	KVB10I	A.66
101095	LG2506P1B0	A.59	101305	GPAC11LLA	C.11	101401	GPB2B03A	C.13	104693	KVB12I	A.66
101194	GPASLRAA11	C.12	101306	GPAC20LLA	C.11	101402	GPB2B04A	C.13	104694	KVB75E	A.67
101211	GPS1BSAA	C.3	101307	GPAC02LLA	C.11	101403	GPB2B12A	C.13	104695	KVB95E	A.67
101212	GPS1BSAB	C.3	101308	GPAC11LRA	C.11	101404	GPB2B13A	C.13	104700	BCLF10	B.15
101213	GPS1BSAC	C.3	101309	GPAC20LRA	C.11	101405	GPB2B14A	C.13	104701	BCLF01	B.15
101214	GPS1BSAD	C.3	101310	GPAC02LRA	C.11	101406	GPB2B22A	C.13	104702	BCLF10G	B.15
101215	GPS1BSAE	C.3	101311	GPAL10FRA	C.11	101407	GPB2B24A	C.13	104703	BCLF01G	B.15
101216	GPS1BSAF	C.3	101312	GPAL01FRA	C.11	101408	GPB1GA	C.13	104704	BRL20	B.15
101217	GPS1BSAG	C.3	101313	GPAD1010LLA	C.11	101409	GPB2GA	C.13	104705	BRL11	B.15
101218	GPS1BSAH	C.3	101314	GPAD1001LLA	C.11	101410	GPB1LMCBA	C.15	104706	BCLL20	A.57
101219	GPS1BSAJ	C.3	101315	GPAD0110LLA	C.11	101411	GPF1L02AA	C.15	104707	BCLL11	A.57
101220	GPS1BSAK	C.3	101316	GPAD0101LLA	C.11	101412	GPF1L02DA	C.15	104709	BTLF30C	B.15
101221	GPS1BSAL	C.3	101317	GPAE11LLA	C.11	101413	GPF1L25AA	C.15	104710	BTLF60C	B.15
101222	GPS1BSAM	C.3	101318	GPASLRAA1	C.12	101414	GPF1L25DA	C.15	104711	BTLF30D	B.15
101223	GPS1BSAN	C.3	101319	GPASLRAAF	C.12	101415	GPF2L45AA	C.15	104712	BTLF60D	B.15
101224	GPS1BSAP	C.3	101320	GPASLRAAG	C.12	101416	GPF2L45DA	C.15	104713	BSLR2G	B.16



Ref. no	Cat. no	Page	Ref. no	Cat. no	Page	Ref. no	Cat. no	Page	Ref. no	Cat. no	Page
104714	BSLR2K	B.16	113614	V1108CA	A.65	113755	RT5LA	A.72	118000		
104715	BSLR2R	B.16	113615	V1185BA	A.65	113756	RT5LB	A.72	118846	P9ARTAPN028	F.32
104716	BSLR3G	A.58	113616	V1109BA	A.65	113757	RT5LC	A.72	120000		
104717	BSLR3K	A.58	113617	V1195BA	A.65	113758	RT5LD	A.72	120001	SFK0A	C.32
104718	BSLR3R	A.58	113618	V1110CE	A.65	113759	RT5LE	A.72	120002	SFK0B	C.32
104719	BSLDZ	B.16	113619	V1111CE	A.65	113760	RT6A	A.72	120003	SFK0C	C.32
104720	BSLV3G	B.16	113620	V1112BA	A.65	113761	RT6LA	A.72	120004	SFK0D	C.32
104721	BSLV3K	B.16	113621	V1113BA	A.65	113762	RTX3	A.73	120005	SFK0E	C.32
104722	BSLV3R	B.16	113627	KVP75U	A.66	113764	RT2XP	A.73	120006	SFK0F	C.32
104723	BELA	B.16	113628	KVP85U	A.66	113850	PTP04	A.58	120007	SFK0G	C.32
104724	BELA02	B.16	113630	KVP12U	A.66	113851	PTP45	A.58	120008	SFK0H	C.32
104743	V31203B	A.58	113631	KVP85I	A.66	113852	PTP08	A.58	120009	SFK0I	C.32
104745	V31204B	A.58	113633	KVP12I	A.66	113853	PTP10	A.58	120010	SFK0J	C.32
104747	V31205B	A.58	113637	KVP95E	A.67	113855	RTXS	A.14	120011	SFK0K	C.32
104748	VB1205B	A.58	113640	RT12K	A.71	113856	RTXSL	A.14	120012	SFK0L	C.32
104749	V31206B	A.58	113641	RT12L	A.71	113899	V1109B4	A.65	120013	SFK0M	C.32
104750	V31207B	A.58	113642	RT12M	A.71	114000			120020	SFAL11N	C.33
104751	VB1207B	A.58	113643	RT12N	A.71	114060	RT12RD	A.71	120021	SFAL20N	C.33
104752	V31208B	A.58	113644	RT12P	A.71	114061	RT12RF	A.71	120022	SFAL11D	C.33
104753	VB1208B	A.58	113645	RT12S	A.71	114062	RT12RG	A.71	120023	SFAL20D	C.33
104754	V31209B	A.58	113646	RT12T	A.71	114063	RT12RH	A.71	120024	SFAL11	C.33
104755	V31210B	A.58	113647	RT12U	A.71	114087	RT1RB	A.71	120025	SFAK10	C.33
104758	V31245B	A.58	113648	RT12V	A.71	114088	RT1RC	A.71	120026	SFAK01	C.33
104760	KRC24	A.65	113649	RT12W	A.71	114089	RT1RD	A.71	120027	SFAL11S	C.33
104761	KRC48/260	A.65	113650	RT22D	A.71	114090	RT1RF	A.71	120030	SFB0AJ	C.33
104762	KRC380/415	A.65	113651	RT22E	A.71	114091	RT1RG	A.71	120031	SFB0AN	C.33
104763	BEKH	A.65	113652	RT22G	A.71	114092	RT1RH	A.71	120032	SFB0AU	C.33
104764	BEKV	A.65	113653	RT22H	A.71	114093	RT1RJ	A.71	120034	SFB0RJ	C.33
104766	C09476	A.65	113654	RT22J	A.71	114094	RT1RK	A.71	120035	SFB0RN	C.33
104767	KVP12G	A.66	113655	RT22L	A.71	114095	RT1RL	A.71	120036	SFB0RU	C.33
104770	KVP85G	A.66	113656	RT22M	A.71	114096	RT1RM	A.71	120040	SFS04	C.34
104771	KVP10G	A.66	113657	RT32C	A.72	114097	RT1RN	A.71	120041	SFS05	C.34
104785	BEKVA 1	A.65	113658	RT32D	A.72	114098	RT1RP	A.71	120042	SFE04	C.34
104786	BEKVS 1	A.65	113659	RT32E	A.72	114099	RT1RS	A.71	120043	SFE05	C.34
104797	BNL	A.59	113660	RT32F	A.72	114100	RT1RT	A.71	120046	SFS0K2	C.34
104798	EPL	A.59	113661	RTXRRB	A.14	114101	RT1RU	A.71	120047	SFE0K2	C.34
104800	BMLF	A.59	113662	RTXRRD	A.14	114102	RT1RV	A.71	120050	SFVH03	C.33
105000			113663	RTXRRG	A.14	114103	RT1RW	A.71	120051	SFPS0	C.34
105170	RTXP	A.73	113664	RTXRRJ	A.14	114104	RT2RA	A.71	120052	SFPRO	C.34
105200	CM1CASF	A.65	113665	RTXRRN	A.14	114106	RT2RC	A.71	120053	SFPE0	C.34
106000			113666	RTXRRU	A.14	114109	RT2RG	A.71	120054	SFVCD	C.34
106622	BRLL02	B.15	113700	RT1B	A.71	114113	RT2RM	A.71	120114	SFB0RNM	C.33
107000			113701	RT1C	A.71	114114	RT12RK	A.71	120115	SFB0RUM	C.33
107097	GPEUTA	C.17	113702	RT1D	A.71	114115	RT12RL	A.71	120881	QA02P008S	I.3
107098	GPFO0C02	C.15	113703	RT1F	A.71	114116	RT12RM	A.71	120882	QA02P017S	I.3
107099	GPFI0C02	C.15	113704	RT1G	A.71	114117	RT12RN	A.71	120883	QA02P022S	I.3
107100	GPFO1C02	C.15	113705	RT1H	A.71	114118	RT12RP	A.71	120884	QA02P031S	I.3
107101	GPFO0C25	C.15	113706	RT1J	A.71	114119	RT12RS	A.71	120885	QA02P044S	I.3
107102	GPFO0C04	C.15	113707	RT1K	A.71	114120	RT12RT	A.71	120886	QA02P058S	I.3
107103	GPFI0C04	C.15	113708	RT1L	A.71	114121	RT12RU	A.71	120892	QA12P008S	I.3
107105	GPFO1C04	C.15	113709	RT1M	A.71	114122	RT12RV	A.71	120893	QA12P017S	I.3
107106	GPFO0C45	C.15	113710	RT1N	A.71	114123	RT12RW	A.71	120894	QA12P022S	I.3
107107	GPFO0C08	C.15	113711	RT1P	A.71	114124	RT22RD	A.71	120895	QA12P031S	I.3
107119	GPS2BSAL	C.5	113712	RT1S	A.71	114126	RT22RG	A.71	120896	QA12P044S	I.3
107120	GPS2BHAL	C.5	113713	RT1T	A.71	114127	RT22RH	A.71	120897	QA12P058S	I.3
107121	GPS2MSAL	C.9	113714	RT1U	A.71	114128	RT22RJ	A.71	120898	QA22P008S	I.3
107122	GPS2MHAL	C.9	113715	RT1V	A.71	114130	RT22RM	A.71	120899	QA22P017S	I.3
107152	PBF23EBDA	A.13	113716	RT1W	A.71	114132	RT2RB	A.71	120900	QA22P022S	I.3
107153	PBF23ECDA	A.13	113717	RT2A	A.71	114133	RT2RD	A.71	120901	QA22P031S	I.3
107163	GPF1B4A	C.15	113718	RT2B	A.71	114134	RT2RE	A.71	120902	QA22P044S	I.3
107165	GPF1L04AA	C.15	113719	RT2C	A.71	114136	RT2RJ	A.71	120903	QA22P058S	I.3
107166	GPF1L04DA	C.15	113720	RT2D	A.71	114141	RT22RE	A.71	120904	QA32P008S	I.3
107182	GPAPT2A	C.12	113721	RT2E	A.71	114143	RT22RL	A.71	120905	QA32P017S	I.3
107186	GPB1FA	C.13	113722	RT2G	A.71	114146	RT2RH	A.71	120906	QA32P022S	I.3
107187	GPB2FA	C.13	113723	RT2H	A.71	114159	RT12RJ	A.71	120907	QA32P031S	I.3
107190	GPF2L04AA	C.15	113724	RT2J	A.71	114235	RT2RL	A.71	120908	QA32P044S	I.3
107191	GPF2L04DA	C.15	113725	RT2L	A.71	116000			120909	QA32P058S	I.3
107252	GPFL09AA	C.15	113726	RT2M	A.71	116011	LG0006S1B0	A.59	120910	QA0PTDIN	I.3
107253	GPFL3B5A	C.15	113727	RT3B	A.72	116074	MG0006QATO	A.51	123000		
107256	SFB0RJM	C.33	113728	RT3C	A.72	116099	P9ARTAPN	F.32	123623	RCRT 6 - 60AJ	G.3
107315	GPAPT1E	C.13	113729	RT3D	A.72	116113	N211B	F.69	123624	RCRT 6 - 60AN	G.3
108000			113730	RT3E	A.72	116140	P9ARTAPN039	F.32	123656	DINIL 02E 2EN	G.4
108223	TLR100P200	H.4	113731	RT3F	A.72	116141	P9ARTAPN042	F.32	123700	SON-3	G.4
108227	TLR250P200	H.4	113732	RT4N	A.72	116143	P9ARTAPN201	F.32	123744	RDHT 1-1.2AEN	G.3
108864	RTXBS	A.14	113733	RT4P	A.72	116144	P9ARTAPN202	F.32	123754	RDHT 1-10AEN	G.3
108901	BCRF10	B.15	113734	RT4R	A.72	116145	P9ARTAPN206	F.32	123964	RDHA 1-10AEN	G.3
108902	BCRF01	B.15	113735	RT4LA	A.72	116147	P9ARTAPN212	F.32	123965	RDHA 1-1.2AEU	G.3
108903	BTRF30C	B.15	113736	RT4LB	A.72	116148	P9ARTAPN213	F.32	123985	RDF1-50AU	G.5
108904	BTRF60C	B.15	113737	RT4LC	A.72	116150	P9ARTAPN291	F.32	124000		
108905	BTRF30D	B.15	113738	RT4LD	A.72	116212	KVPO8E	A.67	124025	RPDF2-50AU	G.5
108906	BTRF60D	B.15	113739	RT4LE	A.72	116226	LG2504R1B0	A.59	124051	RSF1-50ANU	G.5
110000			113740	RT4LF	A.72	116235	KVP12E	A.67	124084	RTMM 2 EN	G.5
110360	GPALU20LTAA11	C.12	113741	RT4LG	A.72	116300	TLR75P200	H.4	124085	RTMM 2 AU	G.5
110565	RT3PXX3P	A.73	113742	RT4LH	A.72	116301	TLR750P200	H.4	124104	RMM 2 EN	G.5
110836	BSLV3U	B.16	113743	RT4LJ	A.72	116302	TLR400P200	H.4	124184	RDIT2400VEN	G.4
112000			113744	RT4LK	A.72	116402	MG0006GRATO	A.51	124354	RDIT2-02VEN	G.4
112185	GPALU20LCAA11	C.12	113745	RT4LL	A.72	116651	LG0004R1B0	A.59	124373	RS01NAJ	G.4
113000			113746	RT4LM	A.72	116652	LG0006R1B0	A.59	124433	RCF-1 AJ	G.4
113001	BTLFX	B.15	113747	RT4LN	A.72	116653	LG0404P1B0	A.59	124434	RCF-1 EN	G.4
113505	V1108B4	A.65	113748	RT4LP	A.72	116656	LG0406P1B0	A.59	124435	RCF-1 AU	G.4
113602	BETL02C	B.16	113749	RT4LR	A.72	116663	NA11B	F.69	124622	RSFF1-50AU	G.5
113603	BETL45C	B.16	113750	RT5A	A.72	116664	N222B	F.69	124754	RDIT2-5AEN	G.4
113604	BETL02D	B.16	113751	RT5B	A.72	116665	N422B	F.69	124901	NMTCV 2	G.2
113605	BETL45D	B.16	113752	RT5C	A.72	116991	P9ARTAPN040	F.32	124908	NMETV	G.2
113612	V1107BA	A.65	113753	RT5D	A.72	116996	LG0404S1B0	A.59	124911	NMETV t AU	G.2
113613	V1175CA	A.65	113754	RT5E	A.72	116997	LG0406S1B0	A.59	124915	NMRDV 2-6	G.2

By reference number

Intro

B

B

C

D

E

F

G

H

I

J/X





Ref. no	Cat. no	Page	Ref. no	Cat. no	Page	Ref. no	Cat. no	Page	Ref. no	Cat. no	Page
124916	NMRDV 2-60	G.2	137000			167408	U203X05K5FS	H.9	168543	DCRP45A0H55	H.13
124917	NMRDV 2-600	G.2	137566	MG0004QATO	A.51	167409	U203X07K5FS	H.9	168555	DCRP18A2H9	H.13
124929	NMIVV	G.2	137567	MG0004RATO	A.51	167410	U203X11K0FS	H.9	168556	DCRP25A2H1	H.13
124930	NMMFV	G.2	139000			167411	U201N00K4SS	H.9	168557	DCRP32A1H6	H.13
129000			139138	RT12D	A.71	167412	U201N00K7SS	H.9	169000		
129165	TLR200P200	H.13	139139	RT12F	A.71	167413	U201N01K5SS	H.9	169075	QT10008U21MS	1.8
129166	TLR44P600	H.13	139140	RT12G	A.71	167414	U201N02K2SS	H.9	169076	QT10017U21MS	1.8
129167	TLR29P600	H.13	139141	RT12H	A.71	167415	U203N00K4SS	H.9	169077	QT10031U21MS	1.8
129168	TLR22P600	H.13	139142	RT12J	A.71	167416	U203N00K7SS	H.9	169078	QT10044U21MS	1.8
129171	TLR8.8P1500	H.69	150000			167417	U203N01K5SS	H.9	169079	QT10058U21MS	1.8
129173	TLR175P600	H.13	150775	P9XER50775	F.8	167418	U203N02K2SS	H.9	169080	QT10072U21MS	1.8
129174	TLR118P600	H.13	150776	P9XERW50776	F.8	167419	U203N04K0SS	H.9	169081	QT10085U21MS	1.8
129175	TLR86P600	H.13	150777	P9XEC50777	F.8	167420	U203N05K5SS	H.9	169082	QT10105U21MS	1.8
129176	TLR59P1000	H.68	152000			167422	U203N07K5SS	H.9	169083	QT10145U21MS	1.8
129177	TLR43P1000	H.13	152002	P9XPN52002	F.8	167424	U203X00K7SS	H.9	169084	QT10170U21MS	1.8
129867	TLR405P200	H.69	152007	P9XPN52007	F.8	167425	U203X01K5SS	H.9	169085	QT10210U21MS	1.9
129868	TLR216P200	H.68	152061	P9XPN52061	F.8	167426	U203X02K2SS	H.9	169086	QT10310U21MS	1.9
129870	TLR74P200	H.68	152111	P9XEM52111	F.8	167427	U203X04K0SS	H.9	169087	QT10390U21MS	1.9
129871	TLR5P2500	H.69	152121	P9XET52121	F.8	167428	U203X05K5SS	H.9	169088	QT10460U21MS	1.9
129872	TLR4P3000	H.69	152293	P9XSM52293	F.8	167429	U203X07K5SS	H.9	169089	QT10580U21MS	1.8
129875	TLR432P200	H.69	152321	P9XSM52321	F.8	167430	U203X11K0SS	H.9	169090	QT10820U21MS	1.8
129876	TLR295P200	H.68	152434	P9XSC52434	F.8	167433	U200APB	H.9	169091	QT10210N21MS	1.8
129877	TLR35P1500	H.13	152435	P9XSC52435	F.8	167434	U200ADN	H.9	169092	QT10310N21MS	1.8
129878	TLR29P1800	H.13	152496	P9XSC52496	F.8	167435	U200ARS485	H.9	169093	QT10390N21MS	1.8
129879	TLR22P2500	H.13	152497	P9XSC52497	F.8	167436	U200ARS232	H.9	169094	QT10460N21MS	1.8
129881	TLR15P3700	H.69	152502	P9XPL52502	F.9	167437	U200AMP	H.9	169095	QT10580N21MS	1.8
129888	TLR35P3000	H.69	152511	P9XPL52511	F.9	167438	U200ALEDK	H.9	169096	QT10650N21MS	1.8
130000			152513	P9XPL52513	F.9	167439	U200ALCDK	H.9	169097	QT10950N21MS	1.8
130057	IUGU-B211 S	G.25	152514	P9XPL52514	F.9	167440	U200ABK	H.9	169098	QT11100N21MS	1.8
130060	IUGA-B211	G.25	152515	P9XPL52515	F.9	167441	U200AW05	H.9	169099	QT11400N21MS	1.8
130082	IUGA-B411	G.25	152610	P9XLD52610	F.9	167442	U200AW10	H.9	169100	QT20008U21MS	1.9
130084	IUGU-B411	G.25	152611	P9XLD52611	F.9	167443	U200AW20	H.9	169101	QT20017U21MS	1.9
130086	IUGR-B411	G.25	152620	P9XLD52620	F.9	167444	U200AW30	H.9	169102	QT20031U21MS	1.9
130088	IUGH-B411	G.25	152621	P9XLD52621	F.9	167445	U200AW50	H.9	169103	QT20044U21MS	1.9
130090	IUGI-B411	G.25	153000			167446	U200AN101	H.9	169104	QT20058U21MS	1.9
130094	IUGE-B411	G.25	153006	P9MPN53006	F.8	167447	U200AN102	H.9	169105	QT20072U21MS	1.9
130096	IUGL-B411	G.25	153007	P9MPN53007	F.8	167448	U200AN103	H.9	169106	QT20085U21MS	1.9
130098	IUGT-B311	G.25	153061	P9MPN53061	F.8	167453	U200F611TA1	H.14	169107	QT20105U21MS	1.9
130100	IUGP-B311	G.25	153111	P9MEM53111	F.8	167454	U200F627TA2	H.14	169108	QT20145U21MS	1.9
130102	IUGQ-B311	G.25	153121	P9MET53121	F.8	167456	U200F709TA1	H.14	169109	QT20170U21MS	1.9
130104	IUGM-B311	G.25	153293	P9MSM53293	F.8	167457	U200F719TA2	H.14	169110	QT20210U21MS	1.9
130144	I2MA-B311	G.26	153391	P9MSM53391	F.8	167458	U200F739TA3	H.14	169111	QT20310U21MS	1.9
130145	I2MS-B311	G.26	153435	P9MSC53435	F.8	167459	U200F905TA1	H.14	169112	QT20390U21MS	1.9
130146	I2MR-B311	G.26	153497	P9MSC53497	F.8	167460	U200F910TA2	H.14	169113	QT20460U21MS	1.9
130310	090MI1	G.38	153502	P9MPL53502	F.9	167461	U200F928TA3	H.14	169114	QT20580U21MS	1.9
130311	090MI2	G.38	153511	P9MPL53511	F.9	167468	U200ABU430	H.9	169115	QT20820U21MS	1.9
130320	114FCT03	G.29	153513	P9MPL53513	F.9	167474	U200F34048SMA	H.14	169119	QT30008N21MS	1.8
130321	114FCT03T	G.29	153514	P9MPL53514	F.9	167475	U200F370A	H.14	169120	QT30017N21MS	1.8
132000			153515	P9MPL53515	F.9	167476	U200F3100A	H.14	169121	QT30031N21MS	1.8
132170	IPAI-N211B	F.69	153610	P9MLD53610	F.9	167477	U200F3150A	H.14	169122	QT30044N21MS	1.8
132172	IPBI-N211B	F.69	153611	P9MLD53611	F.9	167478	U200F3180A	H.14	169123	QT30058N21MS	1.8
132186	IPBI-N222B	F.69	153621	P9MLD53621	F.9	167481	U203X15K0SS	H.9	169124	QT30072N21MS	1.8
132198	IPAI-N411B	F.69	153623	P9MLD53620	F.9	167482	U203X18K5SS	H.9	169125	QT30085N21MS	1.8
132201	IPBI-N411B	F.69	154000			167483	U203X22K0SS	H.9	169126	QT30105N21MS	1.8
132203	IPBI-R411B	F.69	154700	P9DPL54700	F.9	167484	U203X30K0SS	H.9	169127	QT30145N21MS	1.8
132213	IPAI-N422B	F.69	154701	P9DPL54701	F.9	167485	U203X37K0SS	H.9	169128	QT30170N21MS	1.8
132215	IPBI-N422B	F.69	154720	P9DPL54720	F.9	167486	U203X45K0SS	H.9	169129	QT30210N21MS	1.8
132216	IPBI-D422B	F.69	154721	P9DPL54721	F.9	167487	U203X55K0SS	H.9	169130	QT30310N21MS	1.8
132230	105DTL220	F.58	167000			168000			169131	QT30390N21MS	1.8
132231	105DTL500	F.58	167075	U20N0K2S	H.3	168387	DCR4A5H7	H.13	169132	QT30460N21MS	1.8
132232	105DTL690	F.58	167076	U20N0K4S	H.3	168388	DCR6A3H9	H.13	169133	QT30580N21MS	1.8
132234	105PT	G.29	167077	U20N0K7S	H.3	168389	DCR9A2H4	H.13	169134	QT30650N21MS	1.8
132240	105 GIL	F.59	167078	U20N1K5S	H.3	168390	DCR12A1H7	H.13	169135	QT30950N21MS	1.8
132241	105 GIL 10	F.59	167079	U20N2K2S	H.3	168391	DCR18A1H0	H.13	169136	QT31100N21MS	1.8
132242	105 CI	F.59	167080	U20X0K7S	H.3	168392	DCR3A15H2	H.13	169137	QT31400N21MS	1.8
132243	105 CI 10	F.59	167081	U20X1K5S	H.3	168393	DCR4A9H2	H.13	170000		
132244	105 PM	F.59	167082	U20X2K2S	H.3	168394	DCR6A6H8	H.13	170212	080ESL	F.30
132250	105GP1P220	F.58	167084	U20AF2K2X	H.4	168395	DCR9A4H0	H.13	170801	080SP1	F.27
132251	105GP1P220M	F.58	167085	U20AF0K7	H.4	168490	ACRP3A7H0	H.4	170802	080SP2	F.27
132252	105GP1P500	F.58	167086	U20AF2K2	H.4	168491	ACRP8A2H5	H.4	170803	080SP3	F.27
132253	105GP1P500M	F.58	167087	U20A ROK7	H.4	168492	ACRP12A2H5	H.4	170804	080SP4	F.27
132500	115PC002	G.38	167088	U20N0K2P	H.3	168493	ACRP18A1H3	H.4	170806	080SP6	F.27
132501	115PC015	G.38	167089	U20N0K4P	H.3	168494	ACRP22A0H84	H.4	170807	080SP8	F.27
132502	115PC018	G.38	167090	U20N0K7P	H.3	168495	ACRP4A2H5	H.13	170808	080SP12	F.27
132503	115PC119	G.38	167091	U20N1K5P	H.3	168496	ACRP6A2H5	H.4	170809	080SP18	F.27
132505	115PC2015	G.38	167092	U20N2K2P	H.3	168497	ACRP9A1H3	H.4	170810	080SP24	F.27
132515	115PC2018	G.38	167093	U20X0K7P	H.3	168498	ACRP12A0H84	H.13	170811	080SP35	F.27
132517	115PC2015A	G.38	167094	U20X1K5P	H.3	168499	ACRP18A0H56	H.13	170831	080SP1M	F.27
132562	115807SP	G.38	167095	U20X2K2P	H.3	168500	ACRP27A0H37	H.13	170832	080SP2M	F.27
132563	115803SP	G.38	167132	U20N0K2PS	H.3	168501	ACRP35A0H27	H.13	170834	080SP4M	F.27
132564	115805SP	G.38	167133	U20N0K4PS	H.3	168509	ACRP3A8H1	H.4	170835	080SP1SFC	F.27
132565	115804SP	G.38	167134	U20N0K7PS	H.3	168510	ACRP4A5H1	H.4	170836	080SP1SFE	F.27
132571	115CA	G.38	167135	U20N1K5PS	H.3	168511	ACRP6A3H4	H.4	170837	080SP1SF	F.27
133000			167136	U20N2K2PS	H.3	168512	ACRP10A2H	H.13	170838	080SP1MSFC	F.27
133170	VB1203B	A.58	167137	U20X0K7PS	H.3	168513	ACRP14A1H4	H.13	170839	080SP1MSFE	F.27
133264	LG0404R1B0	A.59	167138	U20X1K5PS	H.3	168514	ACRP18A1H1	H.13	170840	080SP1MSF	F.27
133265	LG0406R1B0	A.59	167139	U20X2K2PS	H.3	168515	ACRP27A0H75	H.13	170841	080SP2SFC	F.27
133370	KVP75I	A.66	167400	U201N00K4FS	H.9	168516	ACRP35A0H58	H.13	170842	080SP2SFE	F.27
133371	KVP10I	A.66	167401	U201N00K7FS	H.9	168517	ACRP38A0H58	H.13	170843	080SP2SF	F.27
133374	KVP10U	A.66	167402	U201N01K5FS	H.9	168518	ACRP45A0H45	H.13	170844	080SP2MSFC	F.27
133378	KVP75E	A.67	167403	U201N02K2FS	H.9	168519	ACRP70A0H29	H.13	170845	080SP2MSFE	F.27
133379	KVP85E	A.67	167404	U203X00K7FS	H.9	168520	ACRP90A0H22	H.13	170846	080SP2MSF	F.27
133380	KVP10E	A.67	167405	U203X01K5FS	H.9	168521	ACRP115A0H18	H.13	170847	080SP3SFC	F.27
133611	LG2506R1B0	A.59	167406	U203X02K2FS	H.9	168522	ACRP				

Ref. no	Cat. no	Page	Ref. no	Cat. no	Page	Ref. no	Cat. no	Page	Ref. no	Cat. no	Page
170850	080SP4SFE	F.27	180524	077SP2M	F.52	181609	077PTB01	F.51	186072	P9SER4RA	F.11
170851	080SP4MSFE	F.27	180525	077SP3	F.52	181615	077PTB11	F.51	186073	P9SEC4RA95	F.11
170852	080SP6SFE	F.27	180526	077SP4V	F.52	181620	077GE35	F.50	186110	P9SSMD0N	F.12
170853	080SP8SFC	F.27	180527	077SP4	F.52	181650	077TGR	F.51	186120	P9SSMION	F.12
170854	080SP8SFE	F.27	180528	077SP6	F.52	181660	077TNA	F.51	186140	P9SSMD5N	F.12
170855	080SP8SF	F.27	180529	077SP9	F.52	181670	077TNA2	F.51	186150	P9SSMISN	F.12
170856	080SP12SFC	F.27	180530	077SP12	F.52	181720	077TNA312	F.51	186170	P9SSMEON	F.12
170857	080SP12SFE	F.27	180531	077SP16	F.52	181722	077TNA313	F.51	186190	P9SSMU0N	F.12
170858	080SP12SF	F.27	180532	077SP20	F.52	181840	077TGRO2	F.51	186200	P9SSMZ0N	F.12
170859	080SP18SFC	F.27	180533	077SP25	F.52	181930	077TNA40	F.51	186210	P9SSME1N	F.12
170860	080SP18SFE	F.27	180534	077SP30	F.52	181951	077TNA230	F.51	186230	P9SSMU1N	F.12
170861	080SP18SF	F.27	180535	077SP36	F.52	181962	077TNA3	F.51	186240	P9SSMZ1N	F.12
170862	080SP24SFE	F.27	180536	077SP1SFE	F.52	181963	077TNA301	F.51	186280	P9SSMZ5N	F.12
170863	080SP35SFC	F.27	180537	077SP1MSFE	F.52	184000			186320	P9SSMZ3N	F.12
170864	080SP35SFE	F.27	180538	077SP2SFE	F.52	184070	P9MER3RN	F.11	186330	P9SSMX0N	F.12
170865	080SP35SF	F.27	180539	077SP2MSFE	F.52	184071	P9MER4RN	F.11	186400	P9SSC0A95	F.14
170883	080KCSF	F.27	180540	077SP3SFE	F.52	184690	P9MPS21G	F.17	186409	P9SSC05A95	F.14
173000			180541	077SP4VSFE	F.52	184691	P9MPS22G	F.17	186410	P9SSC095	F.14
173033	077CF73033	F.31	180542	077SP4SFE	F.52	184692	P9MPS23G	F.17	186439	P9SSC20T95	F.14
173034	077CF73034	F.31	180543	077SP6SFE	F.52	184693	P9MPS34G	F.17	186461	P9SSC25A95	F.15
173037	077CF73037	F.31	180544	077SP9SFE	F.52	184694	P9MPS35G	F.17	186467	P9SSC23C95	F.15
173038	077CF73038	F.31	180545	077SP12SFE	F.52	184695	P9MCD	F.17	186551	P9SEM3RL	F.16
173040	077CF73040	F.31	180546	077SP16SFE	F.52	184696	P9MCB	F.17	186561	P9SET4RL1	F.16
173095	077C3095	F.31	180547	077SP20SFE	F.52	184697	P9MCC	F.17	186695	P9SCD	F.17
173208	080CPDT	F.10	180548	077SP25SFE	F.52	184700	P9MMN2F	F.19	186772	P9SZ	F.18
173220	080QDF	F.29	180549	077SP30SFE	F.52	184701	P9MMN2T	F.19	186773	P9SBD	F.18
173353	077C3353	F.31	180550	077SP36SFE	F.52	184702	P9MMN2A	F.19	186774	P9SBM	F.18
173455	077CR455	F.31	180551	077SP4VSFC	F.52	184703	P9MMN2B	F.19	186880	P9DPLNRG00	F.10
173901	077C9901	F.31	180552	077SP36SFC	F.52	184710	P9MMB2F	F.19	186881	P9DPLVRG00	F.10
173902	077C9902	F.31	180553	077SP4VSF	F.52	184711	P9MMB2T	F.19	186882	P9DPLNRS00	F.10
173903	077C9903	F.31	180554	077SP36SF	F.52	184712	P9MMB2A	F.19	186883	P9DPLVRS00	F.10
173904	077C9904	F.31	180601	077SLD11	F.44	184713	P9MMB2B	F.19	186890	P9DPLNRG01	F.10
173905	077C9905	F.31	180606	077SLX22	F.44	184720	P9MMN4F	F.19	186891	P9DPLVRG01	F.10
173910	077C9910	F.31	180607	077SLB11	F.44	184721	P9MMN4T	F.19	186892	P9DPLNRS01	F.10
173916	077C9916	F.31	180623	077SLZ22	F.44	184740	P9MMB4F	F.19	186893	P9DPLVRS01	F.10
173919	077C9919	F.31	180625	077SLZ22DC	F.44	184741	P9MMB4T	F.19	187000		
179000			180626	077SLZ22RC	F.44	184770	P9MWR	F.18	187000	P9B11VN	F.20
179510	080XTGR03	F.32	180630	077SCD1101	F.45	184771	P9MRG	F.18	187001	P9B01VN	F.20
179511	080XTGR03	F.32	180631	077SCD1105	F.45	184772	P9MZ	F.18	187002	P9B10VN	F.20
179514	080XTGR	F.32	180632	077SCD1109	F.45	185000			187003	P9B01VR	F.20
179515	080XTG8	F.32	180636	077SCH115C03	F.45	185070	P9XER3RN	F.11	187004	P9B10VA	F.20
179525	080XTGR01	F.32	180640	077SCH11DC03	F.45	185071	P9XER4RN	F.11	187008	P9B02VN	F.20
179526	080XTGR02	F.32	180843	077SCB1120	F.45	185077	P9XER4RAN	F.11	187009	P9B20VN	F.20
179527	080XTGR04	F.32	180852	077SCB11DC07	F.45	185078	P9XER4RAW	F.11	187012	P9B01FN	F.20
179528	080XTGR05	F.32	180853	077SCB11RC03	F.45	185079	P9XEC4RA95N	F.11	187013	P9B10FN	F.20
179529	080XTGR06	F.32	180906	077SC22DC01	F.45	185110	P9XSM0D0N	F.12	187014	P9B01FH	F.20
179530	080XTGR07	F.32	180910	077MTS2422	F.46	185120	P9XSMION	F.12	187015	P9B10FH	F.20
179531	080XTGR08	F.32	180911	077MT24S22	F.46	185150	P9XSM05N	F.12	187017	P9B01BN	F.23
179535	080XTGR01	F.32	180912	077MTS2422R	F.46	185190	P9XSMU0N	F.12	187018	P9B10BN	F.23
179536	080XTGR02	F.32	180913	077MT24S22R	F.46	185200	P9XSMZ0N	F.12	187020	P9PDNVO	F.21
179537	080XTGR04	F.32	180914	077M2S2S44	F.46	185240	P9XSMZ1N	F.12	187021	P9PRLVJ	F.21
179538	080XTGR05	F.32	180915	077M2T2TX44	F.46	185280	P9XSMZ5N	F.12	187022	P9PRDVN	F.21
179539	080XTGR06	F.32	180918	077M2S2TX44	F.46	185320	P9XSMZ3N	F.12	187023	P9PRNVJ	F.21
179540	080XTGR07	F.32	180919	077M2T2TX44	F.46	185330	P9XSMX0N	F.12	187024	P9PRNVN	F.21
179541	080XTGR08	F.32	180921	077M4T4TX88	F.46	185370	P9XSV00N	F.13	187025	P9PREVJ	F.21
180000			180923	077M4S4TX88	F.46	185371	P9XSVI0N	F.13	187026	P9PREVL	F.21
180001	077-11	F.51	180927	077M4T4TV88	F.46	185373	P9XSV05N	F.13	187027	P9PDTVO	F.21
180002	077-10	F.51	180929	077MTS123422	F.46	185379	P9XSVZ0N	F.13	187028	P9PRTVN	F.21
180003	077-01	F.51	180931	077MT1234S22	F.46	185391	P9XSVZ3N	F.13	187040	P9PDMVD	F.21
180007	077-10A	F.51	180971	077GELR	F.47	185392	P9XSVX0N	F.13	187041	P9PDMVJ	F.21
180008	077-01R	F.51	180980	077GG03	F.47	185400	P9XSC0A095	F.14	187055	P9PDNFO	F.21
180009	099SPDTDB	F.51	180981	077GGM	F.47	185401	P9XSC0E095	F.14	187056	P9PDHF	F.20
180010	077GBCN	F.42	180982	077GGT	F.47	185402	P9XSC0K095	F.14	187070	P9PDNB0	F.23
180019	077P11	F.42	181000			185409	P9XSC05A95	F.14	187110	P9ARBGR 029	F.28
180020	077GBCN	F.42	181000	077MTS2422B	F.46	185410	P9XSC095	F.14	187111	P9ARBGN 028	F.28
180029	077P10	F.42	181001	077MT24S22B	F.46	185432	P9XSCU0T95	F.14	187112	P9ARBGV 028	F.28
180039	077P01	F.42	181002	077MTS2422RB	F.46	185433	P9XSC20A95	F.14	187117	P9ARBGN 006	F.28
180040	077GBCS	F.42	181003	077MT24S22RB	F.46	185434	P9XSC20C95	F.14	187118	P9ARBGV 006	F.28
180049	077E11	F.43	181004	077M2S2S444B	F.46	185435	P9XSC20E95	F.14	187125	P9ARBGN 017	F.28
180050	077GBCS	F.42	181005	077M2T2TX44B	F.46	185439	P9XSC20T95	F.14	187127	P9ARBGN 018	F.28
180059	077E10	F.43	181008	077M4S4TX88B	F.46	185461	P9XSC25A95	F.15	187143	P9ARBGL 037	F.28
180069	077E01	F.43	181009	077M4T4TV88B	F.46	185462	P9XSC25C95	F.15	187144	P9ARBGR 036	F.28
180079	077RE11	F.43	181019	077MTS123422B	F.46	185463	P9XSC25H95	F.15	187145	P9ARBGN 030	F.28
180089	077RE10	F.43	181021	077MT1234S22B	F.46	185467	P9XSC23C95	F.15	187146	P9ARBGV 030	F.28
180090	077RER	F.43	181040	077PLM11D0	F.47	185571	P9XET4RL2	F.16	187147	P9ARBGR 201	F.28
180091	077RER60	F.43	181041	077PLM20D0	F.47	185695	P9XCD	F.17	187148	P9ARBGN 202	F.28
180099	077RE01	F.43	181043	077PLM10D0	F.47	185700	P9XMN2F	F.19	187149	P9ARBGV 202	F.28
180100	077PC11C	F.43	181060	077SD11D0	F.48	185701	P9XMN2T	F.19	187150	P9ARBGN 029	F.28
180104	077PC11G	F.43	181170	077SB11D0	F.48	185710	P9XMB2F	F.19	187151	P9ARBGB 028	F.28
180120	077P11T30	F.42	181174	077SB11D0RC	F.48	185711	P9XMB2T	F.19	187152	P9ARBGB 006	F.28
180121	077P11T180	F.42	181176	077SZ11D0RC	F.48	185712	P9XMB2A	F.19	187190	BA9S130LED	F.31
180136	077GBCF	F.42	181260	077DLE14	F.49	185713	P9XMB2B	F.19	187191	BA9S60LED	F.31
180137	077GBCF	F.42	181300	077LDNVO	F.49	185720	P9XMN4F	F.19	187210	P9ARBSR 029	F.28
180170	077SDN11	F.44	181301	077LRNVJ	F.49	185721	P9XMN4T	F.19	187211	P9ARBSN 028	F.28
180180	077SHN11	F.44	181302	077LRNVN	F.49	185740	P9XMB4F	F.19	187212	P9ARBSV 028	F.28
180230	077SBN11	F.44	181305	077LDMVD	F.49	185741	P9XMB4T	F.19	187217	P9ARBSN 006	F.28
180240	077SBN11SC	F.44	181550	077DPP	F.50	185771	P9XRG	F.18	187218	P9ARBSV 006	F.28
180250	077SBN11DC	F.44	181554	077DAE	F.50	185772	P9XZ	F.18	187245	P9ARBSN 030	F.28
180260	077SBN11RC	F.44	181570	077OPZ	F.50	185773	P9XBD	F.18	187246	P9ARBSV 030	F.28
180440	077SUN22	F.44	181588	077CPT	F.50	185774	P9XBM	F.18	187247	P9ARBSR 201	F.28
180480	077SN22	F.44	181600	077PLI	F.50	185788	080QDF027	F.29	187248	P9ARBSN 202	F.28
180510	077SN22RC	F.44	181601	077TPF	F.50	185789	080QDF030	F.29	187249	P9ARBSV 202	F.28
180521	077SP1	F.52	181602	077ECR	F.43	186000			187250	P9ARBSN 029	F.28
180522	077SP1M	F.52	181603	077CST	F.50	186031	P9SEM3RN	F.11	187251	P9ARBSB 028	F.28
180523	077SP2	F.52	181608	077PTB10	F.51	186061	P9SET4R	F.11	187252	P9ARBSB 006	F.28

By reference number

Intro

B

B

Ref. no	Cat. no	Page	Ref. no	Cat. no	Page	Ref. no	Cat. no	Page	Ref. no	Cat. no	Page
187300	P9ARDLS	F.29	187856	BA9S6012	F.31	200910	114FCT21	G.29	211728	RSS13/64TA33	A.154
187301	P9ARDLS029	F.29	187857	BA9S130	F.31	201000			211730	RSS13/64TA39	A.154
187302	P9ARDLS028	F.29	187860	BA9SN110	F.31	201942	IP	G.27	211731	RSS13/64TA47	A.154
187305	P9ARDLS006	F.29	187861	BA9SN220	F.31	201943	IB	G.27	211735	RSS13/64TA5.6	A.154
187309	P9ARDLS017	F.29	187868	BA9S220	F.31	201944	IR	G.27	211737	RSS13/64TA15	A.154
187310	P9ARDLS018	F.29	188000			202000			211739	RSS20/165TA470	A.154
187311	P9ARDLS026	F.29	188000	P9ARTBS	F.31	202273	390/3921PFZCS14	A.155	211742	RSS13/64TA10	A.154
187312	P9ARDLS027	F.29	188001	P9ARTBM	F.31	202274	390/3921PFZCS45	A.155	211743	RSS13/64TA100	A.154
187313	P9ARDLS031	F.29	188002	P9ARPPM	F.32	202275	390/3921PMRN	A.155	211744	RSS13/64TA180	A.154
187314	P9ARDLS032	F.29	188005	P9ARTWS	F.31	202276	390/3921PMZI	A.155	211745	RSS13/64TA330	A.154
187315	P9ARDLS001	F.29	188008	P9ARTWM	F.31	202277	390/3921PZ	A.155	211746	RSS13/64TA390	A.154
187316	P9ARDLS002	F.29	188010	P9ASTBS	F.31	202278	390/3922PFZCS90	A.155	211748	RSS20/165TA390	A.154
187318	P9ARDLS030	F.29	188011	P9ASTWS	F.31	202279	390/3922PMZI	A.155	211770	3906Y230D	A.154
187319	P9ARDLS201	F.29	188012	P9ARTTS	F.31	202280	390/3922PZ	A.155	212000		
187320	P9ARDLS202	F.29	188014	P9ASTTS	F.31	202281	390/3923PFZCS125	A.155	212165	SKB-B250/220-4	A.154
187350	P9ARDPL	F.29	188015	P9ACPBS	F.32	202282	390/3923PMRN	A.155	212558	SFS04M	C.34
187351	P9ARDPLO29	F.29	188017	P9ACPWS	F.32	202283	390/3923PMZI	A.155	212559	SFS05M	C.34
187352	P9ARDPLO28	F.29	188018	P9ACPTS	F.32	202284	390/3923PZ	A.155	212702	RSS13/64TA220	A.154
187355	P9ARDPLO06	F.29	188019	P9ARTTM	F.31	202287	390/3924PFRN	A.155	212705	3903Y48D	A.154
187359	P9ARDPLO17	F.29	188028	P9ARPWM	F.32	202288	390/3924PFZCS125	A.155	212706	3905Y220D	A.154
187360	P9ARDPLO18	F.29	188030	P9ACPBS039	F.32	202289	390/3924PFZCS200	A.155	212707	3906Y48D	A.154
187361	P9ARDPLO26	F.29	188043	P9ARSCMN	F.19	202290	390/3924PMRN	A.155	212709	390/3922PFRN	A.155
187362	P9ARDPLO27	F.29	188044	P9ARSCMB	F.19	202291	390/3924PMZI	A.155	212759	RS01NEN	G.4
187363	P9ARDPLO31	F.29	188201	P9ACPBS201	F.32	202292	390/3924PZ	A.155	212959	3908Y97D	A.154
187364	P9ARDPLO32	F.29	188202	P9ACPBS202	F.32	202295	390/3925PFZCS320	A.155	212962	3909PMZ	A.156
187365	P9ARDPLO01	F.29	188203	P9ACPBS203	F.32	202297	390/3925PMRN	A.155	213000		
187366	P9ARDPLO02	F.29	188204	P9ACPBS204	F.32	202298	390/3925PMZI	A.155	213014	390/3922PMRN	A.155
187368	P9ARDPLO30	F.29	188205	P9ACPBS205	F.32	202299	390/3925PZ	A.155	213034	RSS13/64TA1200	A.154
187369	P9ARDPLO21	F.29	188206	P9ACPBS206	F.32	202303	390/3926PFZCS270	A.155	213573	390/3925PFZCS150	A.155
187370	P9ARDPLO20	F.29	188207	P9ACPBS207	F.32	202304	390/3926PMZI	A.155	213574	390/3926PFZCS450	A.155
187491	P9ARHPR	F.30	188208	P9ACPBS208	F.32	202306	390/3927PFRN	A.156	213601	3904Y97D	A.154
187492	P9ARRR4	F.30	188215	P9ACPBS215	F.32	202307	390/3927PFZCS320	A.156	213612	3906Y220D	A.154
187495	P9ARSGMN	F.19	188222	P9ACPBS222	F.32	202308	390/3927PFZCS630	A.156	213663	RSS20/165TA100	A.154
187496	P9ARSGMB	F.19	188224	P9ACPBS224	F.32	202309	390/3927PMRN	A.156	213664	RSS20/165TA120	A.154
187510	P9ASBGR 029	F.28	188231	P9ACPBS231	F.32	202310	390/392PMZI	A.156	213691	3903Y97D	A.154
187511	P9ASBGN 028	F.28	188232	P9ACPBS232	F.32	202311	390/3927PZ	A.156	213814	3904Y48D	A.154
187512	P9ASBGV 028	F.28	188233	P9ACPBS233	F.32	202323	39012Y110D	A.154	213986	390/3923PFRN	A.155
187517	P9ASBGN 006	F.28	188234	P9ACPBS234	F.32	202324	39012Y125D	A.154	214000		
187518	P9ASBGV 006	F.28	188239	P9ACPBS239	F.32	202325	39012Y197D	A.154	214066	3908Y197D	A.154
187543	P9ASBGL 037	F.28	188243	P9ACPBS243	F.32	202326	39012Y220D	A.154	214081	RSS20/165TA82	A.154
187545	P9ASBGN 030	F.28	188258	P9ACPBS258	F.32	202327	39012Y24D	A.154	214120	390/3921/2FOM4/	A.155
187546	P9ASBGV 030	F.28	188801	P9ARAM32	F.32	202328	39012Y97D	A.154	214121	390/3922FOM5/2	A.155
187547	P9ASBGR 201	F.28	188804	P9ACA6	F.20	202437	3903Y110D	A.154	214122	390/3923/2FOM4/	A.155
187548	P9ASBGN 202	F.28	188805	P9ARSN1	F.30	202438	3903Y220D	A.154	214123	390/3923FOM5/2	A.155
187549	P9ASBGV 029	F.28	188909	P9ARBGB 202	F.28	202479	3904Y110D	A.154	214124	390/3924F4	A.155
187550	P9ASBGN 029	F.28	188978	P9ARBGB 202	F.28	202480	3904Y125D	A.154	214126	390/3924M4/2	A.155
187551	P9ASBGB 028	F.28	189000			202481	3904Y197D	A.154	214127	390/3924M5/2	A.155
187552	P9ASBGB 006	F.28	189000	P9EPEG1	F.24	202482	3904Y220D	A.154	214128	390/3925F4/2	A.155
187610	P9ASBSR 029	F.28	189001	P9EPE01	F.24	202483	3904Y24D	A.154	214129	390/3925F5/2	A.155
187611	P9ASBSN 028	F.28	189002	P9EPE02	F.24	202512	3905Y110D	A.154	214130	390/3925M4/2	A.155
187612	P9ASBSV 028	F.28	189003	P9EPE03	F.24	202513	3905Y97D	A.154	214131	390/3925M5/2	A.155
187617	P9ASBSN 006	F.28	189004	P9EPE04	F.24	202532	3906Y110D	A.154	214133	390/3926F4/2	A.155
187618	P9ASBSV 006	F.28	189005	P9EPE06	F.24	202533	3906Y97D	A.154	214134	390/3926F5/2	A.155
187643	P9ASBSL 037	F.28	189006	P9EPEG2	F.24	202547	3907Y110D	A.154	214135	390/3926M4/2	A.155
187645	P9ASBSN 030	F.28	189007	P9EPAG1YON	F.25	202548	3907Y220D	A.154	214136	390/3926M5/2	A.155
187646	P9ASBSV 030	F.28	189008	P9EPAG1Y01W	F.25	202555	3908PFZCS400	A.156	214137	390/3927F4/2	A.156
187647	P9ASBSR 201	F.28	189009	P9EPAG1Y06N	F.25	202562	3908PFZCS800	A.156	214138	390/3927F5/2	A.156
187648	P9ASBSN 202	F.28	189010	P9EPA01Y02	F.25	202563	3908PMZ	A.156	214139	390/3927M4/2	A.156
187649	P9ASBSV 202	F.28	189011	P9EPA01Y03	F.25	202564	3908PZ	A.156	214140	390/3927M5/2	A.156
187650	P9ASBSN 029	F.28	189016	P9EPA02Y01	F.25	202565	3908Y110D	A.154	214141	3908/9M4/2	A.156
187651	P9ASBSB 028	F.28	189018	P9EPA03Y01	F.25	202566	3908Y220D	A.154	214142	3908/9M5/2	A.156
187652	P9ASBSB 006	F.28	189022	P9EPA03Y05	F.25	202572	3909Y110D	A.154	214144	3908F4/2	A.156
187701	080QDF029	F.29	189029	P9AEMT	F.24	202654	390/3926PZ	A.155	214145	3908F5/2	A.156
187702	080QDF028	F.29	189030	P9AELN	F.24	204000			214146	3909Y97D	A.154
187705	080QDF006	F.29	189031	P9AELN202	F.24	204165	WKAT 35-1.2A/2V	G.3	214399	RSS13/64TA270	A.154
187709	080QDF017	F.29	189032	P9AELN201	F.24	204166	WKAT 70-1.2A/2V	G.3	214400	RSS13/64TA820	A.154
187710	080QDF018	F.29	189033	P9AELN214	F.24	204169	WKAT 35-10A/2V	G.3	214442	3903Y197D	A.154
187711	080QDF026	F.29	189034	P9AELN215	F.24	204170	WKAT 70-10A/2V	G.3	214501	SKB-B500/445-4	A.154
187713	080QDF031	F.29	189035	P9AELN205	F.24	204177	RSS13/64TA8.2	A.154	214580	RSS13/64TA680	A.154
187714	080QDF032	F.29	189036	P9AELN206	F.24	204178	390/3924F5/2	A.155	214869	RSS13/64TA6.8	A.154
187715	080QDF001	F.29	189037	P9AELN204	F.24	204179	3909F4/2	A.156	215000		
187716	080QDF002	F.29	189038	P9AELN203	F.24	204180	3909F5/2	A.156	215004	RSS20/165TA150	A.154
187719	080QDF201	F.29	189041	P9AELN006	F.24	204181	3909Y197D	A.154	215252	115PC015A	G.38
187720	080QDF202	F.29	189042	P9AELN028	F.24	204800	C09479	A.65	215253	115PC002A	G.38
187792	P9ASHP3	F.30	189043	P9AELN029	F.24	209000			215278	3903Y20D	A.154
187793	P9ASHP5	F.30	189044	P9AELN035	F.24	209140	IUGA-B211 S	G.25	215320	1158065SPA	G.38
187794	P9ASHAC	F.30	189045	P9AELN038	F.24	209344	LG0004P1B0	A.59	215321	1158067SPA	G.38
187795	P9ASEBG	F.30	189046	P9AELN039	F.24	209347	LG0004S1B0	A.59	215329	115PC119A	G.38
187796	P9ADCST	F.10	189047	P9AELN042	F.24	209780	MG0004PATO	A.51	215432	P9EPC01X00	F.25
187840	P9ACRCL	F.30	189136	P9EPL02X01	F.26	209781	MG0006PATO	A.51	215433	P9EPC01X01	F.25
187841	P9ACFS3	F.30	189137	P9EPL02X02	F.26	209977	MSK-B250/220-1.5	A.154	216000		
187842	P9ACFS5	F.30	189138	P9EPL03X01	F.26	211000			216100	3903Y125D	A.154
187843	P9ACDPP	F.30	189139	P9EPL03X02	F.26	211107	3903Y230D	A.154	216604	SFE04K1	C.34
187844	P9ACVLR	F.30	189140	P9EPL03X03	F.26	211706	39012Y230D	A.154	220000		
187845	P9ACWAF	F.30	189141	P9EPL04X01	F.26	211708	3904Y230D	A.154	220019	PRC2P20ABL	B.4
187846	P9ACFSM	F.20	189152	P9AELN222	F.24	211709	3905Y230D	A.154	220020	PRC2P20ADL	B.4
187847	P9ACAFV	F.30	189154	P9AELN224	F.24	211711	3906Y125D	A.154	220021	PRC2P20AGL	B.4
187850	BA9S606	F.31	189200	P9EPEM	F.24	211712	3907Y230D	A.154	220022	PRC2P20CBL	B.4
187851	BA9S615	F.31	189859	P9ASBGB 202	F.28	211713	3907Y125D	A.154	220023	PRC2P20CDL	B.4
187852	BA9S122	F.31	189928	P9ASBSB 202	F.28	211714	RSS13/64TA300	A.154	220024	PRC2P20AJL	B.4
187853	BA9S242	F.31	200000			211716	SKB-B80/70-4	A.154	220025	PRC2P20CGL	B.4
187854	BA9S30	F.31	200004	LG0006P1B0	A.59	211720	SKB-B30/08	A.154	220026	PRC2P20ANL	B.4
187855	BA9S48	F.31	200909	114FCT							

Ref. no	Cat. no	Page	Ref. no	Cat. no	Page	Ref. no	Cat. no	Page	Ref. no	Cat. no	Page
220041	PRC2P20DCBL	B.4	221920	PRCMS16	B.5	244088	3903Y40D	A.154	267036	EC18A311B230	A.6
220042	PRC2P20DCDL	B.4	221921	PRCTR	B.5	244106	39012Y40D	A.154	267037	EC18A311B240	A.6
220043	PRC2P20DCGL	B.4	221934	PRCG-ES15/4N	B.3	244107	39012Y20D	A.154	267038	EC18A311B400	A.6
220044	PRC2P20DCJL	B.4	222000			244172	390/3921PFZCS25	A.155	267039	EC18A311B440	A.6
220216	PRC2B	B.4	222004	PRC1S13BDL	B.5	244173	390/3921PFRN	A.155	267040	EC18A311B480	A.6
220217	PRC2B	B.4	222007	PRC1S13CBL	B.5	244191	RSS13/64TA470	A.154	267041	EC18A311B500	A.6
220218	PRCP211	B.4	222008	PRC1S13CDL	B.5	244192	RSS13/64TA27	A.154	267042	EC18A311B600	A.6
220219	PRCR159	B.4	222013	PRC1S13BNL	B.5	244734	39012Y48D	A.154	267043	EC25A311B012	A.6
220310	PRC3P30ABL	B.4	222100	PRCM21P	B.6	244735	3903Y24D	A.154	267044	EC25A311B024	A.6
220311	PRC3P30ADL	B.4	222101	PRCM21N	B.6	244736	3905Y48D	A.154	267045	EC25A311B042	A.6
220312	PRC3P30AGL	B.4	222102	PRCM31R	B.6	244737	3907Y48D	A.154	267046	EC25A311B048	A.6
220313	PRC3P30CBL	B.4	222103	PRCM32R	B.6	244738	3907Y97D	A.154	267047	EC25A311B110	A.6
220314	PRC3P30CDL	B.4	222104	PRCM31G	B.6	244739	3909Y220D	A.154	267048	EC25A311B120	A.6
220315	PRC3P30AUL	B.4	222105	PRCM32G	B.6	244744	390/3922PFZCS45	A.155	267049	EC25A311B208	A.6
220316	PRC3P30CGL	B.4	222106	PRCM33G	B.6	244745	390/3923PFZCS75	A.155	267050	EC25A311B230	A.6
220317	PRC3P30ANL	B.4	222107	PRCM41G	B.6	244746	390/3925PFRN	A.155	267051	EC25A311B240	A.6
220318	PRC3P30CJL	B.4	222109	PRCM33R	B.6	244983	3909PFZCS120	A.156	267052	EC25A311B400	A.6
220355	PRC3P30DCBL	B.4	222110	PRCM41R	B.6	244987	RSS20/165TA560	A.154	267053	EC25A311B440	A.6
220356	PRC3P30DCDL	B.4	222111	PRCM42R	B.6	245000			267054	EC25A311B480	A.6
220357	PRC3P30DCGL	B.4	222112	PRCM43R	B.6	245217	SFS04K1	C.34	267055	EC25A311B500	A.6
220358	PRC3P30DCJL	B.4	222113	PRCM51	B.6	247000			267056	EC25A311B600	A.6
220647	PRC211	G.3	222114	PRCM52	B.6	247302	RE1XP	A.75	267057	EC32A300B012	A.6
220648	PRCG11	B.4	222115	PRCM53	B.6	247303	RE2XP	A.75	267058	EC32A300B024	A.6
220710	PRCAM20ABL	B.3	222116	PRCM91R	B.6	247532		E.13	267059	EC32A300B042	A.6
220711	PRCAM20ADL	B.3	222120	PRCM93G	B.6	247533		E.13	267060	EC32A300B048	A.6
220712	PRCAM20AGL	B.3	222121	PRCM71	B.6	247534		E.13	267061	EC32A300B110	A.6
220713	PRCAM20CBL	B.3	222122	PRCM73	B.6	247536		E.13	267062	EC32A300B120	A.6
220714	PRCAM20CDL	B.3	222124	PRCM42G	B.6	247537		E.13	267063	EC32A300B208	A.6
220715	PRCAM20AJL	B.3	222125	PRCM43G	B.6	247538		E.13	267064	EC32A300B230	A.6
220716	PRCAM20CGL	B.3	222126	PRCM91G	B.6	247788	115PC2018A	G.38	267065	EC32A300B240	A.6
220717	PRCAM20ANL	B.3	222278	NLT73BD	F.65	247795	RETC	A.75	267066	EC32A300B400	A.6
220718	PRCAM20CJL	B.3	222279	NLT77BD	F.65	247990	EA07A310S024	A.43	267067	EC32A300B440	A.6
220754	PRCAM20DCBL	B.3	222280	NLT77AJ	F.65	247991	EA07A301S024	A.43	267068	EC32A300B480	A.6
220755	PRCAM20DCDL	B.3	222281	NLT77AN	F.65	247992	EA07A310S048	A.43	267069	EC32A300B500	A.6
220756	PRCAM20DCGL	B.3	222282	NLT9TC	F.65	247993	EA07A301S048	A.43	267070	EC32A300B600	A.6
220757	PRCAM20DCJL	B.3	222284	NLT5BT	F.65	247994	EA07A310S110	A.43	267071	EC40A300B012	A.6
220912	PRCG-ES15/2N	B.3	222285	NLT5ET	F.65	247995	EA07A301S110	A.43	267072	EC40A300B024	A.6
220914	PRCG1052	B.3	222286	NLT5BD	F.65	247996	EA07A310S230	A.43	267073	EC40A300B042	A.6
220915	PRCMS35	B.3	222287	NLT75AJ	F.65	247997	EA07A301S230	A.43	267074	EC40A300B048	A.6
220916	PRCTR1	B.3	222288	NLT75AN	F.65	247998	EA07D310S024	A.43	267075	EC40A300B110	A.6
221000			222307	NLT90BT	F.65	247999	EA07D301S024	A.43	267076	EC40A300B120	A.6
221051	PRCAM30ABL	B.3	222330	BA15D24LR	F.65	248000			267077	EC40A300B208	A.6
221052	PRCAM30ADL	B.3	222331	BA15D24LA	F.65	248001	EA07D310S110	A.43	267078	EC40A300B230	A.6
221053	PRCAM30AGL	B.3	222332	BA15D24LG	F.65	248002	EA07D301S110	A.43	267079	EC40A300B240	A.6
221054	PRCAM30CBL	B.3	222333	BA15D24LV	F.65	248003	EA07A310I230	A.43	267080	EC40A300B400	A.6
221055	PRCAM30CDL	B.3	222334	BA15D24LL	F.65	248004	EA07A301I230	A.43	267081	EC40A300B440	A.6
221056	PRCAM30AJL	B.3	222335	BA15D24LB	F.65	248004	EA07A310I024	A.43	267082	EC40A300B480	A.6
221057	PRCAM30CGL	B.3	222336	BA15D115LR	F.65	248005	EA07A301I024	A.43	267083	EC40A300B500	A.6
221058	PRCAM30ANL	B.3	222337	BA15D115LA	F.65	248006	EA07D310I048	A.43	267084	EC40A300B600	A.6
221059	PRCAM30CJL	B.3	222338	BA15D115LG	F.65	248007	EA07D301I048	A.43	267085	EC09D311B012W	A.6
221074	PRCAM30DCBL	B.3	222339	BA15D115LV	F.65	248008	EA07D310I110	A.43	267086	EC09D311B024W	A.6
221075	PRCAM30DCDL	B.3	222340	BA15D115LL	F.65	248009	EA07D301I110	A.43	267087	EC09D311B036W	A.6
221076	PRCAM30DCGL	B.3	222341	BA15D115LB	F.65	248083	BCLL11-K	A.64	267088	EC09D311B048W	A.6
221077	PRCAM30DCJL	B.3	222342	BA15D230LR	F.65	254000			267089	EC09D311B060W	A.6
221442	PRCG-ES15/3N	B.3	222343	BA15D230LA	F.65	254537	SFV88	C.13	267090	EC09D311B072W	A.6
221809	PRCAM40ABL	B.3	222344	BA15D230LG	F.65	264000			267091	EC09D311B110W	A.6
221810	PRCAM40ADL	B.3	222345	BA15D230LV	F.65	264826	SFALPEN	C.33	267092	EC09D311B125W	A.6
221811	PRCAM40AGL	B.3	222346	BA15D230LL	F.65	267001	EC09A311B012	A.6	267093	EC09D311B230W	A.6
221812	PRCAM40CBL	B.3	222347	BA15D230LB	F.65	267002	EC09A311B024	A.6	267094	EC09D311B250W	A.6
221813	PRCAM40CDL	B.3	222348	BA15D125	F.65	267003	EC09A311B042	A.6	267095	EC09D311B440W	A.6
221814	PRCAM40AJL	B.3	222349	BA15D245	F.65	267004	EC09A311B048	A.6	267096	EC09D311B024L	A.6
221815	PRCAM40CGL	B.3	222350	BA15D305	F.65	267005	EC09A311B048	A.6	267097	EC09D311B048L	A.6
221816	PRCAM40ANL	B.3	222351	BA15D1155	F.65	267006	EC09A311B110	A.6	267098	EC09D311B110L	A.6
221817	PRCAM40CJL	B.3	222352	BA15D2305	F.65	267007	EC09A311B120	A.6	267099	EC09D311B230L	A.6
221851	PRCAM40DCBL	B.3	223000			267008	EC09A311B208	A.6	267100	EC12D311B012W	A.6
221852	PRCAM40DCDL	B.3	223000	IPSF1	F.70	267009	EC09A311B230	A.6	267101	EC12D311B024W	A.6
221853	PRCAM40DCGL	B.3	241000			267010	EC09A311B240	A.6	267102	EC12D311B036W	A.6
221854	PRCAM40DCJL	B.3	241311	115PC018A	G.38	267011	EC09A311B400	A.6	267103	EC12D311B048W	A.6
221860	PRC1T20CBL	B.5	241747	PVP85G	A.66	267012	EC09A311B440	A.6	267104	EC12D311B060W	A.6
221861	PRC1T20CDL	B.5	241748	PVP10G	A.66	267013	EC09A311B480	A.6	267105	EC12D311B072W	A.6
221862	PRC1T20CJL	B.5	241749	PCP12G	A.66	267014	EC09A311B500	A.6	267106	EC12D311B110W	A.6
221868	PRC1T20ADL	B.5	241750	WLS01	A.60	267015	EC09A311B600	A.6	267107	EC12D311B125W	A.6
221869	PRC1T20AJL	B.5	241751	WKI0910	A.60	267016	EC12A311B012	A.6	267108	EC12D311B230W	A.6
221870	PRC1T20ANL	B.5	241752	WKI0608	A.60	267017	EC12A311B024	A.6	267109	EC12D311B250W	A.6
221875	PRC1T10CBL	B.5	242000			267018	EC12A311B048	A.6	267110	EC12D311B440W	A.6
221876	PRC1T10CDL	B.5	242260	3905Y125D	A.154	267019	EC12A311B110	A.6	267111	EC12D311B024L	A.6
221877	PRC1T10CJL	B.5	243000			267020	EC12A311B120	A.6	267112	EC12D311B048L	A.6
221883	PRC1T10ADL	B.5	243281	RSS13/64TA120	A.154	267021	EC12A311B120	A.6	267113	EC12D311B110L	A.6
221884	PRC1T10AJL	B.5	244000			267022	EC12A311B208	A.6	267114	EC12D311B230L	A.6
221885	PRC1T10ANL	B.5	244056	3907Y40D	A.154	267023	EC12A311B230	A.6	267115	EC18D311B012W	A.6
221890	PRCT1CB	B.5	244057	3907Y24D	A.154	267024	EC12A311B240	A.6	267116	EC18D311B024W	A.6
221891	PRCT1CD	B.5	244058	3907Y20D	A.154	267025	EC12A311B400	A.6	267117	EC18D311B036W	A.6
221892	PRCT1CJ	B.5	244059	3907Y197D	A.154	267026	EC12A311B440	A.6	267118	EC18D311B048W	A.6
221896	PRCT1AD	B.5	244063	3906Y40D	A.154	267027	EC12A311B480	A.6	267119	EC18D311B060W	A.6
221897	PRCT1AJ	B.5	244064	3906Y24D	A.154	267028	EC12A311B500	A.6	267120	EC18D311B072W	A.6
221898	PRCT1AN	B.5	244065	3906Y20D	A.154	267029	EC12A311B600	A.6	267121	EC18D311B110W	A.6
221905	PRCT2CB	B.5	244066	3906Y197D	A.154	267030	EC18A311B012	A.6	267122	EC18D311B125W	A.6
221906	PRCT2CD	B.5	244071	3905Y40D	A.154	267031	EC18A311B024	A.6	267123	EC18D311B230W	A.6
221907	PRCT2CJ	B.5	244072	3905Y24D	A.154	267032	EC18A311B042	A.6	267124	EC18D311B250W	A.6
221913	PRCT2AD	B.5	244073	3905Y20D	A.154	267033	EC18A311B048	A.6	267125	EC18D311B440W	A.6
221914	PRCT2AJ	B.5	244074	3905Y197D	A.154	267034	EC18A311B110	A.6	267126	EC18D311B024L	A.6
221915	PRCT2AN	B.5	244083	3904Y40D	A.154	267035	EC18A311B120	A.6	267127	EC18D311B048L	A.6
221918	PRCGZT80	B.5	244084	3904Y20D	A.154				267128	EC18D311B110L	A.6

By reference number

Intro

Ref. no	Cat. no	Page	Ref. no	Cat. no	Page	Ref. no	Cat. no	Page	Ref. no	Cat. no	Page
267129	EC18D311B230L	A.6	267223	EC32A400B208	A.7	267317	EC18AB00B500	A.8	268109	ECRT2B10W	A.14
267130	EC25D311B012W	A.6	267224	EC32A400B230	A.7	267318	EC18AB00B600	A.8	268140	ECACA440B012	A.9
267131	EC25D311B024W	A.6	267225	EC32A400B240	A.7	267319	EC25AB00B012	A.8	268141	ECACA440B024	A.9
267132	EC25D311B036W	A.6	267226	EC32A400B400	A.7	267320	EC25AB00B024	A.8	268142	ECACA440B042	A.9
267133	EC25D311B048W	A.6	267227	EC32A400B440	A.7	267321	EC25AB00B042	A.8	268143	ECACA440B048	A.9
267134	EC25D311B060W	A.6	267228	EC32A400B480	A.7	267322	EC25AB00B048	A.8	268144	ECACA440B110	A.9
267135	EC25D311B072W	A.6	267229	EC32A400B500	A.7	267323	EC25AB00B110	A.8	268145	ECACA440B120	A.9
267136	EC25D311B110W	A.6	267230	EC32A400B600	A.7	267324	EC25AB00B120	A.8	268146	ECACA440B208	A.9
267137	EC25D311B125W	A.6	267231	EC12D400B012W	A.7	267325	EC25AB00B208	A.8	268147	ECACA440B230	A.9
267138	EC25D311B230W	A.6	267232	EC12D400B024W	A.7	267326	EC25AB00B230	A.8	268148	ECACA440B240	A.9
267139	EC25D311B250W	A.6	267233	EC12D400B036W	A.7	267327	EC25AB00B240	A.8	268149	ECACA440B400	A.9
267140	EC25D311B440W	A.6	267234	EC12D400B048W	A.7	267328	EC25AB00B400	A.8	268150	ECACA440B440	A.9
267141	EC25D311B024L	A.6	267235	EC12D400B060W	A.7	267329	EC25AB00B440	A.8	268151	ECACA440B480	A.9
267142	EC25D311B048L	A.6	267236	EC12D400B072W	A.7	267330	EC25AB00B480	A.8	268152	ECACA440B500	A.9
267143	EC25D311B110L	A.6	267237	EC12D400B110W	A.7	267331	EC25AB00B500	A.8	268153	ECACA440B600	A.9
267144	EC25D311B230L	A.6	267238	EC12D400B125W	A.7	267332	EC25AB00B600	A.8	268154	ECACA431B012	A.9
267145	EC32D300B012W	A.6	267239	EC12D400B230W	A.7	267333	EC32AB00B012	A.8	268155	ECACA431B024	A.9
267146	EC32D300B024W	A.6	267240	EC12D400B250W	A.7	267334	EC32AB00B024	A.8	268156	ECACA431B042	A.9
267147	EC32D300B036W	A.6	267241	EC12D400B440W	A.7	267335	EC32AB00B042	A.8	268157	ECACA431B048	A.9
267148	EC32D300B048W	A.6	267242	EC12D400B024L	A.7	267336	EC32AB00B048	A.8	268158	ECACA431B110	A.9
267149	EC32D300B060W	A.6	267243	EC12D400B048L	A.7	267337	EC32AB00B110	A.8	268159	ECACA431B120	A.9
267150	EC32D300B072W	A.6	267244	EC12D400B110L	A.7	267338	EC32AB00B120	A.8	268160	ECACA431B208	A.9
267151	EC32D300B110W	A.6	267245	EC12D400B230L	A.7	267339	EC32AB00B208	A.8	268161	ECACA431B230	A.9
267152	EC32D300B125W	A.6	267246	EC18D400B012W	A.7	267340	EC32AB00B230	A.8	268162	ECACA431B240	A.9
267153	EC32D300B230W	A.6	267247	EC18D400B024W	A.7	267341	EC32AB00B240	A.8	268163	ECACA431B400	A.9
267154	EC32D300B250W	A.6	267248	EC18D400B036W	A.7	267342	EC32AB00B400	A.8	268164	ECACA431B440	A.9
267155	EC32D300B440W	A.6	267249	EC18D400B048W	A.7	267343	EC32AB00B440	A.8	268165	ECACA431B480	A.9
267156	EC32D300B024L	A.6	267250	EC18D400B060W	A.7	267344	EC32AB00B480	A.8	268166	ECACA431B500	A.9
267157	EC32D300B048L	A.6	267251	EC18D400B072W	A.7	267345	EC32AB00B500	A.8	268167	ECACA431B600	A.9
267158	EC32D300B110L	A.6	267252	EC18D400B110W	A.7	267346	EC32AB00B600	A.8	268168	ECACA422B012	A.9
267159	EC32D300B230L	A.6	267253	EC18D400B125W	A.7	267347	EC12D800B012W	A.8	268169	ECACA422B024	A.9
267160	EC40D300B012W	A.6	267254	EC18D400B230W	A.7	267348	EC12D800B024W	A.8	268170	ECACA422B042	A.9
267161	EC40D300B024W	A.6	267255	EC18D400B250W	A.7	267349	EC12D800B036W	A.8	268171	ECACA422B048	A.9
267162	EC40D300B036W	A.6	267256	EC18D400B440W	A.7	267350	EC12D800B048W	A.8	268172	ECACA422B110	A.9
267163	EC40D300B048W	A.6	267257	EC18D400B024L	A.7	267351	EC12D800B060W	A.8	268173	ECACA422B120	A.9
267164	EC40D300B060W	A.6	267258	EC18D400B048L	A.7	267352	EC12D800B072W	A.8	268174	ECACA422B208	A.9
267165	EC40D300B072W	A.6	267259	EC18D400B110L	A.7	267353	EC12D800B110W	A.8	268175	ECACA422B230	A.9
267166	EC40D300B110W	A.6	267260	EC18D400B230L	A.7	267354	EC12D800B125W	A.8	268176	ECACA422B240	A.9
267167	EC40D300B125W	A.6	267261	EC25D400B012W	A.7	267355	EC12D800B230W	A.8	268177	ECACA422B400	A.9
267168	EC40D300B230W	A.6	267262	EC25D400B024W	A.7	267356	EC12D800B250W	A.8	268178	ECACA422B440	A.9
267169	EC40D300B250W	A.6	267263	EC25D400B036W	A.7	267357	EC12D800B440W	A.8	268179	ECACA422B480	A.9
267170	EC40D300B440W	A.6	267264	EC25D400B048W	A.7	267358	EC12D800B024L	A.8	268180	ECACA422B500	A.9
267171	EC40D300B024L	A.6	267265	EC25D400B060W	A.7	267359	EC12D800B048L	A.8	268181	ECACA422B600	A.9
267172	EC40D300B048L	A.6	267266	EC25D400B072W	A.7	267360	EC12D800B110L	A.8	268182	ECACA413B012	A.9
267173	EC40D300B110L	A.6	267267	EC25D400B110W	A.7	267361	EC12D800B230L	A.8	268183	ECACA413B024	A.9
267174	EC40D300B230L	A.6	267268	EC25D400B125W	A.7	267362	EC18D800B012W	A.8	268184	ECACA413B042	A.9
267175	EC12A400B012	A.7	267269	EC25D400B230W	A.7	267363	EC18D800B024W	A.8	268185	ECACA413B048	A.9
267176	EC12A400B024	A.7	267270	EC25D400B250W	A.7	267364	EC18D800B036W	A.8	268186	ECACA413B110	A.9
267177	EC12A400B042	A.7	267271	EC25D400B440W	A.7	267365	EC18D800B048W	A.8	268187	ECACA413B120	A.9
267178	EC12A400B048	A.7	267272	EC25D400B024L	A.7	267366	EC18D800B060W	A.8	268188	ECACA413B208	A.9
267179	EC12A400B110	A.7	267273	EC25D400B048L	A.7	267367	EC18D800B072W	A.8	268189	ECACA413B230	A.9
267180	EC12A400B120	A.7	267274	EC25D400B110L	A.7	267368	EC18D800B110W	A.8	268190	ECACA413B240	A.9
267181	EC12A400B208	A.7	267275	EC25D400B230L	A.7	267369	EC18D800B125W	A.8	268191	ECACA413B400	A.9
267182	EC12A400B230	A.7	267276	EC32D400B012W	A.7	267370	EC18D800B230W	A.8	268192	ECACA413B440	A.9
267183	EC12A400B240	A.7	267277	EC32D400B024W	A.7	267371	EC18D800B250W	A.8	268193	ECACA413B480	A.9
267184	EC12A400B400	A.7	267278	EC32D400B036W	A.7	267372	EC18D800B440W	A.8	268194	ECACA413B500	A.9
267185	EC12A400B440	A.7	267279	EC32D400B048W	A.7	267373	EC18D800B024L	A.8	268195	ECACA413B600	A.9
267186	EC12A400B480	A.7	267280	EC32D400B060W	A.7	267374	EC18D800B048L	A.8	268196	ECACA404B012	A.9
267187	EC12A400B500	A.7	267281	EC32D400B072W	A.7	267375	EC18D800B110L	A.8	268197	ECACA404B024	A.9
267188	EC12A400B600	A.7	267282	EC32D400B110W	A.7	267376	EC18D800B230L	A.8	268198	ECACA404B042	A.9
267189	EC18A400B012	A.7	267283	EC32D400B125W	A.7	267377	EC25D800B012W	A.8	268199	ECACA404B048	A.9
267190	EC18A400B024	A.7	267284	EC32D400B230W	A.7	267378	EC25D800B024W	A.8	268200	ECACA404B110	A.9
267191	EC18A400B042	A.7	267285	EC32D400B250W	A.7	267379	EC25D800B036W	A.8	268201	ECACA404B120	A.9
267192	EC18A400B048	A.7	267286	EC32D400B440W	A.7	267380	EC25D800B048W	A.8	268202	ECACA404B208	A.9
267193	EC18A400B110	A.7	267287	EC32D400B024L	A.7	267381	EC25D800B060W	A.8	268203	ECACA404B230	A.9
267194	EC18A400B120	A.7	267288	EC32D400B048L	A.7	267382	EC25D800B072W	A.8	268204	ECACA404B240	A.9
267195	EC18A400B208	A.7	267289	EC32D400B110L	A.7	267383	EC25D800B110W	A.8	268205	ECACA404B400	A.9
267196	EC18A400B230	A.7	267290	EC32D400B230L	A.7	267384	EC25D800B125W	A.8	268206	ECACA404B440	A.9
267197	EC18A400B240	A.7	267291	EC12AB00B012	A.8	267385	EC25D800B230W	A.8	268207	ECACA404B480	A.9
267198	EC18A400B400	A.7	267292	EC12AB00B024	A.8	267386	EC25D800B250W	A.8	268208	ECACA404B500	A.9
267199	EC18A400B440	A.7	267293	EC12AB00B042	A.8	267387	EC25D800B440W	A.8	268209	ECACA404B600	A.9
267200	EC18A400B480	A.7	267294	EC12AB00B048	A.8	267392	EC32D800B012W	A.8	268210	ECACD440B012W	A.9
267201	EC18A400B500	A.7	267295	EC12AB00B110	A.8	267393	EC32D800B024W	A.8	268211	ECACD440B024W	A.9
267202	EC18A400B600	A.7	267296	EC12AB00B120	A.8	267394	EC32D800B036W	A.8	268212	ECACD440B036W	A.9
267203	EC25A400B012	A.7	267297	EC12AB00B208	A.8	267395	EC32D800B048W	A.8	268213	ECACD440B048W	A.9
267204	EC25A400B024	A.7	267298	EC12AB00B230	A.8	267396	EC32D800B060W	A.8	268214	ECACD440B060W	A.9
267205	EC25A400B042	A.7	267299	EC12AB00B240	A.8	267397	EC32D800B072W	A.8	268215	ECACD440B072W	A.9
267206	EC25A400B048	A.7	267300	EC12AB00B400	A.8	267398	EC32D800B110W	A.8	268216	ECACD440B110W	A.9
267207	EC25A400B110	A.7	267301	EC12AB00B440	A.8	267399	EC32D800B125W	A.8	268217	ECACD440B125W	A.9
267208	EC25A400B120	A.7	267302	EC12AB00B480	A.8	267400	EC32D800B230W	A.8	268218	ECACD440B230W	A.9
267209	EC25A400B208	A.7	267303	EC12AB00B500	A.8	267401	EC32D800B250W	A.8	268219	ECACD440B250W	A.9
267210	EC25A400B230	A.7	267304	EC12AB00B600	A.8	267402	EC32D800B440W	A.8	268220	ECACD440B440W	A.9
267211	EC25A400B240	A.7	267305	EC18AB00B012	A.8	267403	ECBSRSD1	A.13	268221	ECACD440B024L	A.9
267212	EC25A400B400	A.7	267306	EC18AB00B024	A.8	267404	ECBSRSD2	A.13			

Ref. no	Cat. no	Page	Ref. no	Cat. no	Page	Ref. no	Cat. no	Page	Ref. no	Cat. no	Page
268233	ECACD431B230W	A.9	268724	ECCS2A240S	A.10	269008	ECRT1B10S	A.14	402925	6KGP43010X4XXXA1	H.38
268234	ECACD431B250W	A.9	268725	ECCS2A400S	A.10	269009	ECRT1B10T	A.14	402926	6KGP43015X4XXXA1	H.38
268235	ECACD431B440W	A.9	268726	ECCS2A440S	A.10	269075	EC09A311B575	A.6	402927	6KGP43020X4XXXA1	H.38
268236	ECACD431B024L	A.9	268727	ECCS2A480S	A.10	269076	EC12A311B575	A.6	402928	6KGP43025X4XXXA1	H.38
268237	ECACD431B048L	A.9	268728	ECCS2A500S	A.10	269077	EC18A311B575	A.6	402929	6KGP43030X4XXXA1	H.38
268238	ECACD431B110L	A.9	268729	ECCS2A600S	A.10	269078	EC25A311B575	A.6	402930	6KGP43040X4XXXA1	H.38
268239	ECACD431B230L	A.9	268730	ECCS2D0125S	A.10	269079	EC32A300B575	A.6	402931	6KGP43050X4XXXA1	H.38
268240	ECACD422B012W	A.9	268731	ECCS2D0245S	A.10	269080	EC40A300B575	A.6	402932	6KGP43060X4XXXA1	H.38
268241	ECACD422B024W	A.9	268732	ECCS2D0365S	A.10	269081	EC12A400B575	A.7	402933	6KGP43075X4XXXA1	H.38
268242	ECACD422B036W	A.9	268733	ECCS2D0485S	A.10	269082	EC18A400B575	A.7	402934	6KGP43100X4XXXA1	H.38
268243	ECACD422B048W	A.9	268734	ECCS2D0605S	A.10	269083	EC25A400B575	A.7			
268244	ECACD422B060W	A.9	268735	ECCS2D0725S	A.10	269084	EC32A400B575	A.7	403116	6KGP43F50X9XBXA1	H.33
268245	ECACD422B072W	A.9	268736	ECCS2D1105S	A.10	269115	EC12AB00B575	A.8	403117	6KGP43001X9XBXA1	H.33
268246	ECACD422B110W	A.9	268737	ECCS2D1255S	A.10	269116	EC18AB00B575	A.8	403118	6KGP43002X9XBXA1	H.33
268247	ECACD422B125W	A.9	268738	ECCS2D2305S	A.10	269117	EC25AB00B575	A.8	403119	6KGP43003X9XBXA1	H.33
268248	ECACD422B230W	A.9	268739	ECCS2D2505S	A.10	269118	EC32AB00B575	A.8	403120	6KGP43005X9XBXA1	H.33
268249	ECACD422B250W	A.9	268740	ECCS2D440S	A.10	269325	ECML1DS036	A.12	403121	6KGP43007X9XBXA1	H.33
268250	ECACD422B440W	A.9	268741	ECCS2D0245L	A.10	269326	ECML1DS048	A.12	403122	6KGP43010X9XBXA1	H.33
268251	ECACD422B024L	A.9	268742	ECCS2D0485L	A.10	269327	ECML1DS072	A.12	403123	6KGP43015X9XBXA1	H.33
268252	ECACD422B048L	A.9	268743	ECCS2D1105L	A.10	269328	ECML1DS177	A.12	403124	6KGP43020X9XBXA1	H.33
268253	ECACD422B110L	A.9	268744	ECCS2D2305L	A.10	269329	ECML1DS250	A.12	403125	6KGP43025X9XBXA1	H.33
268254	ECACD422B230L	A.9	268872	ECFA211S	A.11	269330	ECML1DS440	A.12	403126	6KGP43030X9XBXA1	H.33
268270	ECACD404B012W	A.9	268873	ECFA220S	A.11	269331	ECML2DS036	A.12	403127	6KGP43040X9XBXA1	H.33
268271	ECACD404B024W	A.9	268874	ECFA202S	A.11	269332	ECML2DS048	A.12	403128	6KGP43050X9XBXA1	H.33
268272	ECACD404B036W	A.9	268881	ECFA440S	A.11	269333	ECML2DS072	A.12	403129	6KGP43060X9XBXA1	H.33
268273	ECACD404B048W	A.9	268882	ECFA431S	A.11	269334	ECML2DS277	A.12	403130	6KGP43075X9XBXA1	H.33
268274	ECACD404B060W	A.9	268883	ECFA422S	A.11	269335	ECML2DS250	A.12	403131	6KGP43100X9XBXA1	H.33
268275	ECACD404B072W	A.9	268884	ECFA413S	A.11	269336	ECML2DS440	A.12	403132	6KGP43125X8XBXA1	H.33
268276	ECACD404B110W	A.9	268885	ECFA404S	A.11	400000			403133	6KGP43150X8XBXA1	H.33
268277	ECACD404B125W	A.9	268886	ECFA422SE	A.11	400412	6KGP43F50X9XXXA1	H.34	403134	6KGP43200X8XBXA1	H.33
268278	ECACD404B230W	A.9	268899	ECLA220S	A.11	400451	6KGP43001X9XXXA1	H.34	403135	6KGP43250X8XBXA1	H.33
268279	ECACD404B250W	A.9	268900	ECLA211S	A.11	401000			403136	6KGP43300X8XBXA1	H.33
268280	ECACD404B440W	A.9	268901	ECLA202S	A.11	401212	6KGP43002X9XXXA1	H.34	403137	6KGP43350X8XBXA1	H.33
268281	ECACD404B024L	A.9	268908	ECMI	A.11	401362	6KGP43003X9XXXA1	H.34	403138	6KGP43450X8XBXA1	H.33
268282	ECACD404B048L	A.9	268910	ECMI02S	A.11	402000			403139	6KGP43500X8XBXA1	H.33
268283	ECACD404B110L	A.9	268913	ECPT305C	A.11	402735	6KGP43005X9XXXA1	H.34	403140	6KGP43550X8XBXA1	H.33
268284	ECACD404B230L	A.9	268914	ECPT605C	A.11	402738	6KGP43007X9XXXA1	H.34	403141	6KGP43600X1XBXA1	H.33
268400	ECACD413B012W	A.9	268916	ECPT305D	A.11	402746	6KGP43010X9XXXA1	H.34	403142	6KGP43650X1XBXA1	H.33
268401	ECACD413B024W	A.9	268917	ECPT605D	A.11	402747	6KGP43015X9XXXA1	H.34	403143	6KGP43750X1XBXA1	H.33
268402	ECACD413B036W	A.9	268919	ECML1AS032	A.12	402748	6KGP43020X9XXXA1	H.34	403144	6KGP43900X1XBXA1	H.33
268403	ECACD413B048W	A.9	268920	ECML1AS060	A.12	402765	6KGP43025X9XXXA1	H.34	403145	6KGP431K0X1XBXA1	H.33
268404	ECACD413B060W	A.9	268921	ECML1AS127	A.12	402766	6KGP43030X9XXXA1	H.34	403146	6KGP431K2X1XBXA1	H.33
268405	ECACD413B072W	A.9	268922	ECML1AS277	A.12	402767	6KGP43040X9XXXA1	H.34	403156	6KGP43F50X2XBXA1	H.35
268406	ECACD413B110W	A.9	268923	ECML1AS480	A.12	402768	6KGP43050X9XXXA1	H.34	403157	6KGP43001X2XBXA1	H.35
268407	ECACD413B125W	A.9	268924	ECML1AS660	A.12	402769	6KGP43060X9XXXA1	H.34	403158	6KGP43002X2XBXA1	H.35
268408	ECACD413B230W	A.9	268925	ECML2AS032	A.12	402857	6KGP43075X9XXXA1	H.34	403159	6KGP43003X2XBXA1	H.35
268409	ECACD413B250W	A.9	268926	ECML2AS060	A.12	402863	6KGP43100X9XXXA1	H.34	403160	6KGP43005X2XBXA1	H.35
268410	ECACD413B440W	A.9	268927	ECML2AS127	A.12	402864	6KGP43125X8XXXA1	H.34	403161	6KGP43007X2XBXA1	H.35
268411	ECACD413B024L	A.9	268928	ECML2AS277	A.12	402865	6KGP43150X8XXXA1	H.34	403162	6KGP43010X2XBXA1	H.35
268412	ECACD413B048L	A.9	268929	ECML2AS480	A.12	402866	6KGP43200X8XXXA1	H.34	403163	6KGP43015X2XBXA1	H.35
268413	ECACD413B110L	A.9	268930	ECML2AS660	A.12	402867	6KGP43250X8XXXA1	H.34	403164	6KGP43020X2XBXA1	H.35
268414	ECACD413B230L	A.9	268931	ECSURD1440	A.12	402868	6KGP43300X8XXXA1	H.34	403165	6KGP43025X2XBXA1	H.35
268673	ECACA40B575	A.9	268932	ECSURC048	A.12	402869	6KGP43350X8XXXA1	H.34	403166	6KGP43030X2XBXA1	H.35
268674	ECACA41B575	A.9	268933	ECSURC127	A.12	402870	6KGP43450X8XXXA1	H.34	403167	6KGP43040X2XBXA1	H.35
268675	ECACA42B575	A.9	268934	ECSURC250	A.12	402871	6KGP43500X8XXXA1	H.34	403168	6KGP43050X2XBXA1	H.35
268676	ECACA41B575	A.9	268935	ECSURC440	A.12	402872	6KGP43550X8XXXA1	H.34	403169	6KGP43060X2XBXA1	H.35
268677	ECACA40B575	A.9	268936	ECSURC600	A.12	402873	6KGP43600X1XXCA1	H.34	403170	6KGP43075X2XBXA1	H.35
268687	ECCS1A012S	A.10	268937	ECSUVA048	A.12	402874	6KGP43650X1XXCA1	H.34	403171	6KGP43100X2XBXA1	H.35
268688	ECCS1A024S	A.10	268938	ECSUVA127	A.12	402875	6KGP43750X1XXCA1	H.34	403172	6KGP43125X2XBXA1	H.35
268689	ECCS1A042S	A.10	268939	ECSUVA250	A.12	402876	6KGP43900X1XXCA1	H.34	403173	6KGP43150X2XBXA1	H.35
268690	ECCS1A048S	A.10	268940	ECSUVA440	A.12	402877	6KGP431K0X1XXCA1	H.34	403174	6KGP43200X2XBXA1	H.35
268691	ECCS1A110S	A.10	268941	ECSUVA600	A.12	402878	6KGP431K2X1XXCA1	H.34	403175	6KGP43250X2XBXA1	H.35
268692	ECCS1A120S	A.10	268942	ECBB1B2	A.13	402888	6KGP43F50X2XXXA1	H.36	403176	6KGP43300X2XBXA1	H.35
268693	ECCS1A208S	A.10	268943	EC3PP1B	A.13	402889	6KGP43001X2XXXA1	H.36	403177	6KGP43350X2XBXA1	H.35
268694	ECCS1A230S	A.10	268944	EC4PP1B	A.13	402890	6KGP43002X2XXXA1	H.36	403178	6KGP43450X2XBXA1	H.35
268695	ECCS1A240S	A.10	268945	ECBB2B2	A.13	402891	6KGP43003X2XXXA1	H.36	403179	6KGP43500X2XBXA1	H.35
268696	ECCS1A400S	A.10	268946	EC3PP2B	A.13	402892	6KGP43005X2XXXA1	H.36	403180	6KGP43550X2XBXA1	H.35
268697	ECCS1A440S	A.10	268947	EC4PP2B	A.13	402893	6KGP43007X2XXXA1	H.36	403181	6KGP43600X2XBXA1	H.35
268698	ECCS1A480S	A.10	268948	ECKS1RV	A.13	402894	6KGP43010X2XXXA1	H.36	403182	6KGP43650X2XBXA1	H.35
268699	ECCS1A500S	A.10	268950	ECKS2RV	A.13	402895	6KGP43015X2XXXA1	H.36	403183	6KGP43750X2XBXA1	H.35
268700	ECCS1A600S	A.10	268951	ECKS1YD	A.13	402896	6KGP43020X2XXXA1	H.36	403184	6KGP43900X2XBXA1	H.35
268701	ECCS1D012S	A.10	268952	ECKS2YD	A.13	402897	6KGP43025X2XXXA1	H.36	403185	6KGP431K0X2XBXA1	H.35
268702	ECCS1D024S	A.10	268953	ECBP55	A.13	402898	6KGP43030X2XXXA1	H.36	403186	6KGP431K2X2XBXA1	H.35
268703	ECCS1D036S	A.10	268954	ECM1AL25	A.13	402899	6KGP43040X2XXXA1	H.36	403187	6KGP43F50X4XBXA1	H.37
268704	ECCS1D048S	A.10	268955	ECM1AL32	A.13	402900	6KGP43050X2XXXA1	H.36	403188	6KGP43001X4XBXA1	H.37
268705	ECCS1D060S	A.10	268956	ECM2AL40	A.13	402901	6KGP43060X2XXXA1	H.36	403189	6KGP43002X4XBXA1	H.37
268706	ECCS1D072S	A.10	268962	ECBP45	A.13	402902	6KGP43075X2XXXA1	H.36	403190	6KGP43003X4XBXA1	H.37
268707	ECCS1D110S	A.10	268963	ECRT1B5	A.14	402903	6KGP43100X2XXXA1	H.36	403191	6KGP43005X4XBXA1	H.37
268708	ECCS1D125S	A.10	268964	ECRT2B5	A.14	402909	6KGP43350X2XXCA1	H.36	403192	6KGP43007X4XBXA1	H.37
268709	ECCS1D230S	A.10	268984	ECCS1A575S	A.10	402910	6KGP43450X2XXCA1	H.36	403193	6KGP43010X4XBXA1	H.37
268710	ECCS1D250S	A.10	268985	ECCS2A575S	A.10	402911	6KGP43500X2XXCA1	H.36	403194	6KGP43015X4XBXA1	H.37
268711	ECCS1D440S	A.10	268996	ECRT1B10B	A.14	402912	6KGP43550X2XXCA1	H.36	403195	6KGP43020X4XBXA1	H.37
268712	ECCS1D0245L	A.10	268997	ECRT1B10C	A.14	402913	6KGP43600X2XXCA1	H.36	403196	6KGP43025X4XBXA1	H.37
268713	ECCS1D0485L	A.10	268998	ECRT1B10D	A.14	402914	6KGP43650X2XXCA1	H.36	403197	6KGP43030X4XBXA1	H.37
268714	ECCS1D1105L	A.10	268999	ECRT1B10F	A.14	402915	6KGP43750X2XXCA1	H.36	403198	6KGP43040X4XBXA1	H.37
268715	ECCS1D2305L	A.10	269000			402916	6KGP43900X2XXCA1	H.36	403199	6KGP43050X4XBXA1	H.37
268716	ECCS2A012S	A.10	269000	ECRT1B10G	A.14	402917	6KGP431K0X2XXCA1	H.36	403200	6KGP43060X4XBXA1</	

Ref. no	Cat. no	Page	Ref. no	Cat. no	Page	Ref. no	Cat. no	Page	Ref. no	Cat. no	Page
403545	6KGP63015X1XXA1	H.34	403699	6KGP63750X2XBCA1	H.35	404695	6KFP23050X9XXXXA1	H.53	404834	NEMA1ACB4	H.39
403546	6KGP63020X1XXA1	H.34	403700	6KGP63900X2XBCA1	H.35	404696	6KFP23060X9XXXXA1	H.53	404835	NEMA1ACC3	H.39
403547	6KGP63025X1XXA1	H.34	403701	6KGP631K0X2XBCA1	H.35	404697	6KFP23001X2XXXXA1	H.54	404836	NEMA1ACC4	H.39
403548	6KGP63030X1XXA1	H.34	403702	6KGP631K1X2XBCA1	H.35	404698	6KFP23002X2XXXXA1	H.54	404845	OPC4XPED	H.41
403549	6KGP63040X1XXA1	H.34	403703	6KGP631K2X2XBCA1	H.35	404699	6KFP23003X2XXXXA1	H.54	404846	OPCCOVER4142	H.41
403550	6KGP63050X1XXA1	H.34	403704	6KGP631K3X2XBCA1	H.35	404700	6KFP23005X2XXXXA1	H.54	404847	OPCCOVER51	H.41
403551	6KGP63060X1XXA1	H.34	403855	6KFP43001X9XXXXA1	H.53	404701	6KFP23007X2XXXXA1	H.54	404848	OPCPDP	H.39
403552	6KGP63075X1XXA1	H.34	403856	6KFP43002X9XXXXA1	H.53	404702	6KFP23010X2XXXXA1	H.54	404849	OPCRLV	H.40
403553	6KGP63100X1XXA1	H.34	403857	6KFP43003X9XXXXA1	H.53	404703	6KFP23015X2XXXXA1	H.54	404850	OPCRMKNC	H.39
403554	6KGP63125X8XXXXA1	H.34	403858	6KFP43005X9XXXXA1	H.53	404704	6KFP23020X2XXXXA1	H.54	404851	RMKYPDAC	H.56
403555	6KGP63150X8XXXXA1	H.34	403859	6KFP43007X9XXXXA1	H.53	404705	6KFP23025X2XXXXA1	H.54	404852	OPCRECS	H.40
403556	6KGP63200X8XXXXA1	H.34	403860	6KFP43010X9XXXXA1	H.53	404706	6KFP23030X2XXXXA1	H.54	404860	OPCUSB6X	H.41
403557	6KGP63250X8XXXXA1	H.34	403861	6KFP43015X9XXXXA1	H.53	404707	6KFP23040X2XXXXA1	H.54	404861	OPCUSB	H.41
403558	6KGP63300X8XXXXA1	H.34	403862	6KFP43020X9XXXXA1	H.53	404708	6KFP23050X2XXXXA1	H.54	720000		
403559	6KGP63350X8XXXXA1	H.34	403863	6KFP43025X9XXXXA1	H.53	404709	6KFP23060X2XXXXA1	H.54	720003		A.77
403560	6KGP63400X8XXXXA1	H.34	403864	6KFP43030X9XXXXA1	H.53	404710	6KFP23070X2XXXXA1	H.54	720004		A.77
403561	6KGP63500X8XXXXA1	H.34	403865	6KFP43040X9XXXXA1	H.53	404711	6KGP23F50X2XXXXA1	H.36	720005		A.77
403562	6KGP63550X8XXXXA1	H.34	403866	6KFP43050X9XXXXA1	H.53	404712	6KGP23001X2XXXXA1	H.36	720006		A.77
403563	6KGP63650X8XXXXA1	H.34	403867	6KFP43060X9XXXXA1	H.53	404713	6KGP23002X2XXXXA1	H.36	720007		A.77
403564	6KGP63750X8XXXXA1	H.34	403868	6KFP43075X9XXXXA1	H.53	404714	6KGP23003X2XXXXA1	H.36	720020		A.77
403565	6KGP63900X1XXCA1	H.34	403869	6KFP43100X9XXXXA1	H.53	404715	6KGP23005X2XXXXA1	H.36	720022		A.77
403566	6KGP631K0X1XXCA1	H.34	403870	6KFP43125X9XXXXA1	H.53	404716	6KGP23007X2XXXXA1	H.36	720023		A.77
403567	6KGP631K1X1XXCA1	H.34	403871	6KFP43150X8XXXXA1	H.53	404717	6KGP23010X2XXXXA1	H.36	720024		A.77
403568	6KGP631K2X1XXCA1	H.34	403872	6KFP43200X8XXXXA1	H.53	404718	6KGP23015X2XXXXA1	H.36	720025		A.77
403569	6KGP631K3X1XXCA1	H.34	403873	6KFP43250X8XXXXA1	H.53	404719	6KGP23020X2XXXXA1	H.36	720028		A.77
403581	6KGP63015X2XXXXA1	H.36	403874	6KFP43300X8XXXXA1	H.53	404720	6KGP23025X2XXXXA1	H.36	720029		A.77
403582	6KGP63020X2XXXXA1	H.36	403875	6KFP43350X8XXXXA1	H.53	404721	6KGP23030X2XXXXA1	H.36	720030		A.77
403583	6KGP63025X2XXXXA1	H.36	403876	6KFP43400X8XXXXA1	H.53	404722	6KGP23040X2XXXXA1	H.36	789000		
403584	6KGP63030X2XXXXA1	H.36	403877	6KFP43500X8XXXXA1	H.53	404723	6KGP23050X2XXXXA1	H.36	789174		E.4
403585	6KGP63040X2XXXXA1	H.36	403878	6KFP43550X8XXXXA1	H.53	404724	6KGP23F33X4XXXXA1	H.38	789175		E.4
403586	6KGP63050X2XXXXA1	H.36	403879	6KFP43600X8XXXXA1	H.53	404725	6KGP23F50X4XXXXA1	H.38	789176		E.4
403587	6KGP63060X2XXXXA1	H.36	403880	6KFP43650X1XXCA1	H.53	404726	6KGP23001X4XXXXA1	H.38	789177		E.4
403588	6KGP63075X2XXXXA1	H.36	403881	6KFP43750X1XXCA1	H.53	404727	6KGP23002X4XXXXA1	H.38	789178		E.4
403589	6KGP63100X2XXXXA1	H.36	403882	6KFP43900X1XXCA1	H.53	404728	6KGP23003X4XXXXA1	H.38	789179		E.4
403590	6KGP63125X2XXXXA1	H.36	403883	6KFP431K0X1XXCA1	H.53	404729	6KGP23005X4XXXXA1	H.38	789180		E.4
403591	6KGP63150X2XXXXA1	H.36	403884	6KFP431K2X1XXCA1	H.53	404730	6KGP23007X4XXXXA1	H.38	789181		E.4
403592	6KGP63200X2XXXXA1	H.36	403885	6KFP431K3X1XXCA1	H.53	404731	6KGP23010X4XXXXA1	H.38	789182		E.4
403593	6KGP63250X2XXXXA1	H.36	403886	6KFP43001X2XXXXA1	H.54	404732	6KGP23015X4XXXXA1	H.38	789183		E.4
403594	6KGP63300X2XXXXA1	H.36	403887	6KFP43002X2XXXXA1	H.54	404733	6KGP23020X4XXXXA1	H.38	789184		E.4
403595	6KGP63350X2XXXXA1	H.36	403888	6KFP43003X2XXXXA1	H.54	404734	6KGP23025X4XXXXA1	H.38	789185		E.4
403596	6KGP63400X2XXXXA1	H.36	403889	6KFP43005X2XXXXA1	H.54	404735	6KGP23030X4XXXXA1	H.38	789186		E.4
403597	6KGP63500X2XXXXA1	H.36	403890	6KFP43007X2XXXXA1	H.54	404736	6KGP23040X4XXXXA1	H.38	789187		E.4
403598	6KGP63550X2XXXXA1	H.36	403891	6KFP43010X2XXXXA1	H.54	404737	6KGP23050X4XXXXA1	H.38	789188		E.4
403599	6KGP63650X2XXXXA1	H.36	403892	6KFP43015X2XXXXA1	H.54	404738	6KGP631K6X1XBCA1	H.33	789189		E.4
403600	6KGP63750X2XXXXA1	H.36	403893	6KFP43020X2XXXXA1	H.54	404739	6KGP631K6X1XXCA1	H.34	789190		E.4
403601	6KGP63900X2XXXXA1	H.36	403894	6KFP43025X2XXXXA1	H.54	404740	6KGP631K6X2XBCA1	H.35	789191		E.4
403602	6KGP631K0X2XXCA1	H.36	403895	6KFP43030X2XXXXA1	H.54	404741	6KGP631K6X1XXCA1	H.36	789192		E.4
403603	6KGP631K1X2XXCA1	H.36	403896	6KFP43040X2XXXXA1	H.54	404742	6KLP21F25X9A1	H.25	789193		E.4
403604	6KGP631K2X2XXCA1	H.36	403897	6KFP43050X2XXXXA1	H.54	404743	6KLP21F50X9A1	H.25	789194		E.4
403605	6KGP631K3X2XXCA1	H.36	403898	6KFP43060X2XXXXA1	H.54	404744	6KLP21001X9A1	H.25	789195		E.4
403642	6KGP63015X1XBXA1	H.33	403899	6KFP43075X2XXXXA1	H.54	404745	6KLP21002X9A1	H.25	789196		E.5
403643	6KGP63020X1XBXA1	H.33	403900	6KFP43100X2XXXXA1	H.54	404746	6KLP21003X9A1	H.25	789197		E.5
403644	6KGP63025X1XBXA1	H.33	403901	6KFP43125X2XXXXA1	H.54	404747	6KLP23F33X9A1	H.25	789198		E.5
403645	6KGP63030X1XBXA1	H.33	403902	6KFP43150X2XXXXA1	H.54	404748	6KLP23F50X9A1	H.25	789199		E.5
403646	6KGP63040X1XBXA1	H.33	403903	6KFP43200X2XXXXA1	H.54	404749	6KLP23001X9A1	H.25	789200		E.5
403647	6KGP63050X1XBXA1	H.33	403904	6KFP43250X2XXXXA1	H.54	404750	6KLP23002X9A1	H.25	789201		E.5
403648	6KGP63060X1XBXA1	H.33	403905	6KFP43300X2XXXXA1	H.54	404751	6KLP23003X9A1	H.25	789202		E.5
403649	6KGP63075X1XBXA1	H.33	403906	6KFP43350X2XXXXA1	H.54	404752	6KLP23005X9A1	H.25	789203		E.5
403650	6KGP63100X1XBXA1	H.33	403907	6KFP43400X2XXXXA1	H.54	404753	6KLP43F50X9A1	H.25	789204		E.5
403651	6KGP63125X8XBBCA1	H.33	403908	6KFP43500X2XXXXA1	H.54	404754	6KLP43001X9A1	H.25	789205		E.5
403652	6KGP63150X8XBBCA1	H.33	403909	6KFP43550X2XXXXA1	H.54	404755	6KLP43002X9A1	H.25	789206		E.5
403653	6KGP63200X8XBBCA1	H.33	403910	6KFP43600X2XXXXA1	H.54	404756	6KLP43003X9A1	H.25	789207		E.5
403654	6KGP63250X8XBBCA1	H.33	403911	6KFP43650X2XXXXA1	H.54	404757	6KLP43005X9A1	H.25	789208		E.5
403655	6KGP63300X8XBBCA1	H.33	403912	6KFP43750X2XXXXA1	H.54	404758	6KLP43007X9A1	H.25	789209		E.5
403656	6KGP63350X8XBBCA1	H.33	403913	6KFP43900X2XXXXA1	H.54	404759	6KLP43010X9A1	H.25	789210		E.5
403657	6KGP63400X8XBBCA1	H.33	403914	6KFP431K0X2XXCA1	H.54	404792	6KLP43015X9A1	H.25	789211		E.5
403658	6KGP63500X8XBBCA1	H.33	403915	6KFP431K2X2XXCA1	H.54	404793	6KLP43020X9A1	H.25	789212		E.5
403659	6KGP63550X8XBBCA1	H.33	403916	6KFP431K3X2XXCA1	H.54	404794	6KLP43025X9A1	H.25	789213		E.5
403660	6KGP63650X8XBBCA1	H.33	404000			404795	6KLP43030X9A1	H.25	789214		E.5
403661	6KGP63750X8XBBCA1	H.33	404670	6KGP23F33X9XXXXA1	H.34	404796	KYPDACLP1	H.26	789215		E.5
403662	6KGP63900X1XBBCA1	H.33	404671	6KGP23F50X9XXXXA1	H.34	404797	RMKYPDACLP1	H.26	789216		E.5
403663	6KGP631K0X1XBBCA1	H.33	404672	6KGP23001X9XXXXA1	H.34	404798	NEMA1ACLP1	H.26	789217		E.5
403664	6KGP631K1X1XBBCA1	H.33	404673	6KGP23002X9XXXXA1	H.34	404799	NEMA1ACLP2	H.26	789218		E.5
403665	6KGP631K2X1XBBCA1	H.33	404674	6KGP23003X9XXXXA1	H.34	404800	NEMA1ACLP3	H.26	789219		E.5
403666	6KGP631K3X1XBBCA1	H.33	404675	6KGP23005X9XXXXA1	H.34	404801	NEMA1ACLP4	H.26	789220		E.5
403678	6KGP63015X2XBXA1	H.35	404676	6KGP23007X9XXXXA1	H.34	404802	NEMA1ACLP5	H.26	789221		E.5
403679	6KGP63020X2XBXA1	H.35	404677	6KGP23010X9XXXXA1	H.34	404803	DEPLTACLP3	H.26	789222		E.5
403682	6KGP63025X2XBXA1	H.35	404678	6KGP23015X9XXXXA1	H.34	404804	DEPLTACLP1	H.26	789223		E.5
403683	6KGP63030X2XBXA1	H.35	404679	6KGP23020X9XXXXA1	H.34	404805	DEPLTACLP2	H.26	789224		E.5
403684	6KGP63040X2XBXA1	H.35	404680	6KGP23025X9XXXXA1	H.34	404806	RMACLP1	H.26	789225		E.5
403685	6KGP63050X2XBXA1	H.35	404681	6KGP23030X9XXXXA1	H.34	404815	OPC24VPS	H.40	789226		E.5
403686	6KGP63060X2XBXA1	H.35	404682	6KGP23040X9XXXXA1	H.34	404816	OPCAIO	H.57	789227		E.5
403687	6KGP63075X2XBXA1	H.35	404683	6KGP23050X9XXXXA1	H.34	404817	OPCBAC	H.56	789228		E.5
403688	6KGP63100X2XBXA1	H.35	404684	6KFP23001X9XXXXA1	H.53	404818	OPCDEV	H.39	789229		E.5
403689	6KGP63125X2XBCA1	H.35	404685	6KFP23002X9XXXXA1	H.53	404819	OPCENC	H.40	789230		E.5
403690	6KGP63150X2XBCA1	H.35	404686	6KFP23003X9XXXXA1							

Ref. no	Cat. no	Page	Ref. no	Cat. no	Page	Ref. no	Cat. no	Page
789240		E.4	817311	GLIX07VCIC	J.6	817833	GLIX10HCC-B	J.6
789241		E.4	817312	GLIX10VCIC	J.6	817834	GLIX15HCC-B	J.6
789242		E.4	817313	GLIX15VCIC	J.6	817835	GLIX20HCC-B	J.6
789243		E.4	817314	GLIX20VCIC	J.6	817836	GLIX25HCC-B	J.6
789280		E.7	817315	GLIX25VCIC	J.6	817837	GLIX30HCC-B	J.6
789281		E.7	817316	GLIX30VCIC	J.6	817838	GLIX45HCC-B	J.6
789282		E.7	817317	GLIX45VCIC	J.6			
789283		E.7	817318	GLIX07HCIC	J.6			
789284		E.7	817319	GLIX10HCIC	J.6			
789285		E.7	817320	GLIX15HCIC	J.6			
789286		E.7	817321	GLIX20HCIC	J.6			
789287		E.7	817322	GLIX25HCIC	J.6			
789288		E.7	817323	GLIX30HCIC	J.6			
789289		E.7	817324	GLIX45HCIC	J.6			
789290		E.7	817325	GLIX07VCIC-B	J.6			
789291		E.7	817326	GLIX10VCIC-B	J.6			
789292		E.7	817327	GLIX15VCIC-B	J.6			
789293		E.7	817328	GLIX20VCIC-B	J.6			
789294		E.7	817329	GLIX25VCIC-B	J.6			
789295		E.7	817330	GLIX30VCIC-B	J.6			
789296		E.7	817331	GLIX45VCIC-B	J.6			
789297		E.7	817332	GLIX07HCIC-B	J.6			
789298		E.7	817333	GLIX10HCIC-B	J.6			
789299		E.7	817334	GLIX15HCIC-B	J.6			
789300		E.7	817335	GLIX20HCIC-B	J.6			
789301		E.7	817336	GLIX25HCIC-B	J.6			
789302		E.7	817337	GLIX30HCIC-B	J.6			
789303		E.7	817338	GLIX45HCIC-B	J.6			
789304		E.7	817590		E.13			
789305		E.7	817600		E.13			
789306		E.7	817700	GLIN03KS	J.7			
789307		E.7	817701	GLIN06KS	J.7			
789308		E.7	817702	GLIN10KS	J.7			
789309		E.7	817703	GLIN15KS	J.7			
789310		E.7	817704	GLIX07KS	J.7			
789311		E.7	817705	GLIX10KS	J.7			
789312		E.7	817706	GLIX15KS	J.7			
789313		E.7	817707	GLIX20KS	J.7			
789314		E.7	817708	GLIX25KS	J.7			
789315		E.7	817709	GLIX30KS	J.7			
789316		E.7	817710	GLIX45KS	J.7			
789317		E.7	817711	GLIX07VS	J.6			
789318		E.7	817712	GLIX10VS	J.6			
789319		E.7	817713	GLIX15VS	J.6			
789320		E.7	817714	GLIX20VS	J.6			
789321		E.7	817715	GLIX25VS	J.6			
789322		E.7	817716	GLIX30VS	J.6			
789323		E.7	817717	GLIX45VS	J.6			
789324		E.7	817718	GLIX07HS	J.6			
789325		E.7	817719	GLIX10HS	J.6			
789326		E.7	817720	GLIX15HS	J.6			
789327		E.7	817721	GLIX20HS	J.6			
789328		E.7	817722	GLIX25HS	J.6			
789329		E.7	817723	GLIX30HS	J.6			
789330		E.7	817724	GLIX45HS	J.6			
789331		E.7	817725	GLIX07VS-B	J.6			
789332		E.7	817726	GLIX10VS-B	J.6			
789333		E.7	817727	GLIX15VS-B	J.6			
789334		E.7	817728	GLIX20VS-B	J.6			
789335		E.7	817729	GLIX25VS-B	J.6			
789336		E.7	817730	GLIX30VS-B	J.6			
789337		E.7	817731	GLIX45VS-B	J.6			
789338		E.7	817732	GLIX07HS-B	J.6			
789339		E.7	817733	GLIX10HS-B	J.6			
817000			817734	GLIX15HS-B	J.6			
817000	GLCMDM	J.7	817735	GLIX20HS-B	J.6			
817211	GLIX07VIC	J.6	817736	GLIX25HS-B	J.6			
817212	GLIX10VIC	J.6	817737	GLIX30HS-B	J.6			
817213	GLIX15VIC	J.6	817738	GLIX45HS-B	J.6			
817214	GLIX20VIC	J.6	817801	GLCB	J.7			
817215	GLIX25VIC	J.6	817803	GLIOB	J.7			
817216	GLIX30VIC	J.6	817806	GLCMDM	J.7			
817217	GLIX45VIC	J.6	817811	GLIX07VCC	J.6			
817218	GLIX07HIC	J.6	817812	GLIX10VCC	J.6			
817219	GLIX10HIC	J.6	817813	GLIX15VCC	J.6			
817220	GLIX15HIC	J.6	817814	GLIX20VCC	J.6			
817221	GLIX20HIC	J.6	817815	GLIX25VCC	J.6			
817222	GLIX25HIC	J.6	817816	GLIX30VCC	J.6			
817223	GLIX30HIC	J.6	817817	GLIX45VCC	J.6			
817224	GLIX45HIC	J.6	817818	GLIX07HCC	J.6			
817225	GLIX07VIC-B	J.6	817819	GLIX10HCC	J.6			
817226	GLIX10VIC-B	J.6	817820	GLIX15HCC	J.6			
817227	GLIX15VIC-B	J.6	817821	GLIX20HCC	J.6			
817228	GLIX20VIC-B	J.6	817822	GLIX25HCC	J.6			
817229	GLIX25VIC-B	J.6	817823	GLIX30HCC	J.6			
817230	GLIX30VIC-B	J.6	817824	GLIX45HCC	J.6			
817231	GLIX45VIC-B	J.6	817825	GLIX07VCC-B	J.6			
817232	GLIX07HIC-B	J.6	817826	GLIX10VCC-B	J.6			
817233	GLIX10HIC-B	J.6	817827	GLIX15VCC-B	J.6			
817234	GLIX15HIC-B	J.6	817828	GLIX20VCC-B	J.6			
817235	GLIX20HIC-B	J.6	817829	GLIX25VCC-B	J.6			
817236	GLIX25HIC-B	J.6	817830	GLIX30VCC-B	J.6			
817237	GLIX30HIC-B	J.6	817831	GLIX45VCC-B	J.6			
817238	GLIX45HIC-B	J.6	817832	GLIX07HCC-B	J.6			

By reference number

Intro

B

B

C

D

E

F

G

H

I

J/X

The policy of GE Industrial Solutions is one of continuous improvement. The right is reserved to alter the design or any structural details of the products at any time without giving notice.

October 2012  
GE Industrial Solutions







GE Industrial Solutions is a first class global supplier of low and medium voltage products including wiring devices, residential and industrial electrical distribution components, automation products, enclosures and switchboards. Demand for the company's products comes from wholesalers, installers, panelboard builders, contractors, OEMs and utilities worldwide.

[www.ge.com/ex/industrialsolutions](http://www.ge.com/ex/industrialsolutions)  
[www.ge.com/uk/industrialsolutions](http://www.ge.com/uk/industrialsolutions)

**Belgium**

GE Industrial Belgium  
Nieuwevaart 51  
B-9000 Gent  
Tel. +32 (0)9 265 21 11

**Finland**

GE Industrial Solutions  
Kuortaneenkatu 2  
FI-00510 Helsinki  
Tel. +358 (0)10 394 3760

**France**

GE Industrial Solutions  
Paris Nord 2  
13, rue de la Perdrix  
F-95958 Roissy CDG Cédex  
Tel. +33 (0)800 912 816

**Germany**

GE Industrial Solutions  
Robert-Bosch Str. 2a  
D-50354 Hürth-Efferen  
Tel. +49 (0) 2233/ 9719-0

**Hungary**

GE Hungary Kft.  
Váci ut 81-83.  
H-1139 Budapest  
Tel. +36 1 447 6050

**Italy**

GE Industrial Solutions  
Centro Direzionale Colleoni  
Via Paracelso 16  
Palazzo Andromeda B1  
I-20864 Agrate Brianza (MB)  
Tel. +39 039 637 3701

**Netherlands**

GE Industrial Solutions  
Parallelweg 10  
NL-7482 CA Haaksbergen  
Tel. +31 (0)53 573 03 03

**Poland**

GE Power Controls  
Ul. Odrowaza 15  
03-310 Warszawa  
Tel. +48 22 519 76 00

**Portugal**

GE Industrial Solutions  
Rua Camilo Castelo Branco, 805  
Apartado 2770  
P-4401-601 Vila Nova de Gaia  
Tel. +351 22 374 60 00

**Russia**

GE Industrial Solutions  
27/8, Electrozavodskaya street  
Moscow, 107023  
Tel. +7 495 937 11 11

**South Africa**

GE Industrial Solutions  
130 Gazelle Avenue  
Corporate Park Midrand 1685  
P.O. Box 76672 Wendywood 2144  
Tel. +27 11 238 3000

**Spain**

GE Industrial Solutions  
P.I. Clot del Tufau, s/n  
E-08295 Sant Vicenç de Castellet  
Tel. +34 900 993 625

**United Arab Emirates**

GE Industrial Solutions  
Injaz Building, 3rd Floor  
Dubai Internet City  
PO Box 11549, Dubai  
Tel. +971 4 4546912

**United Kingdom**

GE Industrial Solutions  
Houghton Centre  
Salhouse Road  
Blackmills  
Northampton  
NN4 7EX  
Tel. +44 (0)800 587 1239

**Asia and Far East**

GE Industrial Solutions  
4F, Building 2, CTP, No1 Hua Tuo Rd.  
Zhang Jiang Hi-Tech Park  
Shanghai, China 201203  
Tel. +86 21 3877 7888

**Latin America**

GE Industrial Solutions  
790 N.W. 107th Avenue, Suite 200  
Miami, FL 33172 USA  
Tel. +1 305 551 5155

**North America**

GE Industrial Solutions  
41 Woodford Avenue  
Plainville CT, USA 06062  
and  
12305 Kurland Drive  
Houston, TX USA 77034  
Tel. +1 800-431-7867

GE Industrial Solutions  
Controls and Power Electronics

ED.04

# Controls and Power Electronics

ED.04

## For industrial applications



## X-ON Electronics

Largest Supplier of Electrical and Electronic Components

*Click to view similar products for [Industrial Relays](#) category:*

*Click to view products by [General Electric](#) manufacturer:*

Other Similar products are found below :

[6-1618400-7](#) [686-117111](#) [686-120111](#) [EV250-4A-02](#) [EV250-6A-01](#) [FCA-125-CX8](#) [FCA-410-138](#) [8-1618393-1](#) [GCA32A208VAC60HZ](#)  
[GCA32A220VAC50/60HZ](#) [GCA32A230VAC50/60HZ](#) [GCA32A240VAC50/60HZ](#) [GCA32A48VAC60HZ](#) [GCA63A120VAC50/60HZ](#)  
[GCA63A208VAC60HZ](#) [GCA63A220VAC60HZ](#) [GCA63A230VAC50/60HZ](#) [GCA63A240VAC50/60HZ](#) [GCA63A277VAC60HZ](#)  
[GCA63A48VAC60HZ](#) [GCA63A500VAC50/60HZ](#) [GCA63A600VAC60HZ](#) [GCA800A200VACDC](#) [GCA95A110VAC50/60HZ](#)  
[GCA95A120VAC50/60HZ](#) [GCA95A12VDC](#) [GCA95A240VAC50/60HZ](#) [GCA95A24VAC50/60HZ](#) [GCA95A48VAC60HZ](#) [ACC530U20](#)  
[ACC730U30](#) [1395832-1](#) [RM699BV-3011-85-1005](#) [RMIA210230AC](#) [RMIA45024AC](#) [1423675-8](#) [B07B032AC1-0329](#) [B329](#) [1617807-1](#)  
[N417](#) [P25-E5019-1](#) [P30C42A12D1-120](#) [2-1618398-1](#) [PBO-18A1218](#) [2307497](#) [RPYA00324LT](#) [RPYA003A120LT](#) [KR-4539-1](#)  
[RT334012WG](#) [S160156115](#)