

Silicon Standard Recovery Diode

$V_{RRM} = 100\text{ V} - 600\text{ V}$

$I_F = 300\text{ A}$

Features

- High Surge Capability
- Types up to 600 V V_{RRM}
- Not ESD Sensitive

DO-9 Package

Note:

1. Standard polarity: Stud is cathode.
2. Reverse polarity (R): Stud is anode.
3. Stud is base.

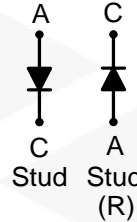

Maximum ratings, at $T_j = 25\text{ }^\circ\text{C}$, unless otherwise specified ("R" devices have leads reversed)

Parameter	Symbol	Conditions	S300B (R)	S300D (R)	S300E (R)	S300G (R)	S300J (R)	Unit
Repetitive peak reverse voltage	V_{RRM}		100	200	300	400	600	V
RMS reverse voltage	V_{RMS}		70	140	212	280	420	V
DC blocking voltage	V_{DC}		100	200	300	400	600	V
Continuous forward current	I_F	$T_C \leq 130\text{ }^\circ\text{C}$	300	300	300	300	300	A
Surge non-repetitive forward current, Half Sine Wave	$I_{F,SM}$	$T_C = 25\text{ }^\circ\text{C}$, $t_p = 8.3\text{ ms}$	6850	6850	6850	6850	6850	A
Operating temperature	T_j		-55 to 150	-55 to 150	-55 to 150	-55 to 150	-55 to 150	$^\circ\text{C}$
Storage temperature	T_{stg}		-55 to 150	-55 to 150	-55 to 150	-55 to 150	-55 to 150	$^\circ\text{C}$

Electrical characteristics, at $T_j = 25\text{ }^\circ\text{C}$, unless otherwise specified

Parameter	Symbol	Conditions	S300B (R)	S300D (R)	S300E (R)	S300G (R)	S300J (R)	Unit
Diode forward voltage	V_F	$I_F = 300\text{ A}$, $T_j = 25\text{ }^\circ\text{C}$	1.2	1.2	1.2	1.2	1.2	V
Reverse current	I_R	$V_R = 100\text{ V}$, $T_j = 25\text{ }^\circ\text{C}$	10	10	10	10	10	μA
		$V_R = 100\text{ V}$, $T_j = 175\text{ }^\circ\text{C}$	12	12	12	12	12	mA

Thermal characteristics

Parameter	Symbol	Conditions	S300B (R)	S300D (R)	S300E (R)	S300G (R)	S300J (R)	Unit
Thermal resistance, junction - case	R_{thJC}		0.16	0.16	0.16	0.16	0.16	$^\circ\text{C/W}$

Figure.1-Typical Forward Characteristics

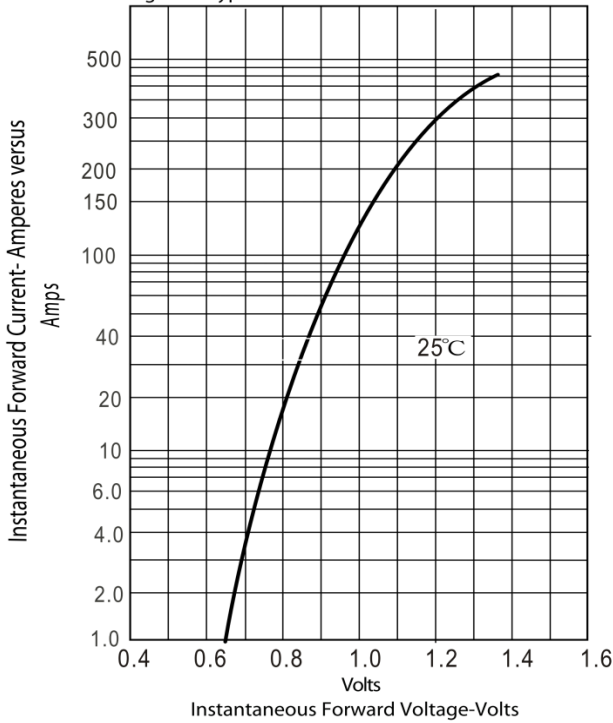

Figur.2-Forward Derating Curve

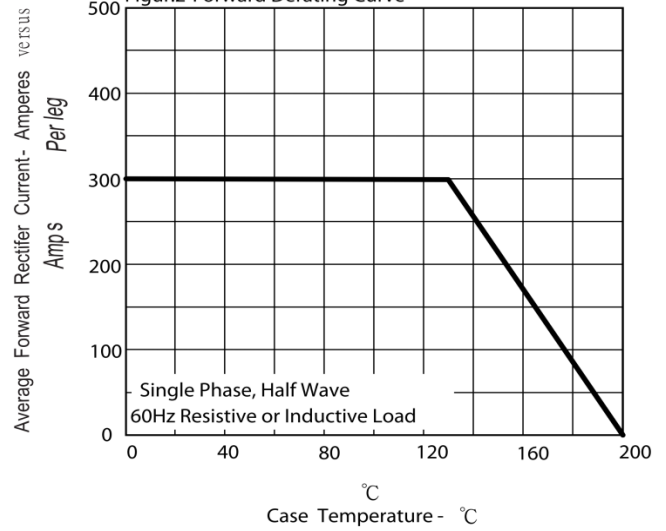
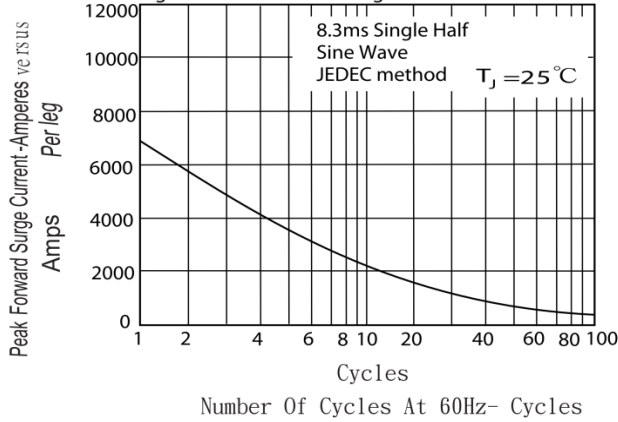
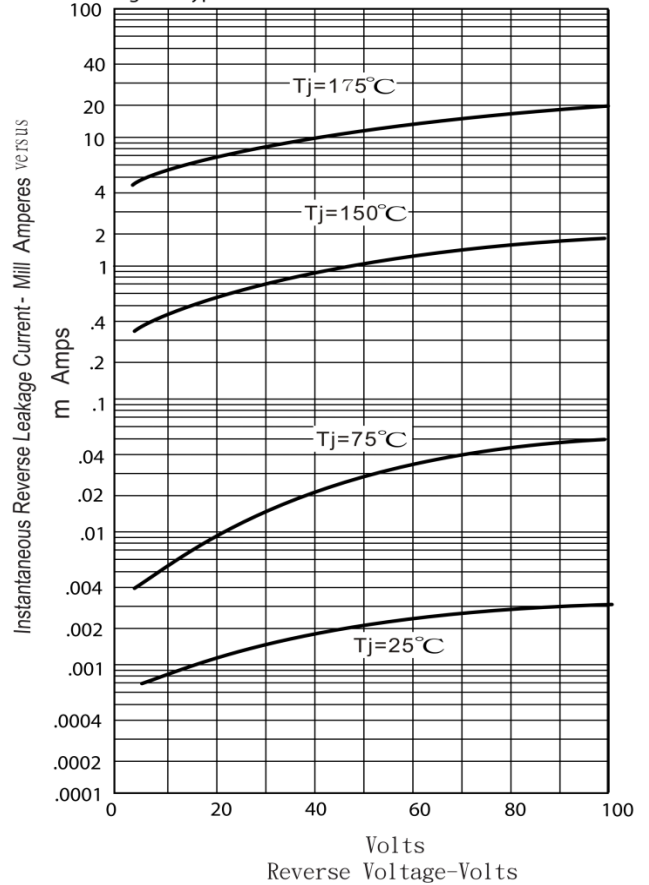

Figure.3-Peak Forward Surge Current



Figur.4-Typical Reverse Characteristics



Package dimensions and terminal configuration

Product is marked with part number and terminal configuration.

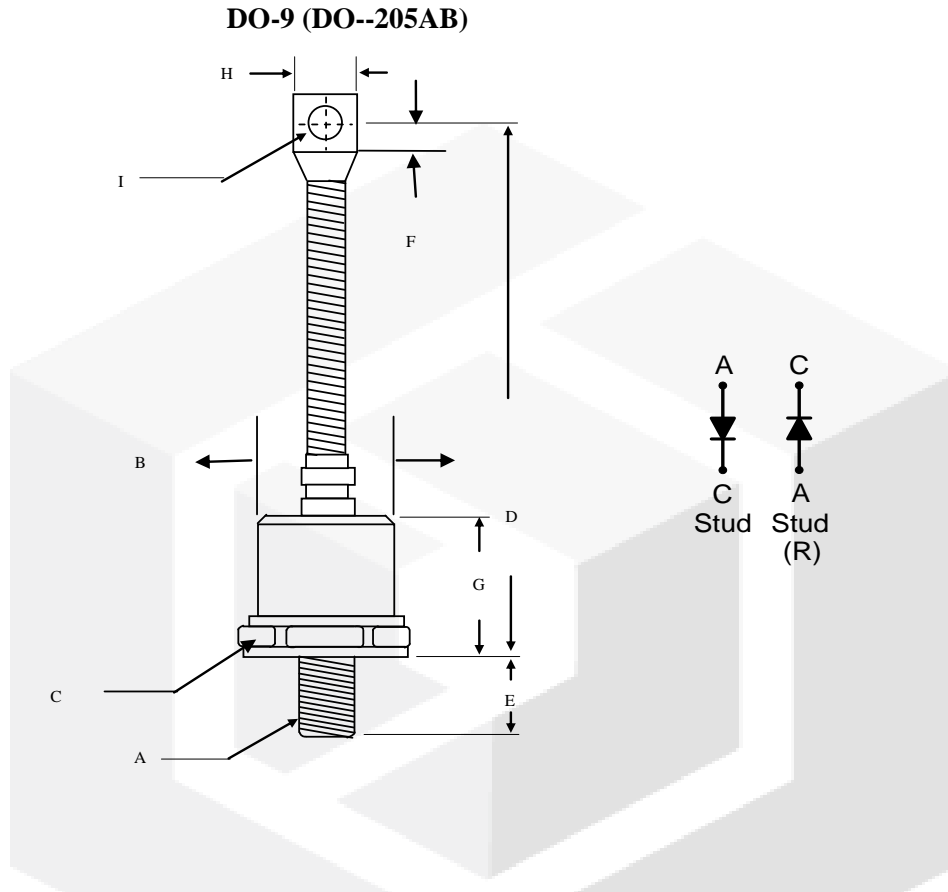

	Inches		Millimeters	
	Min	Max	Min	Max
A	3/4 - 16 UNF			
B	-----	1.10	-----	27.94
C	1.24	1.25	31.5	31.90
D	-----	7.48	-----	190.0
E	0.78	0.828	19.60	21.03
F	0.470	0.530	11.94	13.46
G	-----	1.122	-----	28.5
H	-----	0.787	-----	20.0
I	0.330	0.350	8.38	8.89

X-ON Electronics

Largest Supplier of Electrical and Electronic Components

Click to view similar products for [Rectifiers](#) category:

Click to view products by [GeneSiC Semiconductor](#) manufacturer:

Other Similar products are found below :

[70HFR40](#) [RL252-TP](#) [150KR30A](#) [1N5397](#) [SCF5000](#) [1N4002G](#) [1N4005-TR](#) [JANS1N6640US](#) [481235F](#) [RRE02VS6SGTR](#) [067907F](#) [MS306](#)
[70HF40](#) [T85HFL60S02](#) [VS-88-4031](#) [VS-66-9903](#) [US2JFL-TP](#) [A1N5404G-G](#) [ACGRA4007-HF](#) [ACGRB207-HF](#) [CLH03\(TE16L,Q\)](#)
[ACGRC307-HF](#) [ACEFC304-HF](#) [85HFR60](#) [40HFR60](#) [VS-88-7272PBF](#) [70HF120](#) [85HFR80](#) [D126A45C](#) [SCF7500](#) [D251N08B](#) [SCHJ22.5K](#)
[SM100](#) [SCPA2](#) [SCH10000](#) [SDHD5K](#) [VS-12FL100S10](#) [ACGRA4001-HF](#) [D1821SH45T PR](#) [D1251S45T](#) [SKN300/16](#) [SKN 5/08](#) [TSD3G](#)
[SET130312](#) [MSE07PBHM3/89A](#) [UES1106](#) [NTE6010](#) [JANTX1N5196](#) [SCHS15000](#) [BYV32-200M](#)