

承认书 Specifications		型 名 Type	GCDA252012P
		GLE 部品型号 GLE Part NO.	GCDA252012P 系列
接受 Accepted by		客户部品型号 Customer's Part No.	

外形寸法 Physical dimensions

单位 Unit: mm

RoHS Comp.

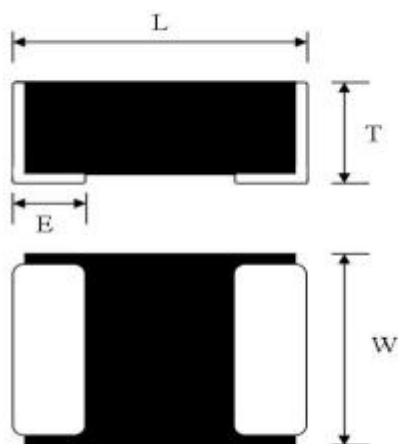

L [mm]	W [mm]	T [mm]	E [mm]
2.5±0.2	2.0±0.2	1.2 max.	0.6±0.3

使用材料 Materials

NO.	构成部品 Components	材质 Materials	原产国 Country of origin
1	磁性材料 Magnetic powder	金属合金粉末 Metal alloy powder	中国 China
2	铜线 Wire	改良聚胺脂涂布铜线 Polyurethane-system coated copper wire	德国 Germany
3	电极 Electrode	铜镀锡 Tinned copper	中国 China

Issued	2018.09.27			
记号 Symbol	日期 Date	页 Page	变更内容 Contents of revision	确认 Check



深圳市格莱尔电子有限公司
 Shenzhen Glorious Electronic Co.,Ltd.
 TEL: 0755-27815501-5503 / 29305001-5003
 FAX: 0755-27815500 / 29305500

承认者
Approved by

审查者
Checked by

担当者
Made by

张立华

张顺均

刘子善

GCDA252012P Type 一般规格 General Specifications (1/3)

	项目 Item	规格 Specification	条件 Condition
1	电极强度 Terminal Strength	No electrode detachment should be found	电感的电极焊在基板上，在 X.Z 方向用 5.0N 的静荷重加压 10 ± 2 秒。 When the device is pushed in two directions of X and Z with the force of 5N for 10 ± 2 seconds after soldering between copper plate and the electrodes
2	回流焊耐热试验 Reflow test	Change from an initial value L : within $\pm 20\%$	峰值温度 Peak temp $240 \pm 5^\circ\text{C}$ $30 \pm 10\text{s}$ 试验板的厚度 0.8mm 以上，按上面条件通过两次热风炉。 The specimen shall be subjected to the reflow process under the above condition 2 times. Test board shall be 0.8mm thick. Base material shall be glass epoxy resin. 测定 Measurement 常温常湿中放置于 1 小时以上测试。 The specimen shall be stored at standard atmospheric conditions for 1 h in prior to the measurement.
3	耐振性 Vibration	Change from an initial value L : within $\pm 20\%$	振动频率 10~55~10Hz，振幅 1.5mm，振动 1 小时。 The specimen shall be subjected to a vibration of 1.5mm amplitude, sweep frequency 10~55~10Hz after vibration for 1 hours
4	跌落实验 Free fall test	Change from an initial value L : within $\pm 20\%$	试件安装在基板上，由 1 米高自由落体，连续 10 次。 The specimen must be fixed on test board. Then it shall be fallen freely from 1m height. 10 consecutive times.
5	高温高湿试验 High temperature and high humidity test	Change from an initial value L : within $\pm 20\%$	在温度 $40 \pm 2^\circ\text{C}$ ，湿度 90~95% 中放置 96 ± 4 小时后，常温常湿中放置 1 小时以上 2 小时以内测试。 The specimen shall be stored at a temperature of $40 \pm 2^\circ\text{C}$ with relative humidity of 90 ~ 95% for $96 \pm 4\text{h}$. Then it shall be stabilized under standard atmospheric conditions for 1 h before measurement. Measurement shall be made within 1h~ 2h.

GCDA252012P Type 一般规格 General Specifications (2/3)

	项目 Item	规格 Specification	条件 Condition
6	高温保存试验 High temperature preservation test	Change from an initial value L : within $\pm 20\%$	在温度 $125 \pm 2^\circ\text{C}$ 中放置 96 ± 1 小时后, 常温常湿中放置 1 小时以上 2 小时以内测试。 The specimen shall be stored at a temperature of $125 \pm 2^\circ\text{C}$ for $96 \pm 1\text{h}$. Then it shall be stabilized under standard atmospheric conditions for 1 h before measurement. Measurement shall be made within 1h~ 2h.
7	低温保存试验 Low temperature preservation test	Change from an initial value L : within $\pm 20\%$	在温度 $-40 \pm 3^\circ\text{C}$ 中放置 96 ± 1 小时后, 常温常湿中放置 1 小时以上 2 小时以内测试。 After stored at a temperature of $-40 \pm 3^\circ\text{C}$ for $96 \pm 1\text{h}$. The specimen should be measured, then it should be measured under normal temperature and humidity in 1h~ 2h hours.
8	可焊性试验 Solder ability test	95% 以上的面积要被覆盖。 New solder shall cover 95% minimum of the surface immersed.	试验品的电极深布松香后, 焊锡槽温度 $260 \pm 5^\circ\text{C}$, 时间: 3 ± 0.5 秒。 Terminals shall be immersed in flux at room temperature. Dip sample into solder bath containing molten solder at $260 \pm 5^\circ\text{C}$ for 3 ± 0.5 seconds.
9	冷热冲击试验 Cold and hot cycle test	Change from an initial value L : within $\pm 20\%$	以温度 $-40 \pm 3^\circ\text{C}$ 中放置 30 分钟, 在 $125^\circ\text{C} \pm 2^\circ\text{C}$ 放置 30 分钟, 中间转换时间不超过 1 分钟为一个循环。完成 20 个循环后, 常温常湿中放置 1 小时以上 2 小时以内测试。 The specimen shall be measured after to 20 continuous cycles of temperature change of $-40^\circ\text{C} \pm 3^\circ\text{C}$ for 30 min and $125^\circ\text{C} \pm 2^\circ\text{C}$ for 30 min with the transit period of 2min or less. Then it shall be stabilized under standard atmospheric conditions for 1 h before measurement. Measurement shall be made within 1h~ 2h.
10	保存温湿度范围 Storage temperature and humidity range	temperature range: $5^\circ\text{C} \sim 35^\circ\text{C}$ humidity range: $25\% \sim 80\%$	在包装的状态下。 In packing state.

标准状态 Standard atmospheric conditions

Unless otherwise specified, the standard range of atmospheric conditions in making measurements and test as follows;

Ambient temperature : 5°C to 35°C , Relative humidity: 45% to 85%, Air pressure: 86kPa to 106kPa

If more strict measurement is required, measurement shall be made within following limits;

Ambient temperature : $20 \pm 2^\circ\text{C}$, Relative humidity: $65 \pm 5\%$, Air pressure: 86kPa to 106kPa

GCDA252012P Type 一般规格 General Specifications (3/3)

条件 Reflow soldering condition

- 回数: 2回
- Reflow times: 2times max
- We recommend infrared ray as heat source of reflow bath.
- However halogen lamp shall be used, side heat will be beyond range of resistance heat, so we can't recommend it.

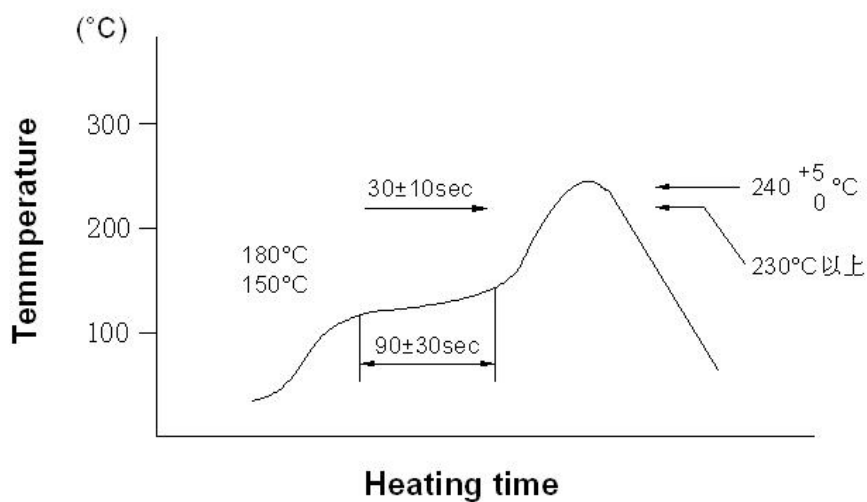

推荐焊盘寸法 Recommended PCB pattern

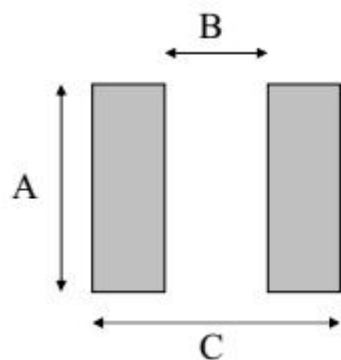

A [mm]	B [mm]	C [mm]
2.0	1.2	2.8.

GCDA252012P 捆包规格 Packing Specifications

Unit : mm

1. 寸法 Tape Dimensions

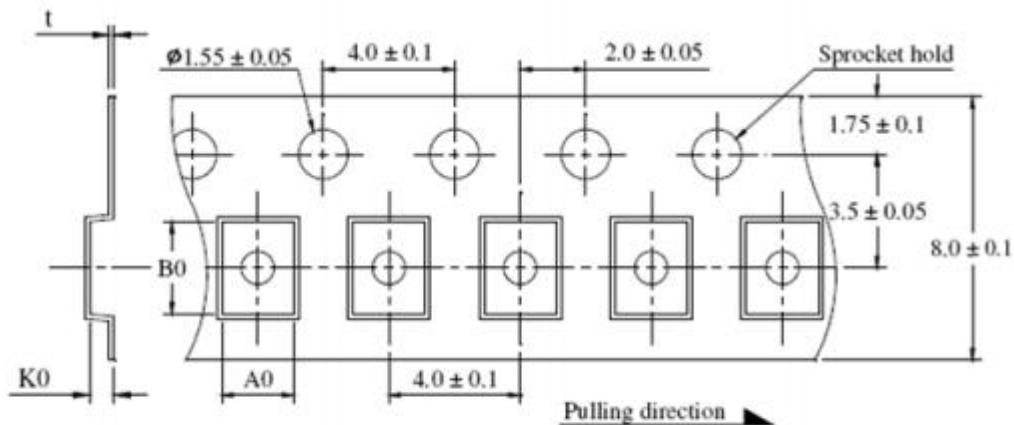

	A0	B0	K0	t
mm	2.25±0.05	2.80±0.1	1.35±0.1	0.22±0.05

2. 卷盘寸法图 Reel dimensions

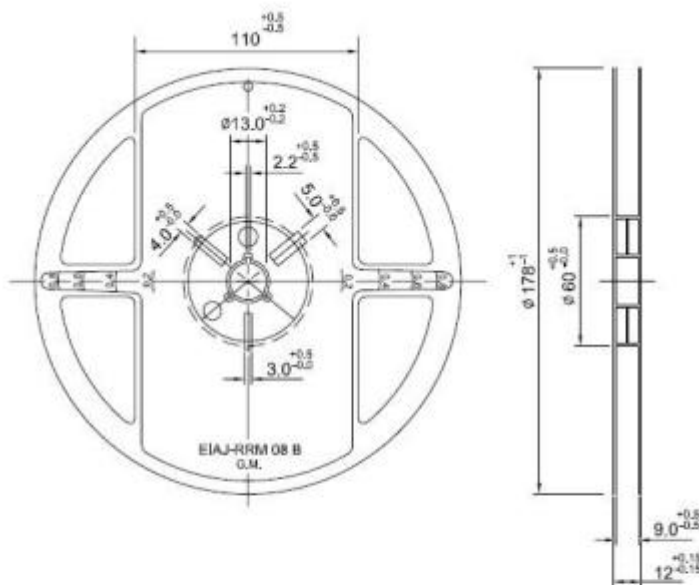

PART SIZE (EIA SIZE)	2520 (1008)
Qty.(pcs)	3,000
BOX	5 reels / inner box

禁用物质 Prohibited Substances

1. RoHS 规制的六种物质

- | | |
|------------|-------------------------------------|
| 1) 铅及其化合物 | Lead and its compounds |
| 2) 水银及其化合物 | Mercury and its inorganic compounds |
| 3) 镉及其化合物 | Cadmium and its compounds |
| 4) 六价铬化合物 | Hexavalent chromium compounds |
| 5) 多溴联苯 | PBB |
| 6) 多溴二苯醚 | PBDE |

2. 破坏臭氧层的化学物质使用限制

PROHIBITION TO USE OZONE DEPLETING SUBSTANCES (ODS)

- | 限制性物质 | Prohibited substances |
|----------------|-------------------------------------|
| 1) 氟氯化碳 | CFCS |
| 2) 氟哌丁苯 | Halon |
| 3) 四氯化碳 | Carbon tetrachloride |
| 4) 三氯乙烯 (三氯乙烷) | Trichloroethane (Methy1 chloroform) |

我公司保证我司的产品和生产过程符合“RoHS 规则”，所有产品中使用的材料均是化学物质生产规则中登记的材料。

We confirm that our products and our production process accord with "rule of RoHS". All materials used in this product are registered material under Regulation of Manufacture of Chemical Substances.

X-ON Electronics

Largest Supplier of Electrical and Electronic Components

Click to view similar products for [Fixed Inductors](#) category:

Click to view products by [GLE](#) manufacturer:

Other Similar products are found below :

[CR32NP-151KC](#) [CR32NP-180KC](#) [CR32NP-181KC](#) [CR32NP-1R5MC](#) [CR32NP-390KC](#) [CR32NP-3R9MC](#) [CR32NP-680KC](#) [CR32NP-820KC](#) [CR32NP-8R2MC](#) [CR43NP-390KC](#) [CR43NP-560KC](#) [CR43NP-680KC](#) [CR54NP-181KC](#) [CR54NP-470LC](#) [CR54NP-820KC](#) [CR54NP-8R5MC](#) [70F224AI](#) [MGDQ4-00004-P](#) [MHL1ECTTP18NJ](#) [MHQ1005P10NJ](#) [MHQ1005P1N0S](#) [MHQ1005P2N4S](#) [MHQ1005P3N6S](#) [MHQ1005P5N1S](#) [MHQ1005P8N2J](#) [PE-51506NL](#) [PE-53601NL](#) [PE-53602NL](#) [PE-53630NL](#) [PE-53824SNLT](#) [PE-92100NL](#) [PG0434.801NLT](#) [PG0936.113NLT](#) [9220-20](#) [9310-16](#) [PM06-2N7](#) [PM06-39NJ](#) [A01TK](#) [1206CS-471XJ](#) [HC2LP-R47-R](#) [HC2-R47-R](#) [HC3-2R2-R](#) [HCF1305-3R3-R](#) [1206CS-151XG](#) [RCH664NP-140L](#) [RCH664NP-4R7M](#) [RCH8011NP-221L](#) [RCP1317NP-332L](#) [RCP1317NP-391L](#) [RCR1010NP-470M](#)