

<b>承认书 Specifications</b>		型 名 Type	<b>GCNR4030</b>
		GLE 部品型号 GLE Part NO.	<b>GCNR4030 系列</b>
接受 Accepted by		客户部品型号 Customer's Part No.	

<b>外形寸法 Physical dimensions</b>	单位 Unit: mm	<b>RoHS Comp.</b>
---------------------------------	-------------	-------------------

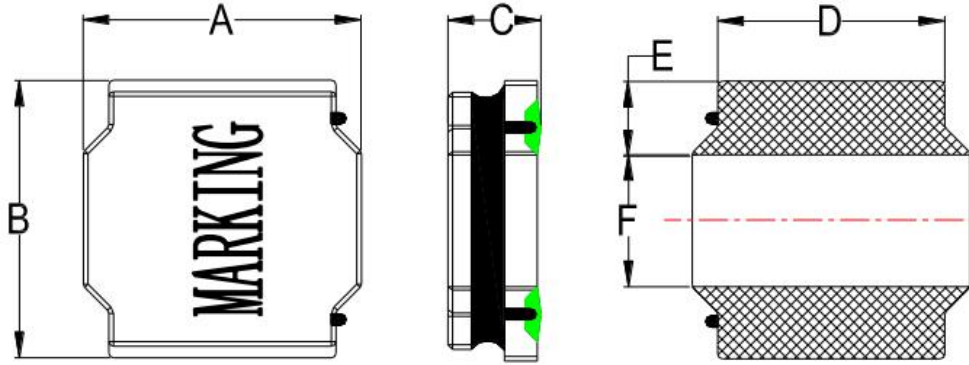

A	B	C	D	E	F
4.0±0.2	4.0±0.2	3.0+0.2/-0.3	3.3±0.2	0.95±0.2	2.1±0.2

**备注：黑色印字**

NO.	构成部品 Components	材质 Materials	原产国 Country of origin
1	磁性材料 Magnetic powder	镍锌铁氧体磁粉 Nickel zinc ferrite magnetic powder	中国 China
2	铜线 Wire	改良聚胺脂涂布铜线 Polyurethane-system coated copper wire	德国 Germany
3	磁胶 Magnetic epoxy resin	镍锌铁氧体磁粉+环氧树脂 Nickel zinc ferrite magnetic powder+ epoxy	中国 China
4	电极 Welding surface	锡 Sn	中国 China

Issued	2019.06.25			
记号 Symbol	日期 Date	页 Page	变更内容 Contents of revision	确认 Check

	<b>深圳市格莱尔电子有限公司</b> Shenzhen Glorious Electronic Co.,Ltd. TEL: 0755-27815501-5503 / 29305001-5003 FAX: 0755-27815500 / 29305500	承认者 Approved by  张立华	审查者 Checked by  张顺钧	担当者 Made by  刘子善
---	--	-------------------------------	------------------------------	---------------------------

<b>GCNR4030 Type 一般规格 General Specifications (1/3)</b>			
	项目 Item	规格 Specification	条件 Condition
1	电极强度 Terminal Strength	No electrode detachment should be found	电感的电极焊在基板上，在 X.Z 方向用 5.0N 的静荷重加压 $10 \pm 2$ 秒。 When the device is pushed in two directions of X and Z with the force of 5N for $10 \pm 2$ seconds after soldering between copper plate and the electrodes
2	回流焊耐热试验 Reflow test	Change from an initial value L : within $\pm 20\%$	峰值温度 Peak temp $240 \pm 5^\circ\text{C}$ $30 \pm 10\text{s}$ 试验板的厚度 0.8mm 以上，按上面条件通过两次热风炉。 The specimen shall be subjected to the reflow process under the above condition 2 times. Test board shall be 0.8mm thick. Base material shall be glass epoxy resin. 测定 Measurement 常温常湿中放置于 1 小时以上测试。 The specimen shall be stored at standard atmospheric conditions for 1 h in prior to the measurement.
3	耐振性 Vibration	Change from an initial value L : within $\pm 20\%$	振动频率 10~55~10Hz，振幅 1.5mm，振动 1 小时。 The specimen shall be subjected to a vibration of 1.5mm amplitude, sweep frequency 10~55~10Hz after vibration for 1 hours
4	跌落实验 Free fall test	Change from an initial value L : within $\pm 20\%$	试件安装在基板上，由 1 米高自由落体，连续 10 次。 The specimen must be fixed on test board. Then it shall be fallen freely from 1m height. 10 consecutive times.
5	高温高湿试验 High temperature and high humidity test	Change from an initial value L : within $\pm 20\%$	在温度 $40 \pm 2^\circ\text{C}$ ，湿度 90~95% 中放置 $96 \pm 4$ 小时后，常温常湿中放置 1 小时以上 2 小时以内测试。 The specimen shall be stored at a temperature of $40 \pm 2^\circ\text{C}$ with relative humidity of 90 ~ 95% for $96 \pm 4\text{h}$ . Then it shall be stabilized under standard atmospheric conditions for 1 h before measurement. Measurement shall be made within 1h~ 2h.

**GCNR4030 Type 一般规格 General Specifications (2/3)**

	项目 Item	规格 Specification	条件 Condition
6	高温保存试验 High temperature preservation test	Change from an initial value L : within $\pm 20\%$	在温度 $125 \pm 2^\circ\text{C}$ 中放置 $96 \pm 1$ 小时后, 常温常湿中放置 1 小时以上 2 小时以内测试。 The specimen shall be stored at a temperature of $125 \pm 2^\circ\text{C}$ for $96 \pm 1\text{h}$ . Then it shall be stabilized under standard atmospheric conditions for 1 h before measurement. Measurement shall be made within 1h~ 2h.
7	低温保存试验 Low temperature preservation test	Change from an initial value L : within $\pm 20\%$	在温度 $-40 \pm 3^\circ\text{C}$ 中放置 $96 \pm 1$ 小时后, 常温常湿中放置 1 小时以上 2 小时以内测试。 After stored at a temperature of $-40 \pm 3^\circ\text{C}$ for $96 \pm 1\text{h}$ . The specimen should be measured, then it should be measured under normal temperature and humidity in 1h~ 2h hours.
8	可焊性试验 Solder ability test	95% 以上的面积要被覆盖。 New solder shall cover 95% minimum of the surface immersed.	试验品的电极深布松香后, 焊锡槽温度 $260 \pm 5^\circ\text{C}$ , 时间: $3 \pm 0.5$ 秒。 Terminals shall be immersed in flux at room temperature. Dip sample into solder bath containing molten solder at $260 \pm 5^\circ\text{C}$ for $3 \pm 0.5$ seconds.
9	冷热冲击试验 Cold and hot cycle test	Change from an initial value L : within $\pm 20\%$	以温度 $-40 \pm 3^\circ\text{C}$ 中放置 30 分钟, 在 $125^\circ\text{C} \pm 2^\circ\text{C}$ 放置 30 分钟, 中间转换时间不超过 1 分钟为一个循环。完成 20 个循环后, 常温常湿中放置 1 小时以上 2 小时以内测试。 The specimen shall be measured after to 20 continuous cycles of temperature change of $-40^\circ\text{C} \pm 3^\circ\text{C}$ for 30 min and $125^\circ\text{C} \pm 2^\circ\text{C}$ for 30 min with the transit period of 2min or less. Then it shall be stabilized under standard atmospheric conditions for 1 h before measurement. Measurement shall be made within 1h~ 2h.
10	保存温湿度范围 Storage temperature and humidity range	temperature range: $5^\circ\text{C} \sim 35^\circ\text{C}$ humidity range: $25\% \sim 80\%$	在包装的状态下。 In packing state.

**标准状态 Standard atmospheric conditions**

Unless otherwise specified, the standard range of atmospheric conditions in making measurements and test as follows;

Ambient temperature :  $5^\circ\text{C}$  to  $35^\circ\text{C}$ , Relative humidity: 45% to 85%, Air pressure: 86kPa to 106kPa

If more strict measurement is required, measurement shall be made within following limits;

Ambient temperature :  $20 \pm 2^\circ\text{C}$ , Relative humidity:  $65 \pm 5\%$ , Air pressure: 86kPa to 106kPa

## GCMR4030 Type 一般规格 General Specifications (3/3)

### 条件 Reflow soldering condition

- 回数: 2回
- Reflow times: 2times max
- We recommend infrared ray as heat source of reflow bath.
- However halogen lamp shall be used, side heat will be beyond range of resistance heat, so we can't recommend it.

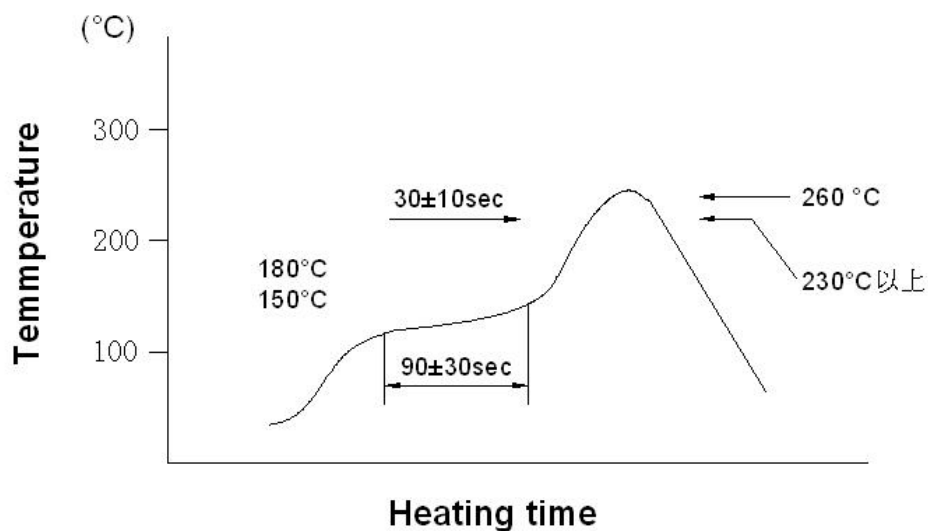

### 推荐焊盘寸法 Recommended PCB pattern

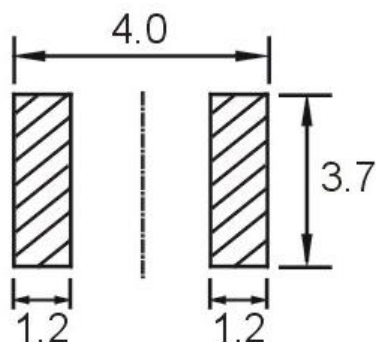

单位 Unit: mm

### GCMR4030 个别规格 Part Specifications

客户部品型号 Customer's Part No.	GLE 部品型号 GLE Part NO.	中心 InductanceLo (uH)	测定频率 Test Frequency (Hz/v)	直流阻抗 DC Resistance (mΩ)±30%	饱和电流 Isat (A) Max. ΔL/L ≤ -35%	温升电流 Irms (A) Max. ΔT ≤ 40℃
	GCMR4030-1R0M	1.0	100KHz/1v	14	5.26	4.15
	GCMR4030-1R5M	1.5	100KHz/1v	20	4.20	3.34
	GCMR4030-2R2M	2.2	100KHz/1v	30	3.80	2.95
	GCMR4030-3R3M	3.3	100KHz/1v	40	3.30	2.40
	GCMR4030-4R7M	4.7	100KHz/1v	60	2.90	2.00
	GCMR4030-6R8M	6.8	100KHz/1v	90	2.00	1.60
	GCMR4030-100M	10	100KHz/1v	100	1.85	1.50
	GCMR4030-150M	15	100KHz/1v	190	1.45	1.11
	GCMR4030-220M	22	100KHz/1v	225	1.30	1.00
	GCMR4030-330M	33	100KHz/1v	330	1.00	0.84
	GCMR4030-470M	47	100KHz/1v	445	0.80	0.72
	GCMR4030-680M	68	100KHz/1v	868	0.70	0.52
	GCMR4030-820M	82	100KHz/1v	1060	0.66	0.47
	GCMR4030-101M	100	100KHz/1v	1150	0.60	0.45

Note:  
 许容公差 Inductance Tolerance : (特性以实物为准)

- J = ±5%
- K = ±10%
- L = ±15%
- M = ± 20%
- N = ±30%

# GCNR4030 捆包规格 Packing Specifications

Unit : mm

## 1. 寸法 Tape Dimensions

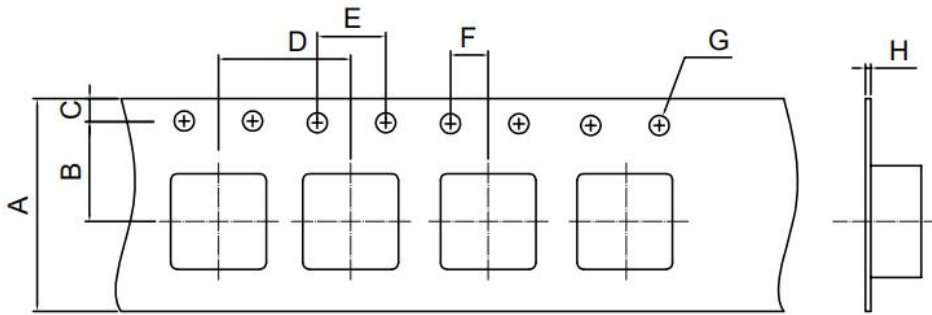

A	12.0
B	5.50
C	1.75
D	8.00
E	4.00
F	2.00
G	Ø1.50
H	0.30

## 2. 方法 Taping method 冷封 (The direction shall be seen from the top cover tape side.)

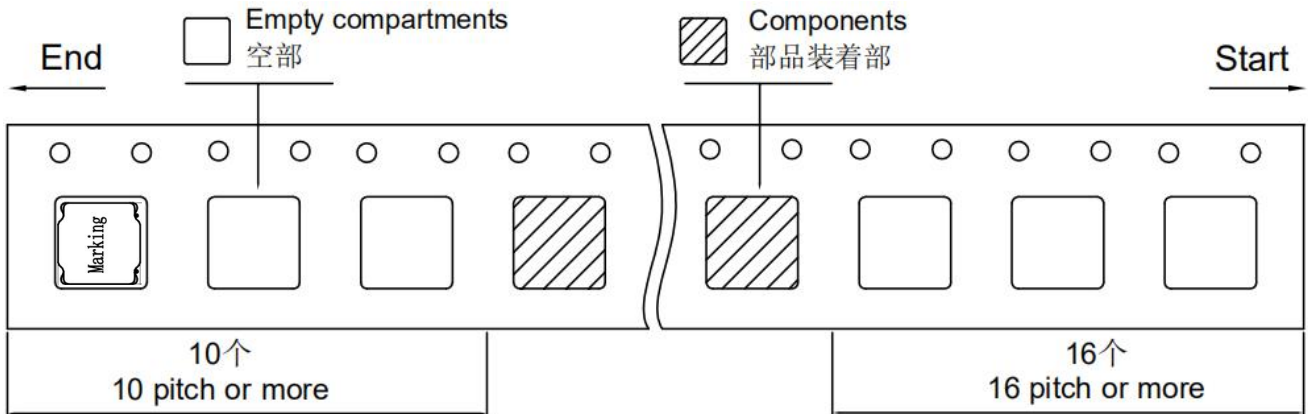

## 3. 卷盘寸法图 Reel dimensions

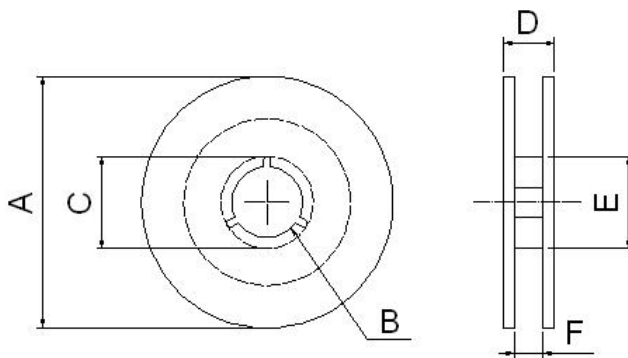

A	330.0
B	Ø13.0
C	21.0
D	16.4
E	100
F	12.4

## 4. 捆包箱 Packing box

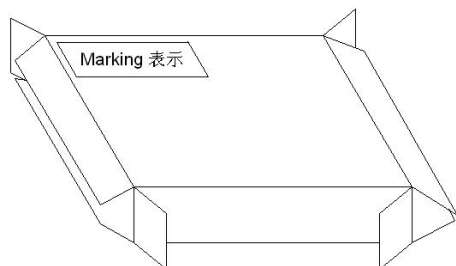

- 捆包箱材质 Packing case material  
纸 Kraft paper
- 收纳数 Real quantity per packing box  
4reel / 1box
- 数量/ 卷 Quantity : 2500PCS / reel
- 表示 Marking  
客户部品型号, 数量, Lot No.  
Customer's part number, Quantity, Lot number.

## 禁用物质 Prohibited Substances

### 1. RoHS 规制的六种物质

- |            |                                     |
|------------|-------------------------------------|
| 1) 铅及其化合物  | Lead and its compounds              |
| 2) 水银及其化合物 | Mercury and its inorganic compounds |
| 3) 镉及其化合物  | Cadmium and its compounds           |
| 4) 六价铬化合物  | Hexavalent chromium compounds       |
| 5) 多溴联苯    | PBB                                 |
| 6) 多溴二苯醚   | PBDE                                |

### 2. 破坏臭氧层的化学物质使用限制

#### PROHIBITION TO USE OZONE DEPLETING SUBSTANCES (ODS)

- | 限制性物质          | Prohibited substances               |
|----------------|-------------------------------------|
| 1) 氟氯化碳        | CFCS                                |
| 2) 氟哌丁苯        | Halon                               |
| 3) 四氯化碳        | Carbon tetrachloride                |
| 4) 三氯乙烯 (三氯乙烷) | Trichloroethane (Methy1 chloroform) |

我公司保证我司的产品和生产过程符合“RoHS 和 HF 规则”，所有产品中使用的材料均是化学物质生产规则中登记的材料。

We confirm that our products and our production process accord with "rule of RoHS&HF". All materials used in this product are registered material under Regulation of Manufacture of Chemical Substances.

## X-ON Electronics

Largest Supplier of Electrical and Electronic Components

*Click to view similar products for [Fixed Inductors](#) category:*

*Click to view products by [GLE manufacturer](#):*

Other Similar products are found below :

[MLZ1608M6R8WTD25](#) [MLZ1608N6R8LT000](#) [MLZ1608N3R3LTD25](#) [MLZ1608N3R3LT000](#) [MLZ1608N150LT000](#)  
[MLZ1608M150WTD25](#) [MLZ1608M3R3WTD25](#) [MLZ1608M3R3WT000](#) [MLZ1608M150WT000](#) [MLZ1608A1R5WT000](#)  
[MLZ1608N1R5LT000](#) [B82432C1333K000](#) [PCMB053T-1R0MS](#) [PCMB053T-1R5MS](#) [PCMB104T-1R5MS](#) [CR32NP-100KC](#) [CR32NP-151KC](#) [CR32NP-180KC](#) [CR32NP-181KC](#) [CR32NP-1R5MC](#) [CR32NP-390KC](#) [CR32NP-3R9MC](#) [CR32NP-680KC](#) [CR32NP-820KC](#)  
[CR32NP-8R2MC](#) [CR43NP-390KC](#) [CR43NP-560KC](#) [CR43NP-680KC](#) [CR54NP-181KC](#) [CR54NP-470LC](#) [CR54NP-820KC](#) [CR54NP-8R5MC](#)  
[MGDQ4-00004-P](#) [MGDU1-00016-P](#) [MHL1ECTTP18NJ](#) [MHL1JCTTD12NJ](#) [PE-51506NL](#) [PE-53601NL](#) [PE-53630NL](#) [PE-53824SNLT](#) [PE-62892NL](#) [PE-92100NL](#) [PG0434.801NLT](#) [PG0936.113NLT](#) [PM06-2N7](#) [PM06-39NJ](#) [HC2LP-R47-R](#) [HC2-R47-R](#) [HC3-2R2-R](#) [HC8-1R2-R](#)