

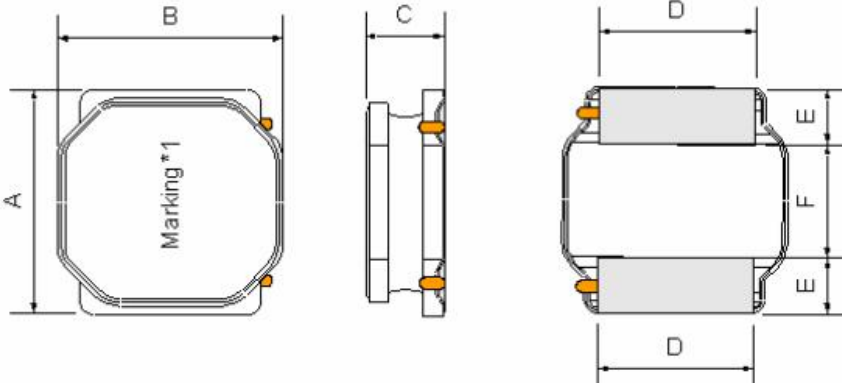

| | | | | | |
|---|---|--|------------------------------|--------------------|----------------|
| 承认书 Specifications | | 型 名 Type | | GCNR5040 | |
| | | GLE 部品型号 GLE Part NO. | | GCNR5040 系列 | |
| 接受 Accepted by | | 客户部品型号 Customer's Part No. | | | |
| 外形寸法 Physical dimensions | | | | 单位 Unit: mm | |
|  | | | | RoHS Comp. | |
| A | | B | | C | |
| 5.0±0.2 | | 5.0±0.2 | | 4.0+0.2/-0.3 | |
| D | | E | | F | |
| 4.0±0.2 | | 1.25±0.2 | | 2.5±0.2 | |
| 备注：黑色印字 | | | | | |
| NO. | 构成部品 Components | 材质 Materials | 原产国 Country of origin | | |
| 1 | 磁性材料 Magnetic powder | 镍锌铁氧体磁粉 Nickel zinc ferrite magnetic powder | 中国 China | | |
| 2 | 铜线 Wire | 改良聚胺脂涂布铜线 Polyurethane-system coated copper wire | 德国 Germany | | |
| 3 | 磁胶 Magnetic epoxy resin | 镍锌铁氧体磁粉+环氧树脂 Nickel zinc ferrite magnetic powder+ epoxy | 中国 China | | |
| 4 | 电极 Welding surface | 锡 Sn | 中国 China | | |
| Issued | 2019.06.25 | | | | |
| 记号 Symbol | 日期 Date | 页 Page | 变更内容 Contents of revision | | 确认 Check |
|  | 深圳市格莱尔电子有限公司 | | 承认者 Approved by | 审查者 Checked by | 担当者 Made by |
| | Shenzhen Glorious Electronic Co.,Ltd. TEL: 0755-27815501-5503 / 29305001-5003 FAX: 0755-27815500 / 29305500 | | 张立华 | 张顺钧 | 刘子善 |

| GCNR5040 Type 一般规格 General Specifications (1/3) | | | |
|--|---|---|--|
| | 项目 Item | 规格 Specification | 条件 Condition |
| 1 | 电极强度 Terminal Strength | No electrode detachment should be found | 电感的电极焊在基板上，在 X.Z 方向用 5.0N 的静荷重加压 10 ± 2 秒。 When the device is pushed in two directions of X and Z with the force of 5N for 10 ± 2 seconds after soldering between copper plate and the electrodes |
| 2 | 回流焊耐热试验 Reflow test | Change from an initial value L : within $\pm 20\%$ | 峰值温度 Peak temp $240 \pm 5^\circ\text{C}$ $30 \pm 10\text{s}$ 试验板的厚度 0.8mm 以上，按上面条件通过两次热风炉。 The specimen shall be subjected to the reflow process under the above condition 2 times. Test board shall be 0.8mm thick. Base material shall be glass epoxy resin. 测定 Measurement 常温常湿中放置于 1 小时以上测试。 The specimen shall be stored at standard atmospheric conditions for 1 h in prior to the measurement. |
| 3 | 耐振性 Vibration | Change from an initial value L : within $\pm 20\%$ | 振动频率 10~55~10Hz，振幅 1.5mm，振动 1 小时。 The specimen shall be subjected to a vibration of 1.5mm amplitude, sweep frequency 10~55~10Hz after vibration for 1 hours |
| 4 | 跌落实验 Free fall test | Change from an initial value L : within $\pm 20\%$ | 试件安装在基板上，由 1 米高自由落体，连续 10 次。 The specimen must be fixed on test board. Then it shall be fallen freely from 1m height. 10 consecutive times. |
| 5 | 高温高湿试验 High temperature and high humidity test | Change from an initial value L : within $\pm 20\%$ | 在温度 $40 \pm 2^\circ\text{C}$ ，湿度 90~95% 中放置 96 ± 4 小时后，常温常湿中放置 1 小时以上 2 小时以内测试。 The specimen shall be stored at a temperature of $40 \pm 2^\circ\text{C}$ with relative humidity of 90 ~ 95% for $96 \pm 4\text{h}$. Then it shall be stabilized under standard atmospheric conditions for 1 h before measurement. Measurement shall be made within 1h~ 2h. |

GCNR5040 Type 一般规格 General Specifications (2/3)

| | 项目 Item | 规格 Specification | 条件 Condition |
|----|---|--|--|
| 6 | 高温保存试验 High temperature preservation test | Change from an initial value L : within $\pm 20\%$ | 在温度 $125 \pm 2^\circ\text{C}$ 中放置 96 ± 1 小时后, 常温常湿中放置 1 小时以上 2 小时以内测试。 The specimen shall be stored at a temperature of $125 \pm 2^\circ\text{C}$ for $96 \pm 1\text{h}$. Then it shall be stabilized under standard atmospheric conditions for 1 h before measurement. Measurement shall be made within 1h~ 2h. |
| 7 | 低温保存试验 Low temperature preservation test | Change from an initial value L : within $\pm 20\%$ | 在温度 $-40 \pm 3^\circ\text{C}$ 中放置 96 ± 1 小时后, 常温常湿中放置 1 小时以上 2 小时以内测试。 After stored at a temperature of $-40 \pm 3^\circ\text{C}$ for $96 \pm 1\text{h}$. The specimen should be measured, then it should be measured under normal temperature and humidity in 1h~ 2h hours. |
| 8 | 可焊性试验 Solder ability test | 95% 以上的面积要被覆盖。 New solder shall cover 95% minimum of the surface immersed. | 试验品的电极深布松香后, 焊锡槽温度 $260 \pm 5^\circ\text{C}$, 时间: 3 ± 0.5 秒。 Terminals shall be immersed in flux at room temperature. Dip sample into solder bath containing molten solder at $260 \pm 5^\circ\text{C}$ for 3 ± 0.5 seconds. |
| 9 | 冷热冲击试验 Cold and hot cycle test | Change from an initial value L : within $\pm 20\%$ | 以温度 $-40 \pm 3^\circ\text{C}$ 中放置 30 分钟, 在 $125^\circ\text{C} \pm 2^\circ\text{C}$ 放置 30 分钟, 中间转换时间不超过 1 分钟为一个循环。完成 20 个循环后, 常温常湿中放置 1 小时以上 2 小时以内测试。 The specimen shall be measured after to 20 continuous cycles of temperature change of $-40^\circ\text{C} \pm 3^\circ\text{C}$ for 30 min and $125^\circ\text{C} \pm 2^\circ\text{C}$ for 30 min with the transit period of 2min or less. Then it shall be stabilized under standard atmospheric conditions for 1 h before measurement. Measurement shall be made within 1h~ 2h. |
| 10 | 保存温湿度范围 Storage temperature and humidity range | temperature range: $5^\circ\text{C} \sim 35^\circ\text{C}$ humidity range: $25\% \sim 80\%$ | 在包装的状态下。 In packing state. |

标准状态 Standard atmospheric conditions

Unless otherwise specified, the standard range of atmospheric conditions in making measurements and test as follows;

Ambient temperature : 5°C to 35°C , Relative humidity: 45% to 85%, Air pressure: 86kPa to 106kPa

If more strict measurement is required, measurement shall be made within following limits;

Ambient temperature : $20 \pm 2^\circ\text{C}$, Relative humidity: $65 \pm 5\%$, Air pressure: 86kPa to 106kPa

GCNR5040 Type 一般规格 General Specifications (3/3)

条件 Reflow soldering condition

- 回数: 2回
- Reflow times: 2times max
- We recommend infrared ray as heat source of reflow bath.
- However halogen lamp shall be used, side heat will be beyond range of resistance heat, so we can't recommend it.

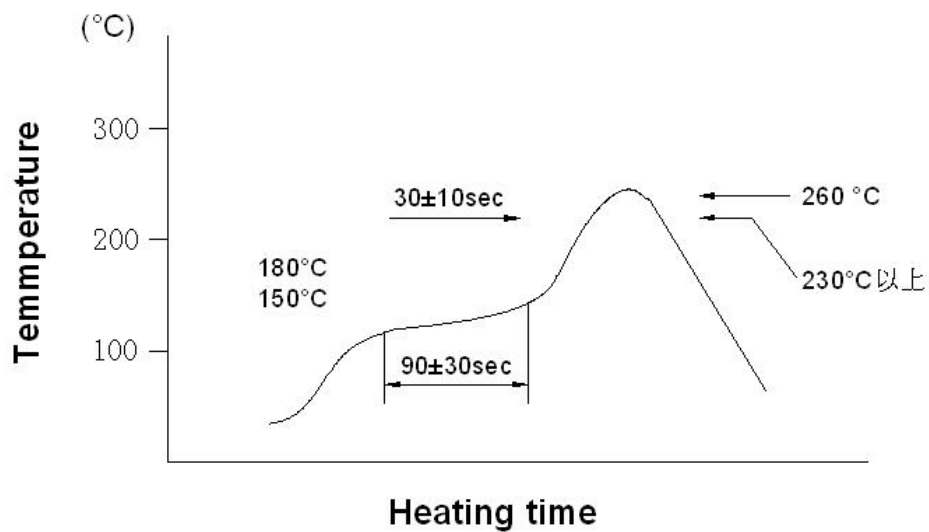

推荐焊盘寸法 Recommended PCB pattern

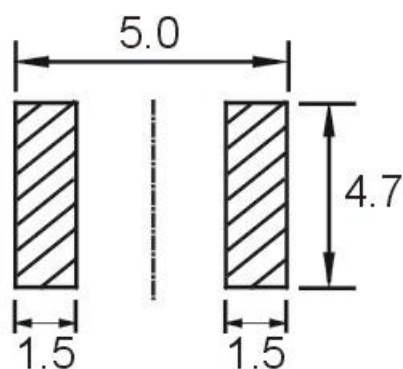

单位 Unit: mm

GCNR5040 捆包规格 Packing Specifications

Unit : mm

1. 寸法 Tape Dimensions

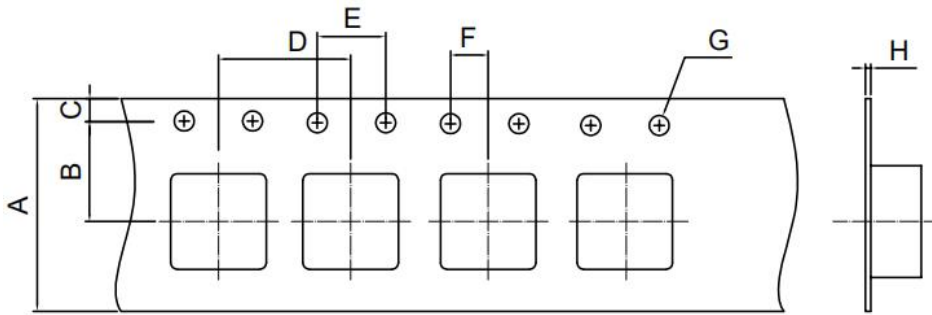

| | |
|---|-------|
| A | 12.0 |
| B | 5.50 |
| C | 1.75 |
| D | 8.00 |
| E | 4.00 |
| F | 2.00 |
| G | Ø1.50 |
| H | 0.35 |

2. 方法 Taping method 冷封 (The direction shall be seen from the top cover tape side.)

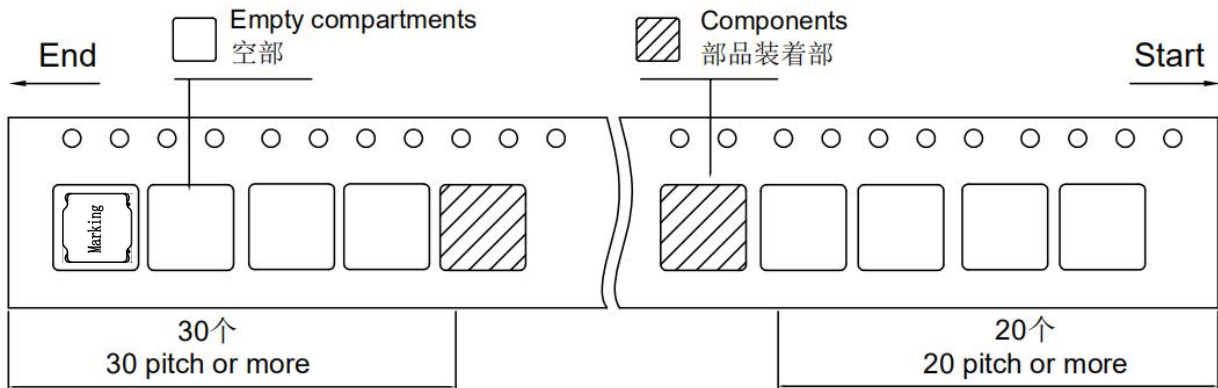

3. 卷盘寸法图 Reel dimensions

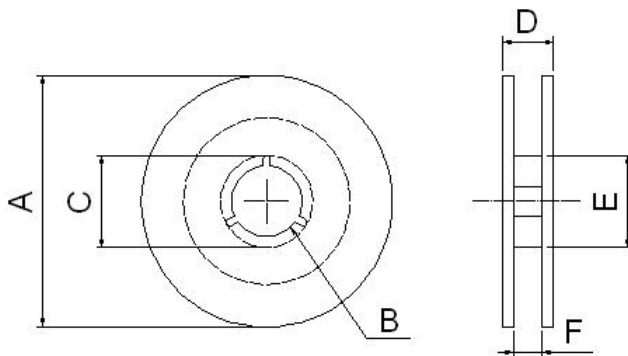

| | |
|---|-------|
| A | 330.0 |
| B | Ø13.0 |
| C | 21.0 |
| D | 16.4 |
| E | 100 |
| F | 12.4 |

4. 捆包箱 Packing box

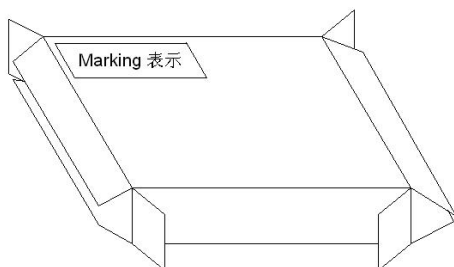

- 捆包箱材质 Packing case material
纸 Kraft paper
- 收纳数 Real quantity per packing box
4reel / 1box
- 数量/ 卷 Quantity : 1500PCS / reel
- 表示 Marking
客户部品型号, 数量, Lot No.
Customer's part number, Quantity, Lot number.

禁用物质 Prohibited Substances

1. RoHS 规制的六种物质

- | | |
|------------|-------------------------------------|
| 1) 铅及其化合物 | Lead and its compounds |
| 2) 水银及其化合物 | Mercury and its inorganic compounds |
| 3) 镉及其化合物 | Cadmium and its compounds |
| 4) 六价铬化合物 | Hexavalent chromium compounds |
| 5) 多溴联苯 | PBB |
| 6) 多溴二苯醚 | PBDE |

2. 破坏臭氧层的化学物质使用限制

PROHIBITION TO USE OZONE DEPLETING SUBSTANCES (ODS)

- | 限制性物质 | Prohibited substances |
|----------------|-------------------------------------|
| 1) 氟氯化碳 | CFCS |
| 2) 氟哌丁苯 | Halon |
| 3) 四氯化碳 | Carbon tetrachloride |
| 4) 三氯乙烯 (三氯乙烷) | Trichloroethane (Methy1 chloroform) |

我公司保证我司的产品和生产过程符合“RoHS 和 HF 规则”，所有产品中使用的材料均是化学物质生产规则中登记的材料。

We confirm that our products and our production process accord with "rule of RoHS&HF". All materials used in this product are registered material under Regulation of Manufacture of Chemical Substances.

X-ON Electronics

Largest Supplier of Electrical and Electronic Components

Click to view similar products for [Fixed Inductors](#) category:

Click to view products by [GLE manufacturer](#):

Other Similar products are found below :

[MLZ1608M6R8WTD25](#) [MLZ1608N6R8LT000](#) [MLZ1608N3R3LTD25](#) [MLZ1608N3R3LT000](#) [MLZ1608N150LT000](#)

[MLZ1608M150WTD25](#) [MLZ1608M3R3WTD25](#) [MLZ1608M3R3WT000](#) [MLZ1608M150WT000](#) [MLZ1608A1R5WT000](#)

[MLZ1608N1R5LT000](#) [B82432C1333K000](#) [PCMB053T-1R0MS](#) [PCMB053T-1R5MS](#) [PCMB104T-1R5MS](#) [CR32NP-100KC](#) [CR32NP-](#)

[151KC](#) [CR32NP-180KC](#) [CR32NP-181KC](#) [CR32NP-1R5MC](#) [CR32NP-390KC](#) [CR32NP-3R9MC](#) [CR32NP-680KC](#) [CR32NP-820KC](#)

[CR32NP-8R2MC](#) [CR43NP-390KC](#) [CR43NP-560KC](#) [CR43NP-680KC](#) [CR54NP-181KC](#) [CR54NP-470LC](#) [CR54NP-820KC](#) [CR54NP-8R5MC](#)

[MGDQ4-00004-P](#) [MGDU1-00016-P](#) [MHL1ECTTP18NJ](#) [MHL1JCTTD12NJ](#) [PE-51506NL](#) [PE-53601NL](#) [PE-53630NL](#) [PE-53824SNLT](#) [PE-](#)

[62892NL](#) [PE-92100NL](#) [PG0434.801NLT](#) [PG0936.113NLT](#) [PM06-2N7](#) [PM06-39NJ](#) [HC2LP-R47-R](#) [HC2-R47-R](#) [HC3-2R2-R](#) [HC8-1R2-R](#)