



# 050-113

## PRODUCT BRIEF

Media Converter, Dual or Single Channel, Panel Mount  
10/100/1000BASE-T to Fiber Optic Ethernet  
(1000BASE-SX, 1000 BASE-LX10 or 100BASE-FX), 28VDC,  
M38999 (Signal & Power), M38999 (Fiber Optic)

REV	DESCRIPTION	DATE	APPROVED
9	Preliminary	04/28/2016	MF/RAS
10	Add ECCN	05/26/2016	RAS
11	Update Absolute Maximum Voltage	01/10/2017	RAS/GC
12	Add Flow Control Option	03/31/2017	RAS/GC
13	Update Copyright date	05/23/2017	GC

BF13U2-xxxx

THIS COPYRIGHTED DOCUMENT IS THE PROPERTY OF GLENAIR, INC. AND IS FURNISHED ON THE CONDITION THAT IT IS NOT TO BE DISCLOSED, REPRODUCED IN WHOLE OR IN PART, OR USED TO SOLICIT QUOTATIONS FROM COMPETITIVE SOURCES, OR USED FOR MANUFACTURE BY ANYONE OTHER THAN GLENAIR, INC. WITHOUT WRITTEN PERMISSION FROM GLENAIR, INC. THE INFORMATION HEREIN HAS BEEN DEVELOPED AT GLENAIR'S EXPENSE AND MAY BE USED FOR ENGINEERING EVALUATION AND INCORPORATION INTO TECHNICAL SPECIFICATIONS AND OTHER DOCUMENTS WHICH SPECIFY PROCUREMENT OF PRODUCTS FROM GLENAIR, INC.

## 050-113 PRODUCT BRIEF

Media Converter, Single or Dual Channel, Panel Mount  
10/100/1000BASE-T to Fiber Optic Ethernet (SX, LX10 or FX)



### 10/100/1000BASE-T to 1000BASE-SX or 1000BASE-LX10

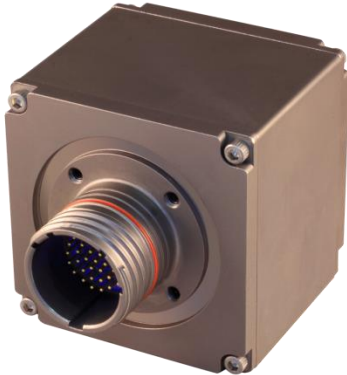

The Glenair 050-113 is a 10/100/1000BASE-T to Fiber Media converter that can be configured for 1 or 2 channels and can support conversion to 1000BASE-SX, 1000BASE-LX or 100BASE-FX protocols. It is designed for harsh environments and incorporates electronics in an environmentally sealed enclosure that incorporates two environmental M38999 connectors. One connector is utilized for power and electrical signal and the second connector is used for the Fiber Optic signals and can be configured to support either single mode or multi-mode fiber applications.

#### KEY FEATURES/BENEFITS

- 1310nm FP Lasers for 1000BASE-LX10
- InGaAs PIN PD for 1000BASE-LX10
- 850nm Lasers for 1000BASE-SX
- GaAs PIN PD for 1000BASE-SX
- 1300nm LED for 100BASE-FX
- PIN PD for 100BASE-FX
- Wide Input Voltage Range: 18-36V
- Electrical Interface compliant with IEEE 802.3 (10/100/1000BASE-T)
- Optical Interface compliant with IEEE 802.3 (1000BASE-LX10, 1000BASE-SX, 100BASE-FX)
- Wide Operating temperature: -40°C to +85°C
- Option to implement Flow Control

- Ethernet MDI/MDIX automatic crossover
- Magnetics on the electrical signal input side to support 10/100/1000BASE-T operation over 100m Cat 5E
- IP67 in mated condition
- M38999 Electrical Signal & Power
- M38999 Fiber Optic Connector
- Panel Mount, either J1 or J2

#### OPTIONAL FEATURES

- Built In Test Console Port accessible via USB2.0
- Built in Test Console Port accessible via UART

#### APPLICATIONS

- Harsh Environment such as: Airborne, Tactical, Railway, Industrial, Oil and Gas and Shipboard applications

#### How To Order

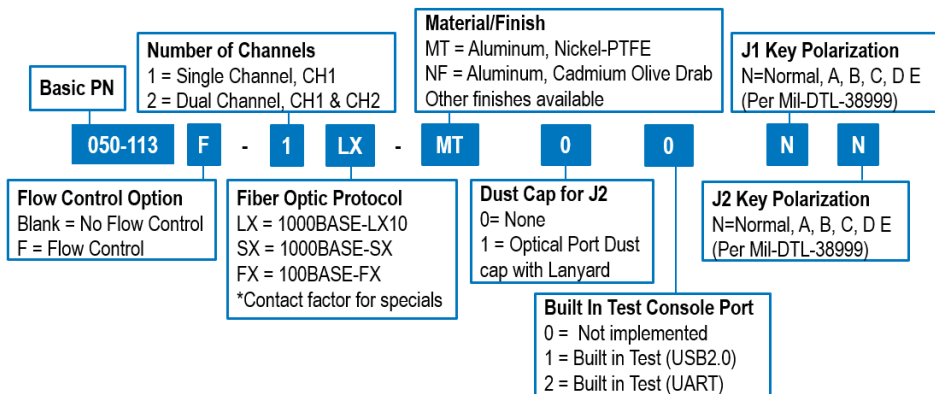

## 050-113 PRODUCT BRIEF

Media Converter, Single or Dual Channel, Panel Mount  
10/100/1000BASE-T to Fiber Optic Ethernet (SX, LX10 or FX)



### Functional Block Diagram

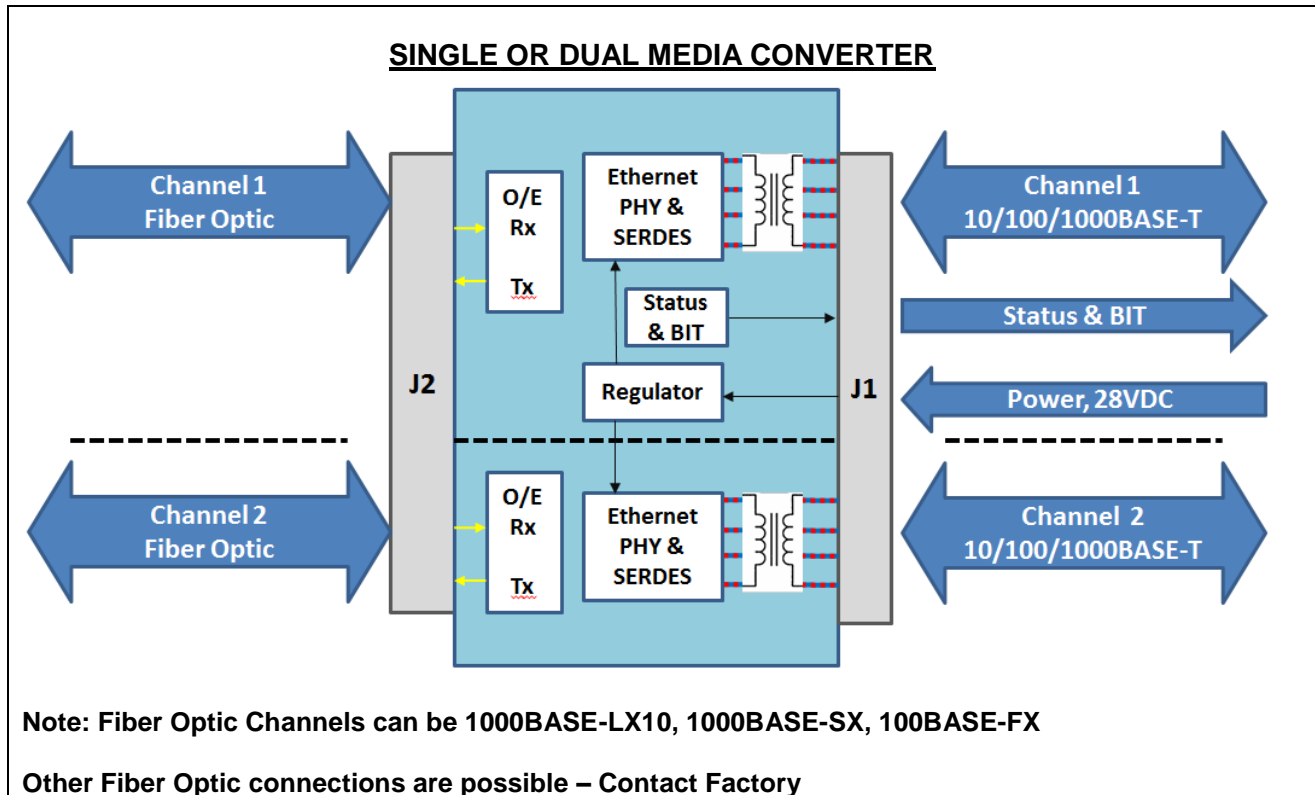

### Flow Control

Ethernet flow control is a mechanism for temporarily stopping the transmission of data on Ethernet computer networks. If data flow between the two devices connected to the media converter will vary in rate, it is up to the end user to ensure their higher speed devices are throttled correctly to ensure loss of data does not occur over time. Flow control can be enabled at the factory if so desired. Contact the factory for more details.

050-113 PRODUCT BRIEF

Media Converter, Single or Dual Channel, Panel Mount  
10/100/1000BASE-T to Fiber Optic Ethernet (SX, LX10 or FX)

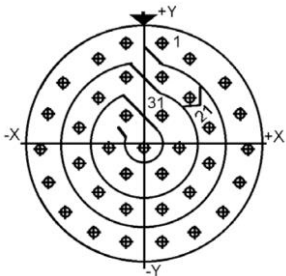
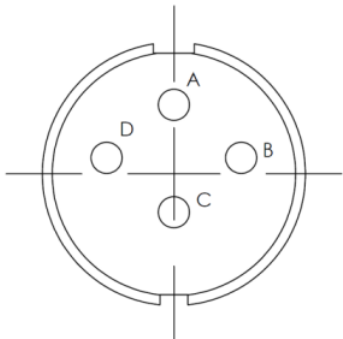

**Connectors**

NAME	Insert Arrangement	Function	Media Converter	Mating PLUG Connector
J1	 <p>D38999 Series III MIL-STD-1560 Arrangement 15-35</p>	Electrical Signal, Status and Built In Test (BIT), & Power	D38999 Series III type 15-35  <u>PIN CONTACTS, 22D</u>	Generic PN D38999/26#D35SN  Glenair PN 233-105-G6#15-35SN  <u>SOCKET CONTACTS, 22D</u>
J2	 <p>D38999 Series III MIL-STD-1560 Arrangement 13-4</p>	Fiber Optic Signal	D38999 Series III type, 13-4  <u>PIN CONTACTS</u>  LX10 CONFIGURATION:  SX or FX CONFIGURATION:	Generic PN D38999/26#C35SN  Glenair PN 180-091##06-13-4SN  <u>SOCKET CONTACTS</u>  LX10 CONFIGURATION Glenair PN 181-001-126S (M29504/5-4238)  SX CONFIGURATION Glenair PN 181-001-126 (M29504/54239)

Note: # = Environmental Class (Material/Finish)

## 050-113 PRODUCT BRIEF

Media Converter, Single or Dual Channel, Panel Mount  
10/100/1000BASE-T to Fiber Optic Ethernet (SX, LX10 or FX)



### ***Built In Test (BIT) Functionality - Optional Features***

This media converter can be offered with built in test functionality accessible through a Console Port via Universal Serial Bus 2.0 (USB 2.0) or via RS422 UART (TXD) or both options can be made available. Functional block diagram for this is shown below.

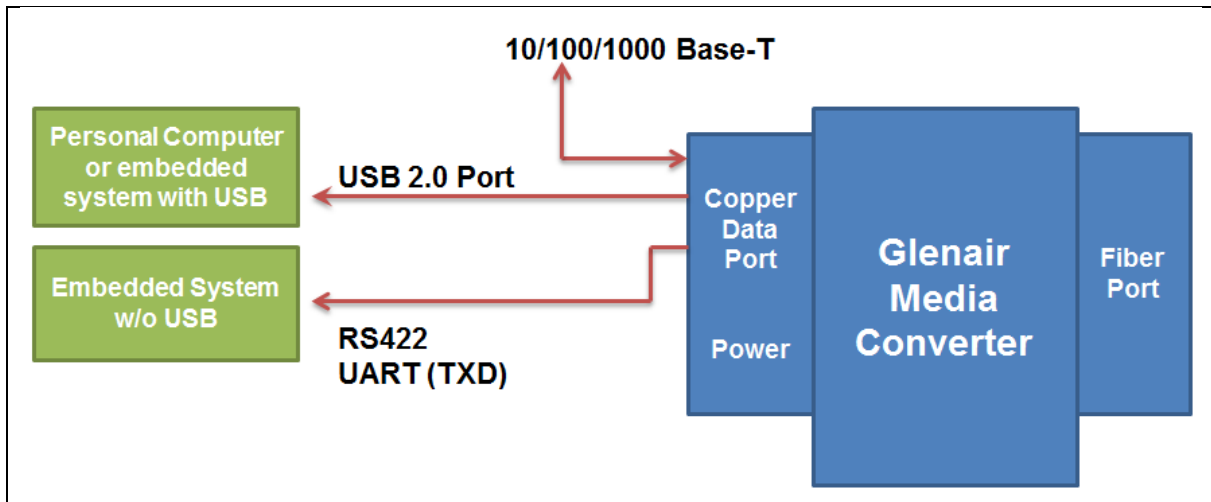

#### Universal Serial Bus (2.0) BIT

- Presents itself as a "Virtual" Communications Port
- Compatible with Microsoft Windows, Mac, and Linux OS's.
- On the computer side, open any terminal application (PuTTY, HyperTERM, TeraTERM, etc.) to communicate with the media converter hardware.
- Simple "Human Readable" status messages.

050-113 PRODUCT BRIEF

Media Converter, Single or Dual Channel, Panel Mount  
10/100/1000BASE-T to Fiber Optic Ethernet (SX, LX10 or FX)



TYPICAL USB CONSOLE WINDOW (PuTTY)

```
COM1 - PuTTY
*****
Glenair *
Media Converter Service Port *
*****
Unit Identification Information
*****
Product Code: 050-113-1SX
Unit Serial Number: 0145
Firmware Revision: 1.2.0
Product Description: 10/100/1000 Mbps Ethernet Copper to Fiber Media Converter

*****
Unit Status
*****
Temperature: 45 degrees C
Power Supply Status: Good
RX Loss of Signal, CH1: False
Transceiver Disable, CH1: False
Transceiver, TX Fault, CH1: False
Copper-Side Link Status, CH1: Up
Fiber-Side Link Status, CH1: Up
```



**Built In Test (BIT) Functionality – UART**

This media converter can be offered with built in test functionality accessible via an RS-422 Port. The UART Bit message is a 10 bit message with an update rate of 1 Hz. The message format can be seen below.

ALARM STATUS MESSAGES

- Fiber Link Status (Up or Down)
- Copper Link Status (Up or Down)

**Ethernet Media Converter Status Message Format**

Standard UART-Type Format (Start and Stop Bits, 8 Data bits, no parity)

Data Rate = 9600 baud, RS422 Output, Message Repetition Rate = 1 Sec

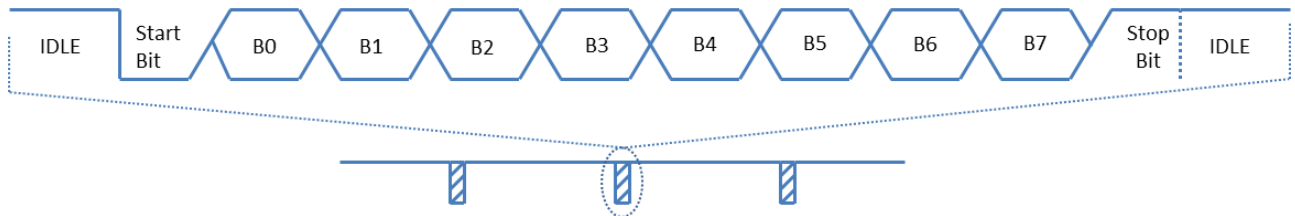

SERIAL STATUS MESSAGE BIT MAPPING

Bit	Description
0	Channel 1 Fiber Optic TX Fault (1 = Fault, 0 = No Fault)
1	Channel 1 Ethernet copper Link UP (1 = Link Up, 0 = Link Down)
2	Not used
3	Not used
4	Channel 2 Fiber Optic TX Fault (1 = Fault, 0 = No Fault)
5	Channel 2 Ethernet copper Link UP (1 = Link Up, 0 = Link Down)
6	Not used
7	Not used

**050-113 PRODUCT BRIEF**

Media Converter, Single or Dual Channel, Panel Mount  
 10/100/1000BASE-T to Fiber Optic Ethernet (SX, LX10 or FX)



## Ratings and Specifications – LX10 VERSION

### ABSOLUTE MAXIMUM RATINGS

Parameter	Symbol	Min	Typ	Max	Units	Notes
Storage Temperature	T <sub>s</sub>	-55		+100	°C	
Supply Voltage	V <sub>cc</sub>	-0.5		40	V	1 second maximum, 40V

### OPERATING CONDITIONS

Parameter	Symbol	Min	Typ	Max	Units	Notes
Operating Temperature	T <sub>op</sub>	-40		+85	°C	
Supply Voltage	V <sub>cc</sub>	18	28	36	V	
Supply Current	I <sub>cc</sub>		100	150	mA	@28VDC Per Channel

### OPTICAL CHARACTERISTICS – TRANSMITTER

Parameter	Symbol	Min	Typ	Max	Units	Notes
Optical Output Power	P <sub>OUT</sub>	-8.5	-4	-3	dBm	1310nm Fabry-Perot
Optical Wavelength	λ <sub>OUT</sub>	1285	1310	1345	nm	
Spectral Width	Δλ			3.5	nm	

### OPTICAL CHARACTERISTICS – RECEIVER

Parameter	Symbol	Min	Typ	Max	Units	Notes
Optical Sensitivity ( Input Power Range)	P <sub>IN,OP</sub>	-20		0	dBm	
Min. Sensitivity, BER 10 <sup>-12</sup> , PRBS 2 <sup>-7</sup> -1	P <sub>IN,MIN</sub>		-22	-20	dBm	PIN PD, LX10 source
Overload, BER 10 <sup>-12</sup> , PRBS 2 <sup>-7</sup> -1	P <sub>IN,MAX</sub>	0			dBm	
Optical Wavelength	λ <sub>IN</sub>	1100	1310	1590	nm	

### ETHERNET COMPLIANCE

Parameter	Medium Type	Distance	Notes
Gigabit Ethernet, IEEE 802.3ab, 1000BASE-T	TIA/EIA-568-B Cat 5E	100m	
Gigabit Ethernet, IEEE 802.3z, 1000BASE-LX10	Single Mode Fiber (9/125μm)	10km	



## 050-113 PRODUCT BRIEF

**Media Converter, Single or Dual Channel, Panel Mount  
10/100/1000BASE-T to Fiber Optic Ethernet (SX, LX10 or FX)**



### **Ratings and Specifications – SX VERSION**

#### **ABSOLUTE MAXIMUM RATINGS**

Parameter	Symbol	Min	Typ	Max	Units	Notes
Storage Temperature	T <sub>s</sub>	-55		+100	°C	
Supply Voltage	V <sub>cc</sub>	-0.5		40	V	1 second maximum, 40V

#### **OPERATING CONDITIONS**

Parameter	Symbol	Min	Typ	Max	Units	Notes
Operating Temperature	T <sub>op</sub>	-40		+85	°C	
Supply Voltage	V <sub>cc</sub>	18	28	36	V	
Supply Current	I <sub>cc</sub>		100	150	mA	@28VDC Per Channel

#### **OPTICAL CHARACTERISTICS – TRANSMITTER**

Parameter	Symbol	Min	Typ	Max	Units	Notes
Optical Output Power	P <sub>OUT</sub>	-9.5		-4	dBm	VCSEL, 62.5/125µm MM
Optical Wavelength	λ <sub>OUT</sub>	830	850	860	nm	
Spectral Width	Δλ			0.85	nm	

#### **OPTICAL CHARACTERISTICS - RECEIVER**

Parameter	Symbol	Min	Typ	Max	Units	Notes
Optical Sensitivity (Input Power Range)	P <sub>IN_OP</sub>	-17		-2	dBm	
Min. Sensitivity, BER 10 <sup>-12</sup> , PRBS 2 <sup>7</sup> -1	P <sub>IN_MIN</sub>		-22	-17	dBm	PIN PD
Overload, BER 10 <sup>-12</sup> , PRBS 2 <sup>7</sup> -1	P <sub>IN_MAX</sub>	-2	-1		dBm	
Optical Wavelength	λ <sub>IN</sub>	770	850	860	nm	

#### **ETHERNET COMPLIANCE**

Parameter	Medium Type	Distance	Notes
Gigabit Ethernet, IEEE 802.3ab, 1000BASE-T	TIA/EIA-568-B Cat 5E	100m	
Gigabit Ethernet, IEEE 802.3z, 1000BASE-SX	OM3 MMF (50/125µm) OM1 MMF (62.5/125µm)	550m 275m	850nm VCSEL

**050-113 PRODUCT BRIEF**

Media Converter, Single or Dual Channel, Panel Mount  
 10/100/1000BASE-T to Fiber Optic Ethernet (SX, LX10 or FX)



## Ratings and Specifications – FX VERSION

### ABSOLUTE MAXIMUM RATINGS

Parameter	Symbol	Min	Typ	Max	Units	Notes
Storage Temperature	T <sub>s</sub>	-55		+100	°C	
Supply Voltage	V <sub>cc</sub>	-0.5		40	V	1 second maximum, 40V

### OPERATING CONDITIONS

Parameter	Symbol	Min	Typ	Max	Units	Notes
Operating Temperature	T <sub>op</sub>	-40		+85	°C	
Supply Voltage	V <sub>cc</sub>	18	28	36	V	
Supply Current	I <sub>cc</sub>		100	150	mA	@28VDC, Per Channel

### OPTICAL CHARACTERISTICS – TRANSMITTER

Parameter	Symbol	Min	Typ	Max	Units	Notes
Optical Output Power	P <sub>OUT</sub>	-19		-14	dBm	1300nm LED (IEC 9314-3)
Optical Wavelength	λ <sub>OUT</sub>	1270	1310	1380	nm	
Spectral Width	Δλ		150		nm	

### OPTICAL CHARACTERISTICS - RECEIVER

Parameter	Symbol	Min	Typ	Max	Units	Notes
Sensitivity, BER 10 <sup>-10</sup> , PRBS 2 <sup>7</sup> -1	P <sub>IN</sub>			-32	dBm	PIN PD
Overload, BER 10 <sup>-10</sup> , PRBS 2 <sup>7</sup> -1	P <sub>IN</sub>	-14			dBm	
Optical Wavelength	λ <sub>IN</sub>	1270	1310	1380	nm	

### ETHERNET COMPLIANCE

Parameter	Medium Type	Distance	Notes
Fast Ethernet, IEEE 802.3u, 100BASE-T	TIA/EIA-568-B Cat 5E	100m	
Fast Ethernet, IEEE 802.3u, 100BASE-FX, IEC 9314-3	MMF (50/125μm) & (62.5/125μm)	2km	

**050-113 PRODUCT BRIEF**

**Media Converter, Single or Dual Channel, Panel Mount  
10/100/1000BASE-T to Fiber Optic Ethernet (SX, LX10 or FX)**



### ***Ratings and Specifications - (continued)***

#### **COMPLIANCE SPECIFICATIONS**

<b>CHARACTERISTIC</b>	<b>Standard</b>	<b>Condition</b>	<b>Notes</b>
Mechanical Shock	MIL-STD-810	40g	6-9rms
Mechanical Vibration	MIL-STD-810	30g rms	
ESD	MIL-STD-883	Class II	2200V HBM
Conducted Emissions, Power Leads, 30 Hz to 10 kHz	MIL-STD-461F	CE101	
Conducted Emissions, Power Leads, 10 kHz to 10 MHz	MIL-STD-461F	CE102	
Conducted Susceptibility, Power Leads, 30 Hz to 150KHz	MIL-STD-461F	CS101	
Conducted Susceptibility, Transients, Power Leads	MIL-STD-461F	CS106	
Conducted Susceptibility, Structure Current, 60 Hz to 100 kHz	MIL-STD-461F	CS109	
Conducted Susceptibility, Bulk Cable Injection, 10 kHz to 200 MHz	MIL-STD-461F	CS114	
Radiated Susceptibility, Magnetic Field, 30 Hz to 100 kHz	MIL-STD-461F	RS101	
Radiated Susceptibility, Electric Field, 2 MHz to 18 GHz	MIL-STD-461F	RS103	
Radiated Emissions, Magnetic Field, 30 Hz to 100 kHz	MIL-STD-461F	RE101	
Radiated Emissions, Electric Field, 10 kHz to 18 GHz	MIL-STD-461F	RE102	
Mating Durability	MIL-DTL-38999/20	500 Cycles	
Flame Resistance	EIA364-104		30 seconds
Damp Heat	EIA364-321		240 hours
Eye Safety	CDRH and IEC-825	Class 1 Laser Product	

**050-113 PRODUCT BRIEF**

**Media Converter, Single or Dual Channel, Panel Mount  
10/100/1000BASE-T to Fiber Optic Ethernet (SX, LX10 or FX)**



## ***Ratings and Specifications - (continued)***

### **Material/Finish**

<b>Item</b>	<b>Material/Finish</b>
Housing & Connector Shell	Aluminum
Plating Finish: M	Nickel
Plating Finish: MT	Nickel PTFE
Plating Finish: NF	Olive Drab Cadmium
Contacts	Copper alloy, 50 µInch gold plated
D38999 Inserts	Thermoplastics
Interfacial Seals, 38999 only	Elastomer, Fluorosilicon
Optical Ferrules & Sleeves	Zirconia, Ceramic
Insulators	Liquid crystal polymer (LCP)
Contact retention clip	Beryllium copper alloy
Seal, O-rings	Fluorosilicone rubber
Seal	Silicone elastomer
Spring	Nickel-plated beryllium copper
PC tail contacts	Copper alloy/gold plated
PCB flex	FR4 & Polyimide
Encapsulant	HYSOL EE4215
Solder type: Connector PC Tails to PCBA	Sn63Pb37
Solder type: PCBA component attach	RoHS compliant Sn95/Sb5 (232°C melting temp) & RoHS compliant Sn96.5/Ag3.0/Cu0.5 (217° melting)

## 050-113 PRODUCT BRIEF

Media Converter, Single or Dual Channel, Panel Mount  
10/100/1000BASE-T to Fiber Optic Ethernet (SX, LX10 or FX)



### OUTLINE DRAWING & PANEL CUT OUT

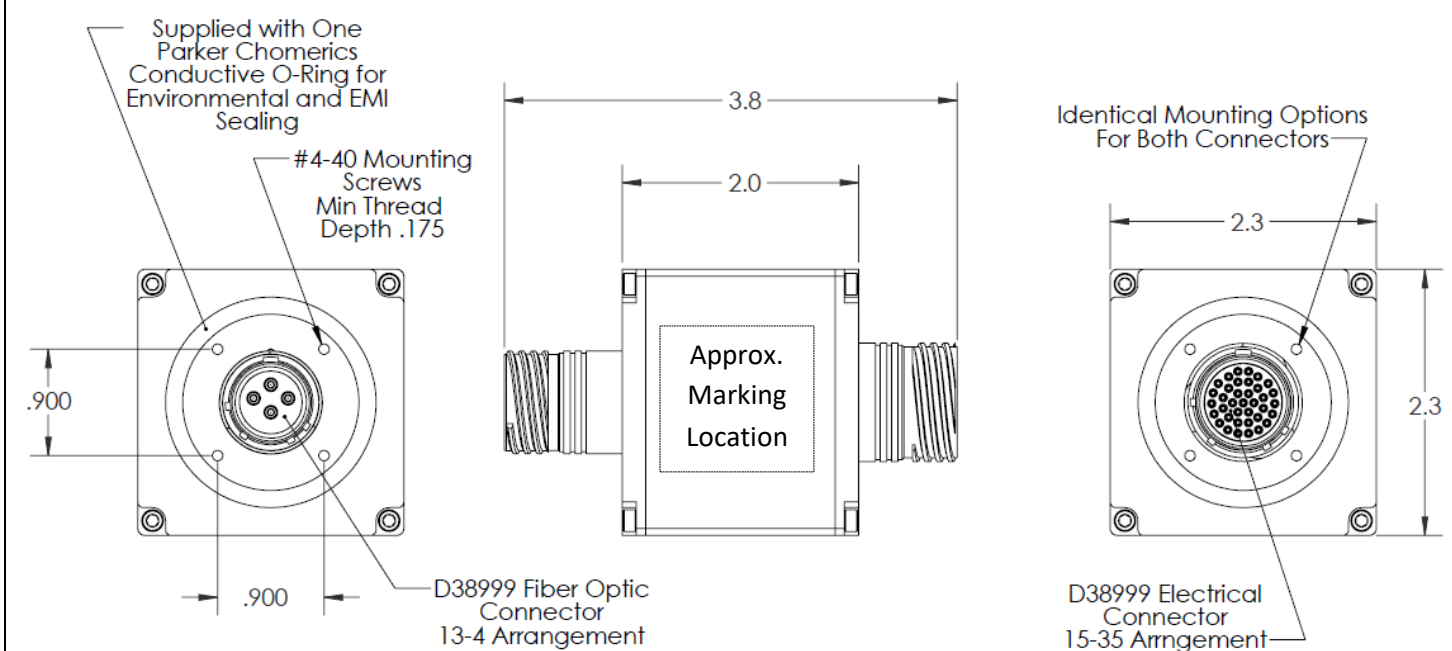

#### Dimensional Tolerances Unless specified otherwise:

$0.x \pm 0.1$   
 $0.xx \pm 0.03$   
 $0.xxx \pm 0.005$

#### Marking:

Assembly is identified with Manufacturer's Name, Cage Code, Part Number, Date Code and Serial Number in approximate location shown

Connectors will be covered with protective caps at time of shipment

Please contact Glenair for other configurations

#### PANEL CUT OUT - J1 or J2

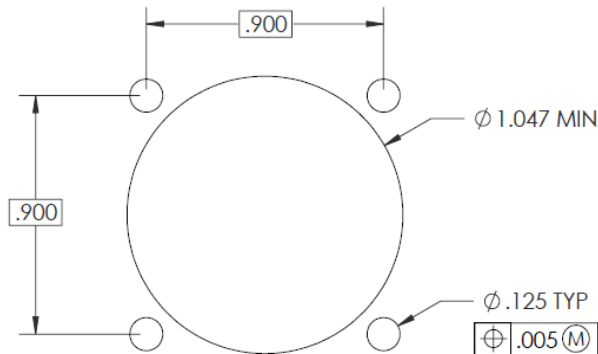

## X-ON Electronics

Largest Supplier of Electrical and Electronic Components

*Click to view similar products for [Media Converters](#) category:*

*Click to view products by [Glenair](#) manufacturer:*

Other Similar products are found below :

[EIS-PS-US](#) [CF-020010-009](#) [EIS-EXTEND-C-EU](#) [DT5002F](#) [WT32-ETH01](#) [USR-K6](#) [WC-PD13F012A](#) [WC-PD30B050G](#) [CF-020011-2N9](#)  
[EKI-1751-AE](#) [EKI-1751PI-M-AE](#) [EKI-1751PI-R-AE](#) [EKI-2541M-AE](#) [EKI-2541MI-AE](#) [EKI-2541S-AE](#) [EKI-2541SI-AE](#) [EKI-2741FI-BE](#)  
[EKI-2741FL-EU-AE](#) [EKI-2741FL-US-AE](#) [EKI-2741LX-AE](#) [CA-628485-D84](#) [CA-628485-D85](#) [CF-020008-000](#) [CF-020008-001](#) [CF-020010-721](#) [CF-020010-97X](#) [CF-020011-1N9](#) [CF-020011-32N](#) [CF-020011-330](#) [CF-901201-097](#) [CTC-55F005-NW](#) [102MCE-SC-15](#) [102MC-SC](#)  
[850-15526](#) [855-10932](#) [856-15410](#) [857-11912](#) [IMC-350I-MMST-PS-A](#) [IMC-350I-SE-PS-A](#) [IMC-350-MMST-PS-A](#) [IMC-350I-M8ST-PS-A](#)  
[IMC-350I-MM-A](#) [IMC-350I-SE-A](#) [IMC-350I-M8-A](#) [IMC-370-MM-PS-A](#) [IMC-370I-MM-A](#) [IMC-370I-SST-PS-A](#) [CTM1051KAT](#)  
[CTM8251KAT](#) [MS8PD](#)