



Micro-D to AlphaLink flex jumper

Micro-D to AlphaLink Flex Jumpers

High-reliability Micro-D MIL-DTL-83513 type rectangular connectors in 7 contact arrangements, terminated with rugged polyimide-based flex to high-performance AlphaLink SL board level connectors.

Recommended Micro-D I/O to AlphaLink Contact Arrangements*

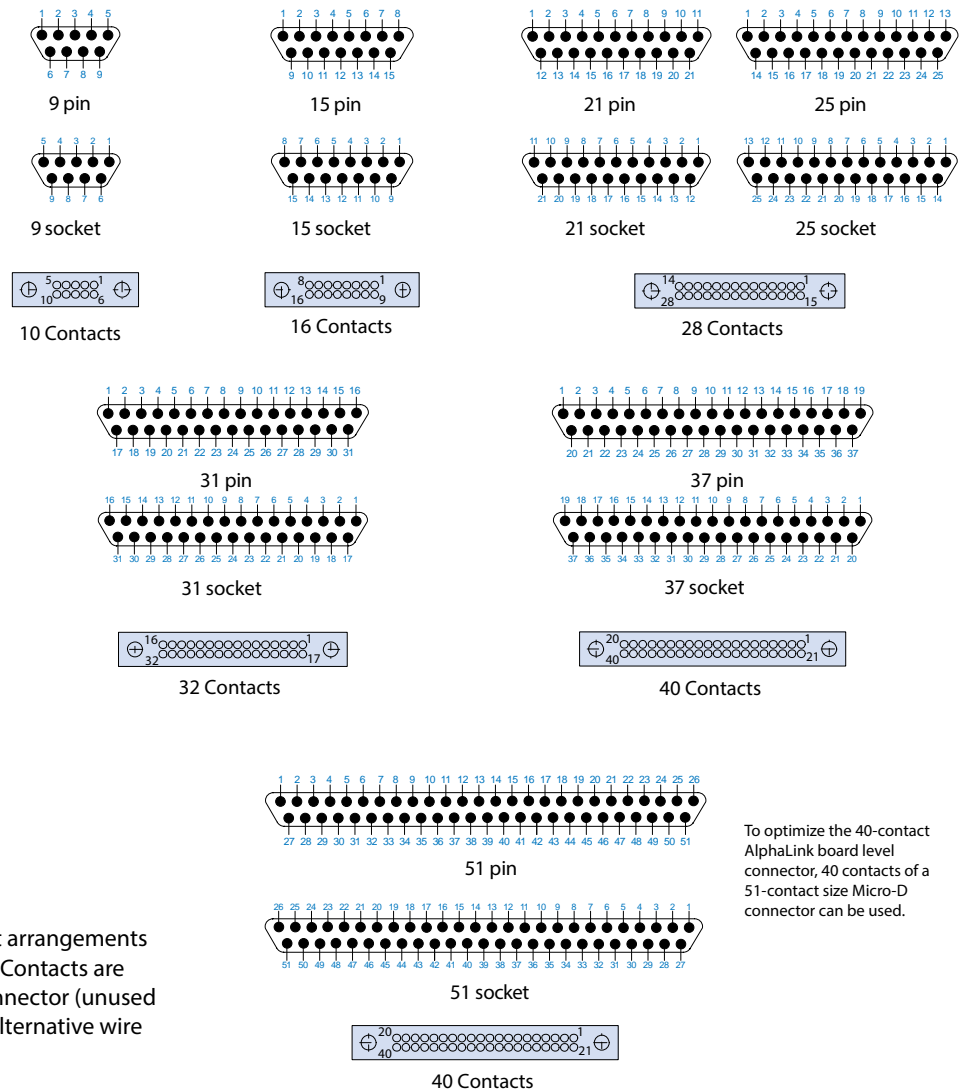

To optimize the 40-contact AlphaLink board level connector, 40 contacts of a 51-contact size Micro-D connector can be used.

* These are recommended contact arrangements only, but do offer best availability. Contacts are mapped 1-to-1 from I/O to B/L connector (unused B/L contacts not connected). For alternative wire schedules, please consult factory.

Table I - Shell Material/Finish	
Sym	Description
1	Aluminum Alloy-Cadmium
2	Aluminum Alloy-Electroless Nickel
3	Stainless Steel-Pasivated
5	Aluminum Alloy-Gold
33	Aluminum Alloy-Ni/Pfte

Table III- I/O Hardware Options	
Sym	Description (Rear Panel Mount)
R1	Jackpost for .032 Thick Panel
R2	Jackpost for .047 Thick Panel
R3	Jackpost for .062 Thick Panel
R4	Jackpost for .093 Thick Panel
R5	Jackpost for .125 Thick Panel
R6	Jackpost for .080 Thick Panel

Table II (I/O Connector Dimensions)							
Shell Size	A ±.005	B ±.003	C Max	D Max	E±.003	F±.005	G±.005
9P	.960 (24.4)	.565 (14.4)	.334 (8.5)	.184 (4.7)	.183 (4.6)	.529 (13.4)	.775 (19.7)
9S	.960 (24.4)	.565 (14.4)	.400 (10.2)	.250 (6.4)	.195 (5.0)	.541 (13.7)	.775 (19.7)
15P	1.110 (28.2)	.715 (18.2)	.484 (12.3)	.184 (4.7)	.183 (4.6)	.529 (13.4)	.925 (23.5)
15S	1.110 (28.2)	.715 (18.2)	.550 (14.0)	.250 (6.4)	.195 (5.0)	.541 (13.7)	.925 (23.5)
21P	1.260 (32.0)	.865 (22.0)	.634 (16.1)	.184 (4.7)	.183 (4.6)	.529 (13.4)	1.075 (27.3)
21S	1.260 (32.0)	.865 (22.0)	.700 (17.8)	.250 (6.4)	.195 (5.0)	.541 (13.7)	1.075 (27.3)
25P	1.360 (34.5)	.965 (24.5)	.734 (18.6)	.184 (4.7)	.183 (4.6)	.529 (13.4)	1.175 (29.8)
25S	1.360 (34.5)	.965 (24.5)	.800 (20.3)	.250 (6.4)	.195 (5.0)	.541 (13.7)	1.175 (29.8)
31P	1.510 (38.4)	1.115 (28.3)	.884 (22.5)	.184 (4.7)	.183 (4.6)	.529 (13.4)	1.325 (33.7)
31S	1.510 (38.4)	1.115 (28.3)	.950 (24.1)	.250 (6.4)	.195 (5.0)	.541 (13.7)	1.325 (33.7)
37P	1.660 (42.2)	1.265 (32.1)	1.034 (26.3)	.184 (4.7)	.183 (4.6)	.529 (13.4)	1.473 (37.4)
37S	1.660 (42.2)	1.265 (32.1)	1.100 (27.9)	.250 (6.4)	.195 (5.0)	.541 (13.7)	1.473 (37.4)
51P	2.035 (51.7)	1.615 (41.0)	1.384 (35.2)	.228 (5.8)	.183 (4.6)	.529 (13.4)	1.990 (50.5)
51S	2.035 (51.7)	1.615 (41.0)	1.450 (36.8)	.296 (7.5)	.195 (5.0)	.541 (13.7)	1.990 (50.5)

* Contacts mapped 1-to-1 from I/O to B/L connector (unused B/L contacts not connected). For alternative wire schedules, please consult factory.

Table IV - B/L Connector Dimensions		
Layout	AA	BB
4	.527 (13.4)	.350 (8.9)
8	.627 (15.9)	.450 (11.4)
10	.677 (17.2)	.500 (12.7)
16	.827 (21.0)	.650 (16.5)
20	.927 (23.5)	.750 (19.1)
28	1.127 (28.6)	.950 (24.1)
32	1.227 (31.2)	1.050 (26.7)
40	1.427 (36.2)	1.250 (31.8)

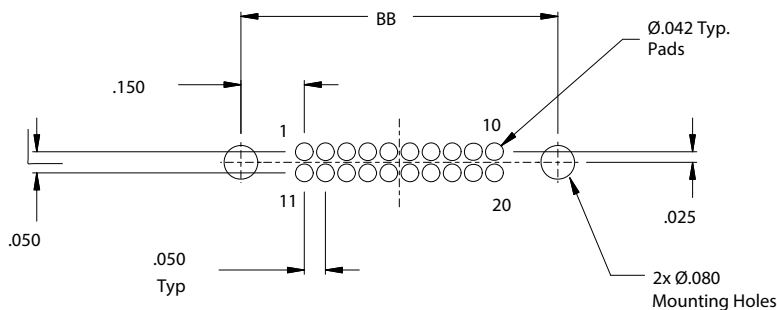

Recommended PCB Layout
(See Table IV)



Rear panel mount environmental Micro-D connector to AlphaLink® SL flex jumper



1770-2449

GRPM PANEL-MOUNT MICRO-D INPUT/OUTPUT (I/O) CONNECTOR TO ALPHALINK® SL SPRING LOADED CONTACT BOARD LEVEL (B/L) CONNECTOR

How To Order 1770-2449											
Sample Part Number	1770-2449	-2	-15	S	R1	-16	2	T	-6	S	
Series / Basic Part No.	GRPM Panel-Mount Micro-D I/O connector to Series 171 AlphaLink® SL										
I/O Material / Finish	See Table I										
I/O Connector Shell Size	-9, -15, -21, -25, -31, -37, -51 (See Table II)										
I/O Contact Style	P = Pin/Plug S = Socket/Receptacle										
I/O Hardware Option	R1 = Jackpost for .032 Thick Panel R2 = Jackpost for .047 Thick Panel R3 = Jackpost for .062 Thick Panel R4 = Jackpost for .093 Thick Panel R5 = Jackpost for .125 Thick Panel R6 = Jackpost for .080 Thick Panel										
AlphaLink® Shell size	-4, -8, -10, -16, -20, -28, -32, -40 (See Table IV)										
AlphaLink® Finish	2 = Nickel 5 = Gold										
AlphaLink® Hardware Option	T = Threaded thru hole Omit for thru hole										
Assembly Length	3 = 3.00 ± .05 inches 6 = 6.00 ± .05 inches 12 = 12.00 ± .05 inches										
Optional Shielding	S = With shielding Omit for none										

Sym	Description
1	Aluminum Alloy-Cadmium
2	Aluminum Alloy-Electroless Nickel
3	Stainless Steel-Pasivated
5	Aluminum Alloy-Gold
33	Aluminum Alloy-Ni/Pfte

MATERIALS AND FINISHES

B/L connector shell: Aluminum alloy. I/O shell: See Table I
 Insulator: High-grade rigid dielectric
 Socket interfacial seal: Fluorosilicone
 Contacts: Copper Alloy/Gold Plated
 Potting: Epoxy
 Hardware: Stainless steel/passivated

NOTES

Input/Output Micro-D rectangular environmental connector:
 I/O connector designed to meet the performance requirements of MIL-DTL-83513 (MWDM series)
 I/O interface dimensions IAW MIL-DTL-83513
 Unused cavities in I/O connector to be populated with contacts IAW MIL-DTL-83513
 Contacts mapped 1-to-1 from I/O to B/L connector (unused B/L contacts not connected). For alternative wire schedules, please consult factory.

Board Level AlphaLink® SL connector:

B/L AlphaLink® SL connectors are built in accordance with Glenair drawing 171-134-02
 B/L connectors are paired with I/O connectors as shown in Contact Arrangements diagram, page 32

Flex Performance:

Shielding - EMI shielding film.
 Bend radius is 6 to 10 times the flex thickness.
 Typical flex will be .01 ± .005 thick, rugged, potted, polyimide-based flex.
 Flex cables are terminated from the I/O connector to the B/L connector on a 1 to 1 connection (unused B/L contacts are not connected)
 Workmanship shall be IAW IPC-6013, Class 2.

Consult factory for more options and/or special designs and requirements

Rear panel mount environmental Micro-D connector to AlphaLink SL flex jumper

1770-2449

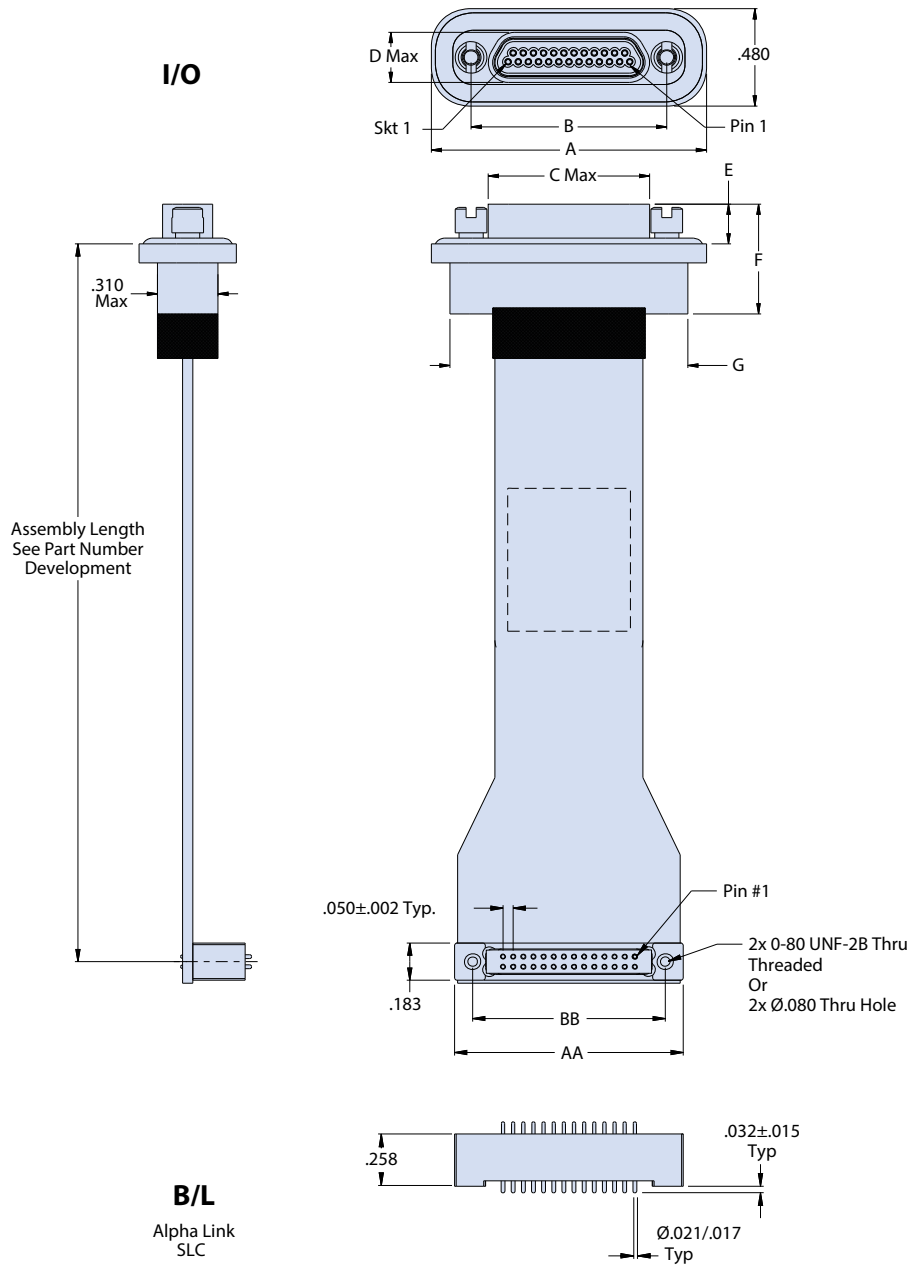

X-ON Electronics

Largest Supplier of Electrical and Electronic Components

Click to view similar products for [glenair](#) manufacturer:

Other Similar products are found below :

[GMR7580-15P4BSU](#) [DC40-10L](#) [MWDM2R-9P-4K5-18H-464A](#) [MWDM2R-25P-6K5-58M-464A](#) [805-001-16NF11-4SA](#) [687-348Z4-8-6](#)
[557-107M3-05CB](#) [450DS001N10-325](#) [MR75909P1BSU](#) [809-166-NF8](#) [103-026-012](#) [891-001-25PS-0A7-18J](#) [5M2920-3CW](#) [6000-063-0022](#)
[M28840/17AC1G3](#) [M28840/29CB1DAP1](#) [M32139/03-B06ST](#) [M39029/88-488](#) [M8351303-B14N](#) [M83513/03-C16N](#) [M83513/03-F11N](#)
[M83513/04-E03N](#) [M83513/13-B03CW](#) [M8351329-G02NW](#) [M85049130-07M](#) [M85049/1911N02](#) [M8504924-5W](#) [M85049/3610W03](#)
[M85049/39-17W](#) [M8504956-24N](#) [M85049/74-10-1](#) [M8504988-17P03](#) [M8504988-21N03](#) [M8504992-11M](#) [D38999/23YE26SN](#)
[759EA458NF32Z1732-40-102.9](#) [801-008-26NF7-25SA](#) [801-025-ARB2M6-4NA-12](#) [805-002-16M12-5SA](#) [858-003-01F](#) [860-004R-](#)
[B7MT07A-30-20](#) [G65217](#) [G8187C2010-44N](#) [G8377-21B](#) [G8801-09N](#) [G8801-25N](#) [G8859-174FNF](#) [947-432ME21-11SN](#) [947-432ME21-](#)
[35PN](#) [D3899933F21R](#)