



290-011 and 290-012 Stainless Steel Molding Adapters

To select the appropriate molding adapter, consider the following basic suggestions to ensure a high integrity, quality molded termination:

- Select a molding adapter which will provide adequate inside working room to accept the termination envelope, especially if there are shield terminations, splices, etc.
- If the termination is to be molded with neoprene or other material using a transfer molding process, select the molding adapter cable entry diameter close to the outside diameter of the cable or termination envelope.

Prior to use, lubricate O-rings with high grade silicone lubricant (Molykote M55 or equivalent).

Metric dimensions (mm) are indicated in parentheses.

FIXED ENTRY

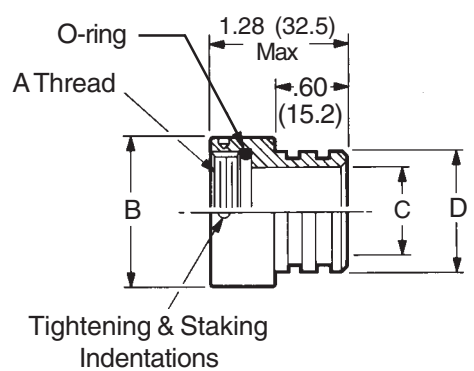

Basic Part No. 290WS011-18
Shell Size (Table I) _____

VARIABLE ENTRY

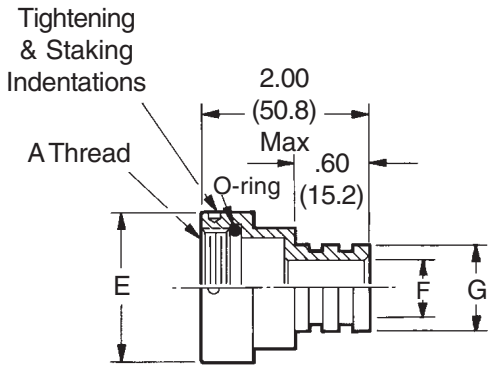

Basic Part No. 290WS012-18 12
Shell Size (Table II) _____
Entry Size (Table III) _____

SHELL SIZE	A THREAD CLASS 2B	B DIA MAX	C DIA	D DIA
10	5/8 - 24 UNEF	.855 (21.7)	.430 (10.9)	.670 (17.0)
12	3/4 - 20 UNEF	.965 (24.5)	.535 (13.6)	.780 (19.8)
14	7/8 - 20 UNEF	1.090 (27.7)	.660 (16.8)	.905 (23.0)
16	1 - 20 UNEF	1.220 (31.0)	.785 (19.9)	1.020 (25.9)
18	1 1/8 - 16 UN	1.370 (34.8)	.880 (22.4)	1.135 (28.8)
20	1 1/4 - 16 UN	1.525 (38.7)	1.005 (25.5)	1.250 (31.8)
22	1 3/8 - 16 UN	1.655 (42.0)	1.130 (28.7)	1.383 (35.1)
24	1 1/2 - 16 UN	1.775 (45.1)	1.255 (31.9)	1.510 (38.4)

SHELL SIZE	PISTON O-RING
10	2-014
12	2-016
14	2-018
16	2-020
18	2-022
20	2-024
22	2-026
24	2-028

* Parker o-ring part numbers. Compound N674-70 or equivalent.

SHELL SIZE	A THREAD CLASS 2B	E DIA MAX	MAX ENTRY
10	5/8 - 24 UNEF	.855 (21.7)	
12	3/4 - 20 UNEF	.965 (24.5)	12
14	7/8 - 20 UNEF	1.090 (27.7)	
16	1 - 20 UNEF	1.220 (31.0)	16
18	1 1/8 - 16 UN	1.370 (34.8)	
20	1 1/4 - 16 UN	1.525 (38.7)	20
22	1 3/8 - 16 UN	1.655 (42.0)	
24	1 1/2 - 16 UN	1.775 (45.1)	24

ENTRY NO.	F DIA	G DIA
10	.430 (10.9)	.670 (17.0)
12	.535 (13.6)	.780 (19.8)
14	.660 (16.8)	.905 (23.0)
16	.785 (19.9)	1.020 (25.9)
18	.880 (22.4)	1.135 (28.8)
20	1.005 (25.5)	1.250 (31.8)
22	1.130 (28.7)	1.383 (35.1)
24	1.255 (31.9)	1.510 (38.4)

ENTRY NO.	TORQUE ± 5 IN. LBS.
10	80
12	100
14	120
16	120
18	140
20	140
22	140
24	150

X-ON Electronics

Largest Supplier of Electrical and Electronic Components

Click to view similar products for [Circular MIL Spec Strain Reliefs & Adapters](#) category:

Click to view products by [Glenair](#) manufacturer:

Other Similar products are found below :

[896227-000](#) [899170S004](#) [0113-023-000](#) [6000-063-0022](#) [CS6624-000](#) [620AB038Z136](#) [620AS001Z108](#) [620AS038Z112](#) [620AS038Z120](#)
[620AS038Z132](#) [620FB038NF08](#) [620HA038NF09](#) [620HA038NF11](#) [620HA038NF13](#) [620HA038NF25](#) [620HB049NF17](#) [620HS038NF11](#)
[620HS038Z121](#) [620HS042XM19](#) [620HS042XM25](#) [620HS048B17](#) [620MS064NF12](#) [620MS065Z107](#) [620MS065ZNU06](#) [627-123NF21-11](#)
[627-125NF23-6](#) [630J041M06H](#) [630J041M20H](#) [637S010NF0212H](#) [637S010NF0416A](#) [640830-000](#) [659943-000](#) [66241-10A](#) [CW0597-000](#)
[CW0598-000](#) [CW0948-000](#) [CY0122-000](#) [M85049/41-6A W/B](#) [M85049/42-12DS](#) [M85049/47N8](#) [M85049/51-1-14S](#) [M85049/51S16S](#)
[M85049/60-1N16](#) [M85049/60-2G12W](#) [M85049/69-11N](#) [CZ3661-000](#) [D02922-000](#) [70.360.1628.0](#) [703797-000](#) [705825-000](#)