

ALUMINUM TOOL FOR USE WITH GLENAIR COMPOSITE BACKSHELLS

600 - 091 - 16

Product Series	Basic Number	Dash Number for Individual Wrench or:
		<i>K</i> - Kit of dash numbers 08 thru 28
		<i>KC</i> - "K" kit with case
		<i>KL</i> - Kit of dash number 32 thru 44
		<i>KLC</i> - "KL" kit with case
		<i>KIT</i> - Kit of dash numbers 08 thru 44 with case

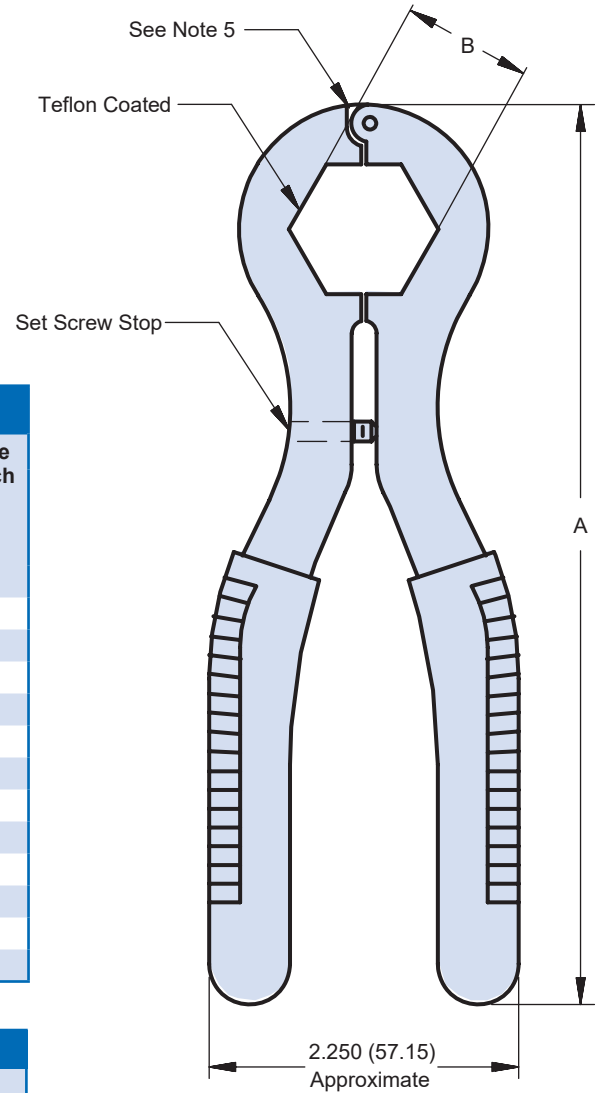
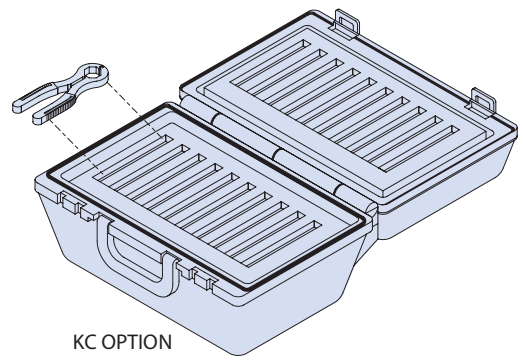

TABLE I: DASH NUMBER					
Dash Number	A Ref	B Hex ² Ref	Connector for Shell Size		Composite Torque Inch Pounds In-Lbs Min/Max
			Codes A & F	Code H	
08	7.56 (192.0)	.750 (19.1)	08	09	20/25
10	7.56 (192.0)	.875 (22.2)	10	11	20/30
12	7.56 (192.0)	1.000 (25.4)	12	13	25/35
14	7.56 (192.0)	1.125 (28.6)	14	15	25/35
16	7.56 (192.0)	1.250 (31.8)	16	17	30/40
18	7.56 (192.0)	1.375 (34.9)	18	19	30/40
20	8.50 (215.9)	1.500 (38.1)	20	21	35/45
22	8.50 (215.9)	1.625 (41.3)	22	23	35/45
24	8.50 (215.9)	1.750 (44.5)	24	25	35/45
28	9.50 (241.3)	2.000 (50.8)	28		115/125
32	10.00 (254.0)	2.250 (57.2)	32		115/125
36	10.00 (254.0)	2.500 (63.5)	36		112/125
44	10.00 (254.0)	3.000 (76.2)	44		N/A

- ### APPLICATION NOTES
1. Use in conjunction with Glenair 600G161 torque wrench and 600-162B or 600-162BV bench mounts (see page 14).
 2. Adjust set screw per tool setting procedure GAP134 (available on Glenair.com). Once adjusted must fit Glenair hex composite coupling nuts
 3. Customer is responsible for maintaining adjustment to compensate for wear.
 4. Replace tool if excessive wear is observed
 5. Gap is permissible during tool use for coupling nut assembly
 6. If set screw becomes loose causing loss of adjustment reapply suitable thread locking compound
 7. Wrenches are made of aluminum alloy with vinyl grips.
 8. Using other manufacturer's hex wrench pliers or soft jaw coated pliers will result in premature fracturing or damage to the composite product



KC OPTION
Approximate Case Dimensions: 13.5 x 15.5 x 3.875

X-ON Electronics

Largest Supplier of Electrical and Electronic Components

Click to view similar products for [Circular MIL Spec Tools, Hardware & Accessories](#) *category:*

Click to view products by [Glenair](#) *manufacturer:*

Other Similar products are found below :

[0113-201-2025](#) [600-079-06](#) [600-146-06](#) [M10-101983-183](#) [M10-454396-008](#) [602GB18808](#) [CS3102A-22-14PW](#) [M2887615-CD](#) [627-009](#)
[M38999/9-19B](#) [630A007NF083A](#) [630B007M051A](#) [630BJ003NF032H](#) [637-149NF04B](#) [M39029/29-215](#) [6408-203V-09273](#) [6426-201-11343](#)
[650FS002NF16](#) [660-008NF14S7-01](#) [660-009M22H8-03](#) [660-013NF19U6-210](#) [660-015M10S6-17](#) [660-015NF10S5-01](#) [660-015NF14R3.5-01](#)
[660-023NF19H6-19](#) [660-024NF11S12-01](#) [660-024NF11S3-01](#) [660-024NF17S4-109](#) [660-050XM17F4-01](#) [660-068NF25R6-30G](#) [660-](#)
[070M23S8-04](#) [660-073MTCH9-20](#) [M83723/61-18W](#) [M83723/61-218R](#) [M83723/61-224W](#) [667-084-23C](#) [667-084-35C](#) [667-224NF16](#) [687-](#)
[697NF-1](#) [M85049/94-10-A](#) [M85049/96-7-A](#) [M855282-10A01A](#) [M85528/2-10B](#) [M855282-18A01A](#) [M85528/2-22A01A](#) [M85528/2-22AA](#)
[710HS460NF2508](#) [780-001-22G12-SK](#) [780-002-19G12-SK](#) [780-002-20G12SK](#)