



## GSK-118 80 Second Voice Recorder w/ 5 watt Amplifier

### INTRODUCTION

This pre-assembled circuit is a very adaptable digital audio recorder that comes with a built in amplifier. It can select between an internal MIC or an external source for recording. This circuit can also be connected to a PIR or other external sensor to create an automated response for specific situations.

### CIRCUIT DESCRIPTION

Match the components to the following locations on the PCB

- $\pm 5V$  for power supply
- SP1 and SP2 for speaker
- SW1 switch for playing/pausing messages
- SW2 switch for selecting play/rec mode
- J1 for jumper – if connected, circuit will run continuously. If not connected, circuit works through switch SW1 or receives external signal
- I/P SENSOR for PIR, Coin acceptor, or other switches/sensors
- LINE IN for external sound connection
- JM1 and JM2 for jumpers to select the source sound when recording. When connected to MIC, it records the microphone. When connected to IN, it records the LINE IN.
- SMP for adjusting the quality of the recording. Clockwise adjustment reduces the quality but lengthens max time of possible recording. Counter clockwise adjustment increases quality but reduces recording length.
- VOL for adjusting the sound level of playback. Clockwise to increase volume and counter clockwise to decrease the volume.

### USING THE RECORDER AND PLAYBACK FUNCTIONS

#### How to select the sound recorder

1. To record sound through the built in MIC, connect JM1 and JM2 at the MIC side.
2. To record sound from an external source, connect external signal wire to LINE IN and connect JM1 and JM2 to IN side.

#### How to record and playback

1. Remove J1 and select the recording source as mentioned above. Slide switch SW2 to REC position.
2. Press SW1 to start recording. When recording, LED2 will light up.
3. Press SW1 again to stop recording at anytime. When finished, LED2 will turn off.
4. Slide SW2 to PLAY position.
5. Press SW1 to listen to the sound. Press SW1 again anytime to stop playback.

## GENERAL TROUBLESHOOTING

1. Start by turning the unit off for about 10 seconds. This will reset the IC. Power it back on and see if the issue remains.
2. Please note the size of the speaker used – it must not exceed 50 W at 8 ohms.
3. If the volume is too high, the speaker will only beep.

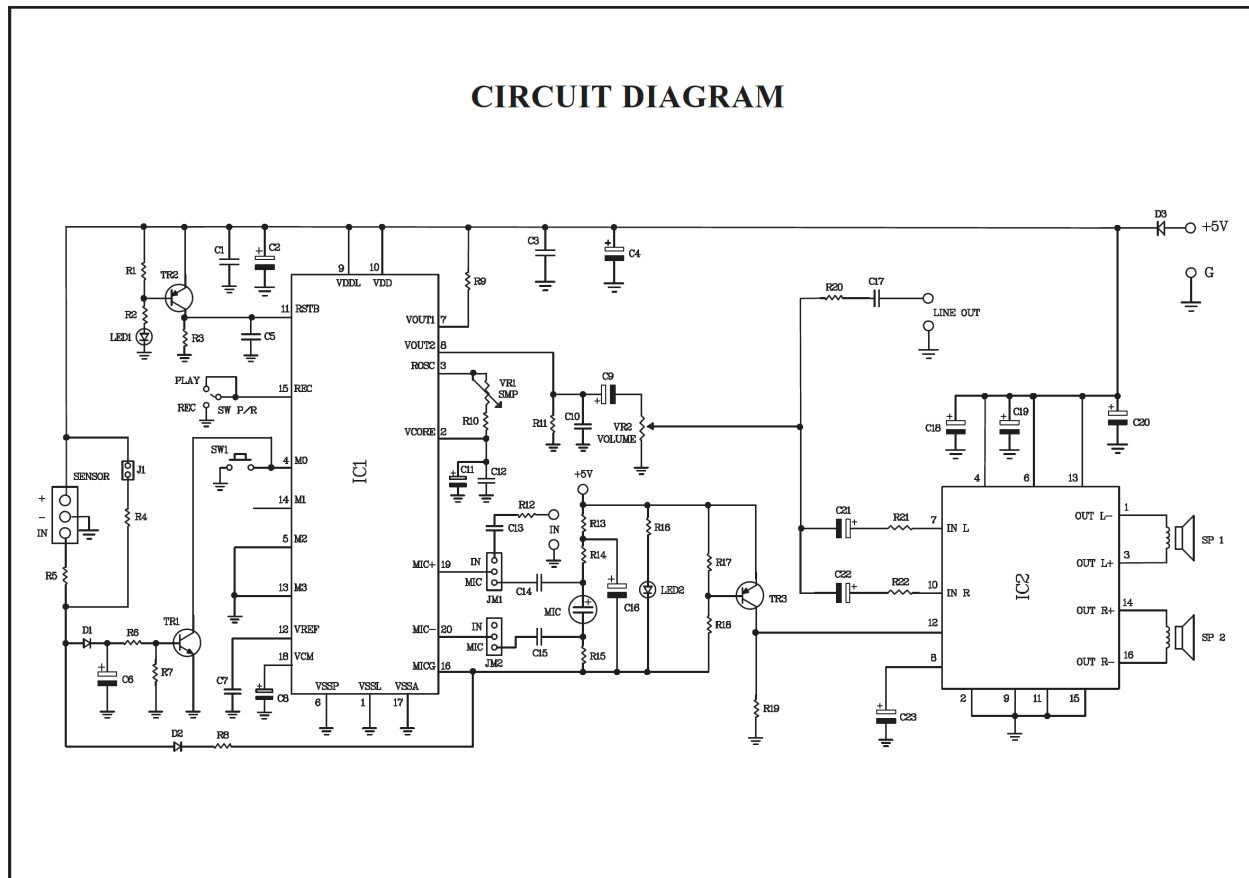

# INSTALLATION OF THE 80 SECOND VOICE RECORDER WITH 5 WATT AMPLIFIER CIRCUIT

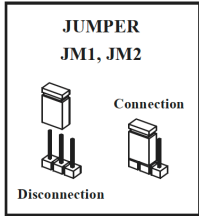
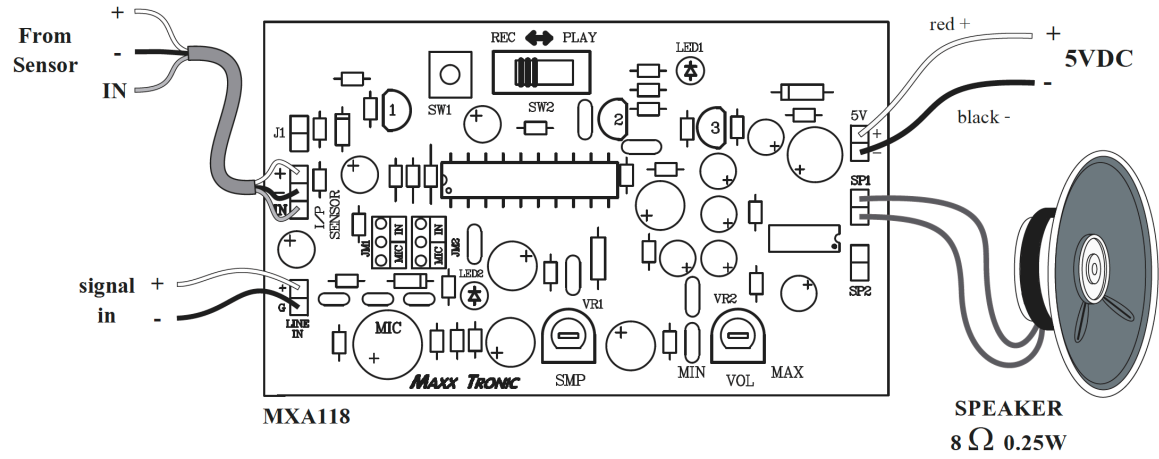

NO.1

## X-ON Electronics

Largest Supplier of Electrical and Electronic Components

*Click to view similar products for [Audio IC Development Tools](#) category:*

*Click to view products by [Global Specialties](#) manufacturer:*

Other Similar products are found below :

[1580/5171-DEMO](#) [LM4935RLEVAL](#) [LM4923LQBD](#) [MAX9738EVKIT+](#) [EVAL-ADAV803EBZ](#) [CDBWM8725-M-1](#) [CDBWM8533-M-1](#)  
[EV\\_ICS-40740-FX](#) [SDCK3](#) [PIM524](#) [DEV-17737](#) [EVALAHNBIM69D130V01TOBO1](#) [1063](#) [MIKROE-2454](#) [1381](#) [MIKROE-2477](#) [1712](#)  
[175](#) [1788](#) [PGA2505EVM](#) [LM4780TABD/NOPB](#) [2130](#) [2220](#) [EVAL-ADAU1442EBZ](#) [AD8273-EVALZ](#) [2341](#) [2342](#) [2716](#) [DFR0064](#)  
[DFR0119](#) [DFR0273](#) [SEN-14262](#) [3357](#) [EV\\_ICS-40619-FX](#) [ASD2841-R](#) [EV\\_ICS-43434-FX](#) [DEV-10587](#) [3346](#) [EV\\_ICS-40618-FX](#) [GSK-](#)  
[118](#) [cs-cclassics-01](#) [EV\\_ICS-40730-FX](#) [DEV-14034](#) [EV\\_ICS-40180-FX](#) [EV\\_ICS-40310-FX](#) [3436](#) [2648](#) [BOB-12758](#) [DEV-11013](#) [TEL0108](#)