

## Sync. Rectifier Step Up Converter

### Features

- Up to 92% Efficiency at  $V_{OUT} = 5V$  from 3.3V Input
- Low Quiescent Current 100 $\mu$ A
- Guaranteed 3A Output Current at  $V_{OUT} = 5V$  from 3.3V Input
- 520KHz PWM Switching Frequency
- Synchronous and Embedded Power Mosfets; No Schottky Diode Required
- Internal Soft-Start to Limit Inrush Current
- Adjustable Output
- Output turn off true shutdown function
- Current Mode Operation with Internal Compensation for Excellent Line and Load Transient Response
- Overload/Short-Circuit Protection with hiccup control
- Shutdown Current <20 $\mu$ A
- Thermal Shutdown
- Available in SOP-8 (FD) , TSSOP-20 (FD)

### General Description

The G2118 is a compact, high-efficiency, synchronous step-up converter with power Mosfets embedded and with output turn off true shutdown function and adjustable output current limiting with foldback for a single-cell Li-ion/polymer battery. The G2118 uses only 100 $\mu$ A (typ) quiescent current and allows the converter to switch only when needed at no load and light loads, and when load is higher than 100mA, it uses fixed-frequency PWM technique at 500KHz. It features a current mode control for fast transient response with internal compensation. The G2118 includes cycle-by-cycle current limit to maximum inductor current and over-temperature protection circuit. The G2118 is suitable for iPad-like computers, smart phones and portable handheld devices.

The G2118 is available in a SOP-8 (FD) and TSSOP-20 (FD) . The operating temperature range is from -40 $^{\circ}$ C to +85 $^{\circ}$ C.

### Application

- iPad-like computers, smart phones and portable handheld devices.

### Ordering Information

ORDER NUMBER	MARKING	TEMP. RANGE	PACKAGE (Green)
G2118F11U	G2118	-40 $^{\circ}$ C to +85 $^{\circ}$ C	SOP-8 (FD)
G2118F21U	G2118	-40 $^{\circ}$ C to +85 $^{\circ}$ C	TSSOP-20 (FD)

Note: F1:SOP-8 (FD), F2:TSSOP-20 (FD),

1: Bonding Code

U: Tape & Reel

Green : Lead Free / Halogen Free.

### Pin Configuration

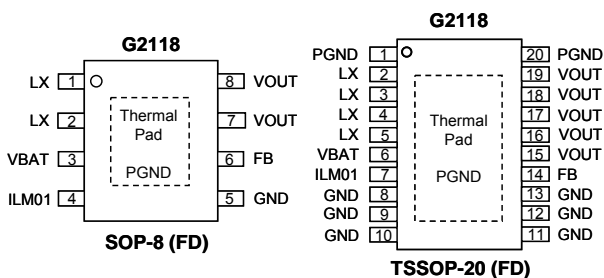

Note: Recommend connection the Thermal Pad to the PGND for excellent power dissipation.

### Typical Application Circuit

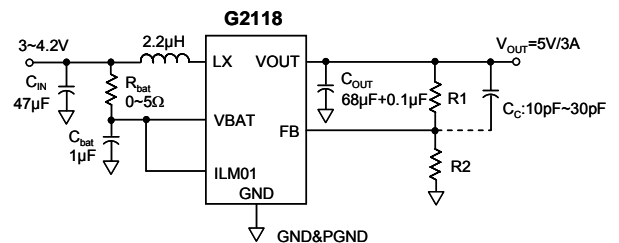

$V_{OUT} = V_{REF} * (1 + R1/R2)$ , where  $V_{REF}$  typical is 1.23V

## Absolute Maximum Ratings

V <sub>OUT</sub> to GND	-0.3V to 6V	Continuous Power Dissipation (T <sub>A</sub> = +25°C)	
LX to GND	-0.3V to 8.5V<10nS	SOP-8 (FD)	0.9W
ILM01 to GND	-0.3V to 6V	TSSOP-20 (FD)	2.1W
OC to GND	-0.3V to 6V	Storage Temperature	-55~150°C
FB to GND	-0.3V to 6V	Operation Temperature	-40~85°C
V <sub>BAT</sub> to GND	-0.3V to 6V		
Thermal Resistance of Junction to Ambient (θ <sub>JA</sub> )			
SOP-8 (FD)	132°C/W		
TSSOP-20 (FD)	60°C/W		

## Electrical Characteristics

(V<sub>OUT</sub> = 5V, V<sub>BAT</sub> = 3.6V, L = 2.2μH, C<sub>IN</sub> = 47μF, C<sub>OUT</sub> = 68μF+0.1μF, T<sub>A</sub> = 25°C)

The device is not guaranteed to function outside its operating conditions. Parameters with MIN and/or MAX limits are 100% tested at +25°C, unless otherwise specified.

DESCRIPTION	PARAMETER	CONDITIONS	MIN	TYP	MAX	UNITS
<b>General</b>						
Input operation voltage	V <sub>BAT</sub>		2.7	---	4.5	V
Output voltage	V <sub>OUT</sub>	I <sub>load</sub> =3A V <sub>bat</sub> =3.3V	---	---	5.3	V
Input Quiescent current	I <sub>BAT</sub>	V <sub>BAT</sub> = 3.6V FB > 1.25V No load, no switching (exclude input current from ILM0&ILM1)	---	100	150	μA
Shutdown supply current	I <sub>BAT</sub>	ILM01=0	---	10	20u	μA
<b>Oscillator &amp; Protection</b>						
Switching Frequency	F <sub>osc</sub>		360	520	680	KHz
Soft-Start Interval	SS		---	4	---	ms
FB Regulation Voltage	V <sub>FB</sub>		1.208	1.227	1.246	V
FB Input Current	I <sub>FB</sub>	FB=1.23V	---	---	100	nA
OC De-Glitch	T <sub>deglitch</sub>	OC flag from 1 to 0	---	4	---	ms
Startup into a short-Circuit	T <sub>precharge+</sub> T <sub>deglitch</sub>	OC flag from 1 to 0	---	10	---	ms
Restart time in SCP	T <sub>scp_restart</sub>	OC flag keep 0	---	64	---	ms
Current Limit Response Time	T <sub>oc_response</sub>		---	T <sub>osc</sub>	---	μs
Maximum Duty Cycle	D <sub>max</sub>	FB=1.2V	82	86	92	%
<b>DC-DC Switches</b>						
V <sub>OUT</sub> Leakage Current	I <sub>pVOUT_LK</sub>	ILM01=0, V <sub>OUT</sub> =5V	---	1	5	μA
LX Leakage Current	I <sub>LX_LK</sub>	ILM01=0 V <sub>OUT</sub> =5V	---	1	5	μA
Switch ON Resistance	R <sub>ON-N</sub>		---	30	---	mΩ
	R <sub>ON-P</sub>		---	40	---	
Peak Current Limit	I <sub>LIM</sub>	ILM01=1 at V <sub>BAT</sub> =4.2V	5	---	---	A
		ILM01=1 at V <sub>BAT</sub> =3V	7	---	---	
Efficiency		ILM01=1, V <sub>BAT</sub> =3.3V, V <sub>OUT</sub> =5V, I <sub>OUT</sub> =3A	---	92	---	%
<b>Protection Block</b>						
V <sub>OUT</sub> Short-Circuit Threshold	V <sub>SCP</sub>	Falling Edge	---	V <sub>OUT</sub> (1-0.25)	---	V
V <sub>OUT</sub> Short-Circuit Threshold	V <sub>SCP</sub>	Ring Edge	---	V <sub>OUT</sub> (1-0.9)	---	V
V <sub>BAT</sub> UVLO Threshold	V <sub>UVLO</sub>	Falling Edge	--	2.58	--	V
V <sub>BAT</sub> UVLO Threshold	V <sub>UVLO</sub>	Rising Edge	--	2.66	--	V
Thermal Shutdown Threshold		Rising Edge, 10°C hysteresis	---	145	---	°C
<b>Control Block</b>						
ILM01 Input High Level	V <sub>ih_ilm</sub>		1.5	---	5.5	V
ILM01 Input Low Level	V <sub>il_ilm</sub>		0	---	0.5	V
ILM01 Internal Pull-Low Resistance	R <sub>in_ilm</sub>		440	550	660	KΩ

**Minimum Footprint PCB Layout Section**

**SOP-8 (FD)**

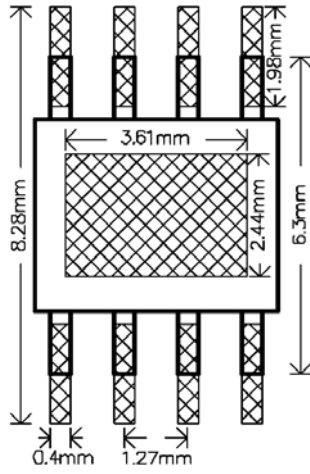

**TSSOP-20 (FD)**

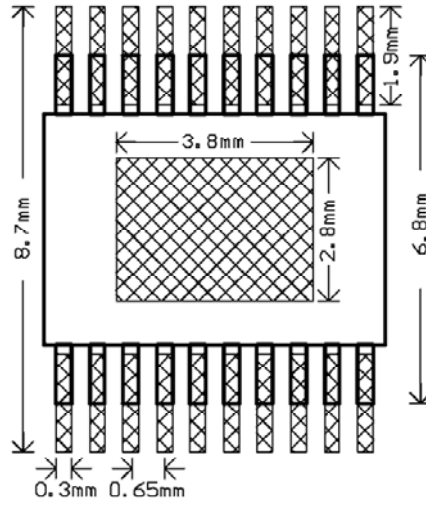

## Typical Performance Characteristics (FOR SOP-8 (FD) Package)

( $V_{BAT} = 3.6V$ ,  $V_{OUT} = 5V$ ,  $C_{IN} = 47\mu F$ ,  $C_{OUT} = 68\mu F$ ,  $L = 2.2\mu H$ ,  $T_A = 25^\circ C$ , unless otherwise noted.)

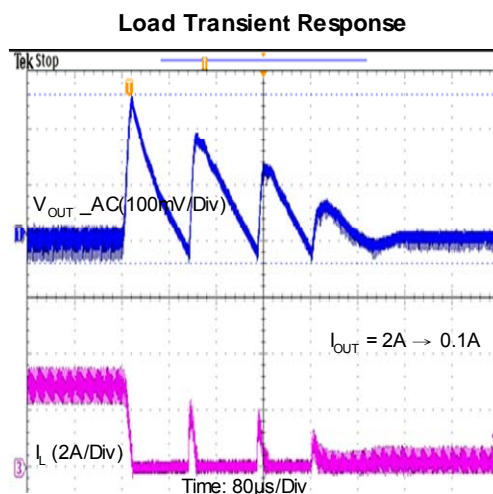
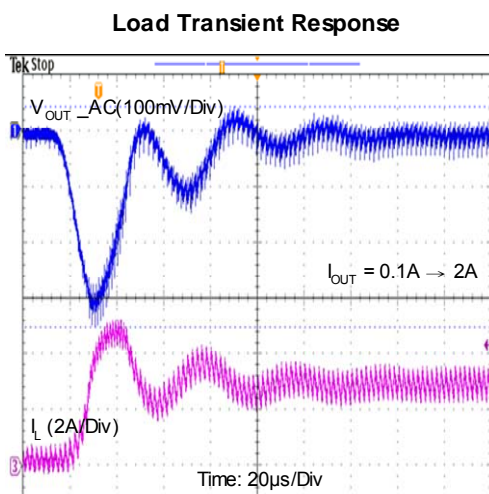
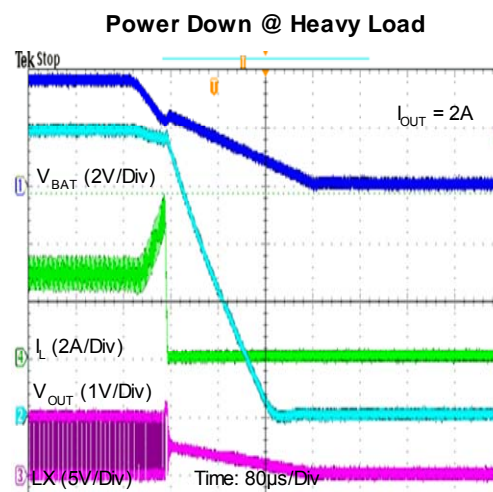
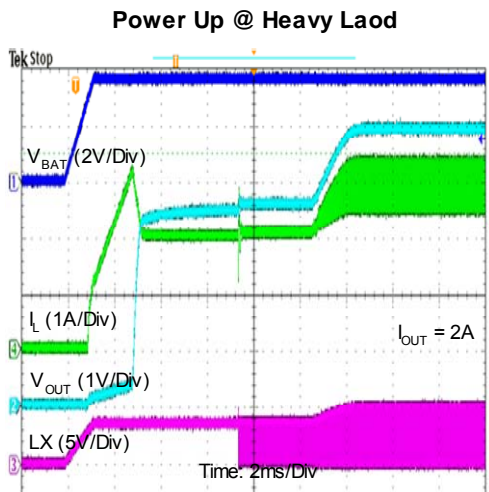
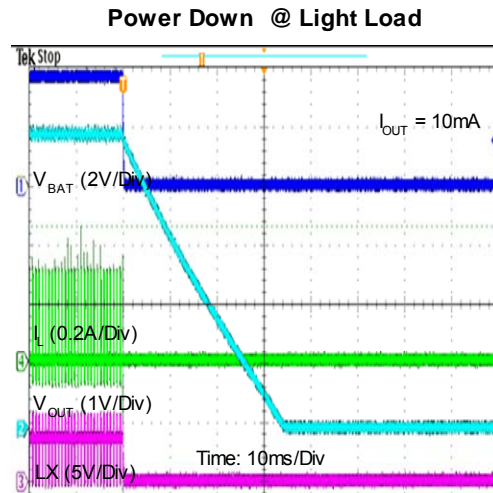
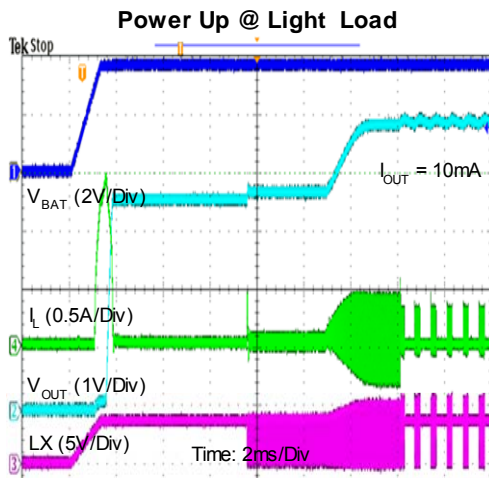

Typical Performance Characteristics (continued)

Line Transient Response

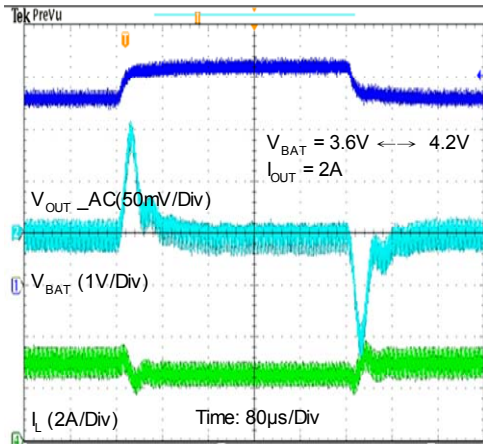

Line Transient Response

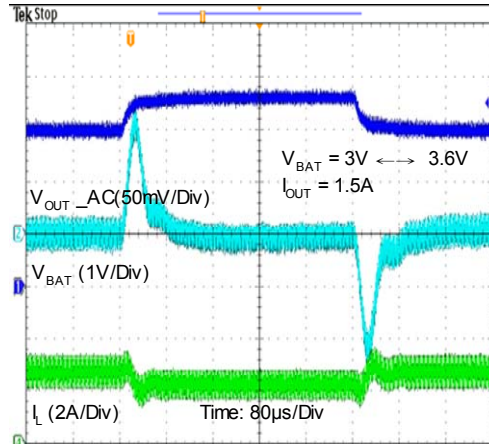

Steady State Response

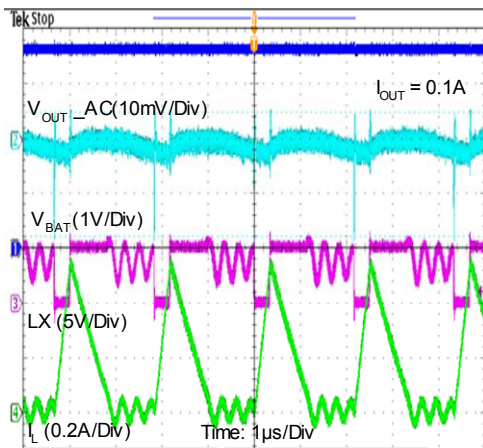

Steady State Response

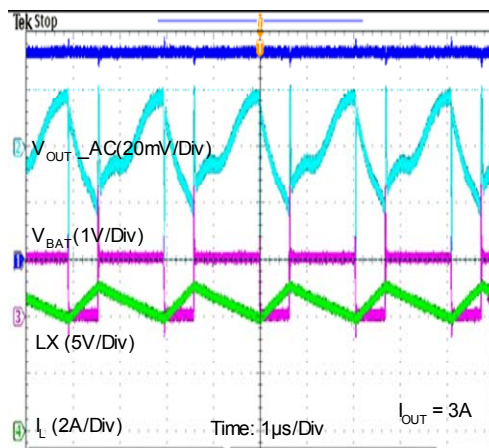

Peak Current Limit

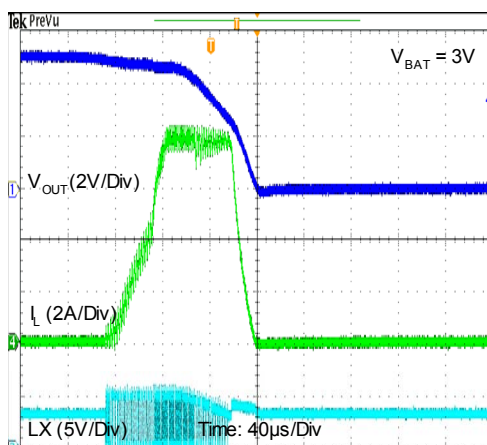

Peak Current Limit

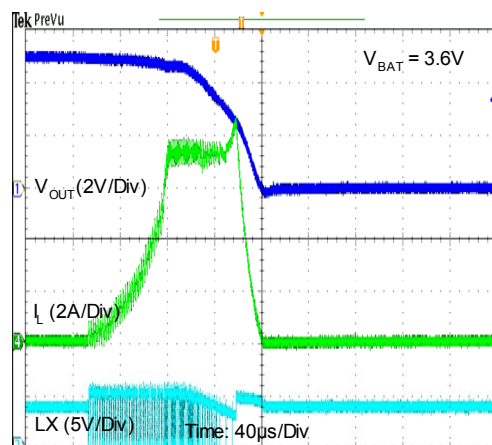



## Typical Performance Characteristics (continued)

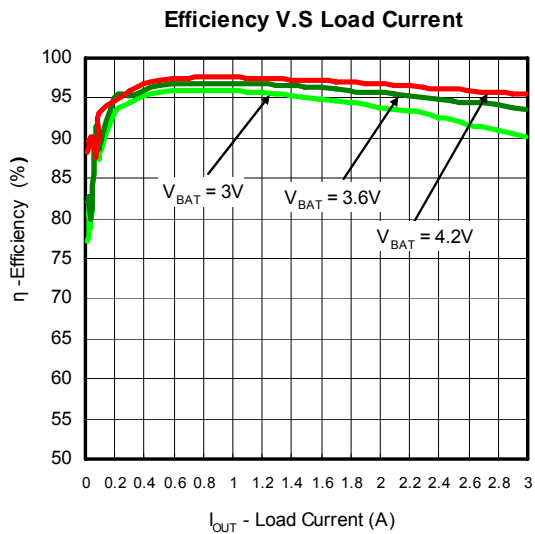
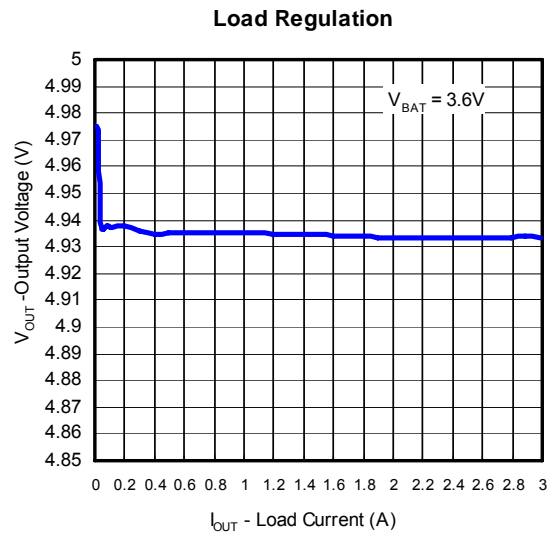
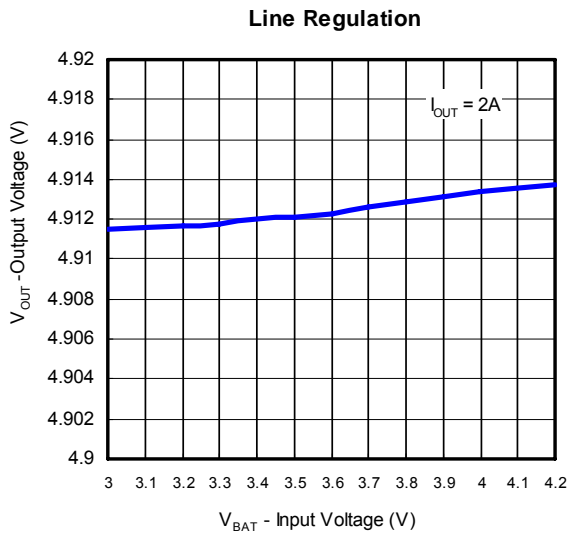
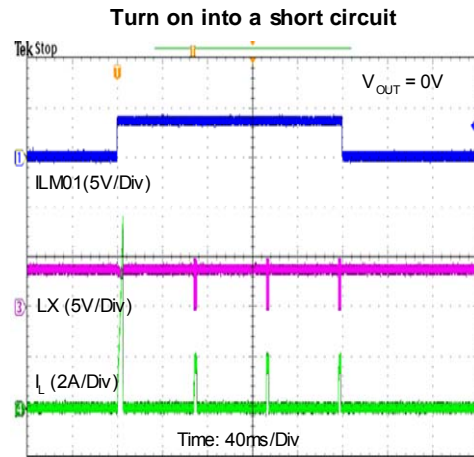
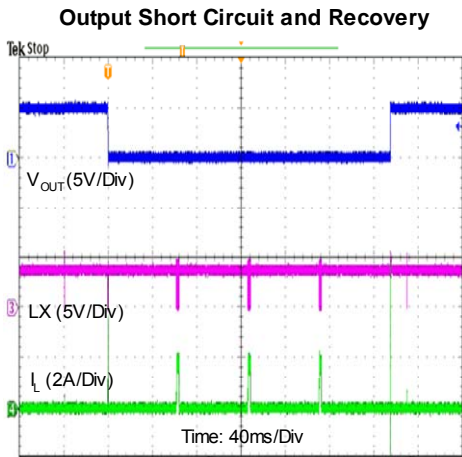

## Pin Description

### SOP-8 (FD)

PIN	NAME	FUNCTION
1,2	LX	Inductor Node.
3	VBAT	IC Power Supply Input.
4	ILM01	On/Off Control (input voltage of ILM01 can't be over 1V than VBAT)
5	GND	IC Analog Ground.
6	FB	Converter Feedback Input.
7,8	VOUT	Converter Output.
Thermal Pad	PGND	Exposed Paddle. Connect to the ground plane to optimize thermal performance. EP is internally connected to GND. EP must be connected to GND at a single point with a ground connection.

### TSSOP-20 (FD)

PIN	NAME	FUNCTION
2,3,4,5	LX	Inductor Node.
6	VBAT	IC Power Supply Input.
7	ILM01	On/Off Control (input voltage of ILM01 can't be over 1V than VBAT)
8,9,10,11,12,13	GND	IC Analog Ground.
14	FB	Converter Feedback Input.
15,16,17,18,19	VOUT	Converter Output.
1,20, Thermal Pad	PGND	Exposed Paddle. Connect to the ground plane to optimize thermal performance. EP is internally connected to GND. EP must be connected to GND at a single point with a ground connection.

## Block Diagram

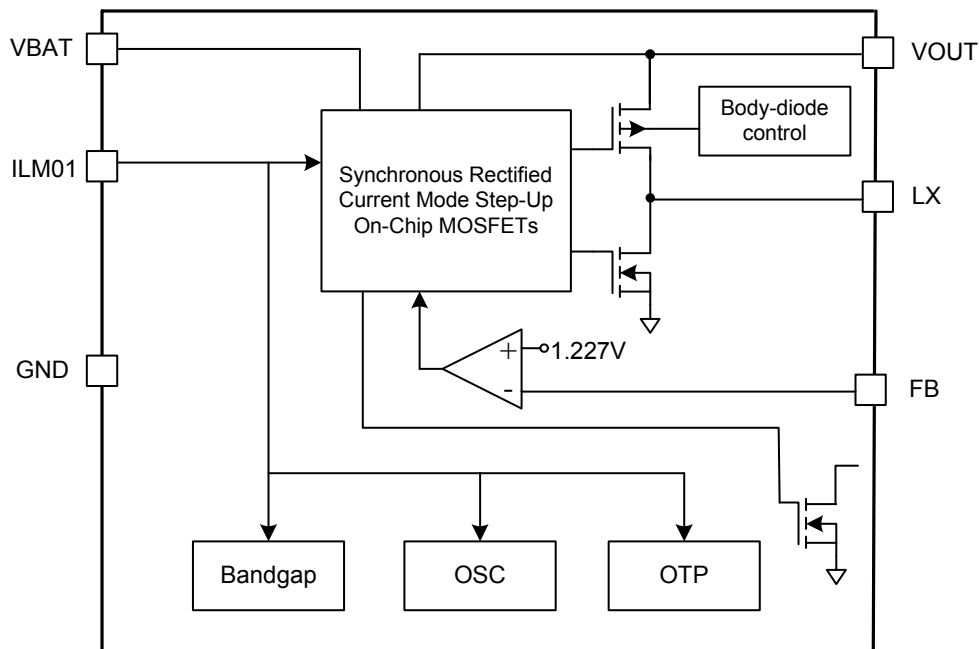

## Function Description

The G2118 current-mode step-up DC-DC switching converter uses a fixed-frequency PWM architecture with output shutdown. In light-load mode, the converter switches when needed, consuming only 100 $\mu$ A of quiescent current. In heavy-load mode of higher than 300mA, the converter switches every cycle at a constant frequency as fixed-PWM, thus enabling noise filtering. The G2118 is highly efficient, with internal and synchronous switches. Shutdown reduces the quiescent current to less than 10 $\mu$ A. Low quiescent current and high efficiency make this device ideal for portable equipment.

The G2118 step-up DC-DC switching converter typically generates a 5V output voltage from a single-cell battery input voltage. The output peak current limit is internal adjustable respectively by VBAT input voltage, as Table 1 and during the state of short-circuit after precharge is end, the converter will turn off 64ms first and then turn on 2ms cycle by cycle to protect converter under short circuit operation. Internal soft-start limits the inrush current to less than 500mA under no-load conditions during startup. The G2118 is adjustable by 2 external resistors with calculating the value for R1 as  $R1 = R2 (V_{OUT}/V_{FB} - 1)$ .

The G2118 switches at a 520KHz frequency, allowing for tiny external components. The G2118 is optimized for use in iPad-like computers, smart phones, portable handheld devices and other applications requiring low quiescent current for maximum battery life.

## PCB layout guidelines

1. It is required to place the following components as close to the G2118 as possible: CIN, COUT, L, R2 and R3, for the best efficiency and minimum noise problems.
2. For better heatsink, 4-layers board is highly recommended; if it is allowed a whole ground plane is the best option.
3. For stable and fixed reference potential, Analog GND and Power GND must be clearly isolated, star topology is recommended.
4. To avoid noise interference, voltage divider (R2 and R3), and the trace connecting to the FB pin must not be adjacent to the LX net.
5. This package incorporates an exposed thermal pad that is designed to be attached directly to an external heatsink. Solder the thermal pad to a ground plane to provide a low thermal resistance to ground for better heat dissipation.



## EV Board PCB Layout Section

Top Layer

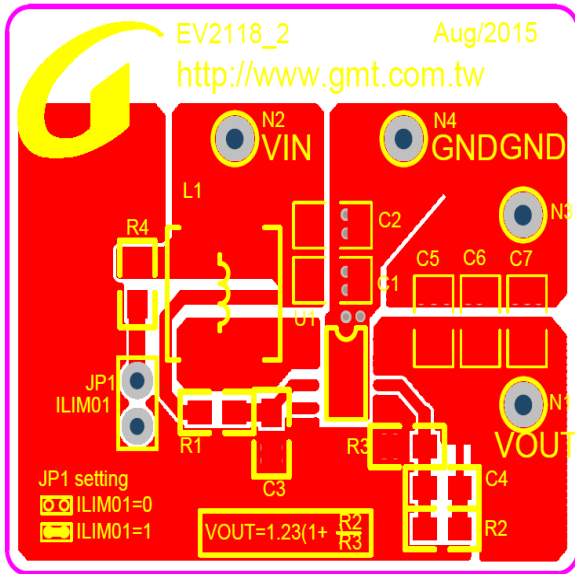

Mid Layer 1

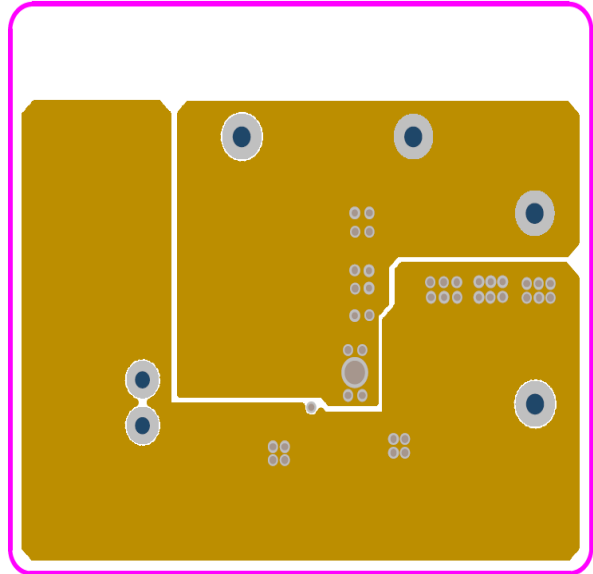

Mid Layer 2

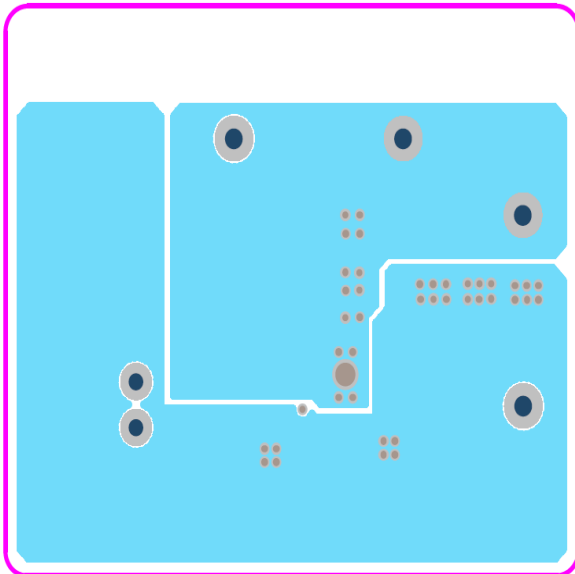

Bottom Layer

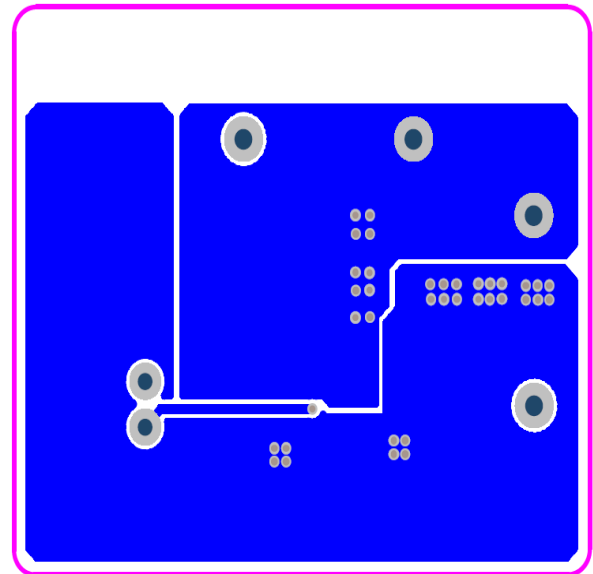

EV2118 PCB	Information
Board Material	FR4
Size	37 x 32 mm <sup>2</sup>
Board Thickness	1.6mm
Layers	4
Copper Thickness	2 oz.

## Package Information

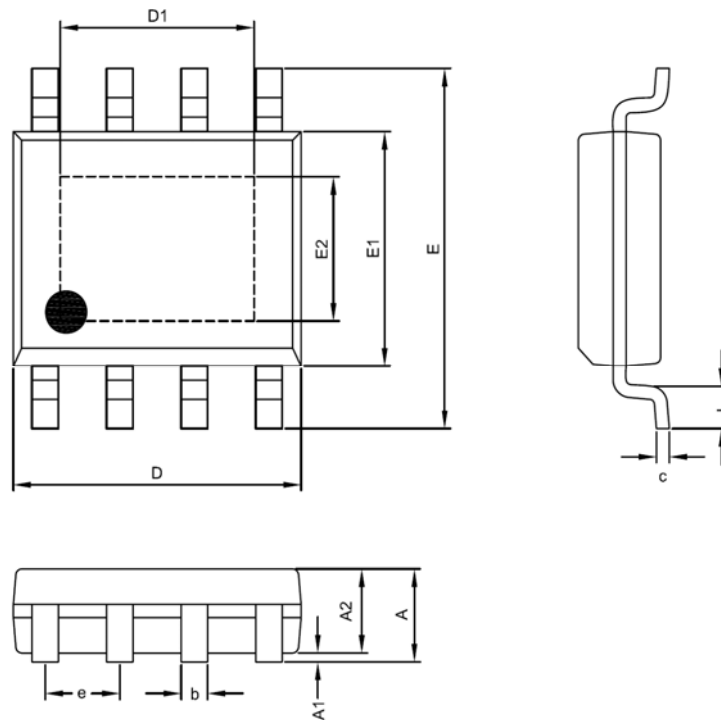

SOP- 8 (FD) Package

Symble	DIMENSION IN MM			DIMENSION IN INCH		
	MIN.	NOM.	MAX.	MIN.	NOM.	MAX.
A	1.35	1.55	1.60	0.053	0.061	0.063
A1	0.00	---	0.10	0.000	---	0.004
A2	1.15	1.35	1.50	0.045	0.053	0.059
D	4.80	4.90	5.00	0.189	0.192	0.197
D1	2.29	---	3.71	0.090	---	0.146
E	5.80	6.00	6.20	0.228	0.236	0.244
E1	3.80	3.90	4.00	0.150	0.153	0.157
E2	2.29	---	2.64	0.090	---	0.104
c	0.19	0.23	0.27	0.007	0.009	0.011
b	0.33	0.43	0.53	0.013	0.017	0.021
e	1.27 BSC			0.050 BSC		
L	0.40	0.70	1.00	0.016	0.028	0.039

## Taping Specification

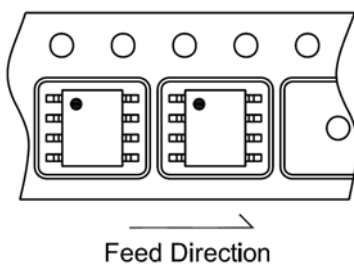

PACKAGE	Q'TY/REEL
SOP-8 (FD)	2,500 ea

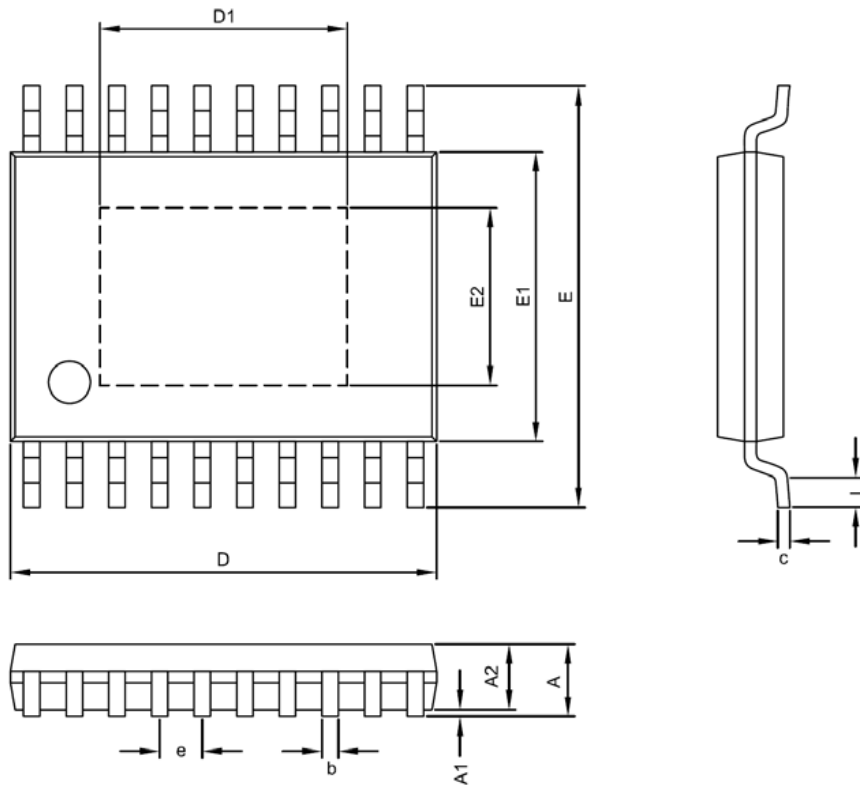
**TSSOP-20 (FD) Package**

Symble	DIMENSION IN MM			DIMENSION IN INCH		
	MIN.	NOM.	MAX.	MIN.	NOM.	MAX.
A	---	---	1.20	---	---	0.048
A1	0.00	---	0.15	0.000	---	0.006
A2	0.85	1.00	1.05	0.033	0.039	0.041
D	6.40	6.50	6.60	0.252	0.256	0.260
D1	3.80 TYP.			0.150 TYP.		
E	6.20	6.40	6.60	0.244	0.252	0.260
E1	4.30	4.40	4.50	0.169	0.173	0.177
E2	2.80 TYP.			0.110 TYP.		
c	0.09	---	0.20	0.004	---	0.008
b	0.19	0.22	0.30	0.008	0.009	0.012
e	0.65 TYP.			0.026 TYP.		
L	0.45	0.60	0.75	0.018	0.024	0.030

### Taping Specification

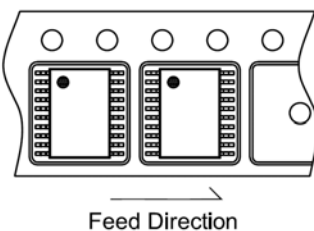

PACKAGE	Q'TY/REEL
TSSOP-20 (FD)	3,000 ea

GMT Inc. does not assume any responsibility for use of any circuitry described, no circuit patent licenses are implied and GMT Inc. reserves the right at any time without notice to change said circuitry and specifications.

## X-ON Electronics

Largest Supplier of Electrical and Electronic Components

*Click to view similar products for [Isolated DC/DC Converters](#) category:*

*Click to view products by [GMT\(Global Mixed-mode Tech\)](#) manufacturer:*

Other Similar products are found below :

[ESM6D044440C05AAQ](#) [FMD15.24G](#) [PSL486-7LR](#) [PSR152.5-7IR](#) [Q48T30020-NBB0](#) [AVO240-48S12B-6L](#) [AVO250-48S28B-6L](#) [NAN-0505](#) [HW-L16D](#) [JAHW100Y1](#) [217-1617-001](#) [22827](#) [SPB05C-12](#) [SQ24S15033-PS0S](#) [18952](#) [19-130041](#) [CE-1003](#) [CE-1004](#) [GQ2541-7R](#) [PSE1000DCDC-12V](#) [RDS180245](#) [MAU228](#) [419-2065-201](#) [449-2075-101](#) [J80-0041NL](#) [V300C24C150BG](#) [419-2062-200](#) [419-2063-401](#) [419-2067-101](#) [419-2067-501](#) [419-2068-001](#) [DCG40-5G](#) [DFC15U48D15](#) [449-2067-000](#) [XGS-0512](#) [XGS-1205](#) [XGS-1212](#) [XGS-2412](#) [XGS-2415](#) [XKS-1215](#) [033456](#) [NCT1000N040R050B](#) [SPB05B-15](#) [SPB05C-15](#) [SSQE48T25025-NAA0G](#) [L-DA20](#) [HP3040-9RG](#) [HP1001-9RTG](#) [XKS-2415](#) [XKS-2412](#)