

9A, 600kHz High Efficiency, Synchronous Boost Converter with Output Disconnect

Features

- 2.4V ~ 5.5V Input Voltage Operation.
- 98% Efficient DC/DC Converter
- 600kHz Fixed Switching Frequency
- 9A Typical Switch Current Limit
- 40uA Quiescent Current
- High Efficiency over Full Load Range
- Internal Soft-start and Compensation
- True Output Load Disconnect from Input
- Built-In OCP, SCP, OVP and OTP Protection
- AQFN2X2-14 Package.

General Description

The G2263 is a high efficiency, synchronous, current-mode, boost converter with output disconnect. The G2263 starts up from an input voltage as low as 1.9V, and maintains good performance with input voltage higher than 2.8V. The integrated P-channel synchronous rectifier improves efficiency and eliminates the need for an external Schottky diode. This P-channel disconnects the output from the input during shutdown. The G2263 provides a compact solution for a 5V output, 4A load requirement, using a supply voltage down to 2.8V. The G2263 is available in AQFN2x2-14 package.

Applications

- Battery-powered Products

Ordering Information

ORDER NUMBER	MARKING	TEMP. RANGE	PACKAGE (Green)
G2263AV1U	2263	-40°C~+85°C	AQFN2X2-14

Note: AV: AQFN2x2-14
 1: Bonding code
 U: Tape & Reel
 Green : Lead Free / Halogen Free

Pin Configuration

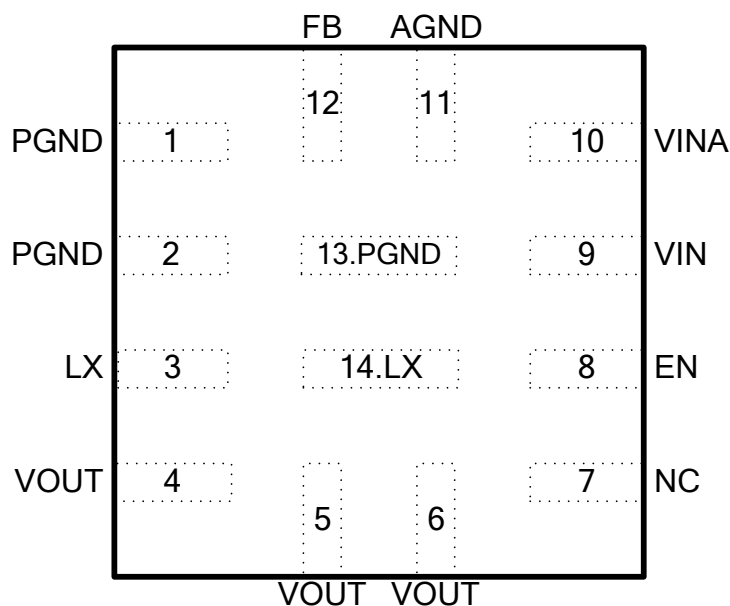

Absolute Maximum Ratings

LX -0.3V to +6.5V (11V for < 5nS)
 EN -0.3V to (V_{INA}+0.3)V
 All other Pins -0.3V to +6.3V
 Thermal Resistance Junction to Ambient, (θ_{JA})*
 AQFN2X2-1480°C/W
 Continuous Power Dissipation (T_A=25°C)
 AQFN2X2-14.1.56W

Operating Ambient Temperature -40°C to 85°C
 Storage Temperature Range. -55°C to +150°C
 Reflow Temperature (soldering, 10 sec) 260°C
 EDS Susceptibility (Human Body Mode) 2KV
 EDS Susceptibility (Machine Mode) 200V

* The package is placed on a 2-layer PCB (1oz). Please refer to EV Board PCB Layout Section

1. Stresses beyond those listed under “Absolute Maximum Ratings” may cause permanent damage to the device. These are stress ratings only and functional operation of the device at these or any other conditions beyond those indicated in the operational sections of the specifications are not implied. Exposure to absolute maximum rating conditions for extended periods may affect device reliability.
2. Device is ESD sensitive. Handling precaution recommended. The Human Body model is a 100pF capacitor discharged through a 1.5KΩ resistor into each pin.

Electrical characteristics

(V_{IN}=V_{INA}=3.3V, V_{OUT}=5V, T_A=25°C, unless otherwise specified)

PARAMETER	SYMBOL	CONDITIONS	MIN	TYP	MAX	UNIT
GENERAL						
VINA Start Operating Voltage	V _{VIN_ST}		1.9	---	5.5	V
VINA Operating Voltage	V _{VIN}		2.6	---	5.5	V
VINA Under Voltage threshold	V _{VIN_UVLO}	VIN falling	---	1.8	---	V
Stand-by Supply Current	I _{VIN}	Zero output loading of all power units	---	---	40	μA
Shutdown Current	I _{SD}	EN=0V	---	0.1	1	μA
Boost Converter						
Feedback Regulation Voltage	V _{FB}		0.788	0.8	0.812	V
Switching Frequency	F _{SW}		500	600	700	kHz
Maximum Duty Cycle	D _{MAX}		85	90	95	%
LX Leakage Current	I _{LX_LK}	V _{LX} =5.0V, V _{OUT} =0V	---	0.01	1	μA
Switch ON Resistance	R _{on-N}		---	11	---	mΩ
	R _{on-P}		---	16	---	
NMOS Current Limit	I _{LIM_SCP}	V _{OUT} < V _{SCP}	---	1.2	---	A
	I _{LIM_DOWN}	V _{SCP} < V _{OUT} < V _{IN}	---	4.5	---	A
	I _{LIM_BOOST}	V _{OUT} > V _{IN}	---	10	---	A
SCP Protection Threshold	V _{SCP}	V _{OUT}	---	0.8	---	V
OVP Protection Threshold	V _{OVP}	V _{OUT} rising	---	5.8	---	V
OVP Protection Hysteresis Voltage	V _{HYS_OVP}	V _{OUT}	---	150	---	mV
Soft-Start Internal	t _{SS}		---	1	---	mS
Control Signal						
EN Logic-Input Threshold	V _{TH}	High threshold	1.2	---	---	V
	V _{TL}	Low threshold	---	---	0.4	V
EN Input Current	I _{EN}	Connect to V _{IN}	---	10	---	nA
Protection						
Thermal Shutdown Detect	T _{SD}		---	150	---	°C
Thermal Shutdown Hysteresis	ΔT _{SD}		---	20	---	°C

Typical Performance Characteristics

($V_{IN}=V_{INA}=3.3V$, $V_{OUT}=5V$, $L1=1.5\mu H$, $T_A=25^\circ C$, unless otherwise noted.)

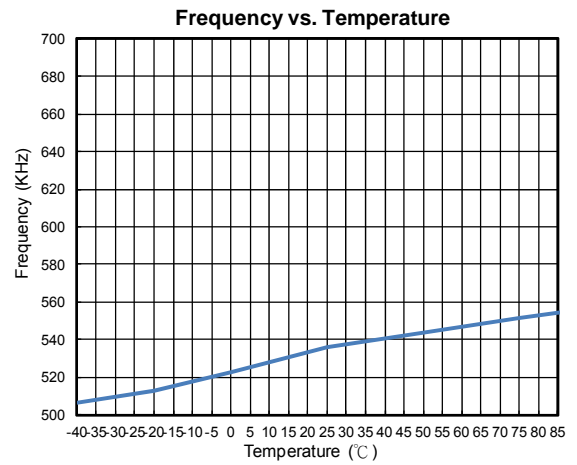
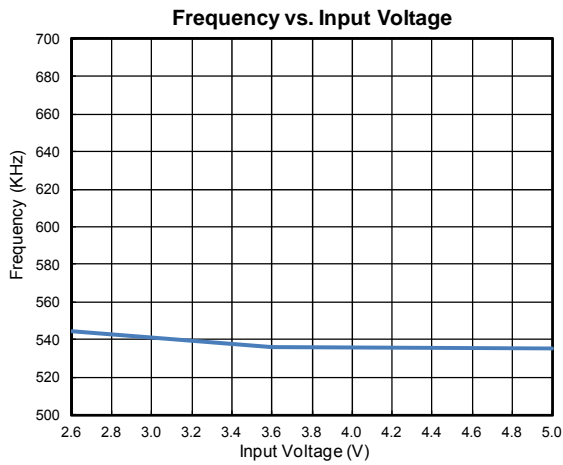
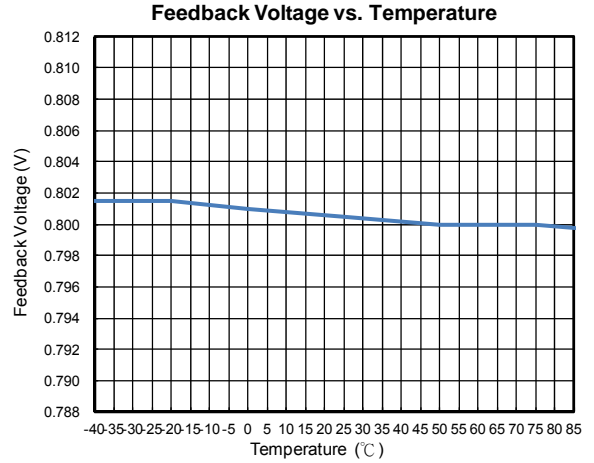
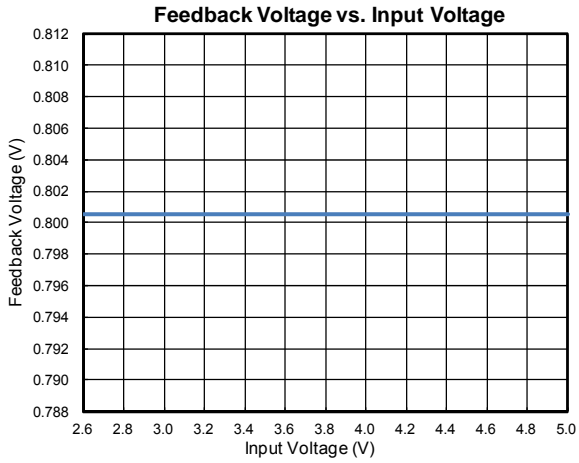
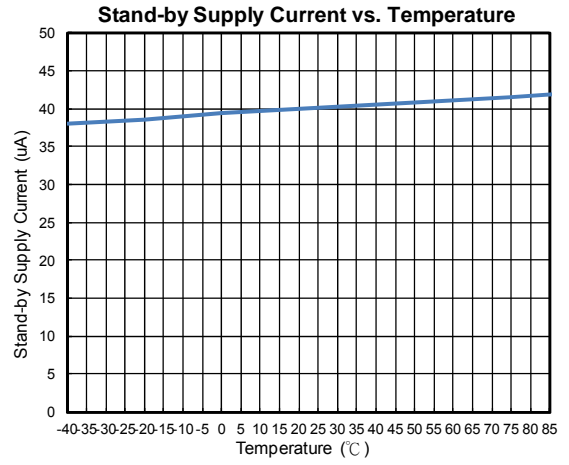
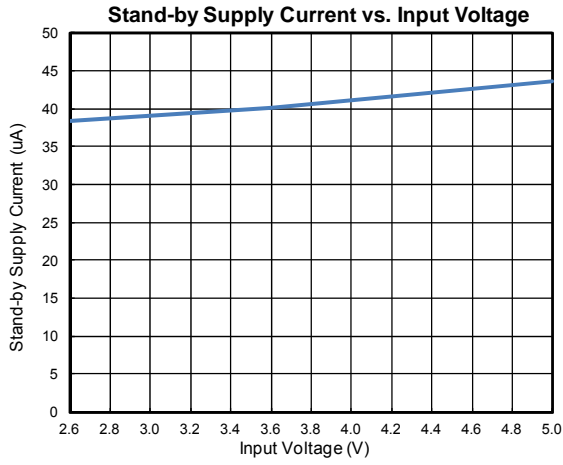

Typical Performance Characteristics (continued)

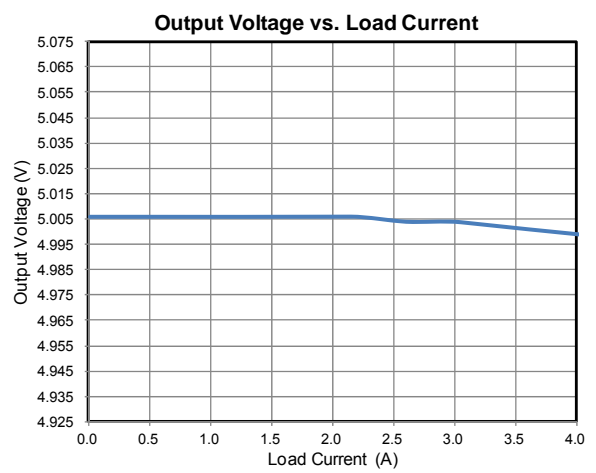
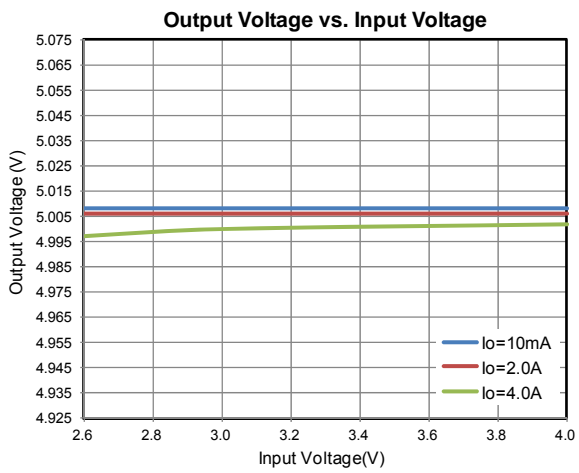
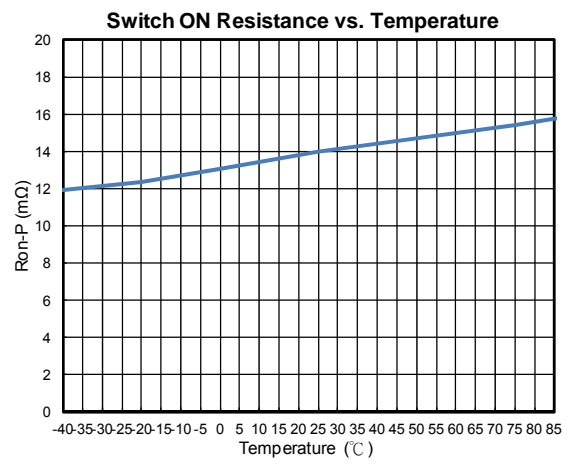
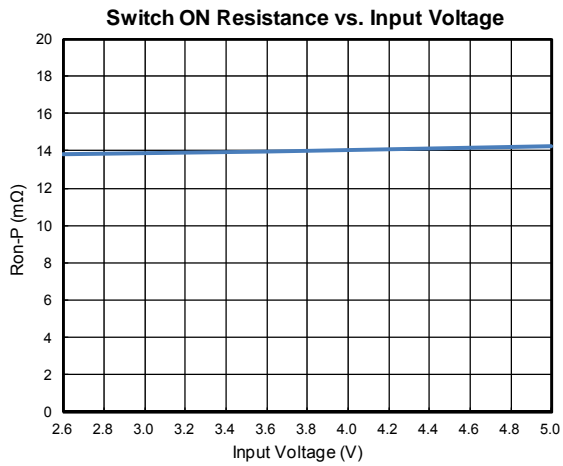
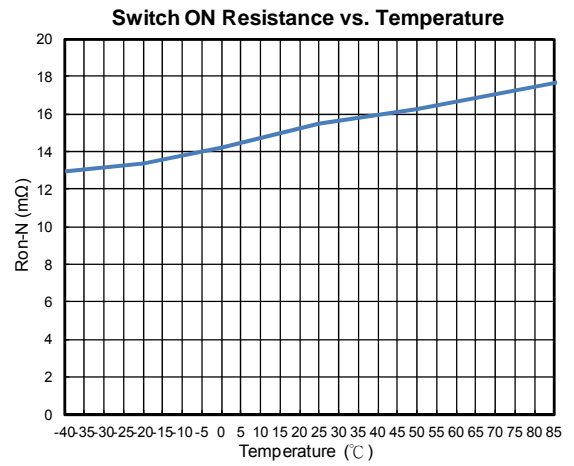
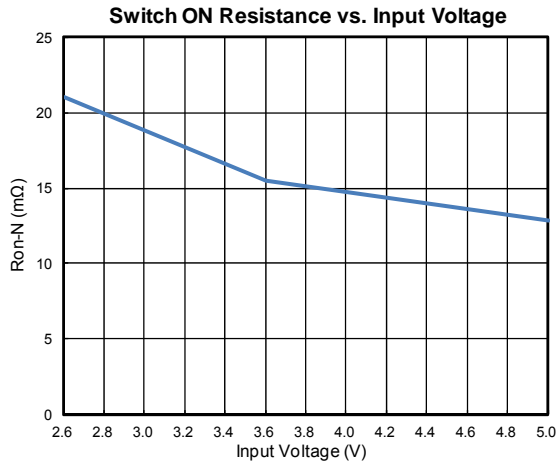

Typical Performance Characteristics (continued)

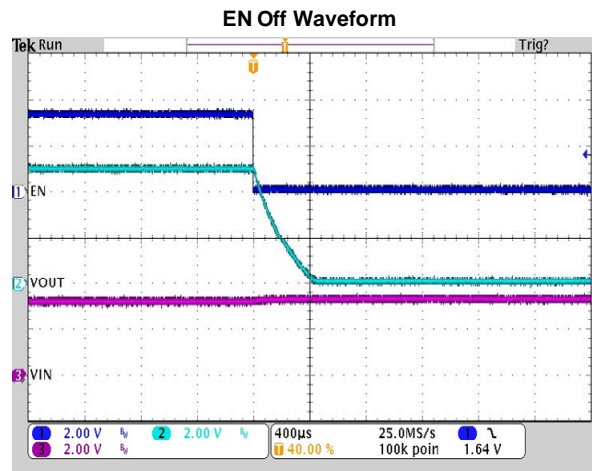
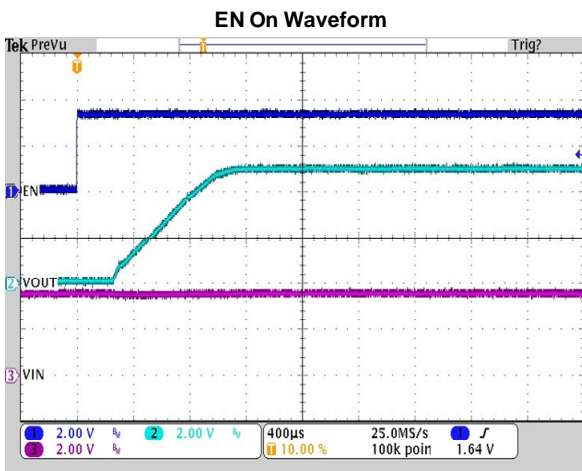
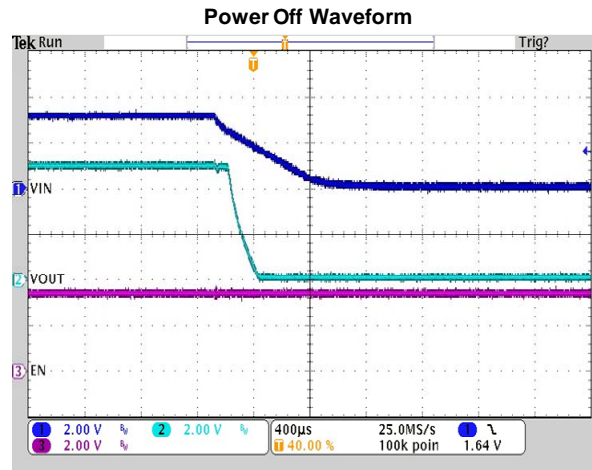
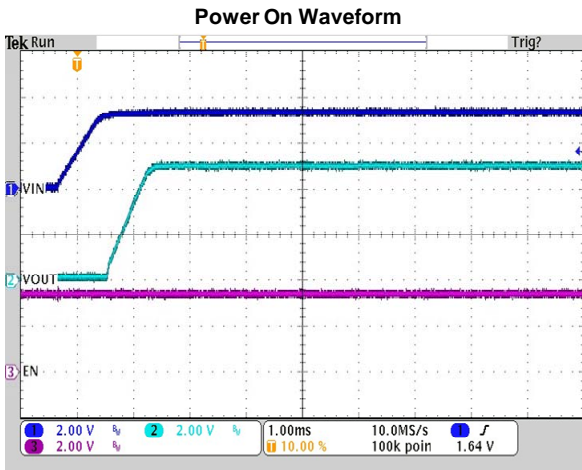
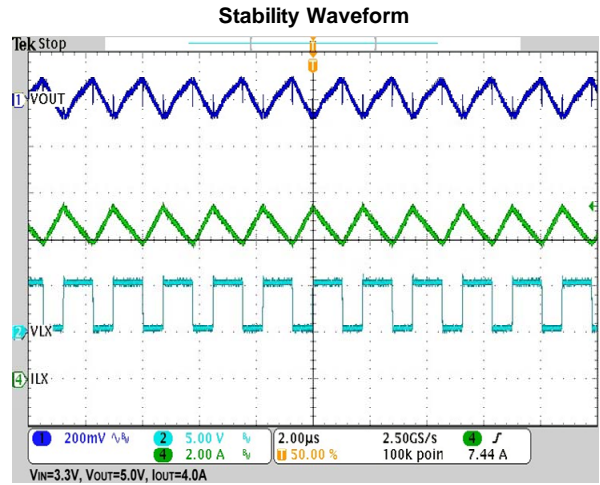
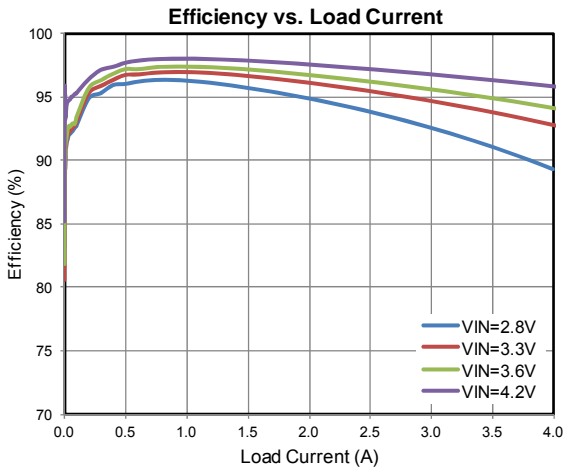

Typical Performance Characteristics (continued)

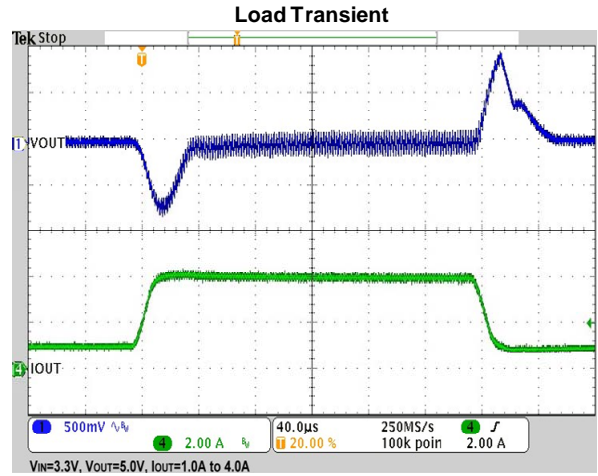
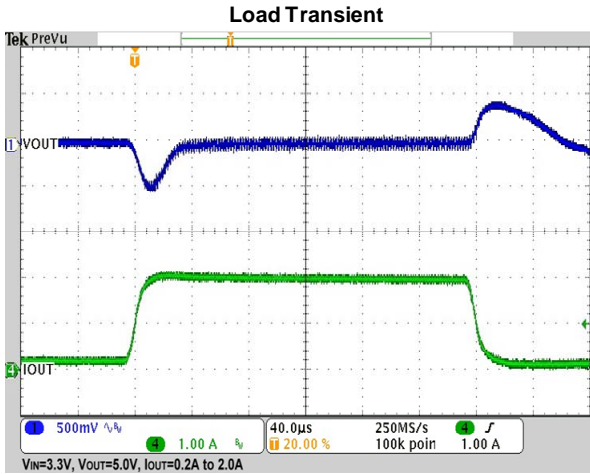

Minimum Footprint PCB Layout Section

AQFN2X2-14

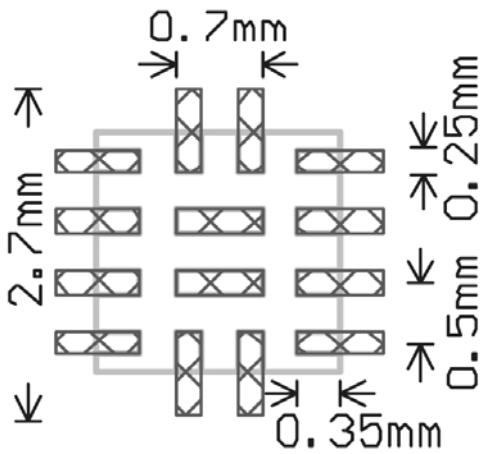

Pin Description

Pin No	Pin Name	Function
1,2,13	PGND	Power Ground.
3,14	LX	Inductor switch node of Boost Converter.
4,5,6	VOUT	Output Voltage of Boost Converter.
7	NC	No Connect. Float or connect this pin to GND in the application.
8	EN	Chip Enable Control Input. Active-H. Don't leave this pin floating in the application.
9	VIN	Power supply input of Boost Converter. Bypass with a 10uF or greater ceramic capacitor to PGND.
10	VINA	Power supply input of Chip. Bypass with a 10uF or greater ceramic capacitor to AGND.
11	AGND	Analog Signal Ground.
12	FB	Feedback Input to Error Amplifier. The output voltage can be adjusted from 2.5V to 5.5V

Block Diagram & Application Circuit

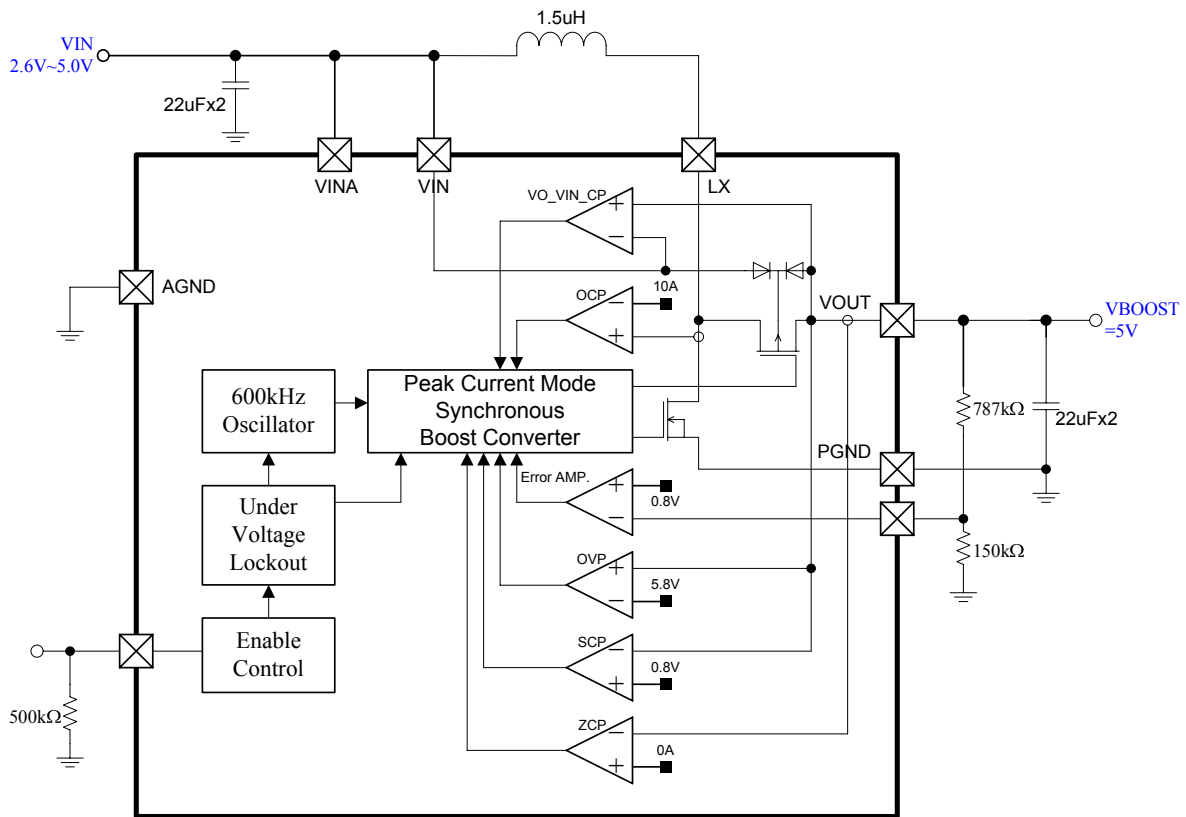

Function Description

The G2263 is a 600kHz, synchronous boost converter with true output disconnect. The device features fixed-frequency current mode PWM controls for excellent line and load regulation. Internal soft-start and loop compensation simplifies the design process and minimizes external components.

The operation of G2263 is enabled when the EN pin is toggled high and placed into shutdown mode when low. In shutdown mode, the regulator stops switching and all internal control circuitry is off. The load is isolated from the input.

When G2263 is enabled and the voltage on the VINA pin exceeds V_{VIN_UVLO} , the output stage starts switching in normal closed loop operation. In normal operation, with V_{OUT} lower than $V_{IN}+0.1V$, the G2263 operates in step-down mode with 4.5A typical peak current limit, and works in boost mode when V_{OUT} is higher than $V_{IN}+0.1V$ with 10A typical peak current limit. In step-down mode, gate of HS-FET is pulled to VIN, and it works with high impedance when HS-FET is on, the power-loss is high and regulation is band in step-down mode. The step-down mode is designed for work in startup and SCP condition, it is not suggested to set G2263 in step-down mode in normal work. The G2263 provides soft-start for V_{OUT} to ramp up from 0V to V_{OUT_SET} , and the soft start time is typically 1ms.

The G2263 automatically enter power save mode (PSM) when the load decreases and resumes PWM mode when the load increases. When the device goes into PSM, it lowers the switching frequency saving switching and driver losses, and switches to pulse skipping mode if the load continues to decrease.

The error amplifier is an internally-compensated amplifier. The EA compares the internal 0.8V reference voltage against V_{FB} to generate an error signal. The output voltage of the G2263 is adjusted by an external resistor divider. A voltage divider from V_{OUT} to ground programs the output voltage via the FB pin from 2.5V to 5.5V.

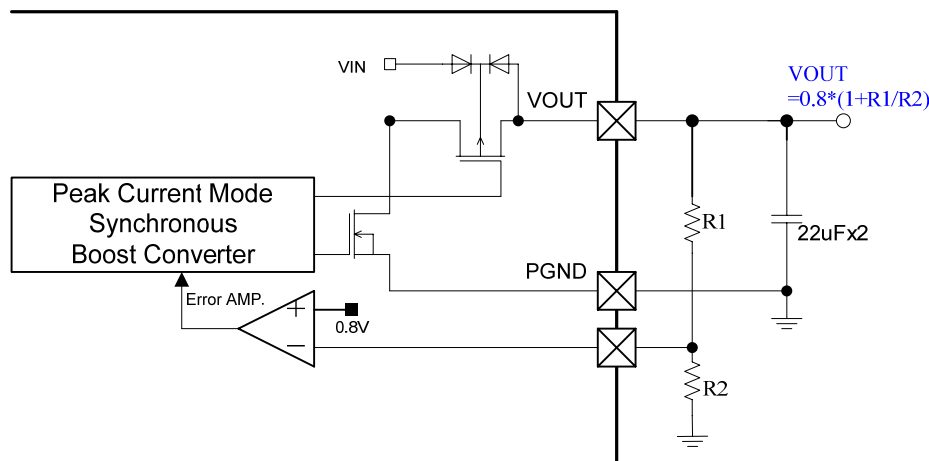

Fault Protection

G2263 provides over-current protection, over-voltage protection, short-circuit protection, and thermal shutdown protection to achieve complete protection.

Protection type	Threshold	Protection methods	Reset Method
Current Limit	NMOS current > 10A $V_{OUT} > V_{IN} + 0.1V$	NMOS Off, PMOS on	Automatic Reset at next cycle
	NMOS current > 4.5A $V_{OUT} < V_{IN} + 0.1V$	NMOS Off, PMOS on	Automatic Reset at next cycle
	NMOS current > 1.2A $V_{OUT} < V_{SCP}$	NMOS Off, PMOS on	Automatic Reset at next cycle
OVP	$V_{OUT} > 5.8V$	NMOS Off, PMOS on	Resume switching when $V_{OUT} < 5.6V$
SCP	$V_{OUT} < 0.8V$	Decrease NMOS current limit to 1.2A	Restart soft-start when $V_{OUT} > 0.8V$
TSD	Junction Temp. > 150°C	IC shutdown	Junction Temp. < 130°C

Layout Guide

As for all switching power supplies, the layout is an important step in the design, especially at high peak currents and switching frequencies. If the layout is not carefully implemented, the regulator can show noise problems and duty cycle jitter.

The inductor must be placed as close as possible to the switch pin (SW) to minimize noise coupling into other circuits. Because the feedback pin and network is a high-impedance circuit, the feedback network must be routed away from the inductor. Also, the input capacitor must be placed as close as possible to the input pin for good input-voltage filtering.

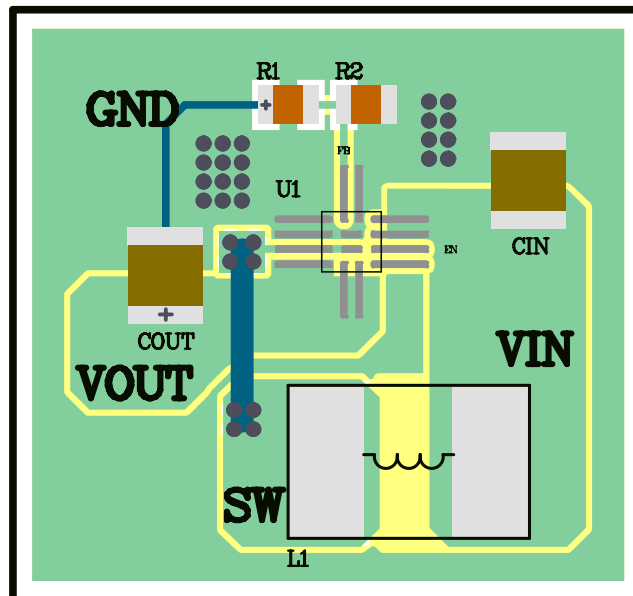

TopLayer
BottomLayer
GND

EV Board PCB Layout Section

Top Layer

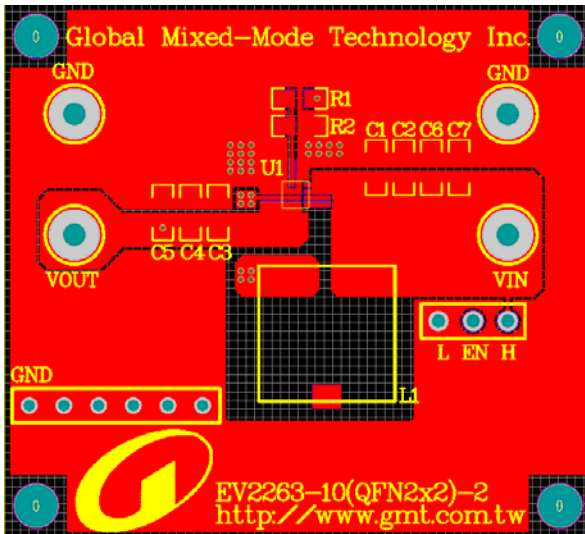

Bottom Layer

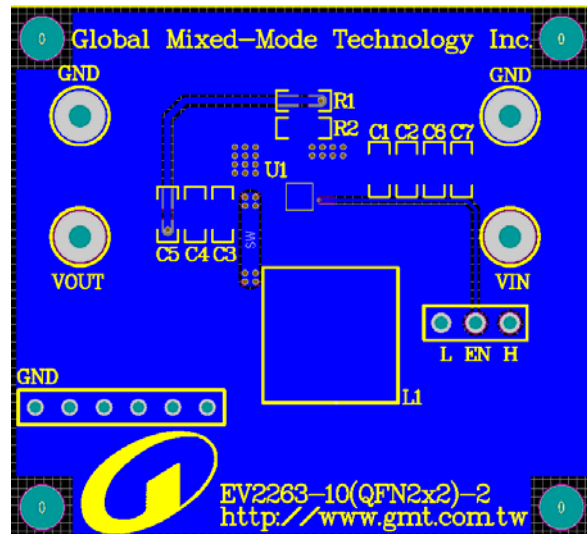

Board Information

Board Material	FR4
Size	152.4mm*101.6mm
Board Thickness	1.6mm
Layers	2
Copper Thickness	1oz.

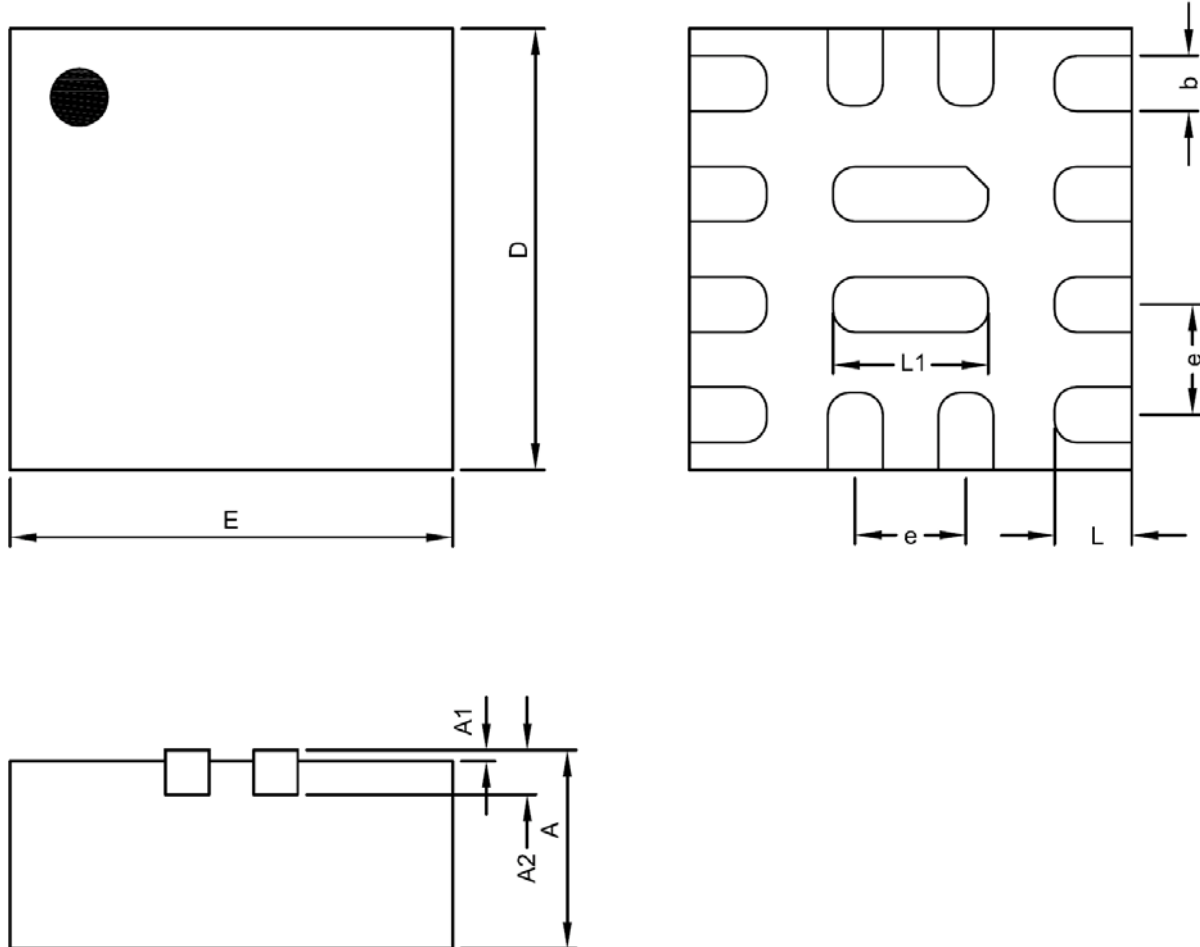
Package Information

AQFN2X2-14 Package

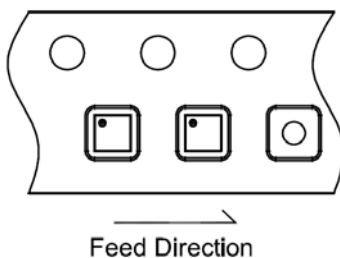
Symbol	DIMENSION IN MM			DIMENSION IN INCH		
	MIN.	NOM.	MAX.	MIN.	NOM.	MAX.
A	0.80	0.90	1.00	0.0315	0.0354	0.0394
A1	0.00	---	0.05	0.0000	---	0.0020
A2	0.20 REF			0.0079 REF		
D	1.95	2.00	2.05	0.0768	0.0787	0.0807
E	1.95	2.00	2.05	0.0768	0.0787	0.0807
b	0.20	0.25	0.30	0.0079	0.0098	0.0118
e	0.50 BSC			0.0197 BSC		
L	0.30	0.35	0.40	0.0118	0.0138	0.0157
L1	0.65	0.70	0.75	0.0256	0.0276	0.0295

Taping Specification

PACKAGE	Q'TY/REEL
AQFN2X2-14	3,000 ea

GMT Inc. does not assume any responsibility for use of any circuitry described, no circuit patent licenses are implied and GMT Inc. reserves the right at any time without notice to change said circuitry and specifications.

X-ON Electronics

Largest Supplier of Electrical and Electronic Components

Click to view similar products for [Switching Controllers](#) category:

Click to view products by [GMT\(Global Mixed-mode Tech\)](#) manufacturer:

Other Similar products are found below :

[LV5065VB-TLM-H](#) [LV5066V-TLM-H](#) [LV5725JAZ-AH](#) [633888R](#) [MP2908AGF](#) [AZ7500EP-E1](#) [NCP1012AP133G](#) [NCP1217P133G](#)
[NCP1218AD65R2G](#) [NCP1234AD100R2G](#) [NCP1244BD065R2G](#) [NCP1336ADR2G](#) [NCP1587GDR2G](#) [NCP6153MNTWG](#)
[NCP81005MNTWG](#) [NCP81101BMNTXG](#) [NCP81205MNTXG](#) [HV9123NG-G-M934](#) [IR35207MTRPBF](#) [ISL6367HIRZ](#) [CAT874-80ULGT3](#)
[SJ6522AG](#) [SJE6600](#) [TLE63893GV50XUMA1](#) [IR35215MTRPBF](#) [SG3845DM](#) [NCP1216P133G](#) [NCP1236DD65R2G](#) [NCP1247BD100R2G](#)
[NCP1250BP65G](#) [NCP4202MNR2G](#) [NCP4204MNTXG](#) [NCP6132AMNR2G](#) [NCP81141MNTXG](#) [NCP81142MNTXG](#) [NCP81172MNTXG](#)
[NCP81203MNTXG](#) [NCP81206MNTXG](#) [NX2155HCUPTR](#) [UC3845ADM](#) [UBA2051C](#) [IR35201MTRPBF](#) [MAX8778ETJ+](#)
[MAX17500AAUB+T](#) [MAX17411GTM+T](#) [MAX16933ATIR/V+](#) [NCP1010AP130G](#) [NCP1063AD100R2G](#) [NCP1216AP133G](#)
[NCP1217AP100G](#)