

100mW remote spread spectrum wireless transceiver module

Product Specification

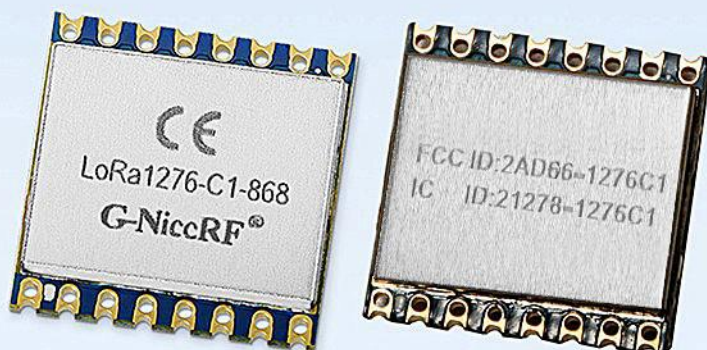

LoRa1276-C1

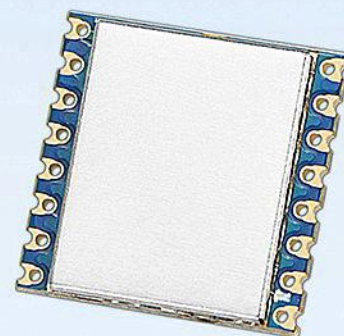

LoRa1278-C1

Catalogue

1.Overview.....	- 3 -
2.Features.....	- 3 -
3.Applications.....	- 3 -
4.Electrical Characteristics.....	- 4 -
5.Typical application circuit.....	- 5 -
6.Rate comparison table.....	- 5 -
7.Pin definition.....	- 6 -
8.Communication Antenna.....	- 7 -
9.Mechanical Dimensions (Unit:mm)	- 7 -
10.Product order information.....	- 8 -
11.Common problem.....	- 8 -
Appendix 1:SMD Reflow Chart.....	- 8 -
Appendix 2:Demo Board.....	- 9 -

Note: Revision History

Revision	Date	Comment
V1.0	2017-3	First release
V1.1	2018-12-14	Update PIN definition
V2.0	2019-7-3	Update picture
V3.0	2020-11	Modify description

1. Overview

LoRa127X-C1 integrates Semtech RF transceiver chip SX127X, which adopts LoRa Spread Spectrum modulation frequency hopping technique. Its communication distance and receiving sensitivity are much better than the current FSK and GFSK modulation. Multi-signal won't affect each other even in crowd frequency environment. It comes with strong anti-interference performance. The antenna switch is integrated and controlled by the chip. Because of the compact size and output power of 100mw, it can be widely used in wireless meter reading, remote industrial control and other industries.

LoRa127X-C1 strictly uses lead-free process for production and testing, and meets RoHS and Reach standards. LoRa1276-C1-868 have obtained CE certification ,and LoRa1276-C1-915 have get FCC ID and IC ID.

Module	Chip	Frequency band	Customized frequency range	Certification
Lora1278-C1	sx1278	433/490 MHz	Customizable 137-525 MHz	—
Lora1276-C1-868	sx1276	868 MHz	Customizable 137-1020 MHz	CE
Lora1276-C1-915	sx1276	915 MHz	Customizable 137-1020 MHz	FCC、IC

2. Features

- Frequency Range:433/490/868/915 MHz
(Customizable 137-1020 MHz)
- Sensitivity: -139dBm @Lora
- Maximum output power:20 dBm
- Low RX current: 10.8 mA
- Sleep current< 1.5uA
- Data transfer rate: 1.2-300 Kbps @FSK
0.018-37.5 Kbps @Lora
- Excellent blocking immunity
- Lora、FSK、GFSK Modulation mode
- Built-in ESD Protection
- 127 dB Dynamic Range RSSI
- Packet engine up to 256 bytes with FiFo and CRC
- Built-in temperature sensor
- Operating Temperature Range: -40 ~ +85 °C

3. Applications

- Remote meter reading
- Industrial control
- Home automation remote sensing
- Toys control
- Sensor network
- Tire pressure monitoring
- Wireless PC peripherals
- Health monitoring

4. Electrical Characteristics

Parameter	Min.	Typ.	Max.	Unit	Condition
Operation Condition					
Working voltage	1.8	3.3	3.7	V	
Temperature range	-40		85	°C	
Current Consumption					
RX current		10.8		mA	
TX current		120		mA	@20dBm
Sleep current		1		uA	
RF Parameter					
Frequency range	403	433	463	MHz	@433MHz
	470	490	510	MHz	@490MHz
	848	868	888	MHz	@868MHz
	900	915	940	MHz	@915MHz
Data rate	1.2		300	Kbps	FSK
	0.018		37.5	Kbps	LoRa
Output power	-1		20	dBm	
Receiving sensitivity		-123		dBm	@FSK data=1.2kbps, Fdev=10kHz
		-139		dBm	@Lora BW=125KHz_SF = 12_CR=4/5

Note: According to the design of the module, the maximum bit of register 0x09 must be set as 1. PaSelect must be set 1 to ensure that the PA of the module is in the open state and work at the maximum power.

RegPaConfig (0x09)	7	PaSelect	rw	0x00	Selects PA output pin 0 → RFO pin. Output power is limited to +14 dBm. 1 → PA_BOOST pin. Output power is limited to +20 dBm
	6-4	MaxPower	rw	0x04	Select max output power: $P_{max}=10.8+0.6*MaxPower$ [dBm]
	3-0	OutputPower	rw	0x0f	$P_{out}=P_{max}-(15-OutputPower)$ if PaSelect = 0 (RFO pin) $P_{out}=17-(15-OutputPower)$ if PaSelect = 1 (PA_BOOST pin)

5. Typical application circuit

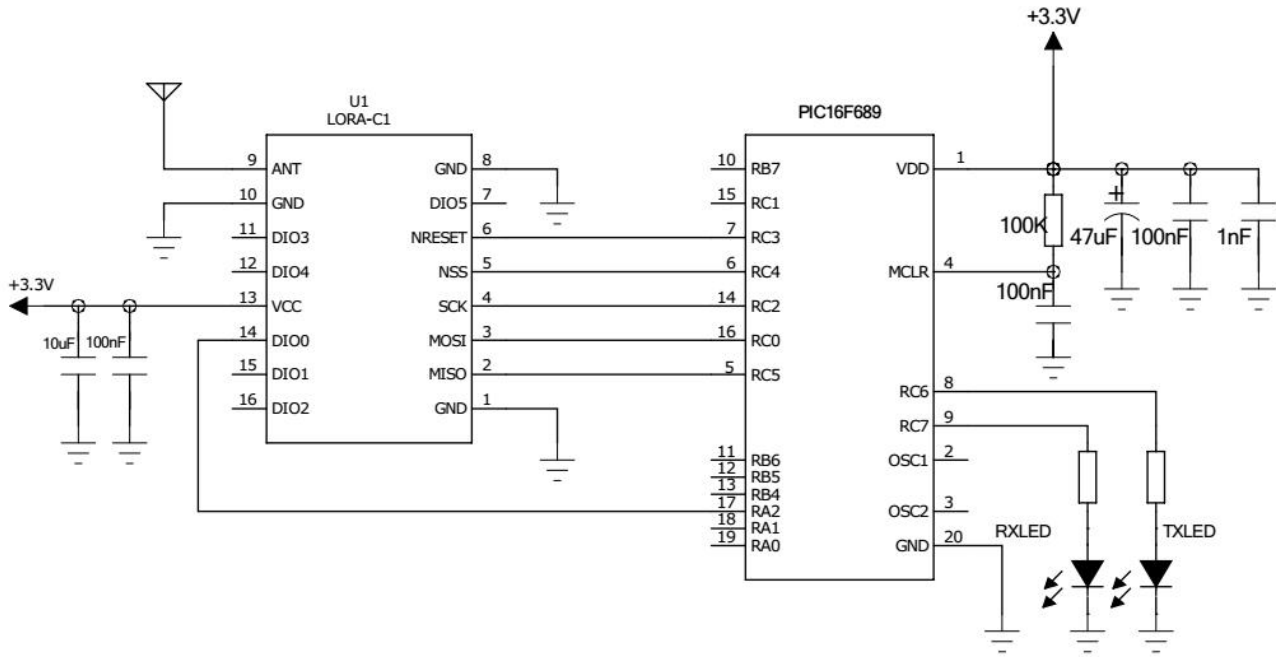

6. Rate comparison table

SignalBandWidth	SpreadingFactor	Sensitivity(dbm)	ActualBandRate(bps)
62.5kHz	SF=7	-126	2169
62.5kHz	SF=8	-129	1187
62.5kHz	SF=9	-132	656
62.5kHz	SF=10	-135	296
62.5kHz	SF=11	-137	164
62.5kHz	SF=12	-139	91
125kHz	SF=7	-123	4338
125kHz	SF=8	-126	2375
125kHz	SF=9	-129	1312
125kHz	SF=10	-132	733
125kHz	SF=11	-133	328
125kHz	SF=12	-136	183
250kHz	SF=7	-120	8676
250kHz	SF=8	-123	4750
250kHz	SF=9	-125	2624
250kHz	SF=10	-128	1466
250kHz	SF=11	-130	778
250kHz	SF=12	-133	366
500kHz	SF=7	-118	17353
500kHz	SF=8	-121	9501
500kHz	SF=9	-124	5249
500kHz	SF=10	-127	2932
500kHz	SF=11	-129	1557
500kHz	SF=12	-130	830

7. Pin definition

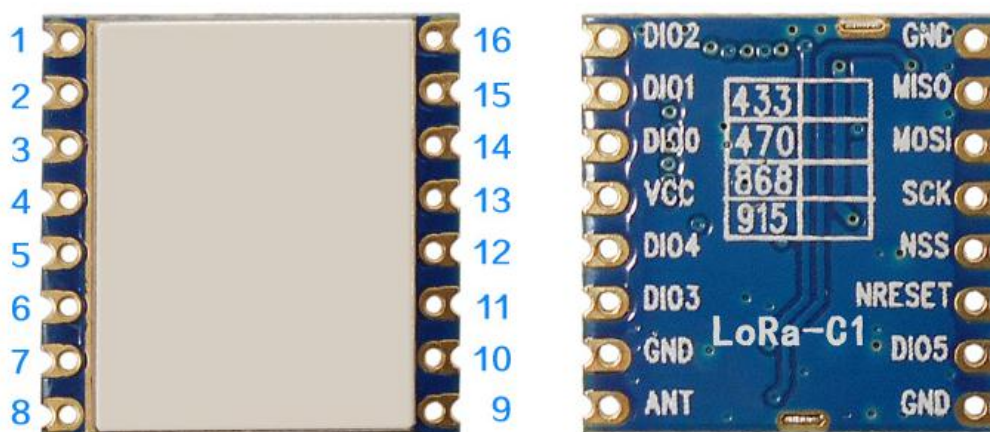

Pin NO.	Pin name	Description
1	GND	power ground
2	MISO	SPI Output for SPI data
3	MOSI	SPI Input for SPI data
4	SCK	Serial clock for SPI interface
5	NSS	SPI enable
6	NRESET	Reset input
7	DIO5	Digital I/O, customizable
8	GND	power ground
9	ANT	Connect with 50 ohm coaxial antenna
10	GND	power ground
11	DIO3	Digital I/O, customizable
12	DIO4	Digital I/O, customizable
13	VCC	Connected power supply (default 3.3V)
14	DIO0	Digital I/O, customizable
15	DIO1	Digital I/O, customizable
16	DIO2	Digital I/O, customizable

8. Communication Antenna

Antenna is very important for RF communication, its performance will affect the communication directly. Module needs antenna in 50ohm.SMA can also be used to transfer straight/elbow/folded rod.Users can order accordingly. To ensure module in the best performance, we suggest to use the our antenna.

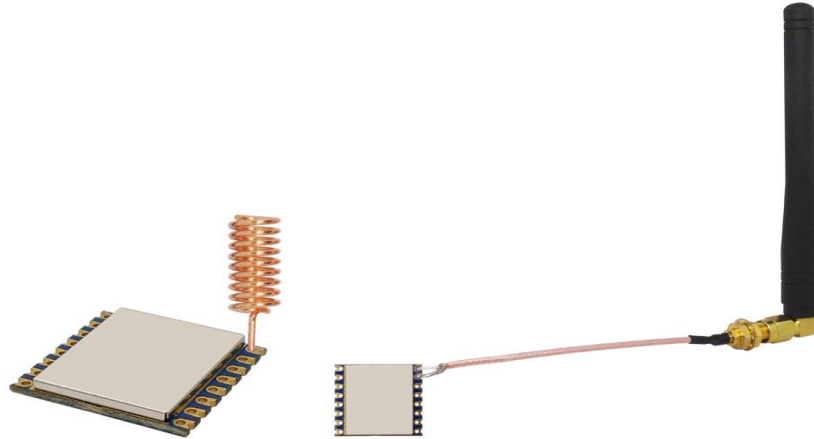

★ To ensure modules get the best performance, user must obey the following principles when using the antennas:

- Put the antenna away from the ground and obstacles as possible as you could;
- If you choose the sucker antenna, pull straight the lead wire as possible as it can be, the sucker under arches should be attached on the metal object.

9. Mechanical Dimensions (Unit:mm)

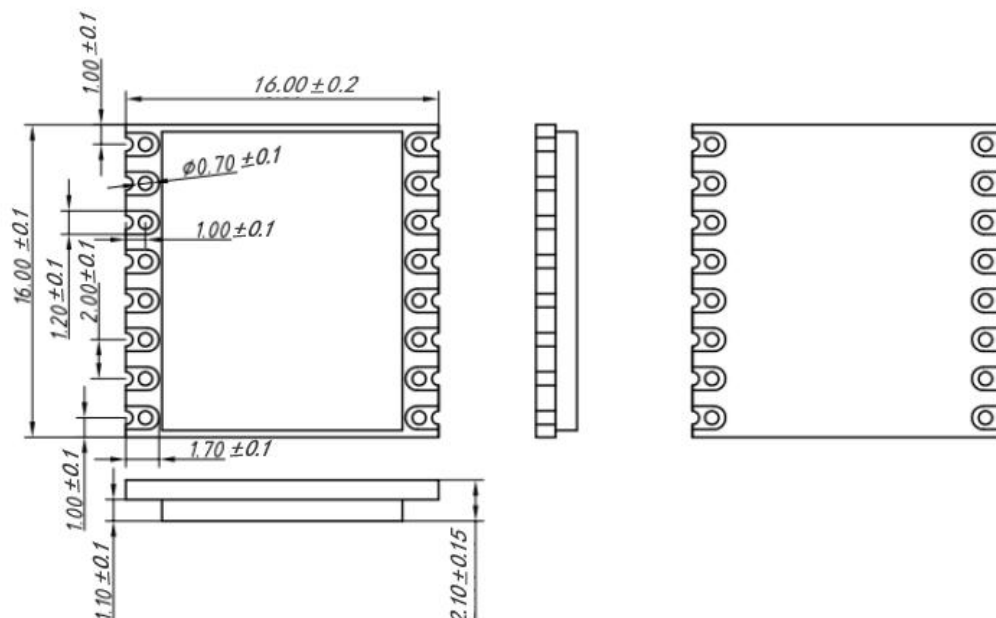

10. Product order information

For example: If the customer needs 868MHz Frequency, the order no. shall be LORA1276-C1-868.

Product Name	Description
LoRa1278-C1-433	sx1278chip, Working frequency 433MHz
LoRa1278-C1-490	sx1278chip, Working frequency 490MHz
LoRa1276-C1-868	sx1276chip, Working frequency 868MHz
LoRa1276-C1-915	sx1276chip, Working frequency 915MHz

11. Common problem

- a) Why can't the normal communication between the modules?
 - 1) The power connection is wrong and the module is not working normally;
 - 2) Check whether the frequency bands of each module and other RF parameters are consistent;
 - 3) Whether the module is damaged.
- b) Why is the transmission distance not far?
 - 1) The power supply ripple is too large;
 - 2) The antenna type is not matched or installed incorrectly;
 - 3) Surrounding co-channel interference;
 - 4) The surrounding environment is harsh and there are strong interference sources.

12. Appendix 1:SMD Reflow Chart

We recommend you should obey the IPC related standards in setting the reflow profile:

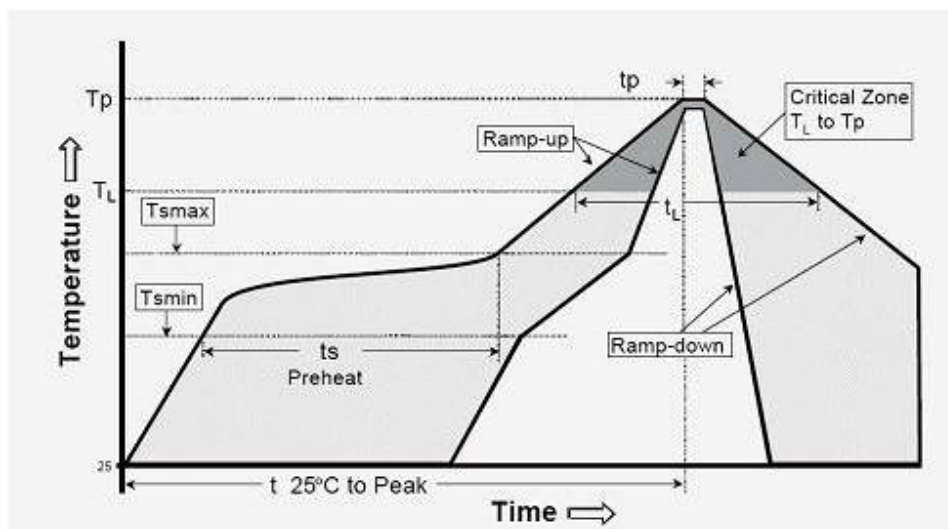

IPC/JEDEC J-STD-020B the condition for lead-free reflow soldering	big size components (thickness $\geq 2.5\text{mm}$)
The ramp-up rate (Tl to Tp)	3°C/s (max.)
preheat temperature	
- Temperature minimum (T _{min})	150°C
- Temperature maximum (T _{max})	200°C
- preheat time (t _s)	60~180s
Average ramp-up rate(T _{max} to T _p)	3°C/s (Max.)
- Liquidous temperature(T _L)	217°C
- Time at liquidous(t _L)	60~150 second
peak temperature(T _p)	245+/-5°C

13. Appendix 2: Demo Board

The module is equipped with a standard DEMO board for customer to debug the program and test distance. The power supply voltage range: 3.3V~6.0V. It shows as below:

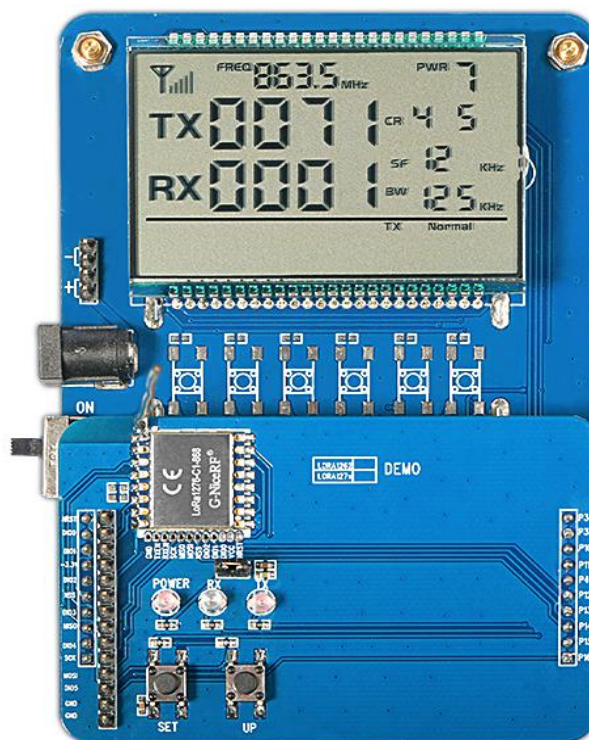

The LCD Full Segment is as below:

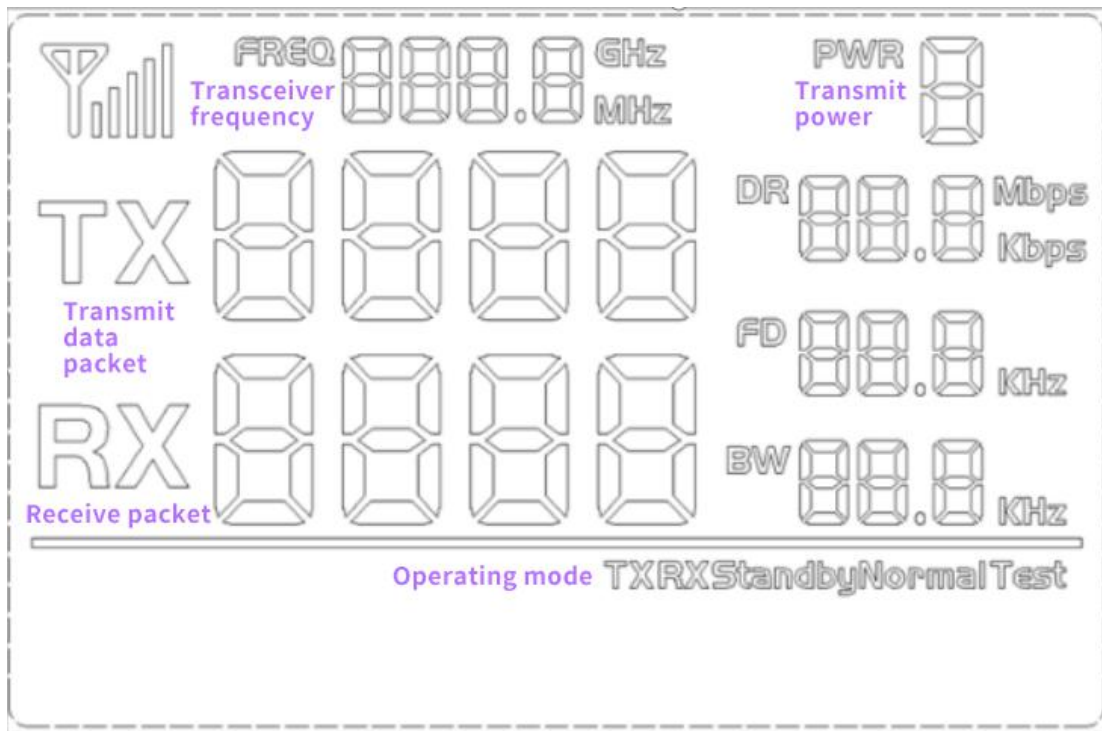

The users can set the parameters of the RF module such as frequency /transmitter power / transmission data rate through the buttons.

➤ Working Mode

- 1) Tx normal mode: send data packets regularly (In the setting mode, data packets will not be sent);
- 2) Rx normal mode: Power on and enter the receive state, receive data packets, and then send out the correctly received data packets;
- 3) Tx Test Mode: RF module continuously transmit signal;
- 4) Rx Test Mode: RF module is always in Rx mode;
- 5) Standby Mode: RF module is always in standby state.

➤ Button Operation:

- 1) [SET] Button

Press the key to enter the setting mode. If the last parameter is set, the key will exit the setting mode.

- 2) UP /Down Button

In setting mode, pressed to modify the corresponding setting parameters.

Note: The DEMO board has FLASH memory inside, all the setting parameters will behave automatically and keep unchanged even power-off.

X-ON Electronics

Largest Supplier of Electrical and Electronic Components

Click to view similar products for [Sub-GHz Modules](#) category:

Click to view products by [G-NiceRF](#) manufacturer:

Other Similar products are found below :

[SM1231E868](#) [WISE-4610-S672NA](#) [DL-SX1278PA](#) [VGdd79T433N0M2](#) [VGdd79S433X0M1](#) [VG2373S915N0S1](#) [Ra-08](#) [E220-400M22S](#)
[E22-230T22S](#) [E220-400T22S](#) [WH-L101-L-C](#) [Ra-09H\(IN865\)](#) [E22-400T30S](#) [E22-900T33S](#) [E28-2G4M27SX](#) [E28-2G4T12S](#) [E22-230T22D](#)
[E32-433T20D](#) [E22-900T30S](#) [VG2389S490N0S1](#) [E22-400T37S](#) [USR-LG206-L-P](#) [RG-02\(CN470\)](#) [RG-02\(EU868\)](#) [Ra-09H\(US915\)](#) [E22-](#)
[230T33S](#) [E220P-400T22S](#) [E106-433G27P2](#) [E220-900T22D](#) [E32-433T20S](#) [E220-400M30S](#) [E78-470LN22S\(6601\)](#) [E28-2G4M12SX](#) [E220-](#)
[400R30D](#) [E77-400M22S](#) [E220-900T30D](#) [E32-400M30S](#) [E22-900M30S](#) [E22-400T33D](#) [E150-400T30S](#) [E28-2G4T27SX](#) [E220-900M30S](#)
[E220-900M22S](#) [E52-400NW22S](#) [E22-400MM22S](#) [E32-400M20S](#) [E32-433T33S](#) [E22-230T37S](#) [E22-900MM22S](#) [E52-900NW22S](#)