

High Fidelity Wireless Audio Module

Product Specification

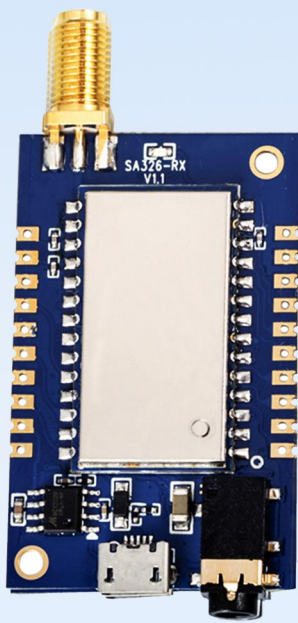

SA326-RX



SA326-TX

Catalogue

1. Overview.....	3
2. Features.....	3
3. Applications.....	3
4. Internal block diagram.....	3
5. Electrical Characteristics.....	4
6. Product configuration description.....	5
7. Module interface description.....	7
8. Pin definition.....	8
9. Mechanical size (unit: mm).....	10
Appendix: Furnace temperature curve diagram.....	12

Note: Revision History

Revision	Date	Comment
V1.0	2021-7	First release
V1.1	2022-4	Add product configuration instructions

1. Overview

SA326 series products are divided into transmitter module SA326-TX and receiver module SA326-RX. This product is an application board for SA316-TX and SA316-RX modules. It can work after power-on. You can also directly set the frequency of the module with PC software. , Sound size and other parameters, greatly simplify the user's development difficulty, this product is widely used in occasions with relatively high sound quality requirements.

2. Features

- UHF frequency band: 868 MHz
- UHF frequency band: 500~980 MHz
- VHF frequency band: 160~270 MHz
- The transmission distance is 200 meters in the open area
- Receiving sensitivity: -96 dBm
- Audio signal to noise ratio: 96 dB
- Frequency response: 20 Hz-20 KHz
- The delay from microphone input to audio output is less than 3ms
- Digital modulation method: pi/4 DQPSK
- Occupied bandwidth: <300 KHz
- Transmission rate 204.8 Kbps
- Sampling rate: 48 KHz

3. Applications

- Wired speakers become wireless speakers
- wireless microphone
- Wireless Headphones
- High-quality wireless audio transmission

4. Internal block diagram

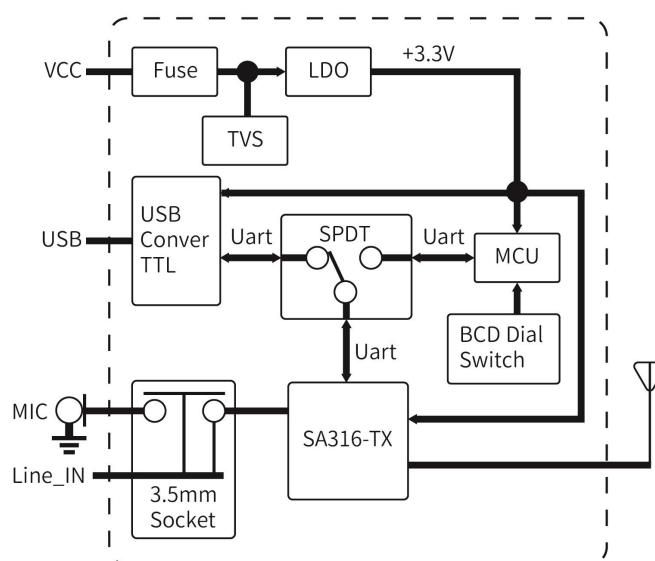

SA326-TX block diagram

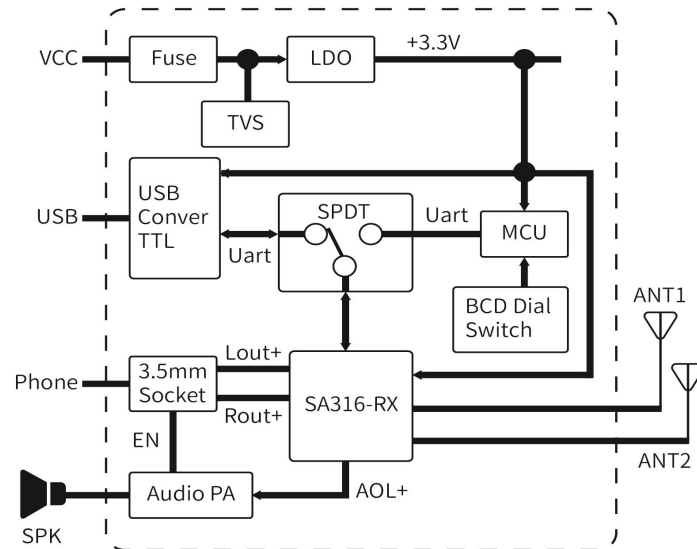

SA326-RX block diagram

5. Electrical Characteristics

Parameter	Test Conditions	Min.	Typ.	Max.	Unit
Operating voltage range		3.3	4.2	6	V
Range of working temperature		-20	25	60	°C
Operating frequency range		852.02		867.02	MHz
Audio transmission and reception delay			4		ms
Serial port baud rate			9600		bps
Current consumption					
Sleep current(SA326-RX)			<45		uA
Sleep current(SA326-TX)			<45		uA
Receive current (SA326-RX)	@VCC=4.2V		< 140		mA
Emission current (SA326-TX)			< 150		mA
Transmit parameter					
Transmit power	@VCC=4.2V	0	10		dBm
Emission bandwidth(BW)			300		KHz
Adjacent channel power ratio (ACPR)	@600KHZ		-60		dBc
Maximum microphone input voltage			0.3	1.5	V _{rms}
Audio frequency response range		20		20k	Hz
Receive parameters					
Receiving sensitivity			-96		dBm

Audio output amplitude (differential)		400	mVrms
Audio output drive resistance		600	Ohm
Signal to Noise Ratio (SNR)	@1KHz, Vmic=-30dBv	96	dB
Total harmonic distortion (THD)	@48K sampling rate, Vmic=-30dBv	0.03	%

6. Product configuration description



- 1) Version: Firmware Version of module 1.2
- 2) Channel: 1-16channel can be chose

The channel that configures SA326 needs external power supply.

Each frequency band is divided into 16 channels, with a difference of 1MHz between adjacent channels. The specific corresponding frequencies are shown in the table below:

frequency band	channel	1	2	3	4	5	6	7	8
500-515	frequency	500	501	502	503	504	505	506	507
	channel	9	10	11	12	13	14	15	16
	frequency	508	509	510	511	512	513	514	515
frequency band	channel	1	2	3	4	5	6	7	8
852-867	frequency	852	853	854	855	856	857	858	859
	channel	9	10	11	12	13	14	15	16
	frequency	860	861	862	863	864	865	866	867

- 3) Output Power: 0-10dBm ; default: 10dBm

- 4) Input Source: MIC or IIS; default: MIC
- 5) Format: when use IIS , you can choose High Bits or Low Bits
- 6) Net ID: you can set ID of each module
- 7) Volume: high low of voice, default: 37%
- 8) Signal Strength Threshold: Sound volume preset value. When the emitted sound is larger than this value, it can be emitted. the smaller the more sensitive



- 1) Version: Firmware Version of module 1.4
- 2) Channel: 1-16channel can be chose

The channel that configures SA326 needs external power supply.

Each frequency band is divided into 16 channels, with a difference of 1MHz between adjacent channels. The specific corresponding frequencies are shown in the table below:

frequency band	channel	1	2	3	4	5	6	7	8
500	frequency	500	501	502	503	504	505	506	507
	channel	9	10	11	12	13	14	15	16
515	frequency	508	509	510	511	512	513	514	515
frequency band	channel	1	2	3	4	5	6	7	8
852	frequency	852	853	854	855	856	857	858	859
	channel	9	10	11	12	13	14	15	16
867	frequency	860	861	862	863	864	865	866	867

- 3) Anti-Howl: There will be noise when the microphone and speaker are close together. Default OFF.

- 4) Input Source: MIC or IIS; default: MIC
- 5) Format: when use IIS , you can choose High Bits or Low Bits
- 6) Net_ID: you can set ID of each module
- 7) Power_Saving: power saving mode, default: off
- 8) Volume: high low of voice, default: 77%
- 9) Signal Strength Threshold: Sound volume preset value. When the emitted sound is larger than this value, it can be played. The smaller the more sensitive.

7. Module interface description

➤ SA326-TX

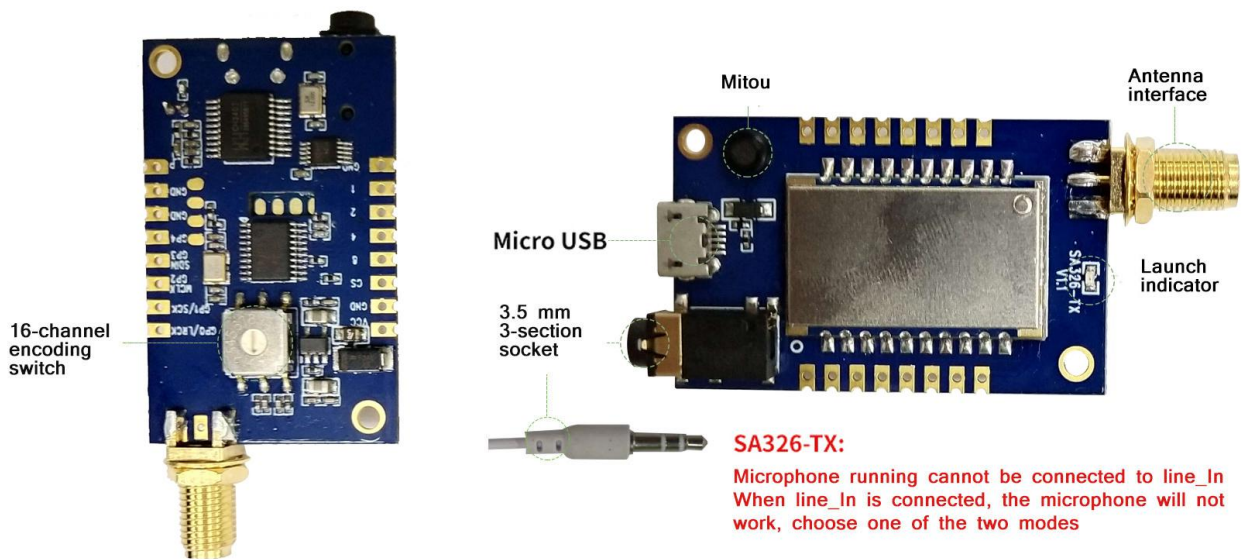

SA326-TX:
 Microphone running cannot be connected to line_In
 When line_In is connected, the microphone will not work, choose one of the two modes

➤ SA326-RX

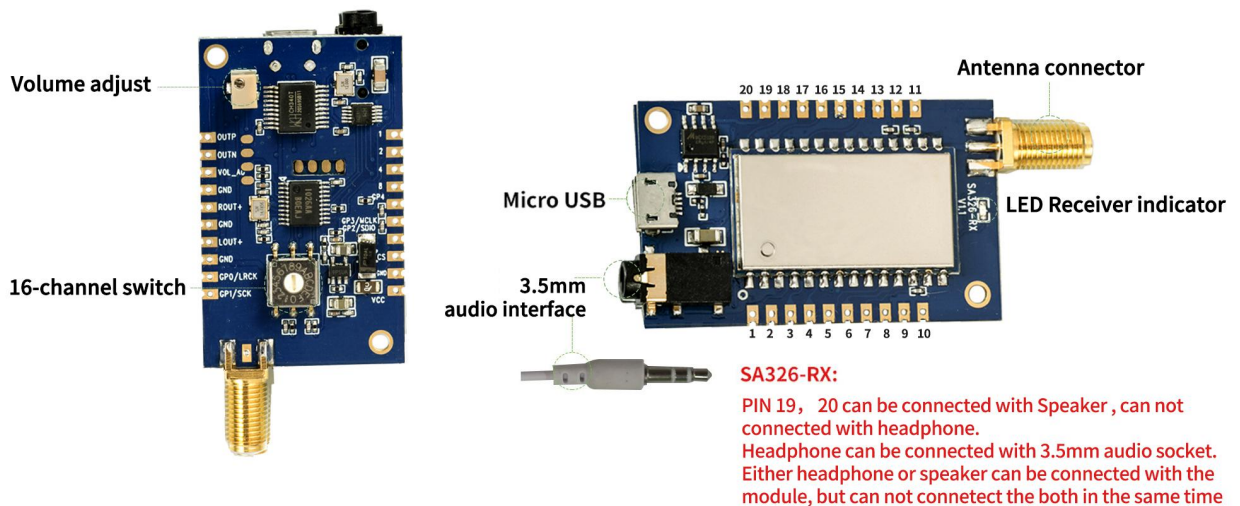

SA326-RX:
 PIN 19, 20 can be connected with Speaker , can not connected with headphone.
 Headphone can be connected with 3.5mm audio socket.
 Either headphone or speaker can be connected with the module, but can not connect the both in the same time

8. Pin definition

➤ SA326-TX

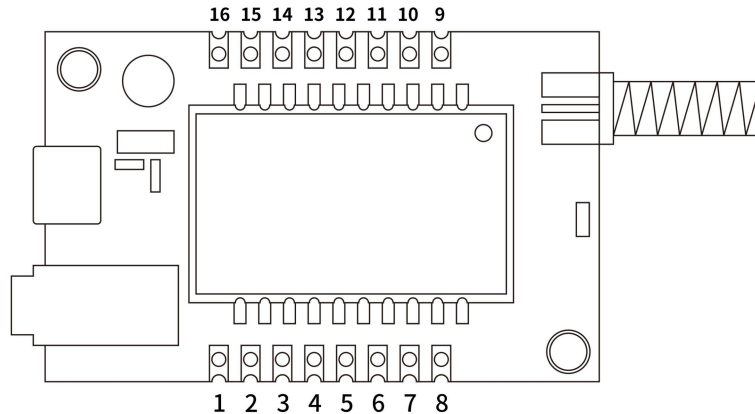

Pin NO.	Pin name	I/O	Level standard	Description
1	GND		0	Connect the negative pole of the power supply
2	1	I	0-3.3V	Frequency 16 channel 8421 encoding, the first digit, default "1" output
3	2	I	0-3.3V	Frequency 16-channel 8421 encoding, the second bit, default "1" output
4	4	I	0-3.3V	Frequency 16 channel 8421 encoding, the 8th bit, default "1" output
5	8	I	0-3.3V	Frequency 16 channel 8421 encoding, the 4th bit, default "1" output
6	CS	I/O	0-3.3V	Internally connected to the EN of the LDO, pull down the dormancy, internal pull-up, default "1" output
7	GND		0	Connect the negative pole of the power supply
8	VCC		3.3-6V	The positive pole of the external power supply. (Typical value 4V)
9	GPIO0	I/O	0-3.3V	Internally connected to GPIO0 of SA316-TX, when using I2S mode, it can be configured as LRCK
10	GPIO1	I/O	0-3.3V	Internally connected to GPIO1 of SA316-TX, when using I2S mode, it can be configured as SCK
11	GPIO2	I/O	0-3.3V	Internally connected to GPIO2 of SA316-TX, when using I2S mode, it can be configured as MCLK
12	GPIO3	I/O	0-3.3V	Connect to GPIO3 of SA316-TX, it can be configured as SDIN when using I2S mode
13	GPIO4	I/O	0-3.3V	GPIO4 with internal audio chip
14, 15	GND		0	Connect the negative pole of the power supply
16	MIC_P	I		Microphone input positive terminal, (the best signal is less than 300mVrms)

➤ SA326-RX

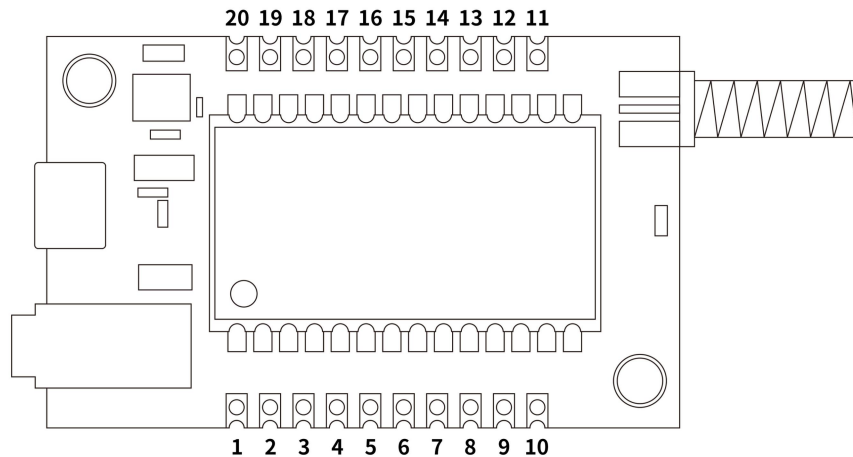

Pin NO.	Pin name	I/O	Level standard	Description
1	1	I	0-3.3V	Frequency 16 channel 8421 encoding, the first digit, default "1" output
2	2	I	0-3.3V	Frequency 16-channel 8421 encoding, the second bit, default "1" output
3	4	I	0-3.3V	Frequency 16 channel 8421 encoding, the 8th bit, default "1" output
4	8	I	0-3.3V	Frequency 16 channel 8421 encoding, the 4th bit, default "1" output
5	GPIO4	I/O	0-3.3V	Connect to GPIO4 of SA316-RX
6	GPIO3	I/O	0-3.3V	Internally connected to GPIO3 of SA316-RX, it can be configured as MCLK when using I2S mode
7	GPIO2	I/O	0-3.3V	Internally connected to GPIO2 of SA316-RX, when using I2S mode, it can be configured as SDIO
8	CS	I/O	0-3.3V	Internally connected to the EN of the LDO, pull down the dormancy, internal pull-up, default "1" output
9	GND	I	0	Connect the negative pole of the power supply
10	VCC	I	3.3-6V	The positive pole of the external power supply. (Typical value 4V)
11	GPIO1	I/O	0-3.3V	Internally connected to GPIO1 of SA316-RX, when using I2S mode, it can be configured as SCK
12	GPIO0	I/O	0-3.3V	Internally connected to GPIO0 of SA316-RX, when using I2S mode, it can be configured as LRCK
13	GND	I	0	Connect the negative pole of the power supply
14	LOUT+	O		Connect to LOUT+ of SA316-RX, which can directly drive earphones

15	GND	I	0	Connect the negative pole of the power supply
16	ROUT+	O		Connect to ROUT+ of SA316-RX, which can directly drive earphones
17	GND	I	0	Connect the negative pole of the power supply
18	VOL-ADJ	I	3.3V	Volume adjustment pin, the module has been connected to a 50K ohm adjustable potentiometer, and an external potentiometer can be connected
19	SPKN	O		Power amplifier output pin, external 4 ohm or 8 ohm 2W speaker
20	SPKP	O		Power amplifier output pin, external 4 ohm or 8 ohm 2W speaker

9. Mechanical size (unit: mm)

➤ SA326-TX

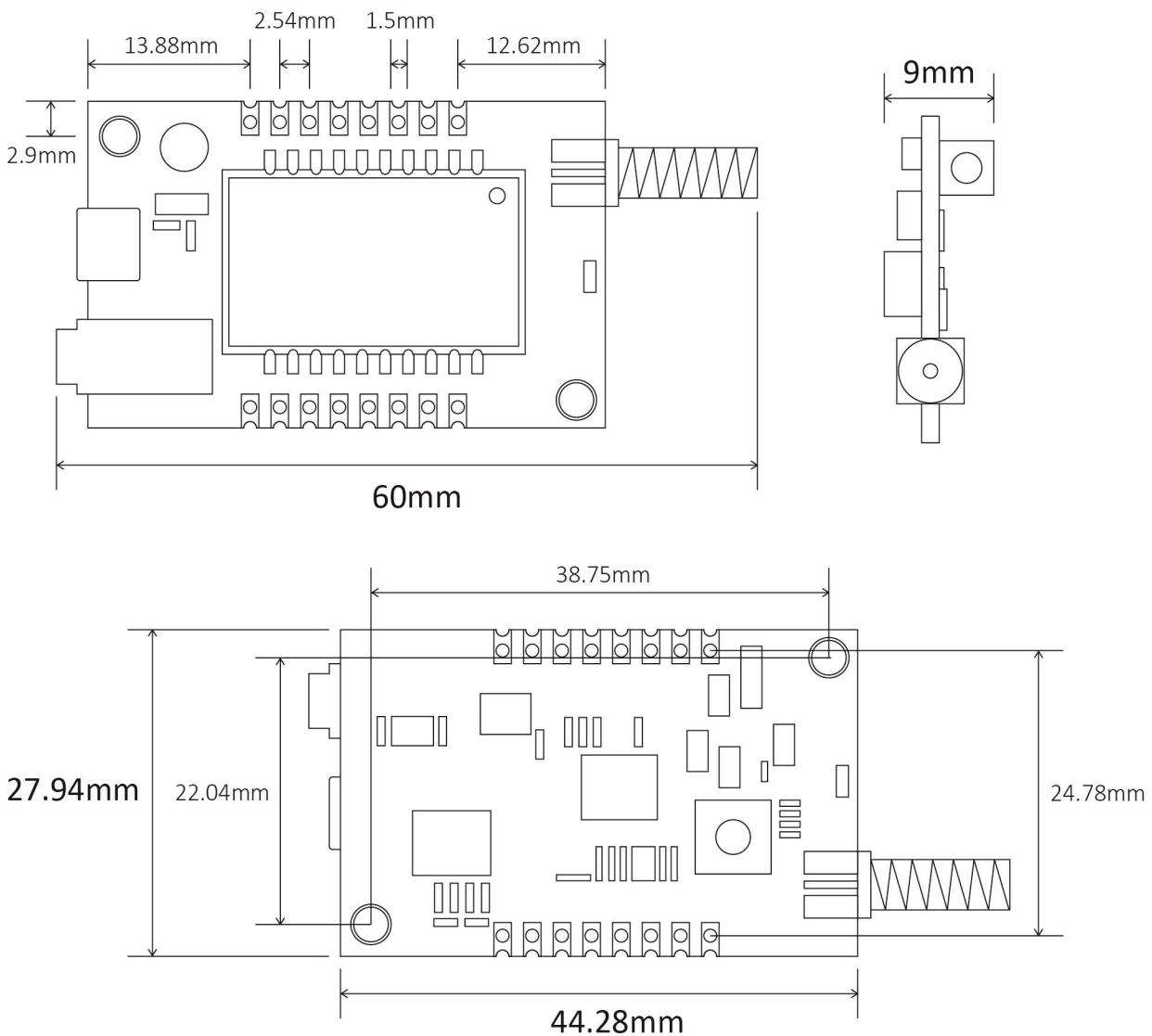

➤ SA326-RX

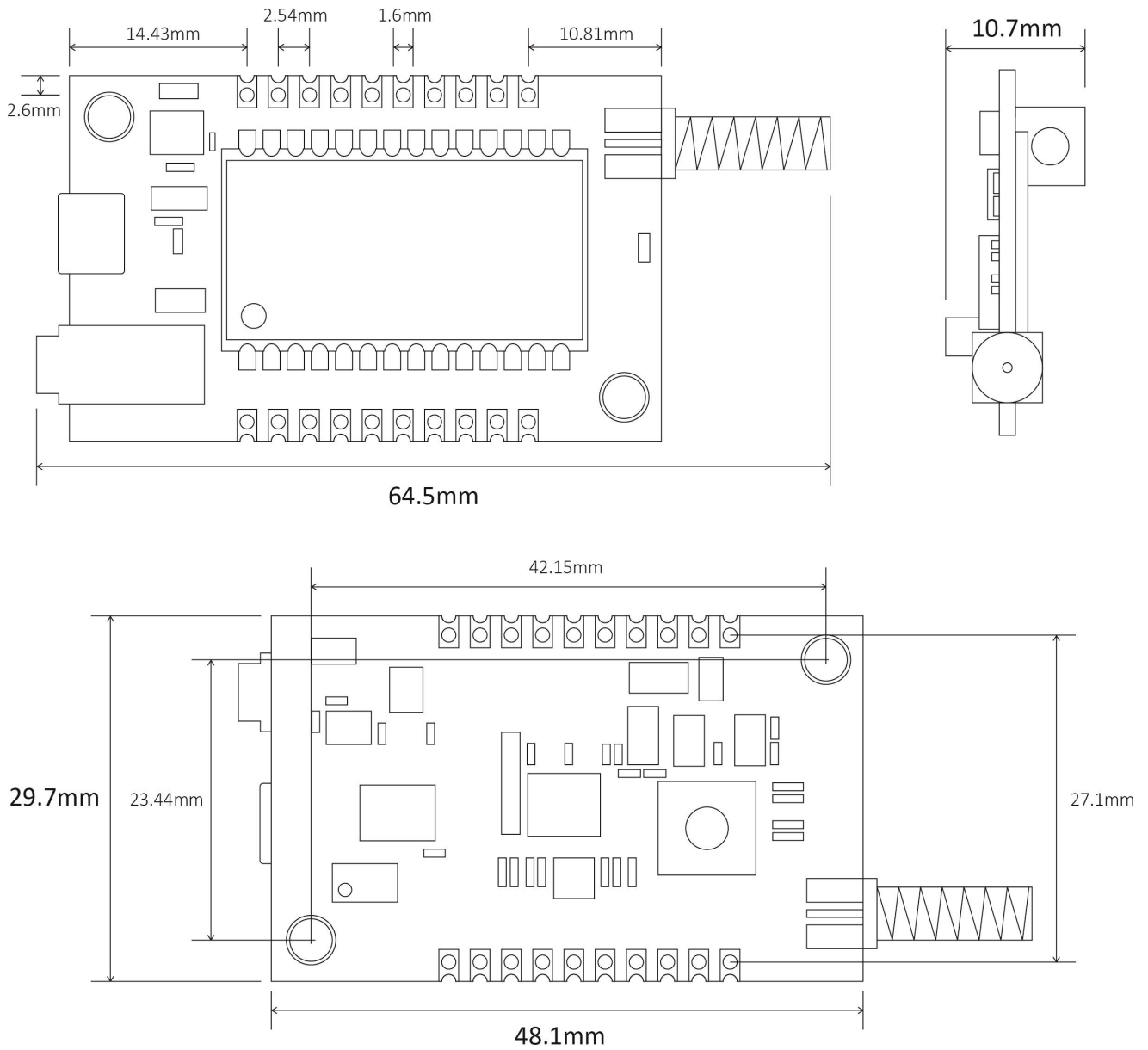

Appendix: Furnace temperature curve diagram

We recommend you should obey the IPC related standards in setting the reflow profile:

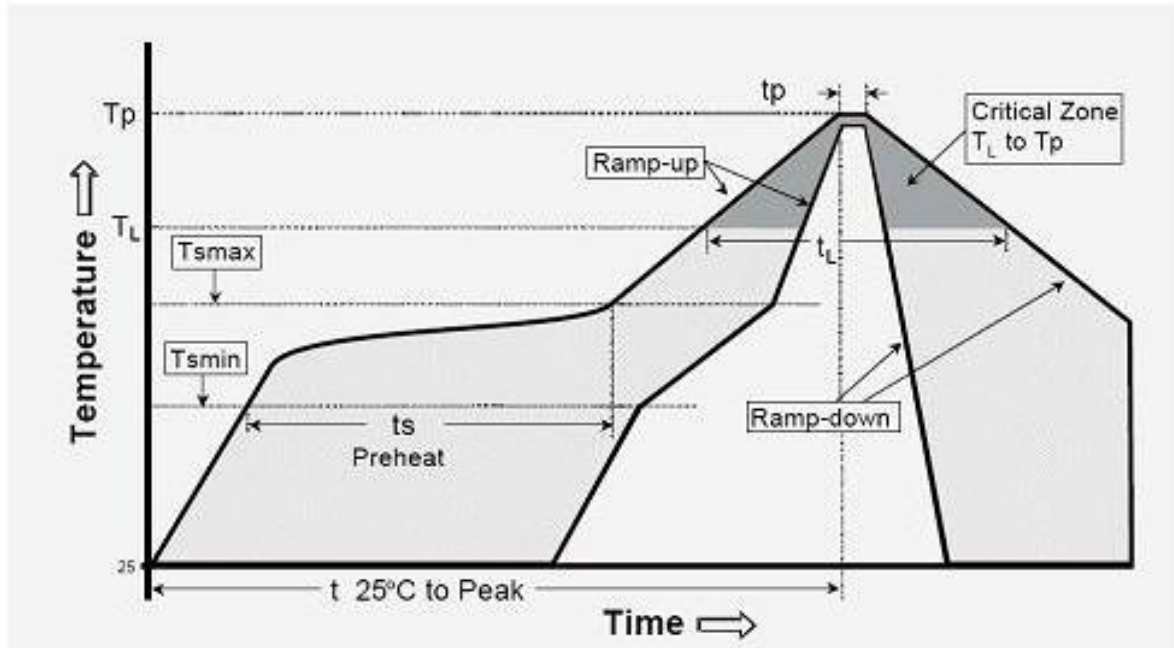

IPC/JEDEC J-STD-020B the condition for lead-free reflow soldering	big size components (thickness $\geq 2.5\text{mm}$)
The ramp-up rate (Tl to Tp)	3°C/s (max.)
preheat temperature	
- Temperature minimum (Tsmín)	150°C
- Temperature maximum (Tsmáx)	200°C
- preheat time (ts)	60~180s
Average ramp-up rate(Tsmáx to Tp)	3°C/s (Max.)
- Liquidous temperature(TL)	217°C
- Time at liquidous(tL)	60~150 second
peak temperature(Tp)	245+/-5°C

X-ON Electronics

Largest Supplier of Electrical and Electronic Components

Click to view similar products for [Audio Modules](#) category:

Click to view products by [G-NiceRF](#) manufacturer:

Other Similar products are found below :

[VC-01_CN](#) [VC-01-Kit_CN](#) [HLK-V20](#) [VC-02-Kit_CN](#) [VC_burner](#) [VC-02_CN](#) [DFR0954](#) [SA326-TX](#) [SA628F30-U](#) [SA618F22](#) [SA618F30-U](#)
[SA628F22](#) [SA316-RX](#) [SA326-RX](#) [SA316-TX](#) [OKY3153](#) [OKY3161](#) [OKY3136](#) [OKY3151-2](#) [OKY3156](#) [OKY3157](#) [SPEECH](#)
[RECOGNIZER V1.0](#) [GROVE SPEECH RECOGNIZER KIT FOR ARDUINO](#) [E393242100](#) [DFR0719](#) [DFR0718](#) [OKY3102](#) [AMP2X15](#)
[SEN0325](#) [SEN0487](#) [AT00-150016](#) [AT01-120016](#) [VC-01_EN](#) [VC-01-Kit_EN](#) [VC-02_EN](#) [WT516P6Core](#)