

2W Embedded small size walkie talkie module

Product Specification

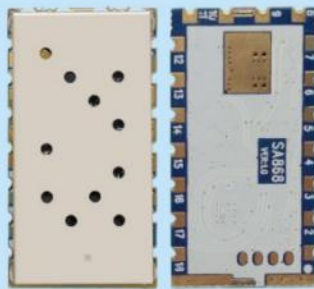

Catalogue

1. Descriptions.....	- 3 -
2. Features.....	- 3 -
3. Application.....	- 3 -
4. Internal block diagram.....	- 3 -
5. Specification.....	- 4 -
6. Typical Application Schematic.....	- 5 -
7. Communication protocol.....	- 5 -
8. Pin definition.....	- 9 -
8. Mechanism Dimension(Unit:mm).....	- 10 -
9. FAQ.....	- 10 -
Appendix 1: DEMO Board.....	- 11 -
Appendix 2: Mute on the interface display and send correspondence table.....	- 12 -
Appendix 3: Analog subtone comparison table.....	- 15 -
Appendix 4: SMD Reflow Chart.....	- 15 -

Note: Revision History

Revision	Date	Comment
V1.0	2018-11-22	First release
V1.1	2019-01-22	Modify parameters
V1.2	2020-11	Update description

1. Descriptions

SA868 is a cost-effective integrated professional walkie-talkie module, built-in high-speed microcontroller, high-performance RF transceiver chip and RF power amplifier, and provides a standard serial port to communicate with the module, so that the module's related parameters can be set quickly and easily. Function control. Users only need to connect an audio amplifier, microphone, and speaker to this module to work as a small walkie-talkie. The simplified interface and ultra-small size make this module widely available, and can be easily and quickly embedded in various handheld devices to improve the overall performance of the terminal products.

2. Features

- UHF band 400~480 MHz
- VHF band 134~174 MHz
- 350 band frequency: 320-400MHz
(3 frequency bands are optional)
- Transmit receive frequency independent
- Bandwidth 12.5 KHz
- RSSI signal strength indication
- Open distance is 5 kilometers
- High receiving sensitivity: -124 dBm
- Highly integrated small volume
- 166-level positive phase, inverted CDCSS digital sub-audio
- 8-level squelch
- 8-level adjustable volume
- High and low power options (1.6W/1.8W)
- Wide operating voltage 3.3-5.5 V
- 38-level CTCSS analog sub-audio code
- Stable with 1ppm TCXO crystal

3. Application

- Small walkie talkie
- Outdoor sports products
- Ignore the intercom system
- Audio monitoring system
- Building community security system

4. Internal block diagram

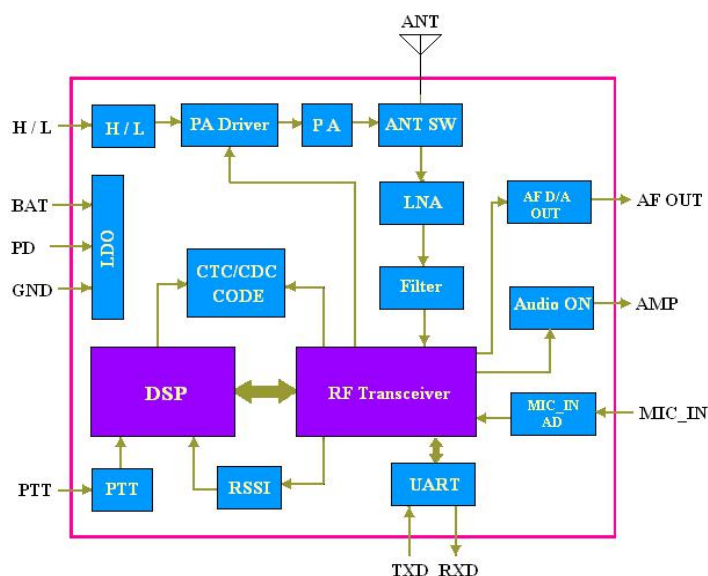

5. Specification

Parameter	Test condition	Min	Typ.	Max	Unit
Power supply		3.3	4.2	5.5	V
Working Temperature range		-30	25	70	°C
Current Consumption					
Sleep current			≤1		uA
RX current			60		mA
TX current (High power)			900	1000	mA
TX current (low power)			450	550	mA
Transmitting RF Parameters					
Frequency range	UHF	400		480	MHz
	VHF	134		174	MHz
Out power (high power)	@VCC=4.0V	31	32.5	33	dBm
Out power (low power)		24	25	26	dBm
Modulation frequency	@1.5KHz/2.5KHz Frequency offset		10		mV
Audio modulation distortion	@1.5KHz/2.5KHz Frequency offset		2	5	%
SignaltoNoiseRatio	@1.5KHz/2.5KHz Frequency offset	38	40	45	dB
adjacent-channel power	@12.5K offset		-60		dBc
CTCSS Modulation frequency		0.35	0.5	0.75	KHz
Modulation frequency	UHF	400		480	MHz
Receiving RF Parameters					
Receiving sensitivity	13dB Output voice signal ratio		-124		dBm
Receiving SNR	@1.5KHz Frequency offset	45	50		dB
Audio output amplitude			700		mV
Audio Output impedance			200		OHm

6. Typical Application Schematic

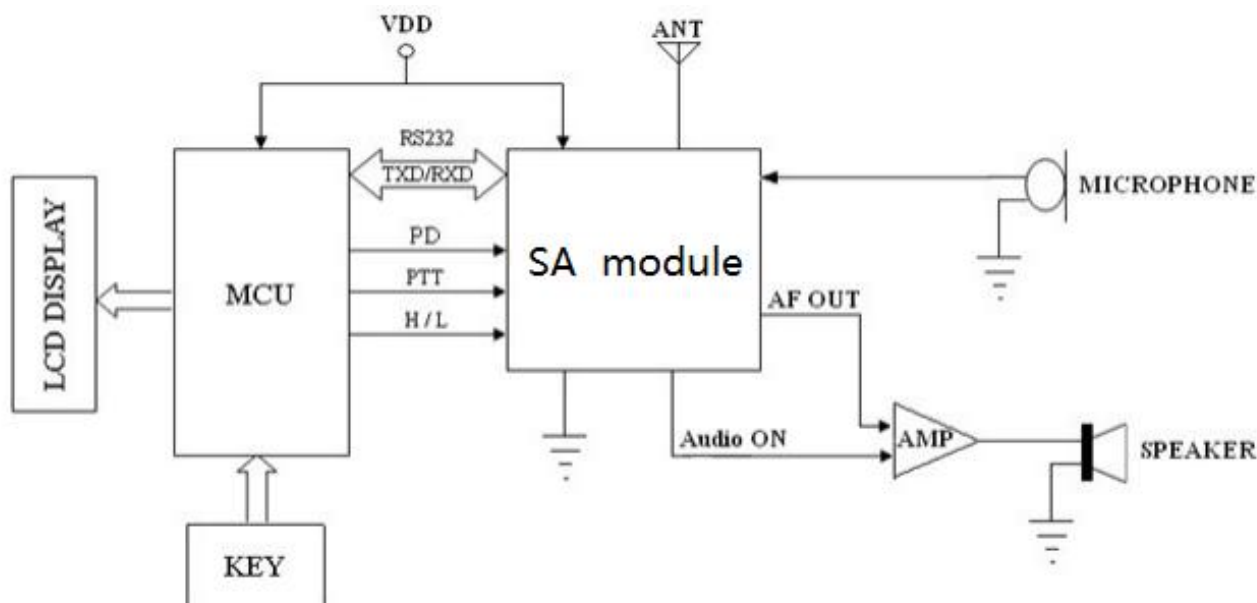

7. Communication protocol

The module provides a good user interface (standard serial port), the user can send commands through the serial port to adjust and read the module parameters. The memory is integrated inside the module, and the related parameters of the configuration can be stored.

Instruction transmission format:

All instructions start with "AT" and end with <CR><LF>.

After the module is running, the standard settings of the communication serial port are:

Rate: 9600 bps Data bits: 8 bits Stop bits: 1 bit Parity: None

➤ Instruction return format:

Returns a string associated with the send instruction, ending with <CR><LF>.

➤ Frame format definition:

All instructions in the communication protocol are transmitted in ASCII.

Terminal to module communication takes the form: AT+DMOXXX

The module adopts the form of terminal communication: +DMOXXX (Note: the terminal does not need to return)

Instruction description**➤ AT+DMOCONNECT Handshake instruction**

Description: The handshake instruction is intended to prove that the module is connected and operating normally. Each time the terminal sends it, the module returns after receiving this command. Repeat response command; if the 3 handshake command does not receive the module response, the terminal should restart the module.

Format: AT+DMOCONNECT

Example: AT+DMOCONNECT

➤ +DMOCONNECT Handshake response command

Description: The module handshake response command, the module must respond to the first time after receiving the DMOCONNECT command.

Format: +DMOCONNECT:0

Example: +DMOCONNECT:0

Parameter X description: 0 —> Normal working status

➤ S+Sweep command

Description: Set the frequency to scan.

Format: S+scanRF

Example: S+455.2250

Parameter description:

scanRF: the frequency to scan

➤ S=Sweep response command

Description: Sweep response command, the module will sweep the frequency after receiving the sweep command, sweep the frequency and return to the sweep result.

Format: S=X

Parameter description:

0—>The frequency to be scanned has a signal

1—>There is no signal to sweep the frequency

➤ **AT+DMOSETGROUP Set group instruction**

Description: Set the working parameters of the module.

Format: AT+DMOSETGROUP=GBW, TFV, RFV, Tx_CXCSS, SQ, Rx_CXCSS

Example 1: AT+DMOSETGROUP=0,415.1250,415.1250,0012,4,0013

Example 2: AT+DMOSETGROUP=0,415.1250,415.1250,754N,4,445I

Parameter Description:

GBW: Bandwidth setting (0: 12.5K 1: 25K)

TFV: Transmit frequency value (134.0000M~174.0000M,400.0000M~480.0000M)

RFV: Receiving frequency value (134.0000M~174.0000M,400.0000M~480.0000M)

(Note: The transmission frequency and reception frequency can be the same or different, but the set frequency must be 12.5K and 25K.Integer multiple)

Tx_CXCSS: TX CXCSS Value

SQ: Squelch level(0~8) (0: Monitor mode, scan mode cannot be used 0)

Rx_CXCSS: RX CXCSS Value

(Note: different CXCSS values can be used for transmission and reception, 0000: no coding 0001-0038: CTCSS After the letter: CDCSS, the code is shown in the attached table 1)

➤ **+DMOSETGROUP Set group response command**

Description: After receiving the setup group command, the module returns the operation result.

Format: +DMOSETGROUP:X

Example: +DMOSETGROUP:0

Parameter X description:0 → Success, 1 → Data setting is out of range

➤ **AT+DMOSETVOLUME Set the volume command**

Description: Set the volume level of the module

Format: AT+DMOSETVOLUME=X

Example: AT+DMOSETVOLUME=1

Parameter X description:The volume level parameter ranges from 1 to 8

➤ **+DMOSETVOLUME** Volume setting response command

Description: Set the module's volume level result response

Format: +DMOSETVOLUME:X

Example: +DMOSETVOLUME:0

Parameter X description: 0—>Set successfully 1—>Setup failed

➤ **AT+RSSI** Read signal strength command

Description: Read the signal strength of the module

Format: AT+RSSI? Example: AT+RSSI?

➤ **RSSI=XXX** Read signal strength response command

Description: Read module's signal strength result response

Format: RSSI:XXX

Format: RSSO:010

Parameter X description: Current signal strength value, the larger the value, the stronger the signal strength

➤ **AT+SETFILTER** Set filter instructions

Description: Set the filter of the module

Format: AT+SETFILTER=PRE/DE-EMPH,HIGHPASS,LOWPASS

Example: AT+SETFILTER=0,0,0

Parameter description : PRE/DE-EMPH,0 means pre-emphasis/de-emphasis on, and 1 means pre-emphasis/de-emphasis off;

HIGHPASS, 0 means the high-pass filter is on, and 1 means the high-pass filter is off;

LOWPASS, 0 means the low-pass filter is on, and 1 means the low-pass filter is off;

➤ **+DMOSETFILTER** Filter setting response command

Description: Set the module's filter result response

Format: +DMOSETFILTER:X

Example: +DMOSETFILTER:0

Parameter X description: 0—>Set successfully 1—>Setup failed

8. Pin definition

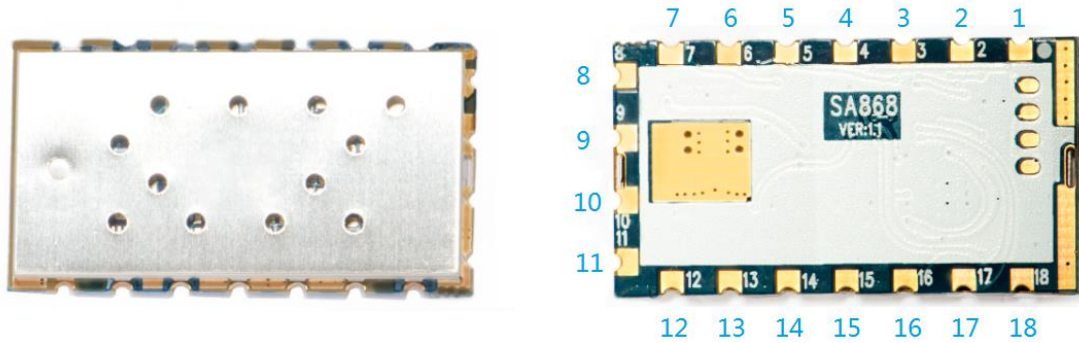

Pin NO.	Pin name	I/O state
1	Audio ON	Connected to audio power amplifier. When the module worked, it can control the extra audio amplifier automatically, it will output low level to turn on the amplifier and high level to turn off the amplifier.
2	NC	Not connected
3	AF_OUT	Audio output
4	NC	Not connected
5	PTT	Module Input, Transmitting/receiving control, "0" force the module to enter TX state; and "1" to Rx state
6	PD	Power Down control, "0" for power down mode; "1" for the normal work
7	H/L	high/low output power control; Leave open for high output power , low level to low output power. (Please kindly note: this pin can NOT be connected to VDD or high level of cmos output)
8	VBAT	Connect power positive
9	GND	Grounding
10	GND	Grounding
11	NC	Not connected
12	ANT	connect 50 ohm antenna
13,14,15	NC	Not connected
16	RXD	RXD of the module and connect to external TXD
17	TXD	TXD of the module and connect to external RXD
18	MIC_IN	Microphone or line in

8. Mechanism Dimension(Unit:mm)

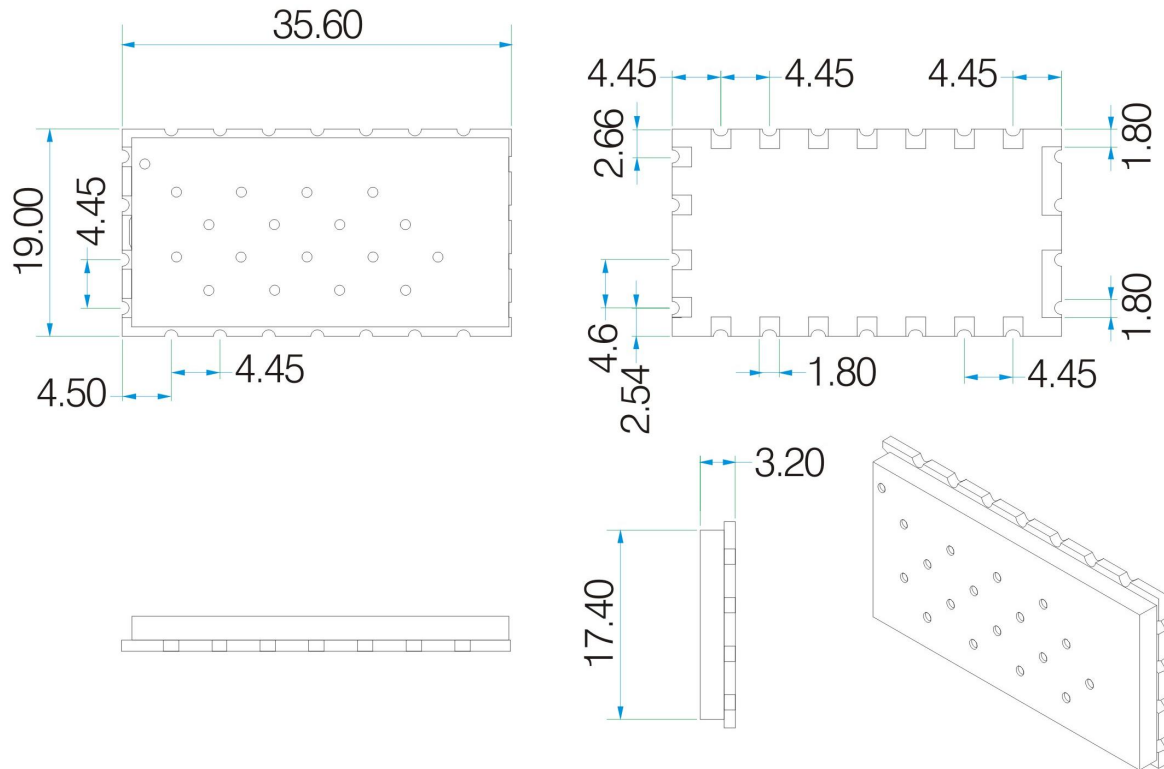

9. FAQ

- a) Why module can not communicate properly?
- 1) Check if there is power connection error;
 - 2) Check if Module is in normal communication mode;
 - 3) Check if frequency, channel, and mute are same;
 - 4) Check if module is damaged;
- b) Why transmission distance is not far as it should be?
- 1) Power supply ripple is too large;
 - 2) The antenna types do not match, or not installed properly;
 - 3) The same frequency interference;
 - 4) The surrounding environment is harsh, strong interference sources.

Appendix 1: DEMO Board

In addition, we provided DEMO Board for customers to debug the software program, test all the function and measure the distance. The figure shows as below:

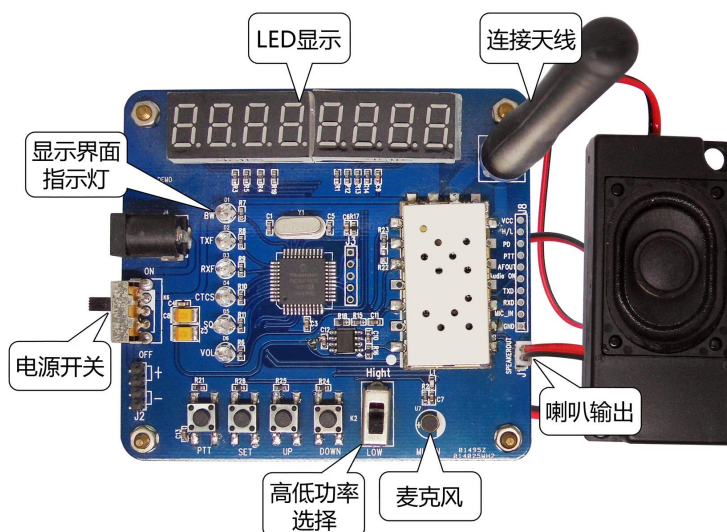

User can set related parameters through the buttons:

- 1) Tx frequency: 400 ~ 480 MHz
- 2) Rx frequency: 400 ~ 480 MHz
- 3) Channel Bandwidth: 12.5 KHz / 25KHz
- 4) CTCSS: 0 ~ 38
- 5) CDCSS: 0—166
- 6) Squelch: 0 ~ 8
- 7) Volume: 1 ~ 8

➤ Button Operation:

- 1) SET button

Press to enter setting mode.

- 2) UP /Down button

In setting mode, press to increase/decrease the setting item.

- 3) PTT button

If Not in setting mode, Press to talk,(Listen state when released)

- 4) High/Low slide switch

Switch to high/low output power

Note: With data FLASH inside, all the setting parameters are saved and keep unchanged even power off.

Appendix 2: Mute on the interface display and send correspondence table

★Note: The N code is encoded as the corresponding I code code bitwise inversion, such as 023N code is 023I code bitwise negation:

$$023N = \sim 023I = 00110111111000111001000$$

Code	Transform Bit Pattern	Hex Bit Pattern
023I	11001000000111000110111	640E37
025I	10101000000111101101011	540F6B
026I	01101000000110111010011	340DD3
031I	10011000000111111000101	4C0FC5
032I	01011000000110101111101	2C0D7D
043I	11000100000101101101101	620B6D
047I	11100100000110111111000	720DF8
051I	10010100000101010011111	4A0A9F
054I	00110100000100101111011	1A097B
065I	10101100000110001011101	560C5D
071I	10011100000110011110011	4E0CF3
072I	01011100000111001001011	2E0E4B
073I	11011100000101100111010	6E0B3A
074I	00111100000111100010111	1E0F17
114I	00110010000101111010110	190BD6
115I	10110010000111010100111	590EA7
116I	01110010000110000011111	390C1F
125I	10101010000111011110000	550EF0
131I	10011010000111001011110	4D0E5E
132I	01011010000110011100110	2D0CE6
134I	00111010000110110111010	1D0DBA
143I	11000110000101011110110	630AF6
152I	01010110000100110111100	2B09BC
155I	10110110000110110010001	5B0D91

156I	01110110000111100101001	3B0F29
162I	01001110000100111101011	2709EB
165I	10101110000110111000110	570DC6
172I	01011110000111111010000	2F0FD0
174I	00111110000111010001100	1F0E8C
205I	10100001000110010111011	508CBB
223I	11001001000101110001011	648B8B
226I	01101001000100001101111	34886F
243I	11000101000111011010001	628ED1
244I	00100101000101011111100	128AFC
245I	10100101000111110001101	528F8D
251I	10010101000111100100011	4A8F23
261I	10001101000111101110100	468F74
263I	11001101000100010111101	6688BD
265I	10101101000100111100001	5689E1
271I	10011101000100101001111	4E894F
306I	01100011000111110011000	318F98
311I	10010011000110110001110	498D8E
315I	10110011000101100011011	598B1B
331I	10011011000101111100010	4D8BE2
343I	11000111000111101001010	638F4A
346I	01100111000110010101110	338CAE
351I	10010111000111010111000	4B8EB8
364I	00101111000110100001011	178D0B
365I	10101111000100001111010	57887A
371I	10011111000100011010100	4F88D4
411I	10010000100101101110111	484B77
412I	01010000100100111001111	2849CF
413I	11010000100110010111110	684CBE
423I	11001000100110011101001	644CE9

431I	10011000100110100011011	4C4D1B
432I	01011000100111110100011	2C4FA3
445I	10100100100100011101111	5248EF
464I	00101100100101111110010	164BF2
465I	10101100100111010000011	564E83
466I	01101100100110000111011	364C3B
503I	11000010100101100011110	614B1E
506I	01100010100100011111010	3148FA
516I	01110010100111011000001	394EC1
532I	01011010100111000111000	2D4E38
546I	01100110100101111001100	334BCC
565I	10101110100111100011000	574F18
606I	01100001100110011011101	30CCDD
612I	01010001100110001110011	28CC73
624I	00101001100110101111000	14CD78
627I	11101001100111111000000	74CFC0
631I	10011001100100010100111	4CC8A7
632I	01011001100101000011111	2CCA1F
654I	00110101100111000011001	1ACE19
662I	01001101100111100010010	26CF12
664I	00101101100111001001110	16CE4E
703I	11000011100111010100010	61CEA2
712I	01010011100110111101000	29CDE8
723I	11001011100100011001110	65C8CE
731I	10011011100100100111100	4DC93C
732I	01011011100101110000100	2DCB84
734I	00111011100101011011000	1DCAD8
743I	11000111100110110010100	63CD94
754I	00110111100111110000010	1BCF82

Appendix 3: Analog subtone comparison table

Subtone coding	1	2	3	4	5	6	7	8	9	10
Sub-audio frequency	67	71.9	74.4	77	79.7	82.5	85.4	88.5	91.5	94.8
Subtone coding	11	12	13	14	15	16	17	18	19	20
Sub-audio frequency	97.4	100	103.5	107.2	110.9	114.8	118.8	123	127.3	131.8
Subtone coding	21	22	23	24	25	26	27	28	29	30
Sub-audio frequency	136.5	141.3	146.2	151.4	156.7	162.2	167.9	173.8	179.9	186.2
Subtone coding	31	32	33	34	35	36	37	38		
Sub-audio frequency	192.8	203.5	210.7	218.1	225.7	233.6	241.8	250.3		

Appendix 4: SMD Reflow Chart

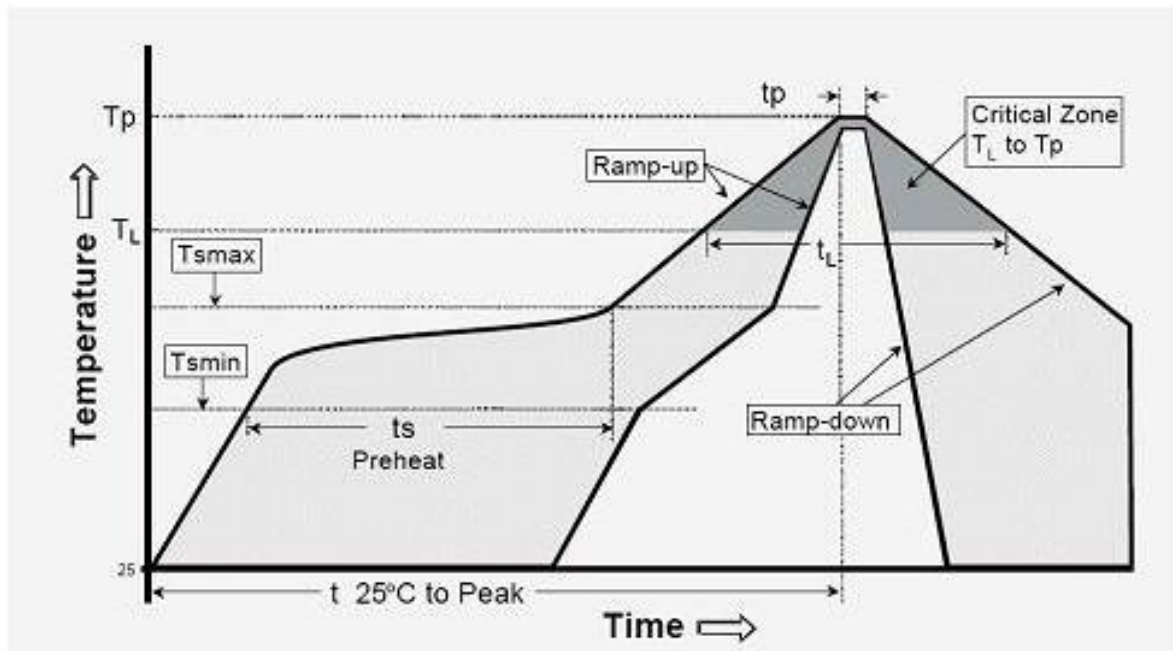

IPC/JEDEC J-STD-020B the condition for lead-free reflow soldering	big size components (thickness $\geq 2.5\text{mm}$)
The ramp-up rate (Tl to Tp)	3°C/s (max.)
preheat temperature	
- Temperature minimum (T _{min})	150°C
- Temperature maximum (T _{max})	200°C
- preheat time (t _s)	60~180s
Average ramp-up rate(T _{max} to Tp)	3°C/s (Max.)
- Liquidous temperature(T _L)	217°C
- Time at liquidous(t _L)	60~150 second
peak temperature(T _p)	245+/-5°C

X-ON Electronics

Largest Supplier of Electrical and Electronic Components

Click to view similar products for [GPS Modules](#) category:

Click to view products by [G-NiceRF](#) manufacturer:

Other Similar products are found below :

[333-1505-L300](#) [YW02-CM01](#) [PCB \(\)](#) [Barcode Scanner Module](#) [RC1882HP-RIIM-DK](#) [T110-3](#) [T150-4](#) [SA868-U](#) [SA818S-U](#) [SA828-U](#)
[SA828-V](#) [SL871GPS232R001](#) [DD-14239](#) [M20050-1](#) [M20048-1](#) [WISE-4610P-NA](#) [M10578-A2](#) [M10578-A3](#) [CMM21T-900M-N](#) [TEL0132](#)
[DPX252690DT-5031G1](#) [PKG300060P](#) [ISM3333-C6.1](#) [RXM-GPS-F4-T](#) [A1084-A](#) [MIKROE-4150](#) [28504](#) [L26ADR-S89](#) [L26-M33](#) [L26T-](#)
[S89](#) [L70B-M39](#) [L76L-M33](#) [L86-M33](#) [L89-S90](#) [L96-M33](#) [SIM68M](#) [GPS-13670](#) [GPS-19166](#) [SPX-18019](#) [TESEO-LIV3F](#) [TESEO-LIV3R](#)
[TESEO-VIC3DA](#) [SWI0805UF-R68J](#) [GYSFFMAXB](#) [GYSFFMAXC](#) [DPX105950DT-6112A1](#) [TFSC062495-6110A2](#) [EVA-M8Q-0](#)
[2613011037000](#)