

High Precision & Low Power Satellite navigation system  
GPS & BeiDou & GLONASS module

## Product Specification

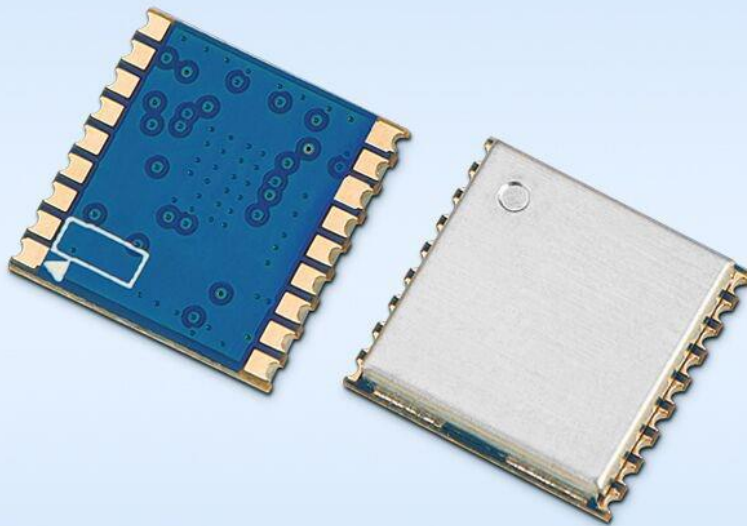

## Catalogue

1. Overview.....	- 3 -
2. Features.....	- 3 -
3. Applications .....	- 3 -
4. Typical application circuit .....	- 4 -
5. Module interface description .....	- 4 -
6. Performance parameters .....	- 5 -
7. Typical application circuit .....	- 6 -
8. Pin definition.....	- 7 -
9. Recommended antenna index .....	- 8 -
10. Mechanical size (unit : mm) .....	- 9 -
11. Recommended package .....	- 10 -

### Note: Revision History

Revision	Date	Comment
V1.0	2020-8	First release

## 1. Overview

SW-GPS01 module is a positioning module that supports BDS B1/GPS L1/GLONASS L1 frequency point (two out of three) dual-mode navigation. It provides high sensitivity, high positioning accuracy, low power consumption and low cost positioning and navigation solutions for the manufacture of navigation and positioning terminal products such as vehicle, shipborne, handheld and wearable.

## 2. Features

- Support BDS B1/GPS L1/GLONASS L1 frequency point
- Support hot start
- With backup power input interface
- Support external reset
- The following six working modes are supported, and they can be switched through commands:
  - 1 ) Single BDS B1 working mode
  - 2 ) Single GPS L1 working mode
  - 3 ) Single GLONASS L1 working mode
  - 4 ) BDS B1/GPS L1 dual-mode working mode (default mode)
  - 5 ) GLONASS L1/BDS B1 dual-mode working mode
  - 6 ) GLONASS L1/GPS L1 dual mode working mode

## 3. Applications

- Personal positioning and navigation products
- Internet of Things
- Vehicle, ship positioning and navigation
- Handheld portable device

## 4. Typical application circuit

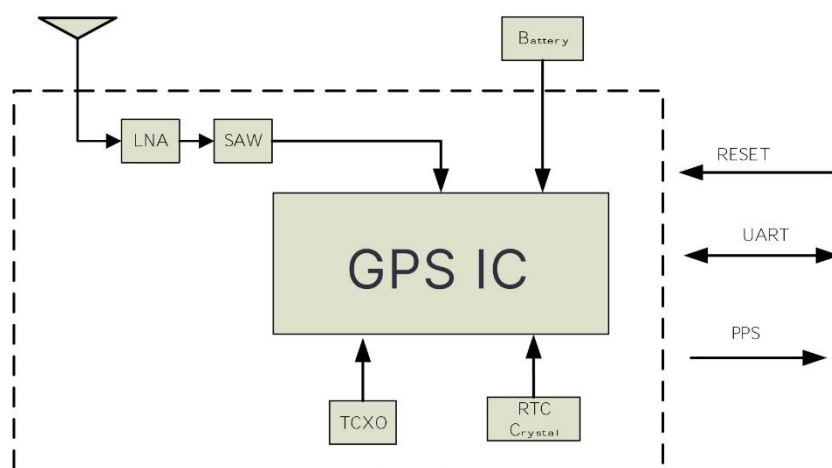

## 5. Module interface description

### 1) Power supply

The module has three power input pins (VCC, V\_BCKP and VDD\_IO) and one power output pin (VCC\_RF).

VCC is the main power supply of the module.

VCC\_IO is the IO power supply of the module.

V\_BCKP is the backup input power supply of the module, which supplies power to the RTC circuit when the main power supply VCC is cut off to ensure that key information is not lost, so as to realize the hot start function.

VCC\_RF outputs 3.3V voltage value, which can be used to power the antenna or the external LNA of the module.

### 2) Antenna interface

The antenna interface (RF\_IN pin) of the module can be directly connected to a multi-mode antenna. The interface adopts 50Ω impedance matching inside.

### 3) Reset interface

The module has its own power-on reset circuit. If the user does not use the external reset function of the module, the nRESET pin can be left floating; if the user uses the external reset function, the module can be reset after the VCC voltage stabilizes for 50ms. Keep for more than 1ms, the timing is as follows:

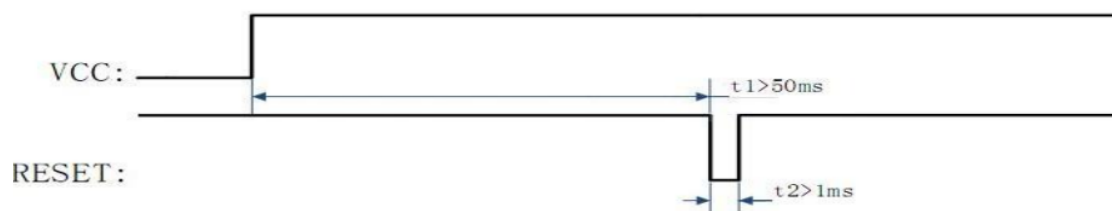

#### 4) 1PPS signal interface

Module 4 pin 1PPS is the second pulse signal output, 1PPS signal needs to be delayed for several seconds after the module realizes positioning.

#### 5) UART interface

The serial port outputs NMEA data at the UTC second boundary, and the host computer can also switch the module's working mode and baud rate through the serial port. The baud rate range supported by the module is 4800bps ~ 230400bps. The default baud rate is 9600bps.

The data format is: 1 start bit, 8 data bits, 1 stop bit, no parity bit.

### 6. Performance parameters

Parameter	Description	Minimum	Typical	Maximum	Unit	Condition
Operating conditions						
Operating voltage range	VCC	3.0	3.3	3.5	V	
	V_BCKP	2.5	3.3	3.5	V	
Temperature	Work	-40		85	°C	
	Storage	-40		125	°C	
Current consumption						
Receive current			< 30		mA	VCC=3.3V, V_BCKP=3.3V
Sleep current			< 20		uA	VCC=0V, V_BCKP=3.3V
Radio frequency parameters						
Positioning accuracy	Level		< 3		m	@Open land
	Elevation		< 4.5		m	

Sensitivity	capture		-147		dBm	
	track		-163		dBm	
External antenna gain				30	dB	
Speed measurement accuracy			< 0.1		m/s	
First fix time TTF	Cold start		< 28		s	
	Hot Start		1		s	
	Recapture		1		s	
Serial port parameters						
Serial port baud rate		4800	9600	230400	bps	Default 9600bps
Data update rate	Single mode			10	Hz	Default 1 Hz
	Dual mode		1	5		

**7. Typical application circuit**

- The active antenna connection method is as follows:

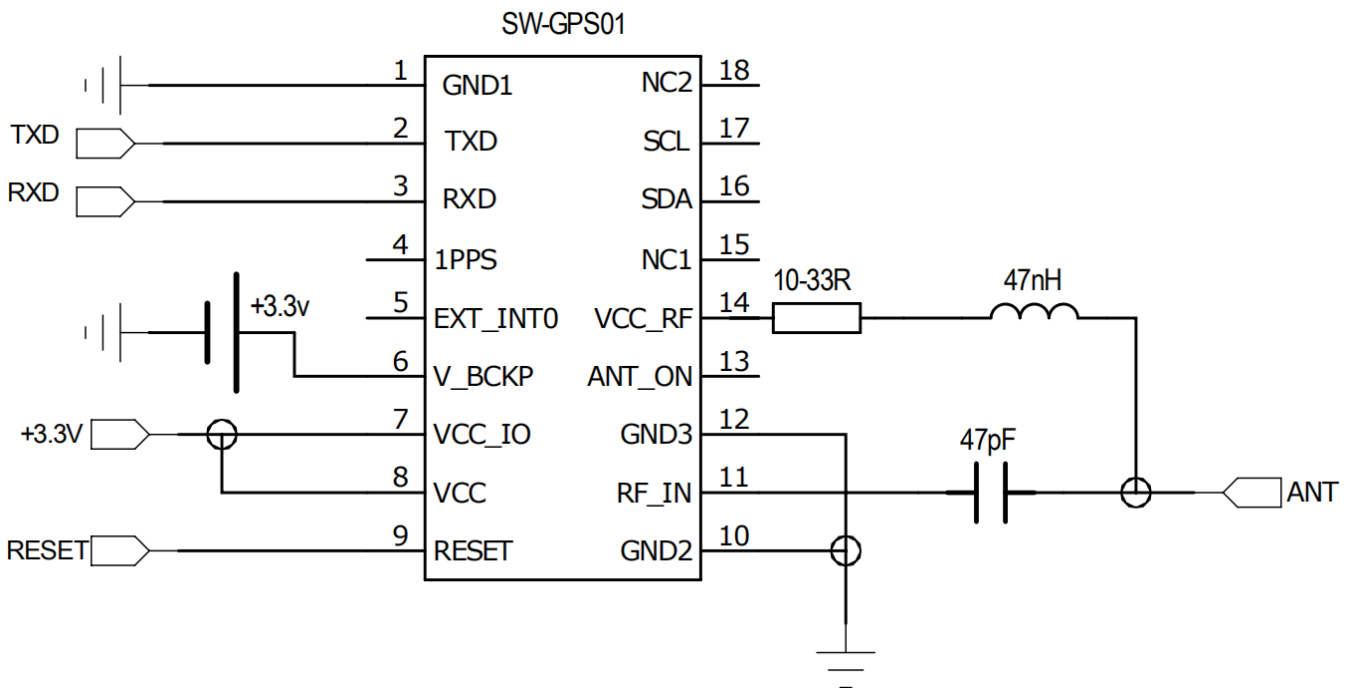

- The passive antenna connection method is as follows:

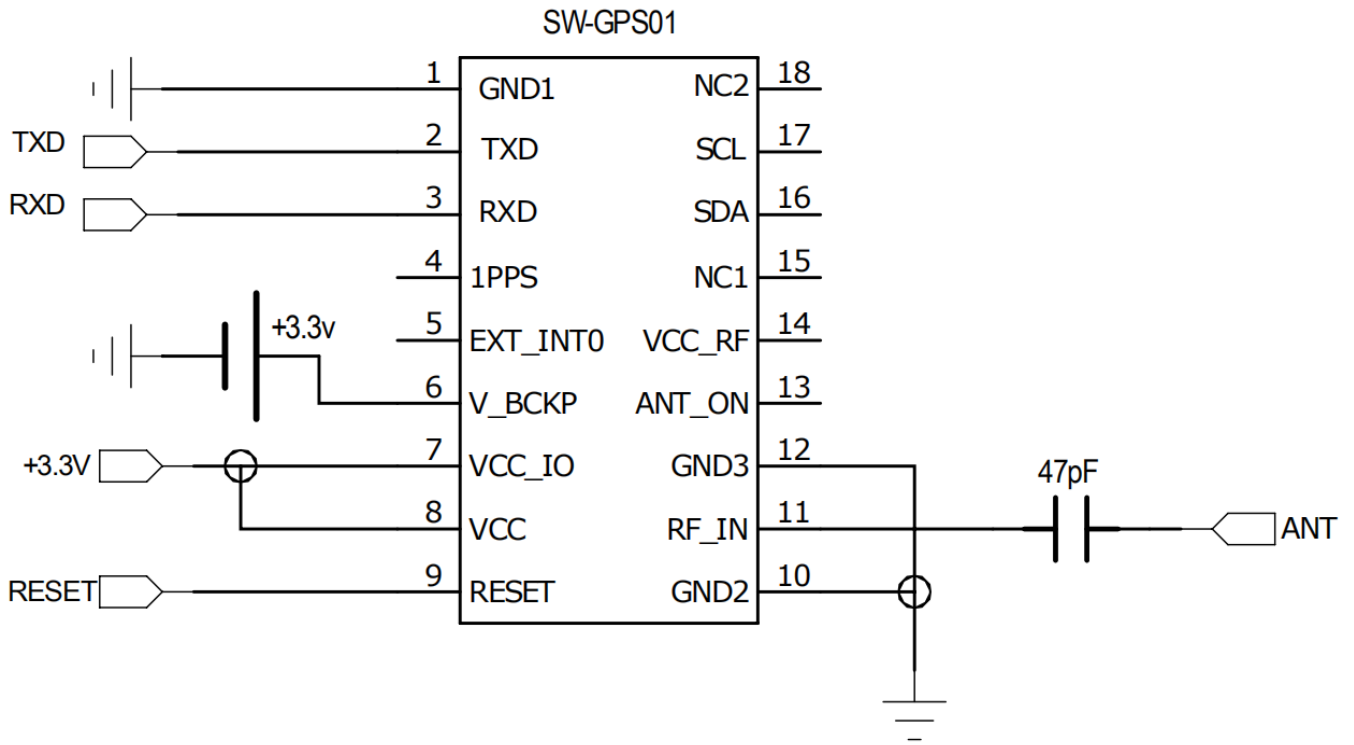

### 8. Pin definition

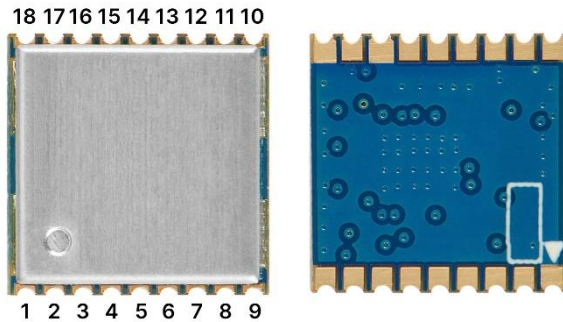

Pin number	Pin definition	I/O	Level standard	Description
1、10、12	GND	—		Power ground
2	TXD	O	0-3.5 V	Data output, status output
3	RXD	I	0-3.5 V	Control command reception
4	1PPS	O	0-3.5 V	Second pulse output
5	EXT_INT0	I	0-3.5 V	reserved port
6	V_BCKP	I	2.5-3.5 V	Backup power input

7	VCC_IO	—	3.0-3.5 V	IO power input
8	VCC	—	3.0-3.5 V	Main power input
9	nRESET	I	0-3.5 V	External reset, active low. The reset pin can not be connected to the ground capacitor outside the module.
11	RF_IN	I		Antenna input
13	ANT_ON	O	0-3.5 V	Built-in IC GPIO, function reserved
14	VCC_RF	O	VCC	3.3V output, the antenna is powered by the module, and the antenna working current is recommended not to exceed 20mA
15、 18	NC	—		
16	SDA	I/O	0-3.5 V	Data signal of two-wire DDC interface
17	SCL	I	0-3.5 V	Clock signal of two-wire DDC interface

## 9. Recommended antenna index

Item		Active antenna	Passive antenna
Frequency Range	BDS	1561.098 ± 2.046 MHz	1561.098 ± 2.046 MHz
	GPS	1575.42 ± 1.023 MHz	1575.42 ± 1.023 MHz
	GLONASS	1602.0 ± 4 MHz	1602.0 ± 4 MHz
input resistance		50Ω	50Ω
Gain		<30dB	-
In-band gain flatness		≤1.5dB	-
Noise Figure		≤1.5dB	-



Input standing wave	$\leq 1.5$	$\leq 1.5$
Output standing wave	$\leq 2$	$\leq 2$
Out-of-band rejection: 1568 $\pm$ 30MHz	$\leq 30\text{dB}$	-
Recommended working voltage	3.0V $\pm$ 0.3	-
temperature range	-40~85°C	-40~85°C

**10. Mechanical size (unit: mm)**

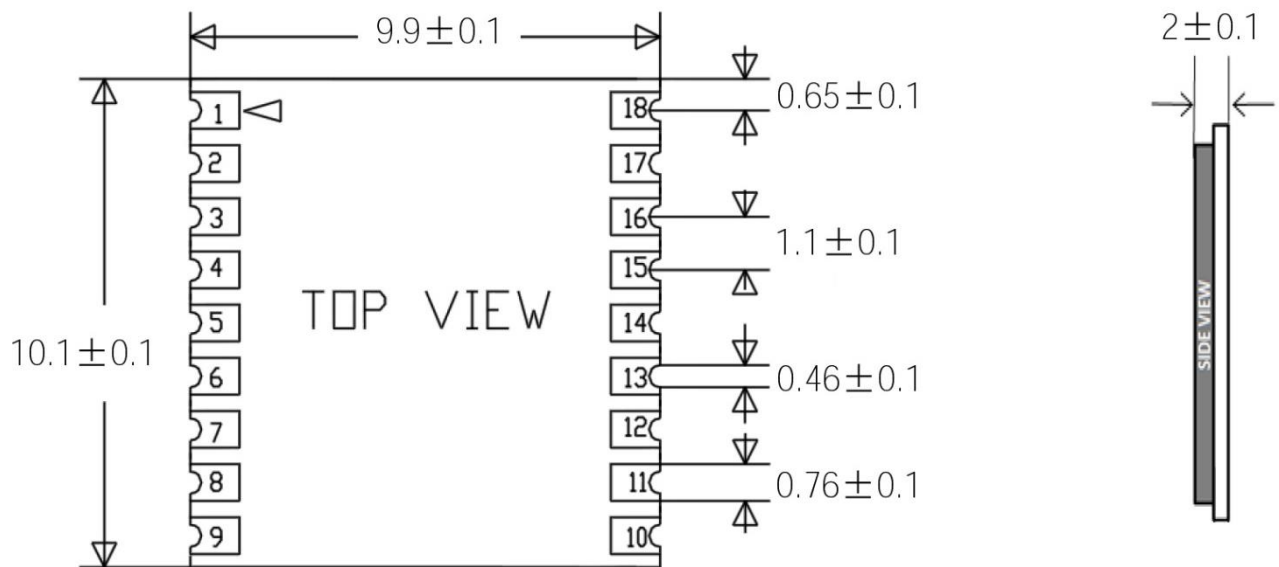

## 11. Recommended package

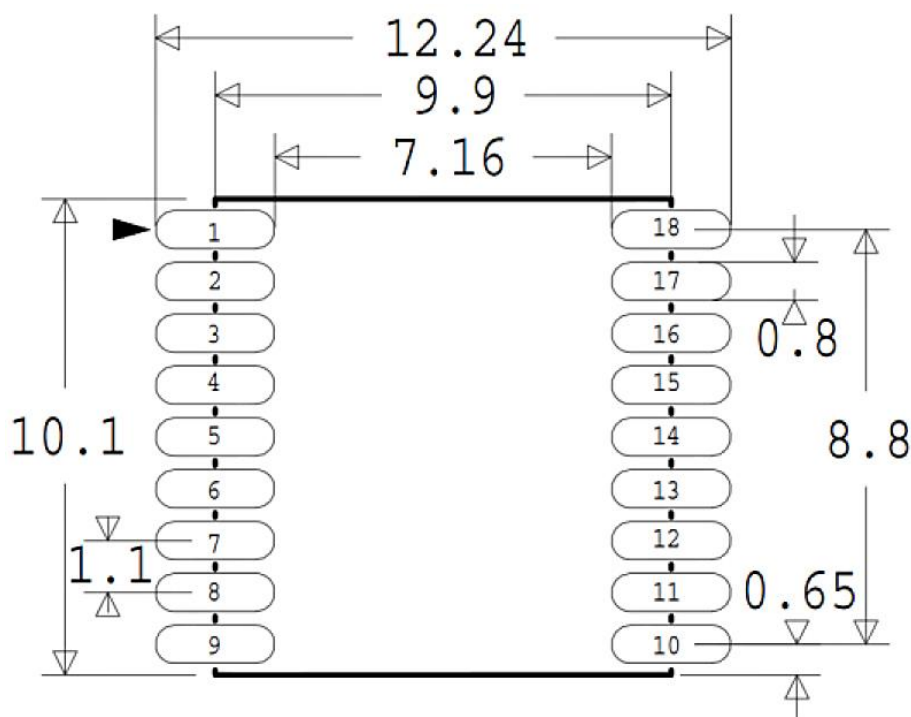

### ➤ Precautions :

- 1) The radio frequency circuit on the module contains electrostatic sensitive components. Please pay attention to electrostatic protection during soldering, installation and transportation. Please do not touch the RF\_IN pin with bare hands, otherwise the module may be damaged.
- 2) In product application, the transmission line connected to the RF\_IN terminal should be controlled with 50Ω impedance. Do not run at right angles or sharp angles, and try not to replace the signal layer. The adjacent layer below the connection line should have a complete ground plane. If the design is limited, at least ensure that the area corresponding to the label area has a complete ground plane. If there are other strong interference sources on the board, it is recommended to add a shield to the interference source. If the interference source frequency is close to the navigation signal frequency of the module, it is recommended to install a SAW filter at the front end of the module RF\_IN.
- 3) Try to control the module's VCC power supply ripple within 100mV, and avoid interference on the power supply.

- 4) Please ensure that the baud rate set by the host computer and the module is consistent.
- 5) It is recommended to select an active antenna with quality guaranteed BDS B1/GPS L1/GLONASS L1 frequency point (the user can select the corresponding frequency point antenna according to the working mode), and ensure that the antenna is powered.
- 6) Please control the temperature and operation method when soldering the module to avoid damage to the module.

## Appendix: Furnace temperature graph

We recommend you should obey the IPC related standards in setting the reflow profile:

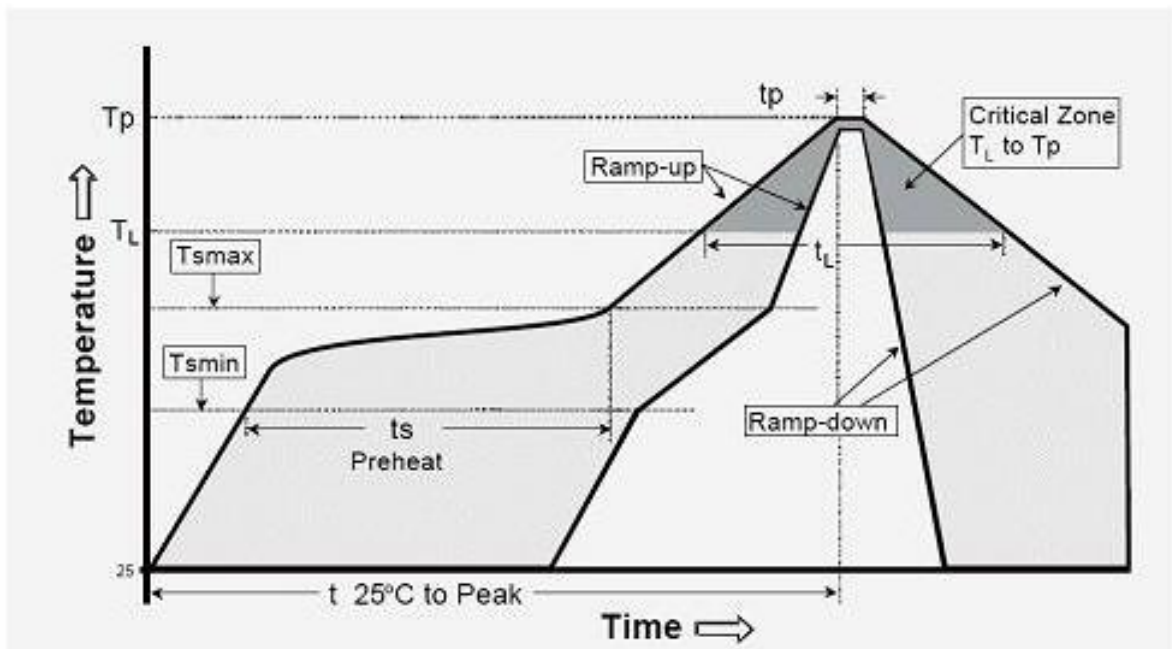

IPC/JEDEC J-STD-020B the condition for lead-free reflow soldering	big size components (thickness $\geq 2.5\text{mm}$ )
The ramp-up rate (Tl to Tp)	3°C/s (max. )
preheat temperature	
- Temperature minimum (T <sub>min</sub> )	150°C
- Temperature maximum (T <sub>max</sub> )	200°C
- preheat time (t <sub>s</sub> )	60~180s
Average ramp-up rate(T <sub>max</sub> to Tp)	3°C/s (Max. )
- Liquidous temperature(T <sub>L</sub> )	217°C
- Time at liquidous(t <sub>L</sub> )	60~150 second
peak temperature(T <sub>p</sub> )	245+/-5°C

## X-ON Electronics

Largest Supplier of Electrical and Electronic Components

*Click to view similar products for G-NiceRF manufacturer:*

Other Similar products are found below :

[lora1268F30-433](#) [STX883PRO-433MHz](#) [SA326-RX](#) [LORA6100II-470MHz](#) [LORA1280-TCXO](#) [lora1278F30-433](#) [SV610-915MHz](#)  
[lora610PRO-470MHz](#) [SV610-868MHz](#) [SV610-470MHz](#) [SA326-TX](#) [SA316-TX](#) [BLE5201](#) [lora1268F30-mini-433](#) [LORA-CC68-C1-433MHz](#)  
[RF4463PRO-868MHz](#) [LORA1262-915TCXO](#) [LORA610II-915MHz](#) [UWB3000F27](#) [LORA610II-470MHz](#) [lora1278F30-868](#) [lora1278-C1-](#)  
[470MHz](#) [RF4463F30-915](#) [RF4463PRO-470MHz](#) [LORA6100II-868MHz](#) [lora610PRO-433MHz](#) [lora1278F30-490](#) [SV610-433MHz](#) [SW-](#)  
[GPS01](#) [LORA-CC68-915MHz-TCXO](#) [LORA-CC68-X1-433MHz](#) [SA828-V](#) [GPS01-ZK](#) [UWB3000F00](#) [lora610PRO-868MHz](#) [SA868-U](#)  
[SA628F22](#) [lora1278F30-915](#) [LORA-CC68-C1-915MHz](#) [LORA-CC68-C1-868MHz](#) [LORA-CC68-470MHz-TCXO](#) [LORA-CC68-C1-470MHz](#)  
[LORA610II-868MHz](#) [LORA1262-868TCXO](#) [lora610PRO-915MHz](#) [LORA-CC68-433MHz-TCXO](#) [LORA610II-433MHz](#) [SA628F30-U](#)  
[SA618F22](#) [SA618F30-U](#)