

◆ General Description

GH1543A is a unipolar switched hall effect sensor IC, Which is for contactless switching applications. The small SOT-89 surface-mount style package, uses a industry standard "gull-wing" design which makes it less susceptible to "solder bridging" and allows increased circuit board density. The device includes an on-chip Hall voltage generator for magnetic sensing, an amplifier that amplifies the Hall voltage, a Schmitt trigger to provide switching hysteresis for noise rejection, and an open-collector output. GH1543A is designed to provide predictable performance over the full temperature range of -40 to +150°C and On-chip regulator provides extremely stable operation over the full supply voltage range of 3.8 to 30 VDC. GH1543A is capable of continuous 25mA sinking output current and may be cycled as high as 50mA maximum, It can use existing power supply sources in most applications, and can be directly interfaced with many electronic components without buffering or compensation circuitry.

◆ Features

- Wide temperature and voltage ranges for design flexibility and harsh (automotive) environments.
- Temperature compensated for consistent operation with low-cost magnets
- Industry standard "gull-wing" design. Less susceptibility to "solder bridging". Allows increased circuit board density.

◆ Applications

- Brushless DC motors
- Digital current sensor
- Anti-skid braking sensor
- Piston detection in hydraulic cylinder
- Valve position sensing
- Cam, lever, shaft position sensing
- Tachometer, counter pickup
- Push-button sensor
- Disk speed, tape rotation, flow rate sensing
- Speed sensing - rate, under,over speed
- Remote reading sensor
- Magnetic card reader

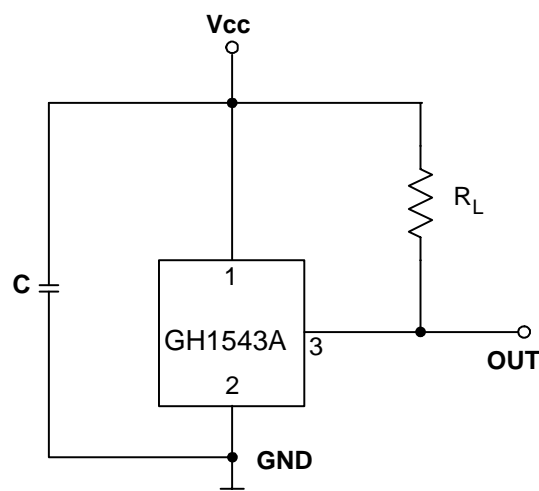

Figure.1 Typical Application of GH1543A

◆ Pin Configuration



Figure 2. Pin Configuration of GH1543A (Front View)

◆ Pin Description

Pin Number	Pin Name	Function
1	V _{CC}	IC Power Supply voltage
2	GND	IC Ground
3	OUT	Output

◆ Functional Block Diagram

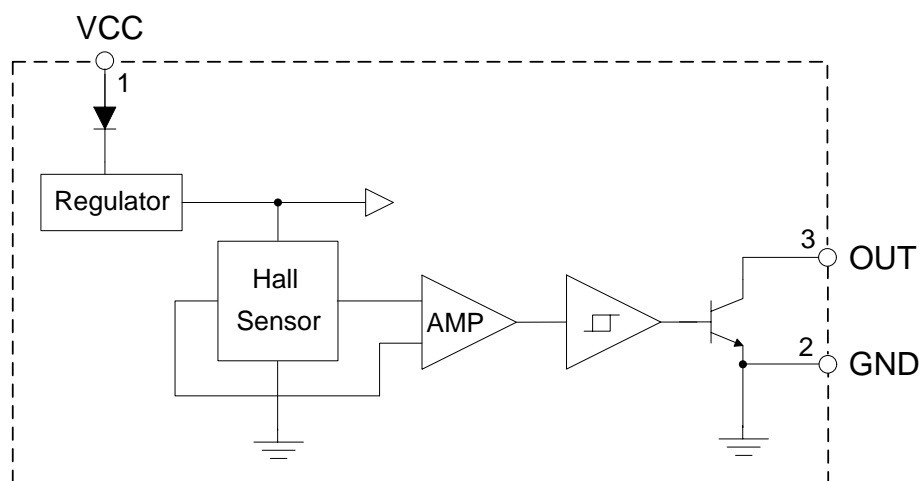

Figure 3. Functional Block Diagram of GH1543A

◆ **Absolute Maximum Ratings (Note 1)** ($T_A=25^{\circ}\text{C}$)

Parameter	Symbol	Value	Unit
Supply Voltage	V_{CC}	-20~+40	V
Output Current	I_O	50	mA
Power Dissipation	P_D	500	mW
Operating Temperature	T_A	-40 to 150	$^{\circ}\text{C}$
Storage Temperature Range	T_{STG}	-65 to 150	$^{\circ}\text{C}$
Magnetic Flux	B	Unlimited	Gauss

Note 1: Stresses greater than those listed under "Absolute Maximum Ratings" may cause permanent damage to the device. These are stress ratings only, and functional operation of the device at these or any other conditions beyond those indicated under "Recommended Operating Conditions" is not implied. Exposure to "Absolute Maximum Ratings" for extended periods may affect device reliability.

◆ **Recommended Operating Conditions** ($T_A=25^{\circ}\text{C}$)

Parameter	Symbol	Min	Max	Unit
Supply Voltage	V_{CC}	3.8	30	V
Ambient Temperature	T_A	-40	150	$^{\circ}\text{C}$

◆ **Electrical Characteristics** ($V_{CC}=12\text{V}, T_A=25^{\circ}\text{C}$, unless otherwise specified.)

Parameter	Symbol	Conditions	Min	Typ	Max	Unit
Supply Voltage	V_{CC}		3.8		30	V
Supply Current	I_{CC}	$V_{CC}=3.8\text{V to }30\text{V}$		4	10	mA
Output Leakage Current	I_{OL}	$V_{CE}=30\text{V}$		0.1	10	μA
Output Saturation Voltage	V_{SAT}	$I_{OUT}=25\text{mA}$		150	400	mV
Rise Time	t_r	$R_L=820\Omega$ $C_L=20\text{pF}$			1.5	μs
Fall Time	t_f	$R_L=820\Omega$ $C_L=20\text{pF}$			1.5	μs

◆ **Magnetic Characteristics** ($V_{CC}=12\text{V}, T_A=25^{\circ}\text{C}$, unless otherwise specified.)

Parameter	Symbol	Min	Typ	Max	Unit
Operating Point	B_{OP}	90		210	Gauss
Releasing Point	B_{RP}	60		170	Gauss
Hysteresis	B_{HYS}	25	50	75	Gauss

◆ Marking Information

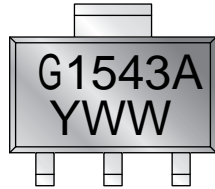

Y :Year,"1"=2011

WW: Nth Week,01~52

◆ Package Information

SOT-89 (Front View) (unit:mm)

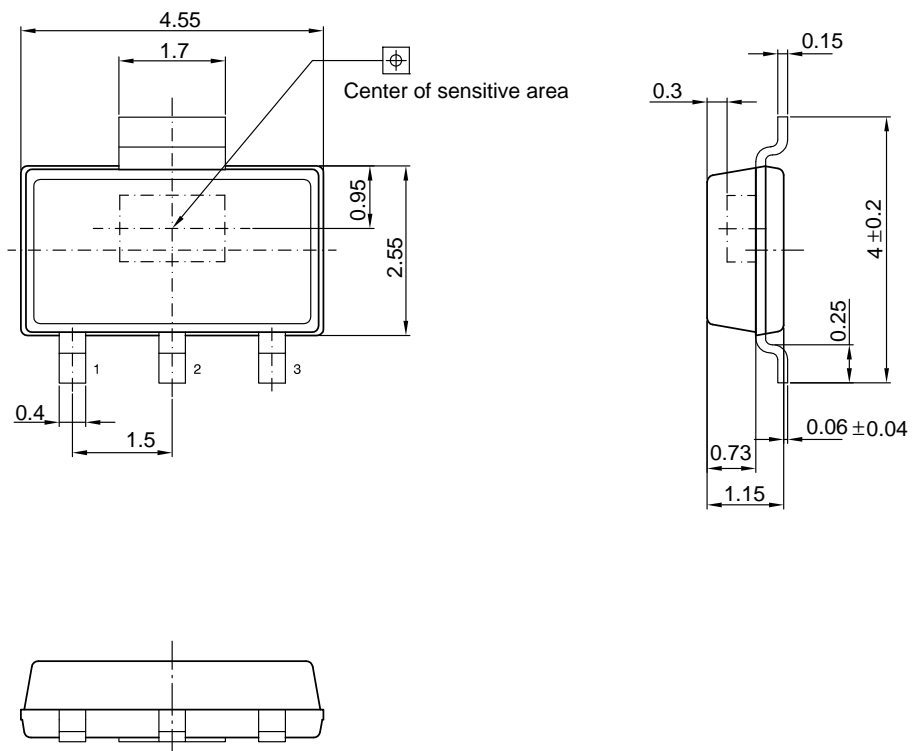

X-ON Electronics

Largest Supplier of Electrical and Electronic Components

Click to view similar products for [Board Mount Hall Effect/Magnetic Sensors](#) category:

Click to view products by [GoChip Elec Tech](#) manufacturer:

Other Similar products are found below :

[HGPRDT005A](#) [AH1894-FA-7](#) [AH277AZ4-AG1](#) [AV-10448](#) [SS41C](#) [AH1894-Z-7](#) [TLE4917](#) [TLE4946-1L](#) [TLE4976L](#) [SS85CA](#)
[BU52003GUL-E2](#) [AH277AZ4-BG1](#) [AH3376-P-B](#) [TLE4941](#) [TLE4945-2L](#) [AH3360-FT4-7](#) [TLE4941-1](#) [AH374-P-A](#) [SS41-JL](#) [AH1913-W-7](#)
[AH3373-P-B](#) [MA732GQ-Z](#) [MA330GQ-Z](#) [S-57K1NBL2A-M3T2U](#) [S-57P1NBL9S-M3T4U](#) [S-576ZNL2B-L3T2U](#) [S-576ZNL2B-A6T8U](#) [S-](#)
[57P1NBL0S-M3T4U](#) [S-57A1NSL1A-M3T2U](#) [S-57K1RBL1A-M3T2U](#) [S-57P1NBH9S-M3T4U](#) [S-57P1NBH0S-M3T4U](#) [S-57A1NSH1A-](#)
[M3T2U](#) [S-57A1NSH2A-M3T2U](#) [S-57K1NBH1A-M3T2U](#) [S-57A1NNL1A-M3T2U](#) [S-5701BC11B-L3T2U5](#) [S-57GNNL3S-A6T8U](#) [S-](#)
[57TZ1L1S-A6T8U](#) [S-57GSNL3S-A6T8U](#) [S-5716ANDH0-I4T1U](#) [S-57GSNL5S-L3T2U](#) [S-57GDNL3S-L3T2U](#) [S-57GNNL3S-L3T2U](#) [S-](#)
[57RBNL8S-L3T2U](#) [S-57RBNL9S-A6T8U](#) [S-57RB1L8S-L3T2U](#) [S-57GDNL5S-L3T2U](#) [S-57RBNL9S-L3T2U](#) [S-57TZ1L1S-L3T2U](#)