

◆ General Description

The GH266A is an integrated Hall sensor with output driver designed for electronic commutation of brush-less DC motor applications. The device includes an on-chip Hall sensor for magnetic sensing, an amplifier that amplifies the Hall voltage, a wave shaping circuit to provide switching hysteresis for noise rejection and two complementary open-drain drivers for sinking large load current. It also includes an internal voltage regulator which allows a wide operating supply voltage ranges.

Placing the device in a variable magnetic field, if the magnetic flux density is larger than threshold B_{OP} , the pin OUT1 will be turned low (on) and pin OUT2 will be turned high (off). This output state is held until the magnetic flux density reverses and falls below B_{RP} , then causes OUT1 to be turned high (off) and OUT2 turned low (on). GH266A is

rated for operation over temperature range from -40°C to $+85^{\circ}\text{C}$ and voltage range from 3.5V to 28V.

The GH266A is available in TO-94 (SIP-4L) package.

◆ Features

- On Chip Hall Effect Sensor
- 3.5~28V Power Supply Voltage
- Drivers Allow 400mA Without Overheating
- Built-in Zener Diodes Protection for Output Driver
- Embedded Over-Temperature Protection
- Precise Magnetic Switching Thresholds

◆ Applications

- Dual-coil Brushless DC Fan
- Dual-coil Brushless DC Motor

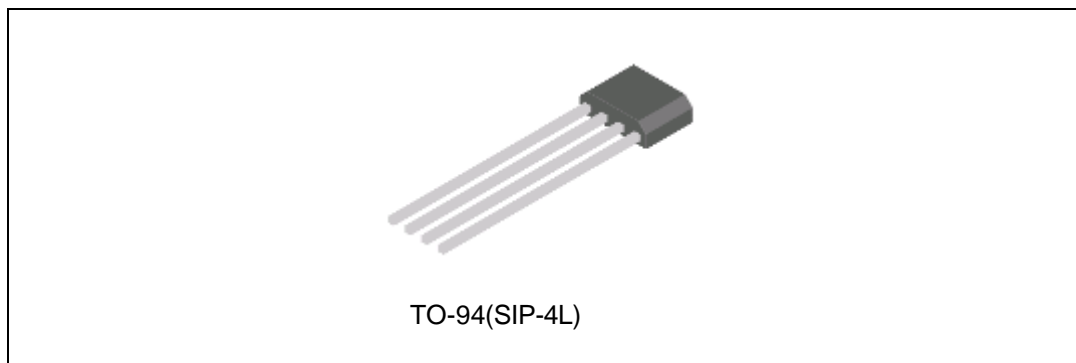

Figure 1. Package Type of GH266A

◆ Ordering Information

Package	Temperature Range	Part Number	Marking ID	Packing Type
TO-94(SIP-4L)	-40 to 85°C	GH266AEUB	GH266A	Bulk

◆ Pin Configuration

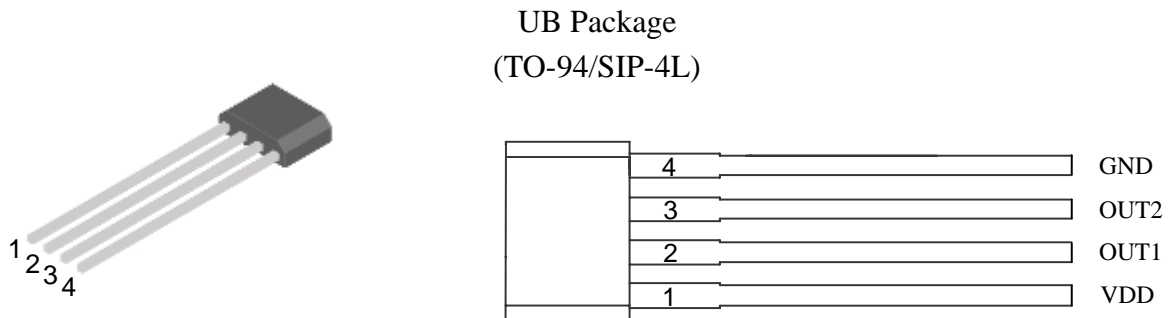

Figure 2. Pin Configuration of GH266A (Front View)

◆ Pin Description

Pin Number	Pin Name	Function
1	VDD	Power Supply Pin
2	OUT1	Open-Drain Output Pin 1
3	OUT2	Open-Drain Output Pin 2
4	GND	Ground Pin

◆ Functional Block Diagram

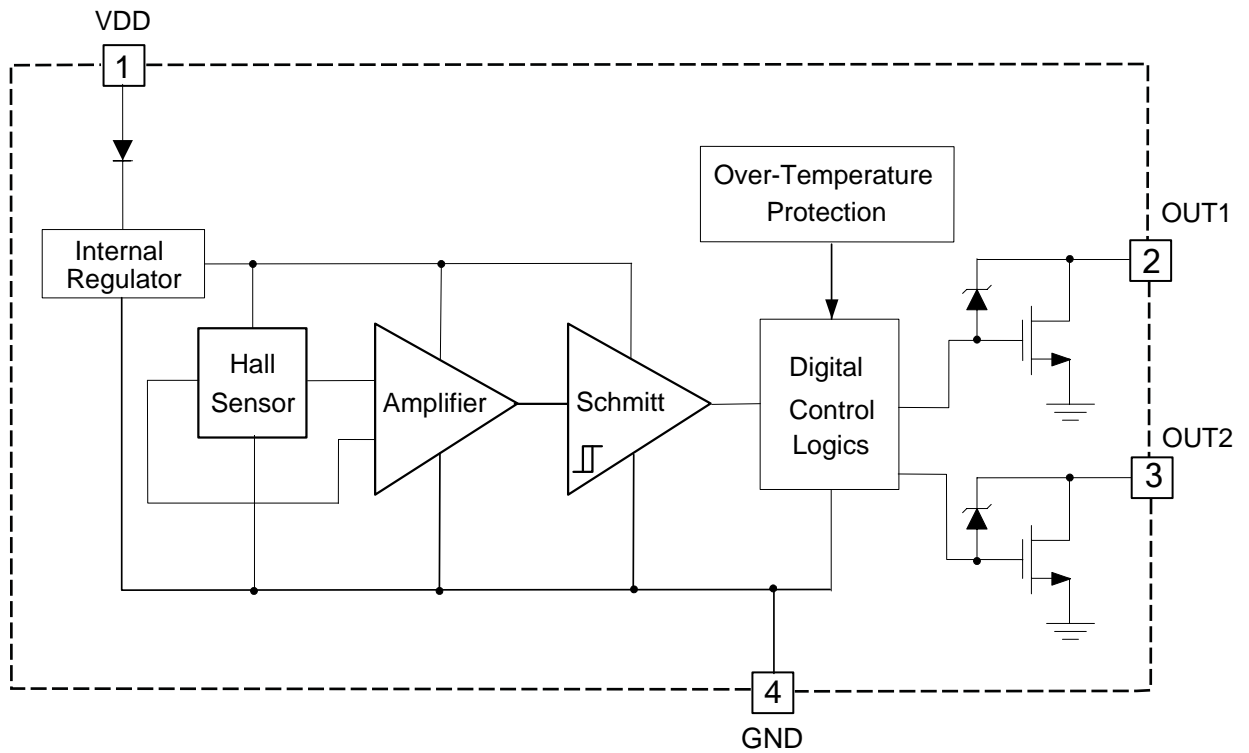

Figure 3. Functional Block Diagram of GH266A

◆ **Absolute Maximum Ratings** $T_A = 25^\circ\text{C}$ (Note 1)

Parameter	Symbol	Condition	Value	Unit
Supply Voltage (Continuous)	$V_{DD(\text{CONT})}$		30	V
Supply Voltage (Peak)	$V_{DD(\text{PEAK})}$	$\leq 100\text{s}$	40	V
Supply current (Fault)	$I_{DD(\text{FAULT})}$		3.5	mA
Continuous current	$I_{OUT(\text{CONT})}$		400	mA
Hold current	$I_{OUT(\text{HOLD})}$		600	mA
Peak current	$I_{OUT(\text{PEAK})}$	$\leq 200\mu\text{s}$	800	mA
Power dissipation	P_D	TO-94(SIP-4L)	550	mW
Thermal Resistance (Junction to Ambient)	θ_{JA}	TO-94(SIP-4L)	227	$^\circ\text{C}/\text{W}$
Thermal Resistance (Junction to Case)	θ_{JC}	TO-94(SIP-4L)	49	$^\circ\text{C}/\text{W}$
Operating Junction temperature	T_J		-40 to 150	$^\circ\text{C}$
Storage temperature	T_{STG}		-55 to 160	$^\circ\text{C}$
Output Clamp Voltage of Zener Diode	V_Z		43	V
Magnetic Flux Density	B		Unlimited	Gauss
IR-Reflow Lead Temperature	T_P	10s	260	$^\circ\text{C}$

◆ **Recommended Operating Conditions**

Parameter	Symbol	Min	Max	Unit
Power Supply Voltage	V_{DD}	3.5	28	V
Operation Temperature	T_A	-40	85	$^\circ\text{C}$

Note 1: Stresses greater than those listed under “Absolute Maximum Ratings” may cause permanent damage to the device. These are stress ratings only, and functional operation of the device at these or any other conditions beyond those indicated above “Recommended Operating Conditions” is not implied. Exposure to “Absolute Maximum Ratings” for extended periods may affect device reliability.

◆ Electrical Characteristics

$V_{DD}=24V$, $T_A=25^{\circ}C$, unless otherwise specified.

Parameter	Symbol	Conditions	Min	Typ	Max	Unit
Supply Voltage	V_{DD}	Operating	3.5	-	28	V
Supply Current	I_{DD}	Output open	-	1.3	2.5	mA
Output Current	I_{OUT}		-		400	mA
Output Leakage Current	$I_{LEAKAGE}$	$V_{OUT}=28V$	-	0.1	10	μA
Output Driver ON-Resistance	R_{DSON}	$T_A=25^{\circ}C$	-	1.0	1.4	Ohm
		$T_A=85^{\circ}C$	-	1.4	1.8	Ohm
Thermal Shutdown Threshold	T_{SD}		165	-	-	$^{\circ}C$

◆ Magnetic Characteristics

$V_{DD}=12V$, $T_A=25^{\circ}C$, unless otherwise specified.

Parameter	Symbol	Min	Typ	Max	Unit
Operating Point	B_{OP}	-	30	60	Gauss
Releasing Point	B_{RP}	-60	-30	-	Gauss
Hysteresis	B_{HYS}	-	60	-	Gauss

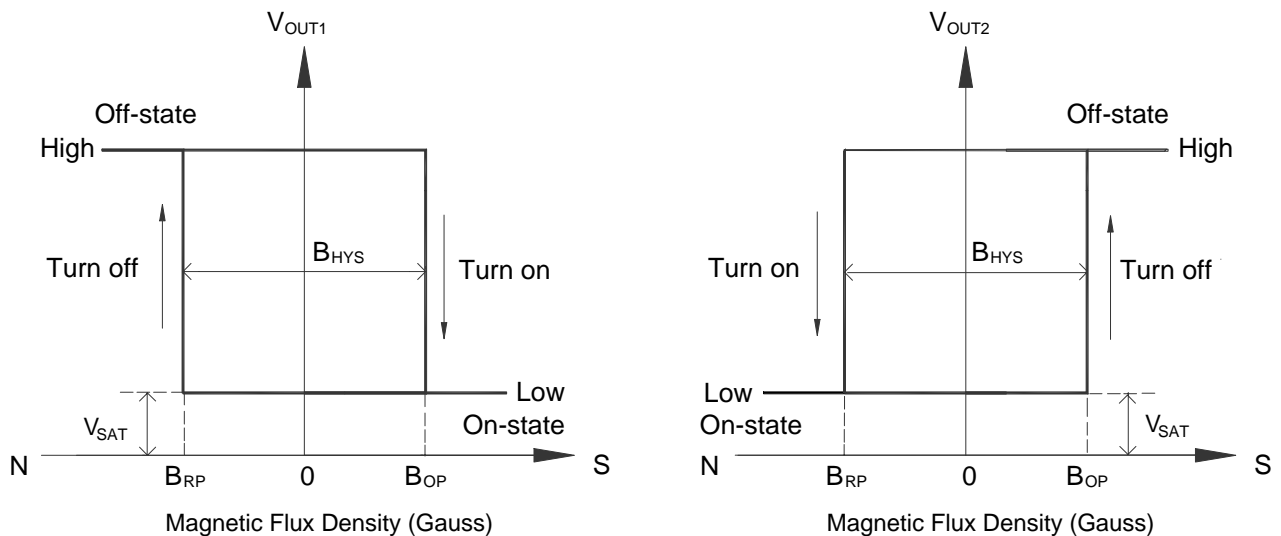

◆ Typical Application

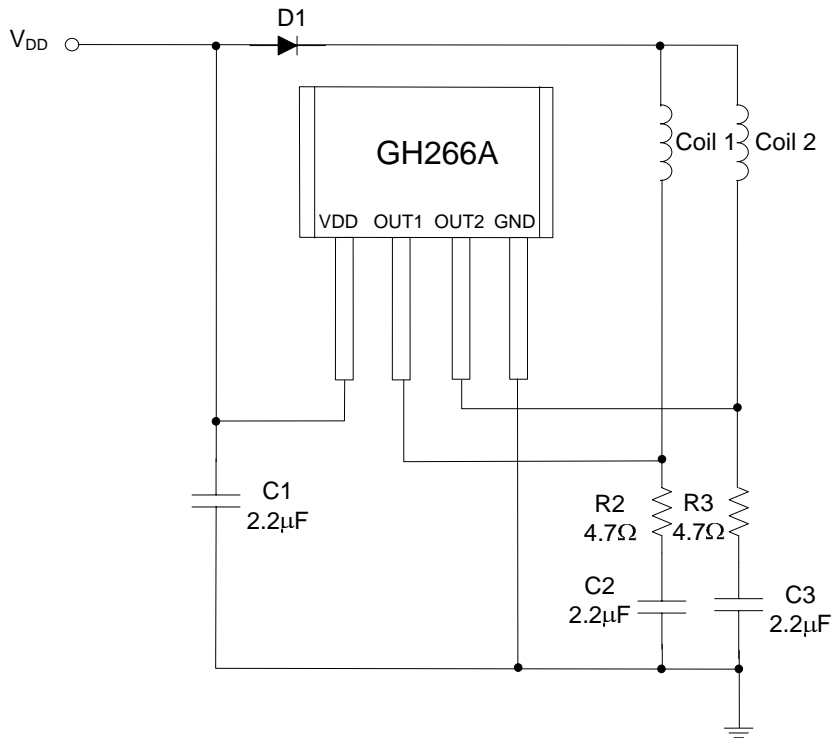

Figure6. Typical Application of GH266A

Note:

1. D1 is an ordinary diode used to filter the noise from VDD and It is optional.
2. C1=C2=C3=2.2µF typical, electrolytic capacitors are better. They should be fine tuned based on system design.
3. R2=R3=4.7Ω typical. They can be cancelled according to system requirement.

◆ Marking Information

(TO-94/SIP-4L)

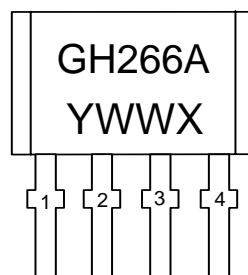

GH266A: Part No.
Y: Year, 0~9, ex: "7"=2017
WW: Nth Week, 01~52
X: Internal Code

◆ Package Information

(UB: TO-94/SIP-4L) Unit: mm

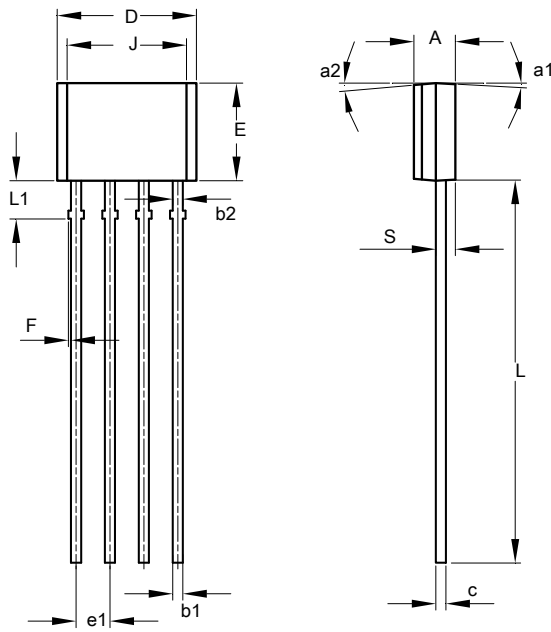
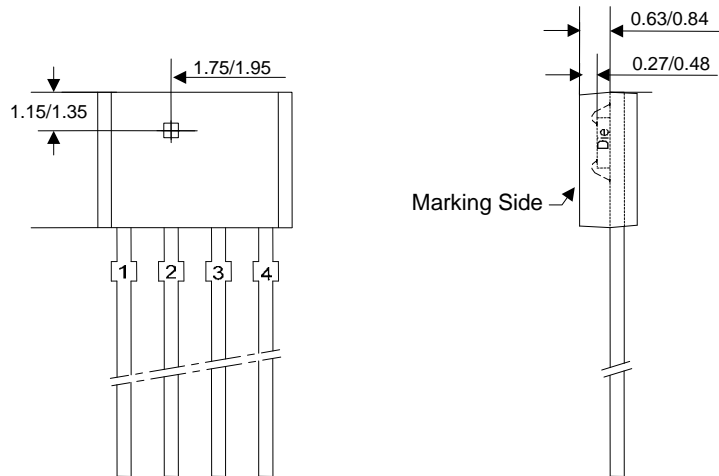

Size	MIN.	MAX.	TYP.
A	1.45	1.65	1.55
b1	0.38	0.44	0.40
b2	-	-	0.48
c	0.35	0.45	0.40
D	5.12	5.32	5.22
e1	1.24	1.30	1.27
E	3.55	3.75	3.65
F	0.00	0.20	-
J	4.10	4.30	4.20
L	14.00	14.60	14.30
L1	1.32	1.52	1.42
S	0.63	0.83	0.73
a1	-	5°	3°
a2	4°	7°	5°
a3	10°	12°	11°
a4	5°	7°	6°

Unit: mm

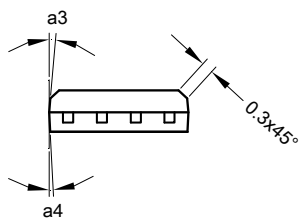

X-ON Electronics

Largest Supplier of Electrical and Electronic Components

Click to view similar products for [Display Drivers & Controllers](#) category:

Click to view products by [GoChip Elec Tech](#) manufacturer:

Other Similar products are found below :

[ICB2FL01G](#) [LC74761M-9006-E](#) [HV5812PJ-G-M904](#) [TW8813-LB2-GR](#) [TW8819AT-NA2-GR](#) [TW8825-LA1-CR](#) [TW8811-PC2-GR](#)
[LX27901IDW](#) [BD8153EFV-E2](#) [LX1688IPW](#) [BD83854MUV-E2](#) [S1D13742F01A200](#) [LX1688CPW](#) [HV857LK7-G](#) [DLPA1000YFFT](#)
[ICB2FL01GXUMA2](#) [DLPC3435CZEZ](#) [DLP2000FQC](#) [SC401U](#) [PAD1000YFFR](#) [S1D13746F01A600](#) [FIN324CMLX](#) [BL8023C](#)
[DLPC6421ZPC](#) [HV852K7-G](#) [HV859K7-G](#) [HV857K7-G](#) [DIO2133CT14](#) [DLP4500NIRAFQD](#) [DLP9500BFLN](#) [S1D13515F00A100](#)
[S1D13517F00A100](#) [S1D13743F00A200](#) [S1D13748F00A100](#) [S1D13A04F00A100](#) [S1D13L01F00A100](#) [S1D13L03F00A100-40](#) [TW8816-](#)
[LA3-GRS](#) [TW8816-LB3-CR](#) [TW8816-LB3-GRS](#) [TW8820-LA1-CR](#) [TW8823-LC2-CE](#) [S1D13513B01B100](#) [TW2836-BA1-GR](#) [MP1015EM-](#)
[LF-Z](#) [MAX749CSA+T](#) [MAX4820EUP+T](#) [S1D13700F02A100](#) [S1D13748B00B100](#) [MAX749CPA+](#)