

## ◆ General Description

The GH9280 is a one-chip IC solution for driving two-coil brushless DC cooling fans. This IC consists of voltage reference, Hall sensor, signal amplifier, wave shaping circuit, locked rotor detector, locked rotor protection and restart circuit, output drive circuit, etc.. To allow survival in a harsh environment and in consideration of low cost, the GH9280 has been designed with many functions internally, and requires less external components.

When there is no motion for 0.5 second, the IC will detect locked rotor conditions, enter protection mode automatically and disable two outputs for 4 seconds. Then, it will turn on driver current from one channel for 0.5 second. If it still fails to detect fan rotation, the GH9280 will shut off the outputs for 4 seconds again. This sequence will be repeated until rotation condition is detected and the IC enters normal operation mode. This on/off cycling reduces the

average current about 80%. This function prevents the chip and the fan from overheating and damage due to long time locked rotor.

The GH9280 is available in TO-94 (SIP-4L) package.

## ◆ Features

- On Chip Hall Effect Sensor
- 3.5~18V Power Supply Voltage
- Drivers Allow 500mA Without Overheating
- Locked Rotor Shutdown and Auto Restart
- Built-in Zener Diodes Protection for Output Driver
- Embedded Over-Temperature Protection
- Precise Magnetic Switching Thresholds

## ◆ Applications

- Dual-coil Brushless DC Fan
- Dual-coil Brushless DC Motor

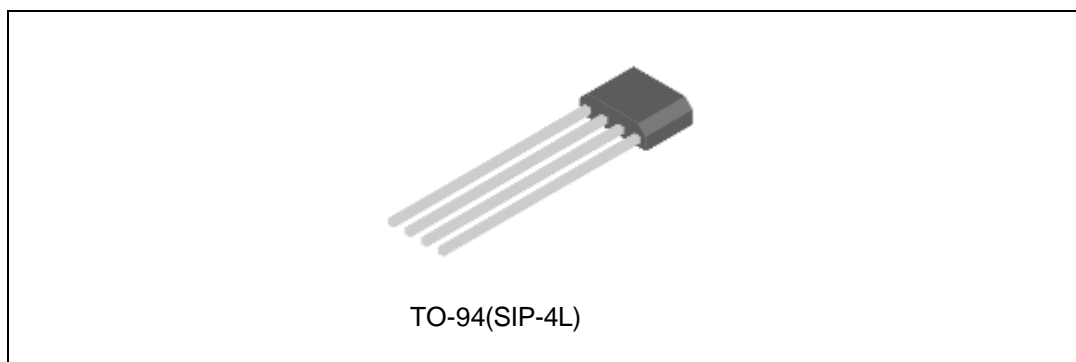

Figure 1. Package Type of GH9280

## ◆ Ordering Information

Package	Temperature Range	Part Number	Marking ID	Packing Type
TO-94(SIP-4L)	-40 to 105 °C	GH9280HUB	GH9280	Bulk

### ◆ Pin Configuration

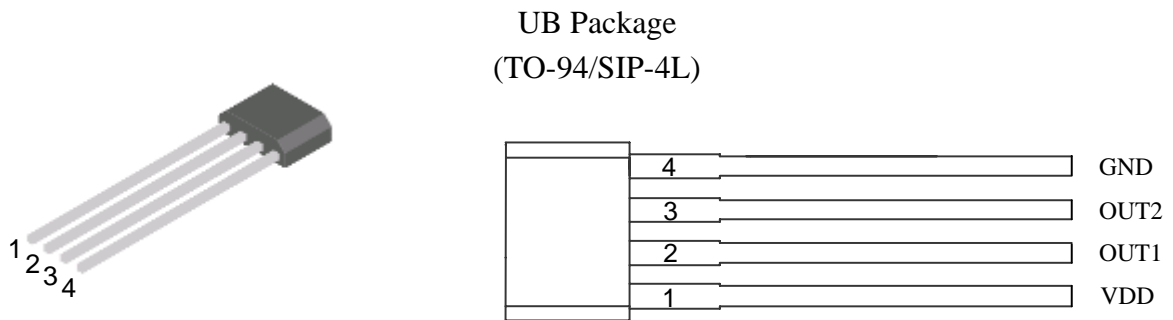

Figure 2. Pin Configuration of GH9280 (Front View)

### ◆ Pin Description

Pin Number	Pin Name	Function
1	VDD	Power Supply Pin
2	OUT1	Open-Drain Output Pin 1
3	OUT2	Open-Drain Output Pin 2
4	GND	Ground Pin

◆ Functional Block Diagram

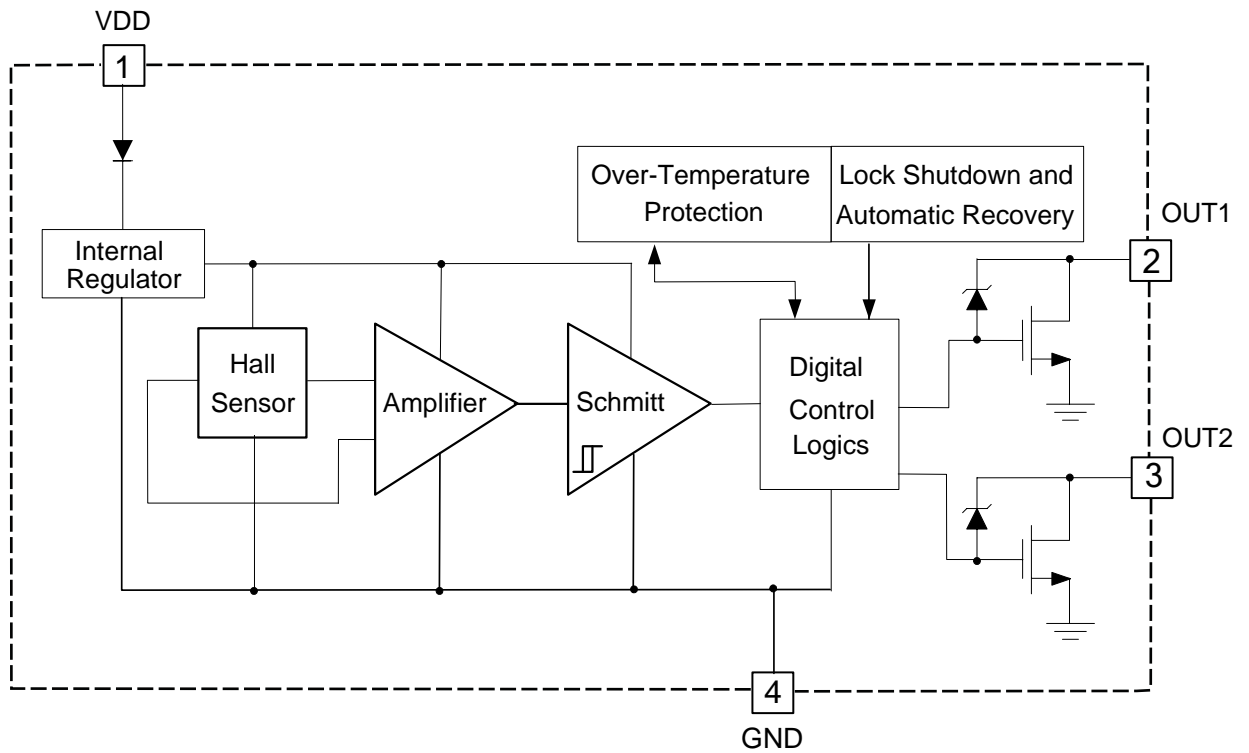

Figure 3. Functional Block Diagram of GH9280

◆ **Absolute Maximum Ratings**  $T_A = 25^\circ\text{C}$  (Note 1)

Parameter	Symbol	Condition	Value	Unit
Supply Voltage (Continuous)	$V_{DD(\text{CONT})}$		22	V
Supply Voltage (Peak)	$V_{DD(\text{PEAK})}$	$\leq 100\text{s}$	33	V
Supply current (Fault)	$I_{DD(\text{FAULT})}$		3.5	mA
Continuous current	$I_{OUT(\text{CONT})}$		500	mA
Hold current	$I_{OUT(\text{HOLD})}$		700	mA
Peak current	$I_{OUT(\text{PEAK})}$	$\leq 200\mu\text{s}$	1200	mA
Power dissipation	$P_D$	TO-94(SIP-4L)	550	mW
Thermal Resistance (Junction to Ambient)	$\theta_{JA}$	TO-94(SIP-4L)	227	$^\circ\text{C}/\text{W}$
Thermal Resistance (Junction to Case)	$\theta_{JC}$	TO-94(SIP-4L)	49	$^\circ\text{C}/\text{W}$
Operating Junction temperature	$T_J$		-40 to 150	$^\circ\text{C}$
Storage temperature	$T_{STG}$		-55 to 160	$^\circ\text{C}$
Output Clamp Voltage of Zener Diode	$V_Z$		33	V
Magnetic Flux Density	B		Unlimited	Gauss
IR-Reflow Lead Temperature	$T_P$	10s	260	$^\circ\text{C}$

◆ **Recommended Operating Conditions**

Parameter	Symbol	Min	Max	Unit
Power Supply Voltage	$V_{DD}$	3.5	18	V
Operation Temperature	$T_A$	-40	105	$^\circ\text{C}$

Note 1: Stresses greater than those listed under “Absolute Maximum Ratings” may cause permanent damage to the device. These are stress ratings only, and functional operation of the device at these or any other conditions beyond those indicated above “Recommended Operating Conditions” is not implied. Exposure to “Absolute Maximum Ratings” for extended periods may affect device reliability.

## ◆ Electrical Characteristics

$V_{DD}=12V$ ,  $T_A=25^{\circ}C$ , unless otherwise specified.

Parameter	Symbol	Conditions	Min	Typ	Max	Unit
Supply Voltage	$V_{DD}$	Operating	3.5		18	V
Supply Current	$I_{DD}$	Output open		1.3	2.5	mA
Output Current	$I_{OUT}$				500	mA
Output Leakage Current	$I_{LEAKAGE}$	$V_{OUT}=18V$		0.1	10	$\mu A$
Output Driver ON-Resistance	$R_{DS(ON)}$	$T_A=25^{\circ}C$		1.1	1.5	Ohm
		$T_A=85^{\circ}C$		1.6	2.1	Ohm
Output ON Time (Restart)	$t_{ON}$	Locked Rotor		0.5		s
Output OFF Time	$t_{OFF}$	Locked Rotor		4.0		s
Thermal Shutdown Threshold	$T_{SD}$		160			$^{\circ}C$

## ◆ Magnetic Characteristics

$V_{DD}=12V$ ,  $T_A=25^{\circ}C$ , unless otherwise specified.

Parameter	Symbol	Min	Typ	Max	Unit
Operating Point	$B_{OP}$		25	50	Gauss
Releasing Point	$B_{RP}$	-50	-25		Gauss
Hysteresis	$B_{HYS}$		50		Gauss

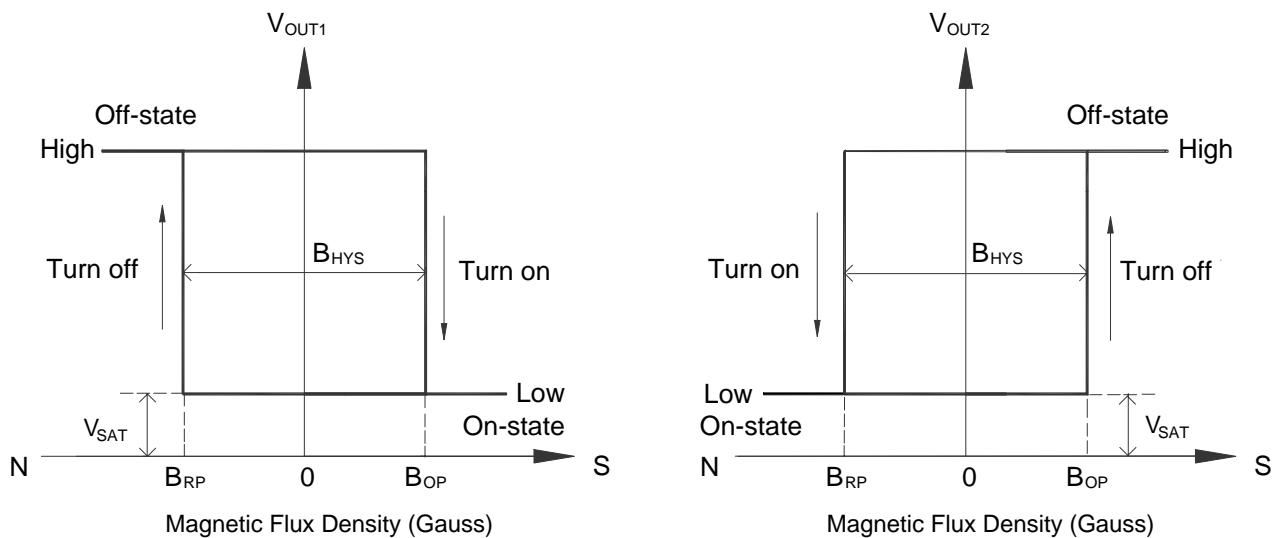

### ◆ Typical Application

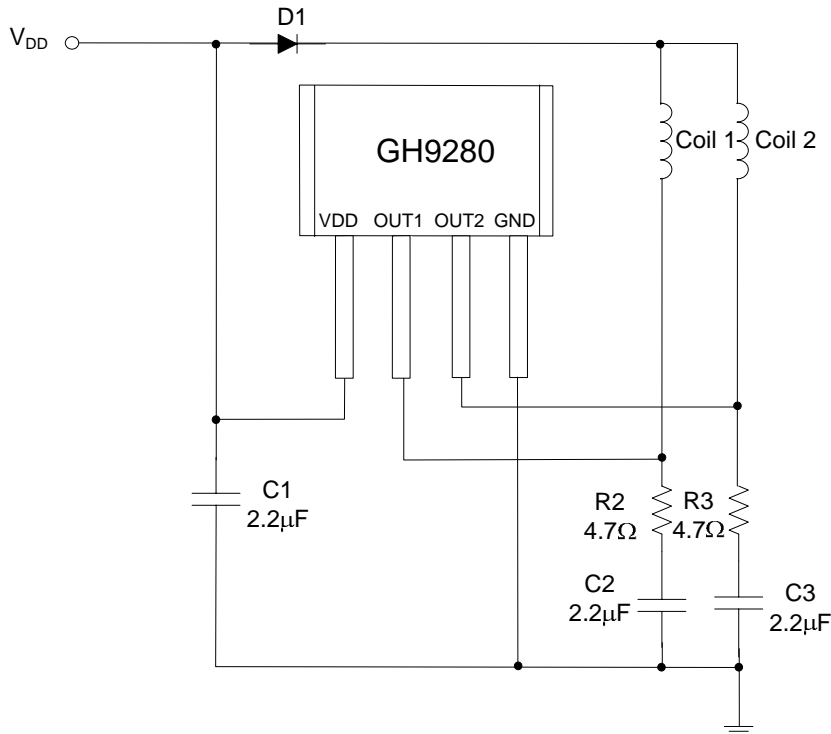

Figure6. Typical Application of GH9280

Note:

1. D1 is an ordinary diode used to filter the noise from VDD and It is optional.
2. C1=C2=C3=2.2µF typical, electrolytic capacitors are better. They should be fine tuned based on system design.
3. R2=R3=4.7Ω typical. They can be cancelled according to system requirement.

### ◆ Marking Information

(TO-94/SIP-4L)

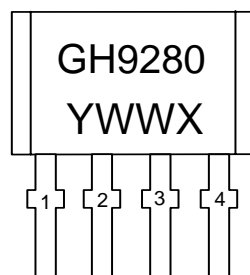

GH9280: Part No.  
Y: Year, 0~9, ex: "7"=2017  
WW: Nth Week, 01~52  
X: Internal Code

◆ Package Information

(UB: TO-94/SIP-4L) Unit: mm

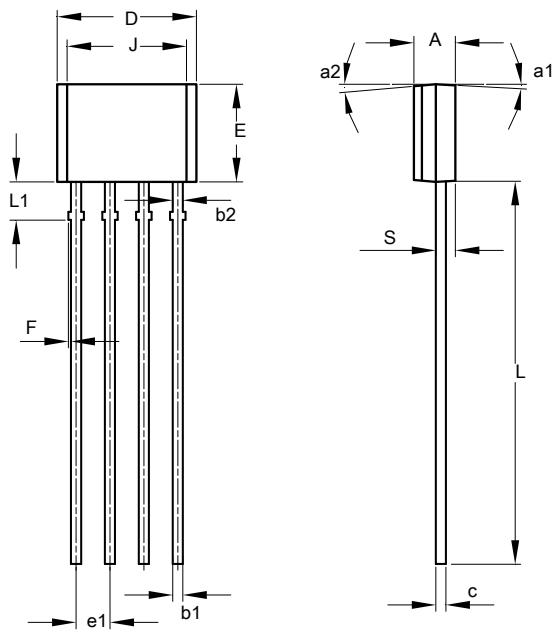
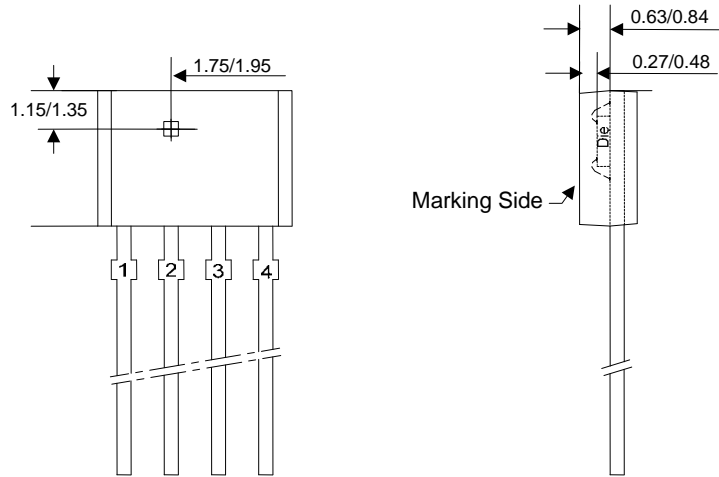

Size	MIN.	MAX.	TYP.
A	1.45	1.65	1.55
b1	0.38	0.44	0.40
b2	-	-	0.48
c	0.35	0.45	0.40
D	5.12	5.32	5.22
e1	1.24	1.30	1.27
E	3.55	3.75	3.65
F	0.00	0.20	-
J	4.10	4.30	4.20
L	14.00	14.60	14.30
L1	1.32	1.52	1.42
S	0.63	0.83	0.73
a1	-	5°	3°
a2	4°	7°	5°
a3	10°	12°	11°
a4	5°	7°	6°

Unit: mm

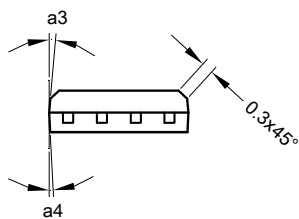

## X-ON Electronics

Largest Supplier of Electrical and Electronic Components

*Click to view similar products for [Motor/Motion/Ignition Controllers & Drivers](#) category:*

*Click to view products by [GoChip Elec Tech](#) manufacturer:*

Other Similar products are found below :

[LV8774Q-AH](#) [MC33931EKR2](#) [FSB50250UTD](#) [FSB50550TB2](#) [FSBF15CH60BTH](#) [MSVCPM2-63-12](#) [MSVGW45-14-2](#) [MSVGW54-14-3](#)  
[NTE7043](#) [LA6565VR-TLM-E](#) [LB11650-E](#) [LB1837M-TLM-E](#) [LB1845DAZ-XE](#) [LC898300XA-MH](#) [SS30-TE-L-E](#) [AMIS30621AUA](#)  
[LV8281VR-TLM-H](#) [BA5839FP-E2](#) [IRAM236-1067A](#) [LA6584JA-AH](#) [LB11847L-E](#) [NCV70501DW002R2G](#) [AH293-PL-B](#) [TND315S-TL-2H](#)  
[FNA23060](#) [FSB50250AB](#) [FNA41060](#) [MSVBTC50E](#) [MSVCPM3-54-12](#) [MSVCPM3-63-12](#) [MSVCPM4-63-12](#) [FSB50550AB](#)  
[NCV70501DW002G](#) [LC898301XA-MH](#) [LV8413GP-TE-L-E](#) [MSVGW45-14-3](#) [MSVGW45-14-4](#) [MSVGW54-14-4](#) [TB6552FNG,C,8,EL](#)  
[STK984-091A-E](#) [LB11651-E](#) [IRSM515-025DA4](#) [LV8127T-TLM-H](#) [MC33812EKR2](#) [IKCM10H60GA](#) [LA6588MC-AH](#) [MC33PT2000AF](#)  
[TDA21801](#) [LB11851FA-BH](#) [LA6586FA-BH](#)