

Specification of MEMS Microphone (RoHS Compliance & Halogen Free)

Customer Name :

Customer Model :

GoerTek Model : S18OB381-032

GoerTek		CUSTOMER APPROVAL
<u>DESIGN</u>	<u>Jasen</u> 2018.07.27	
<u>CHKD</u>	<u>Samual</u> 2018.07.27	
<u>STANDARD</u>	<u>Sweety</u> 2018.07.27	
<u>APVD</u>	<u>Daniel</u> 2018.07.27	

Tel : + 86 536 3051234

E- Mail : goertek@goertek.com

Website: <http://www.goertek.com>

Address: No.268 Dongfang Road, High-Tech Industry
Development District, Weifang, Shandong, P.R.C.

Restricted

1 Security Warning

The information contained in this document is the exclusive property of GoerTek Inc. and should not be disclosed to any third party without the written consent of GoerTek Inc..

2 Publication History

Version	Description	Date	Author	Approved
1.0	New Design	2018.07.27	Jasen	Daniel

Contents

1	Introduction	4
2	Test Condition	4
3	Electrical Characteristics	4
4	Frequency Response Curve	5
5	Measurement Circuit	5
6	Test Setup Drawing	5
7	Mechanical Characteristics	6
7.1	Appearance Drawing	6
7.2	Weight	6
8	Reliability Test	7
8.1	Vibration Test	7
8.2	Drop Test	7
8.3	Temperature Test	7
8.4	Humidity Test	7
8.5	Mechanical Shock Test	7
8.6	Thermal Shock Test	7
8.7	Reflow Test	7
8.8	Electrostatic Discharge Test	7
9	Package	8
9.1	Tape Specification	8
9.2	Reel Dimension	9
9.3	The Content of Box	9
9.4	Packing Explain	10
10	Storage and Transportation	10
11	Land Pattern Recommendation	11
11.1	The Pattern of MIC Pad	11
11.2	Recommended Soldering Surface Land Pattern	11
12	Soldering Recommendation	12
12.1	Soldering Machine Condition	12
12.2	The Drawing and Dimension of Nozzle	12
12.3	Reflow Profile	13
12.4	Rework	14
13	Cautions	14
13.1	Board Wash Restrictions	14
13.2	Nozzle Restrictions	14
13.3	Blowing Restrictions	14
13.4	Ultrasonic Restrictions	14
13.5	Case Adaption to Pressure Restrictions	14
14	Output Inspection Standard	14

1 Introduction:

MEMS MIC which is able to endure reflow temperature up to 260 °C for 50 seconds can be used in SMT process. It is widely used in telecommunication and electronics device such as mobile phone, MP3, PDAs etc.

2 Test Condition (Vs=2.0V, L=50cm)

Standard Conditions (As IEC 60268-4)	Temperature	Humidity	Air pressure
Environment Conditions	+15°C ~ +35°C	25% R.H. ~ 75% R.H.	86kPa ~ 106kPa
Basic Test Conditions	+20°C ± 2°C	60% R.H. ~ 70% R.H.	86kPa ~ 106kPa

3 Acoustic and Electrical Characteristics

Item	Symbol	Test Conditions	Min	Typ	Max	Unit
Operating Voltage Range	V _s		1.5		3.6	V
Current Consumption	I	V _s =2.0V	50		150	μA
Sensitivity	S	f=1kHz, Pin=1Pa	-39	-38	-37	dBV
S/N Ratio	SNR	f=1kHz, Pin=1Pa A-Weighted	60	65		dB
Total Harmonic Distortion	THD	94dB SPL@1kHz		0.2	0.5	%
		110dB SPL@1kHz		0.7	1.5	%
Acoustic Overload Point	AOP	10%THD@1kHz		128		dB SPL
Power Supply Rejection	PSR	100mVpp square wave@217Hz, V _s =2.0V, A-Weighted		-93		dBV
Output Impedance	Z _{out}	f=1kHz, Pin=1Pa			400	Ω
Decreasing Voltage Characteristic	ΔS	f=1kHz, Pin=1Pa V _s =3.6 --1.5V	No Change			
Directivity	D(θ)		Omnidirectional			
Load Resistor	R _L		10		100	kΩ
Load Capacitance	C _L				150	pF
V _{DD} ramp up time	t _{VDDup}	V _{DD} reaches its final value within +/-10% tolerance	0.1		2	ms

4 Frequency Response Curve and Limits

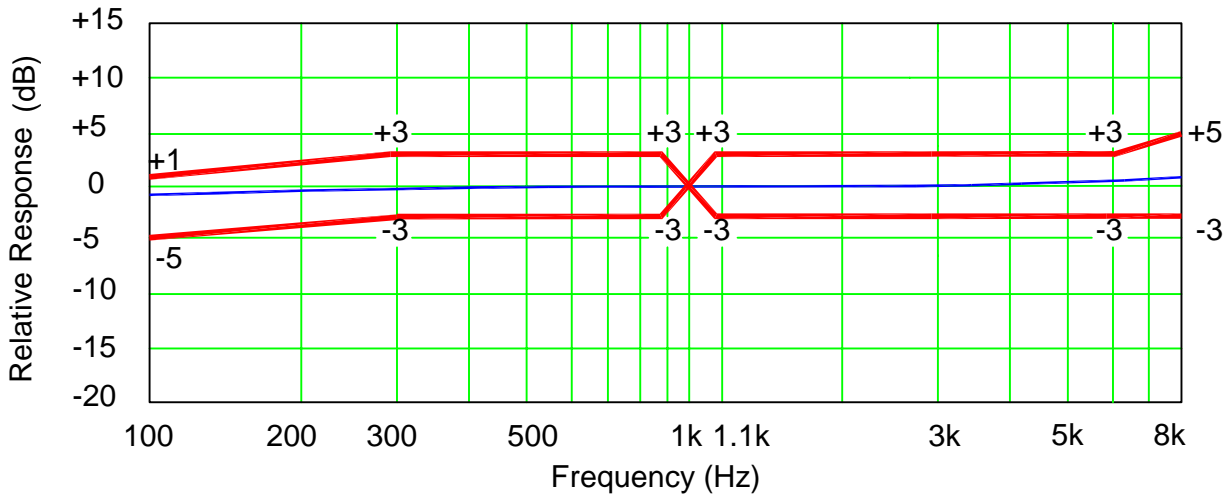

5 Measurement Circuit

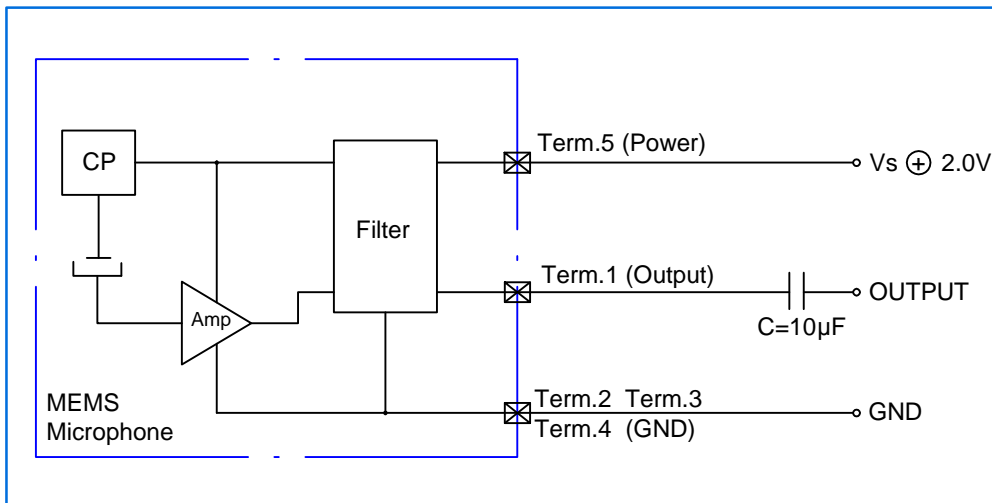

6 Test Setup Drawing

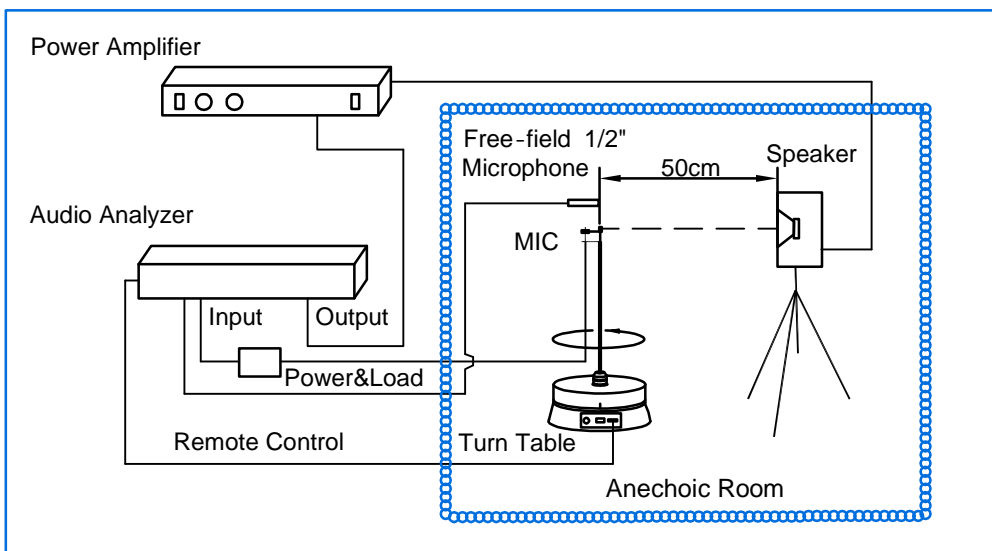

7 Mechanical Characteristics

7.1 Appearance Drawing (Unit: mm)

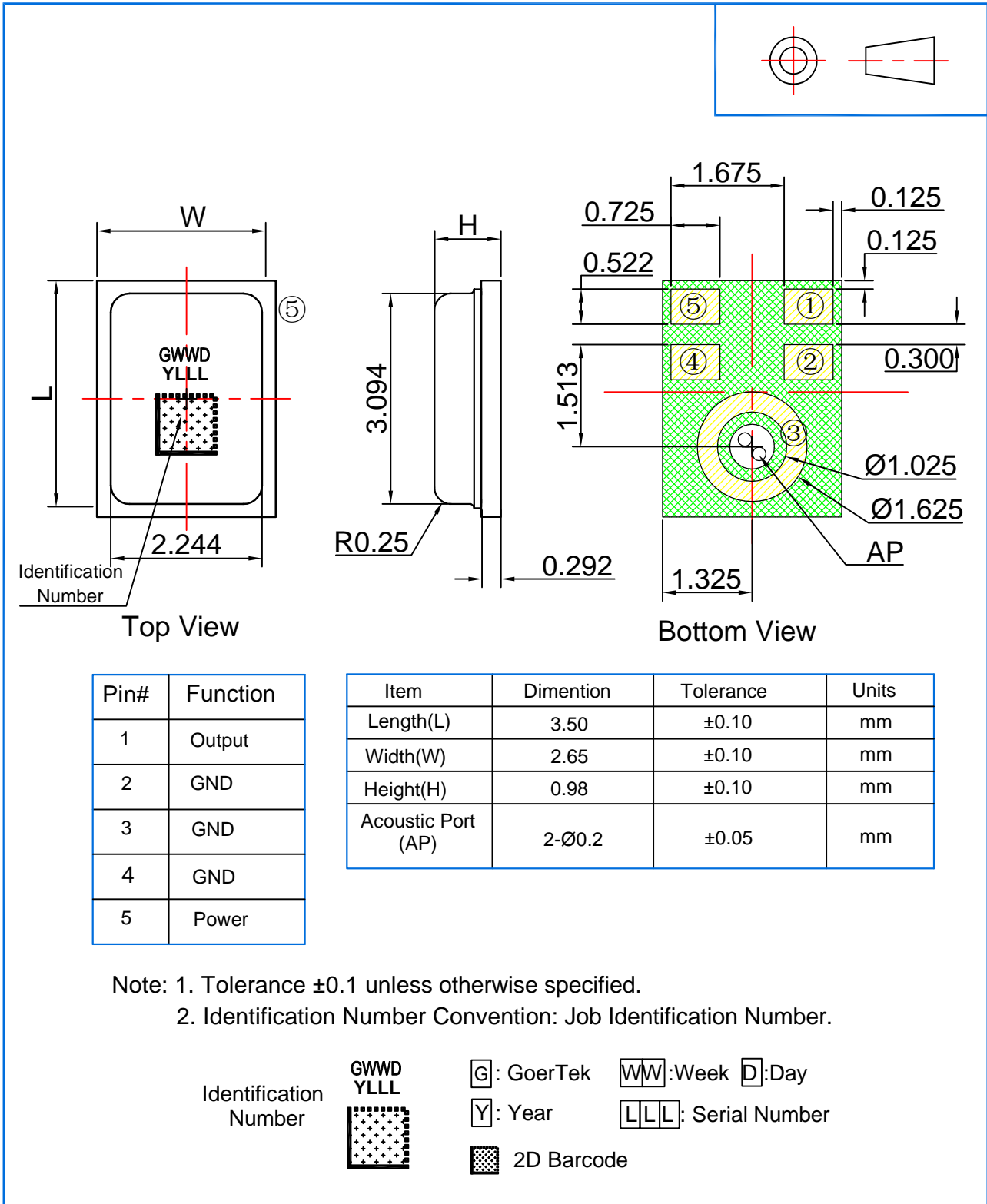

7.2 Weight

The weight of the MIC is Less than 0.04g.

8 Reliability Test

<p>8.1 Vibration Test</p>	<p>To be no interference in operation after vibrations, 4 cycles, from 20 to 2,000Hz in each direction(X,Y,Z), 48 minutes, using peak acceleration of 20g, sensitivity should vary within $\pm 3\text{dB}$ from initial sensitivity. (The measurement to be done after 2 hours of condition at 15 °C-35 °C, R.H. 25%~75%)</p>
<p>8.2 Drop Test</p>	<p>To be no interference in operation after dropped to 1.0cm steel plate 12 times from 1.5 meter height in state of JIG,JIG weight of 100g, sensitivity should vary within $\pm 3\text{dB}$ from initial sensitivity. (The measurement to be done after 2 hours of condition at 15 °C-35 °C, R.H. 25%~75%)</p>
<p>8.3 Temperature Test</p>	<p>a) After exposure at +125 °C for 200 hours, sensitivity should vary within $\pm 3\text{dB}$ from initial sensitivity. (The measurement to be done after 2 hours of condition at 15 °C-35 °C, R.H. 25%~75%) b) After exposure at -40 °C for 200 hours, sensitivity should vary within $\pm 3\text{dB}$ from initial sensitivity. (The measurement to be done after 2 hours of condition at 15 °C-35 °C, R.H. 25%~75%)</p>
<p>8.4 Humidity Test</p>	<p>After exposure at +85 °C and 85% relative humidity for 200 hours, sensitivity should vary within $\pm 3\text{dB}$ from initial sensitivity. (The measurement to be done after 2 hours of condition at 15 °C-35 °C, R.H. 25%~75%)</p>
<p>8.5 Mechanical Shock Test</p>	<p>Then subject samples to three one-half sine shock pulses (3000 g for 0.3 milliseconds) in each direction (for six axes in total) along each of the three mutually perpendicular axes for a total of 18 shocks, sensitivity should vary within $\pm 3\text{dB}$ from initial sensitivity. (The measurement to be done after 2 hours of condition at 15 °C-35 °C, R.H. 25%~75%)</p>
<p>8.6 Thermal Shock Test</p>	<p>After exposure at -40 °C for 30 minutes, at +125 °C for 30 minutes (change time 20 seconds) 32 cycles, sensitivity should vary within $\pm 3\text{dB}$ from initial sensitivity. (The measurement to be done after 2 hours of condition at 15 °C-35 °C, R.H. 25%~75%)</p>
<p>8.7 Reflow Test</p>	<p>Adopt the reflow curve of item 12.3, after three reflows, sensitivity should vary within $\pm 2\text{dB}$ from initial sensitivity. (The measurement to be done after 2 hours of condition at 15 °C-35 °C, R.H. 25%~75%)</p>
<p>8.8 Electrostatic Discharge Test</p>	<p>Under C=150pF, R=330ohm. Tested to $\pm 8\text{KV}$ contact to the case and tested to $\pm 2\text{KV}$ contact to I/O terminals.10 times. Grounding.Sensitivity should vary within $\pm 3\text{dB}$ from initial sensitivity.</p>

9 Package

9.1 Tape Specification

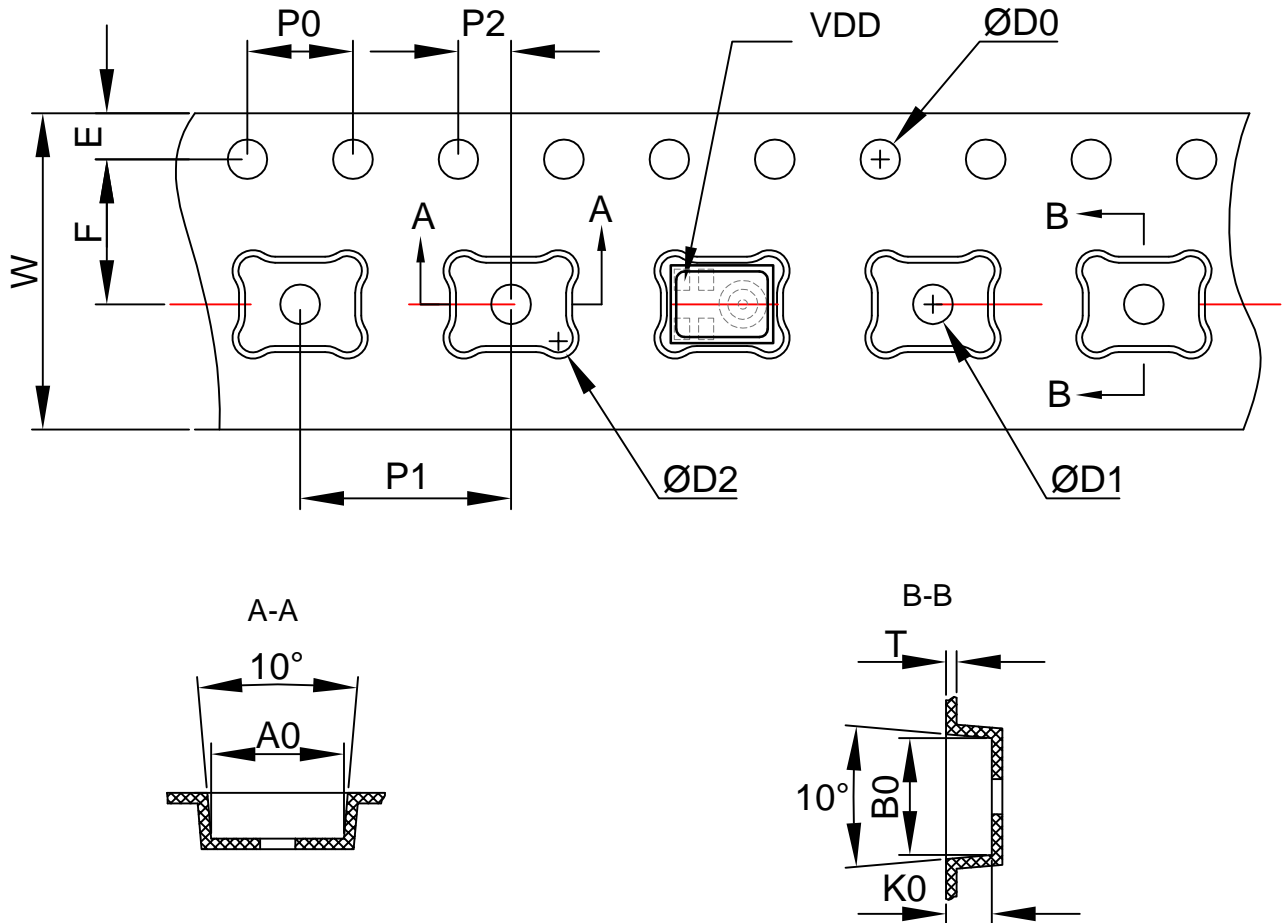

The Dimensions as Follows:

ITEM	W	E	F	ØD0	ØD1
DIM(mm)	12.0±0.30	1.75±0.10	5.5±0.05	1.50 ^{+0.10} ₀	1.00 ^{+0.10} ₀
ITEM	P0	10P0	P1	A0	B0
DIM(mm)	4.00±0.10	40.00±0.20	8.00±0.10	3.75±0.05	2.95±0.05
ITEM	K0	P2	T	ØD2	
DIM(mm)	1.30±0.10	2.00±0.05	0.30±0.05	0.50±0.10	

9.2 Reel Dimension

7" reel for sample stage

13" reel will be provided for the mass production stage

The following is 13" reel dimensions (unit:mm)

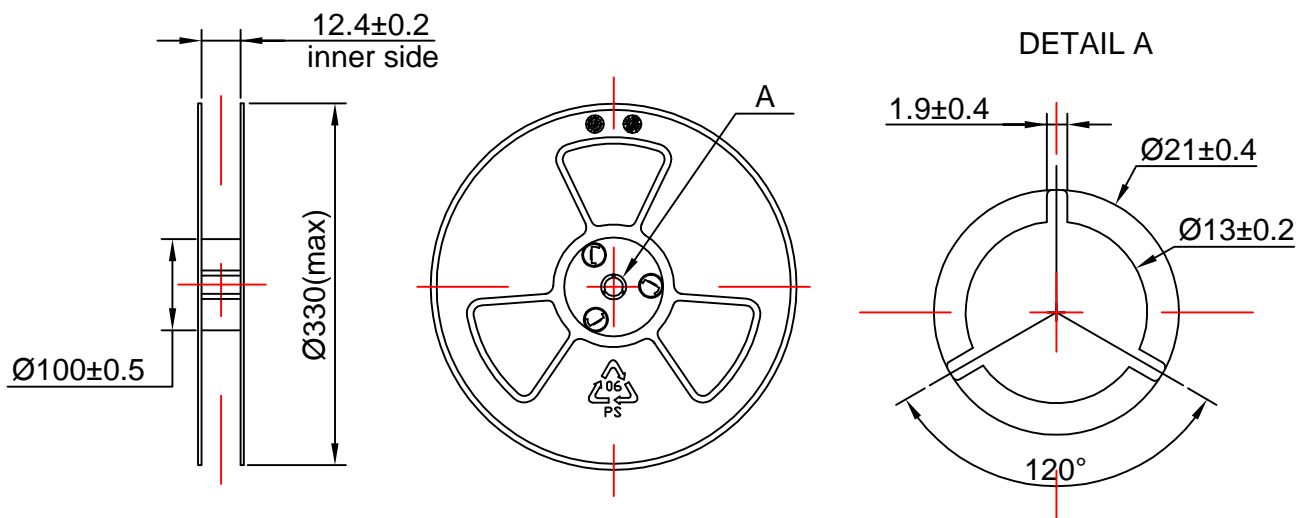

9.3 The Content of Box(13" reel)

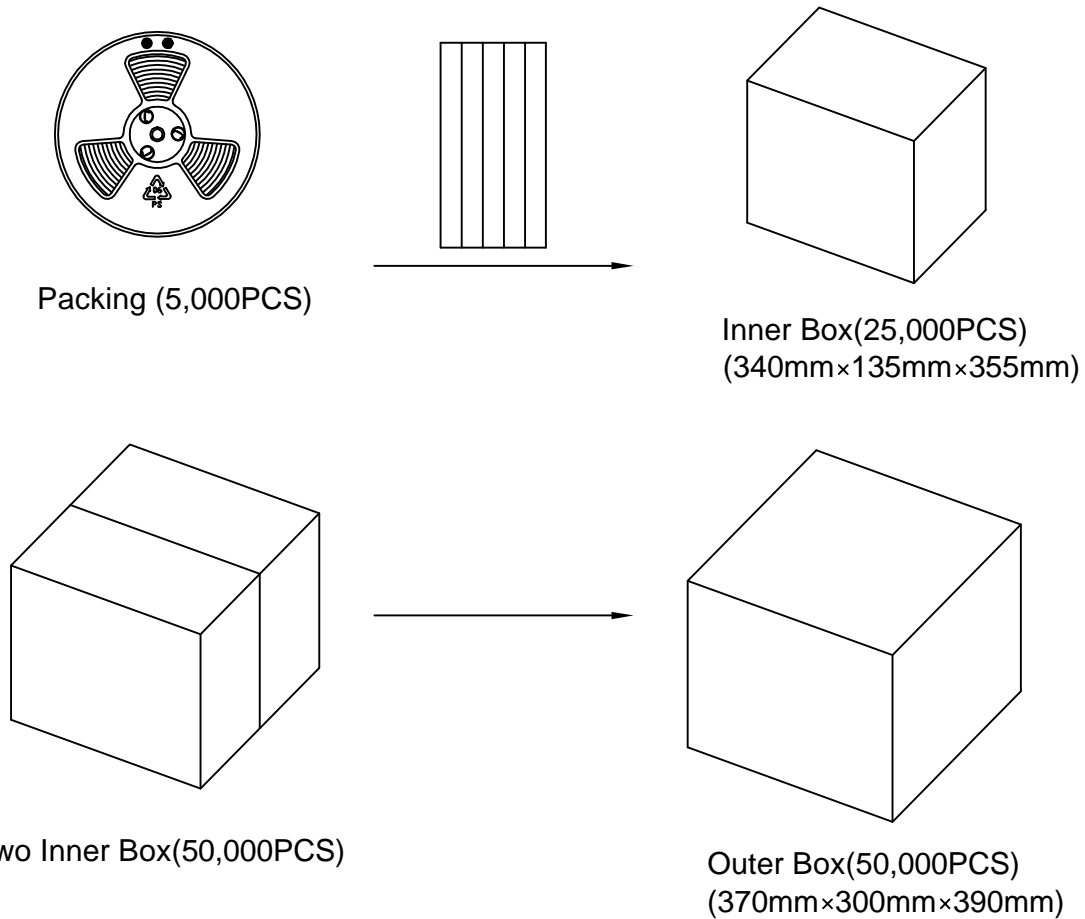

9.4 Packing Explain

9.4.1 The Label Content of the Reel

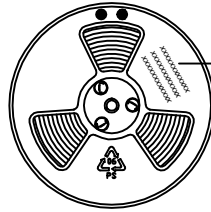

The Content Includes:
Product type, Lot, Customer P/N;
and other essential information such as
Quantity, Date etc.

9.4.2 The RoHS Label

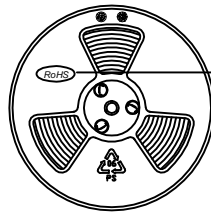

RoHS HF
Compliance Mark

10 Storage and Transportation

10.1 Keep MEMS MIC in warehouse with less than 75% humidity and without sudden temperature change, acid air, any other harmful air or strong magnetic field. Recommend storage period no more than 1 year and floor life(out of bag) at factory no more than 4 weeks.

10.2 The MEMS MIC with normal pack can be transported by ordinary conveyances. Please protect products against moist, shock, sunburn and pressure during transportation.

10.3 Storage Temperature Range : $-40^{\circ}\text{C} \sim +70^{\circ}\text{C}$

10.4 Operating Temperature Range : $-40^{\circ}\text{C} \sim +100^{\circ}\text{C}$

11 Land Pattern Recommendation

11.1 The Pattern of MIC Pad(Unit:mm)

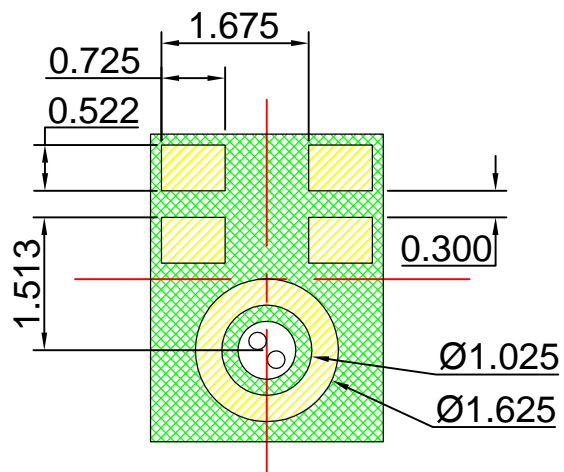

11.2 Recommended Soldering Surface Land Pattern

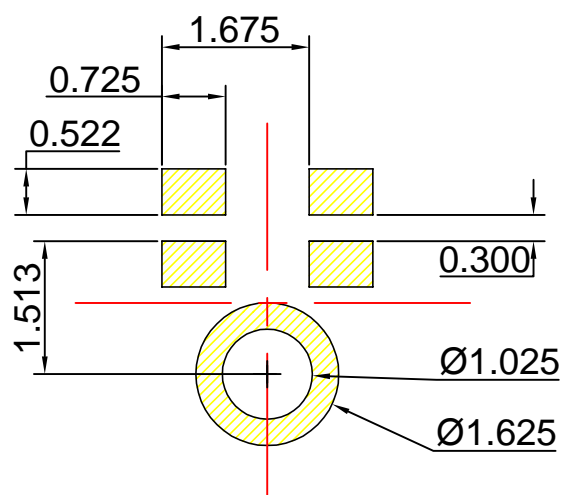

12 Soldering Recommendation

12.1 Soldering Machine Condition

Temperature Control	8 zones
Heater Type	Hot Air
Solder Type	Lead-free

12.2 The Drawing and Dimension of Nozzle

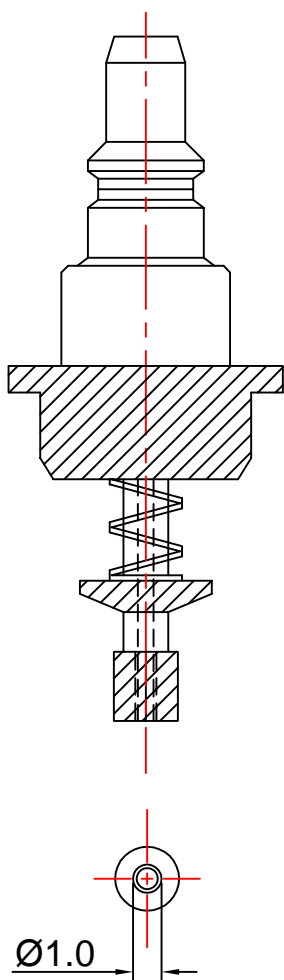

Nozzle Diameter: Ø1.0mm;
Please don't blow the acoustic port directly.

12.3 Reflow Profile

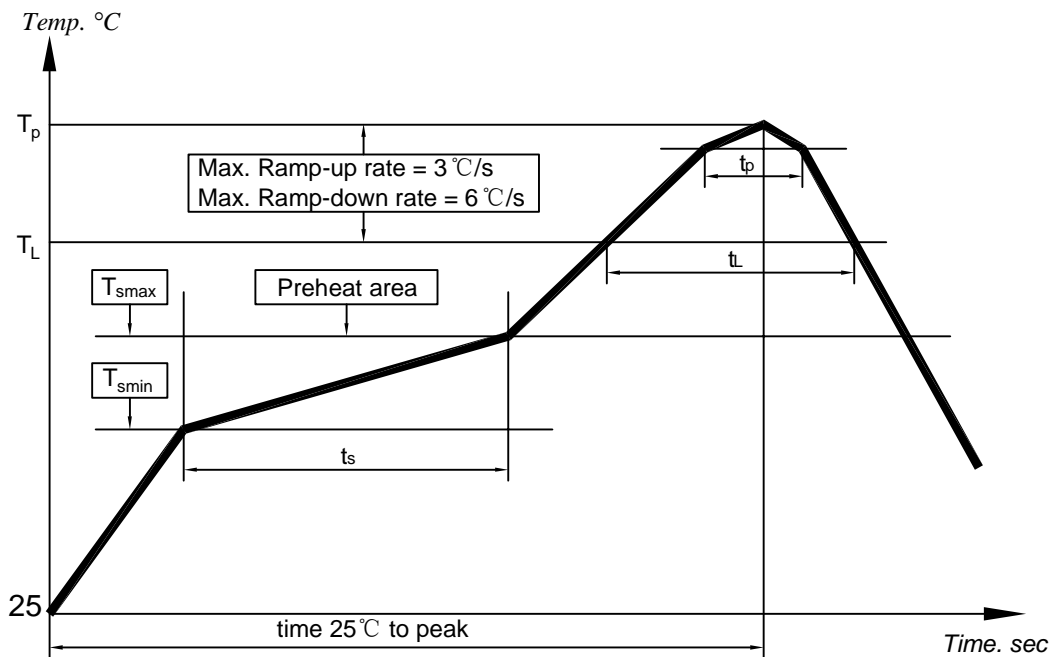

Key Features of The Profile:

Average Ramp-up rate(T_{smax} to T_p)	3°C/s max.
Preheat : Temperature Min(T_{smin}) Temperature Max(T_{smax}) Time(T_{smin} to T_{smax})(t_s)	150°C 200°C 60~180s
Time maintained above : Temperature(T_L) Time(t_L)	217°C 60~150s
Peak Temperature(T_p)	260°C
Time within 5°C of actual Peak Temperature(t_p) :	30~40s
Ramp-down rate(T_p to T_{smax})	6°C/s max
Time 25°C to Peak Temperature	8min max

When MEMS MIC is soldered on PCB, the reflow profile is set according to solder paste and the thickness of PCB etc.

12.4 Rework

- (1) 250°C~270°C, maximum 30 sec, Peak temperature 330°C.
- (2) Wind speed: 15L/m.
- (3) It is very important not to put a heatgun over the acoustic port of the microphone.

13 Cautions

13.1 Board Wash Restrictions

It is very important not to wash the PCBA after reflow process, otherwise this could damage the microphone.

13.2 Nozzle Restrictions

It is very important not to be put a nozzle over the acoustic hole of the microphone, otherwise this could damage the microphone.

13.3 Blowing Restrictions

It is very important not to blow the acoustic port of the microphone directly, otherwise this could damage the microphone.

13.4 Ultrasonic Restrictions

It is very important not to use ultrasonic process. otherwise this could damage the microphone.

13.5 Case Adaption to Pressure Restrictions

It is very important not to press the case with a force larger than 2.5kgf, otherwise this would damage the microphone.

14 Output Inspection Standard

Output inspection standard is executed according to <<ISO2859-1:1999>>.

X-ON Electronics

Largest Supplier of Electrical and Electronic Components

Click to view similar products for [MEMS Microphones](#) category:

Click to view products by [Goertek](#) manufacturer:

Other Similar products are found below :

[8103AC8333S25.00000X](#) [ZTS6577](#) [WMM7018ABHD0-3/TR](#) [ZTS6216](#) [S12OT421-012](#) [SD18OB371-041](#) [CMM-2718AT-42108-TR](#)
[S08OT421-024](#) [S18OT381-016](#) [S15OB381-081](#) [S17OT421-038](#) [S15OT421-001](#) [S18OB381-032](#) [SD04OT264-019](#) [IM69D120V01](#)
[GMA2718H09-B38-3P](#) [ZTS6054](#) [ZTS6117H](#) [GMA3325H10-B38-3P](#) [GSA3526H10-B26-4P](#) [GSA4030H10-F26-4P](#) [GSA4737H12-F22-6P](#)
[GSA4030H10-F26-8P](#) [IM70D122V01XTMA1](#) [1007079-1](#) [5000AC-8E-25E0-25.000000X](#) [ICS-40180](#) [ICS-40300](#) [ICS-40618](#) [ICS-43432](#)
[INMP504ACEZ-R7](#) [INMP510ACEZ-R7](#) [3807ACTC3-33EG-8.19200](#) [501AAA27M0000CAF](#) [SIT9120AC-2C2-25E125.000000](#) [SIT9120AC-](#)
[2C2-25E200.000000](#) [SPU0410LR5H-QB](#) [9120AI-2C3-25E100.0000](#) [8002AI-13-33E16.00000](#) [5001AI-2D-18N0-20.000000](#) [UC2000-30GM-](#)
[IUR2-V15](#) [MM034202-1](#) [ICS-41350](#) [ICS-40619](#) [ICS-52000](#) [SPW0442HR5H-1](#) [MM042602-5](#) [MM033802-1](#) [ICS-43434](#) [ASFLM2-](#)
[28.224MHZ-LR-T](#)