

## Description

Features		
$V_{DSS}$	$R_{DS(ON)}$ @ 10V(Typ)	$I_D$
200V	0.49 $\Omega$	5A

- Fast switching
- 100% avalanche tested
- Improved dv/dt capability

**Application**

- DC Motor Control and Class D Amplifier
- Uninterruptible Power Supply (UPS)
- Automotive

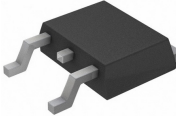

TO-252



TO-251

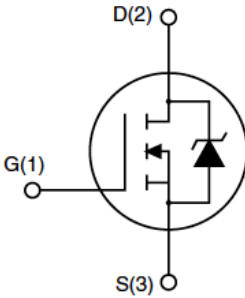

## Absolute Maximum Ratings $T_C=25^\circ\text{C}$ unless otherwise specified

Symbol	Parameter		Max.	Units
			TO-251/TO-252	
$V_{DSS}$	Drain-Source Voltage		200	V
$V_{GSS}$	Gate-Source Voltage		$\pm 30$	V
$I_D$	Continuous Drain Current	$T_C = 25^\circ\text{C}$	5	A
		$T_C = 100^\circ\text{C}$	3.24	A
$I_{DM}$	Pulsed Drain Current <sup>note1</sup>		20	A
$E_{AS}$	Single Pulsed Avalanche Energy <sup>note2</sup>		125	mJ
dv/dt	Peak Diode Recovery Energy <sup>note3</sup>		5	V/ns
$P_D$	Power Dissipation	$T_C = 25^\circ\text{C}$	78	W
	Linear Derating Factor	$T_C > 25^\circ\text{C}$	0.625	W/ $^\circ\text{C}$
$R_{\theta JC}$	Thermal Resistance, Junction to Case		1.6	$^\circ\text{C}/\text{W}$
$T_J, T_{STG}$	Operating and Storage Temperature Range		-55 to +150	$^\circ\text{C}$

\*Drain current limited by maximum junction temperature

## Electrical Characteristics $T_C=25^\circ\text{C}$ unless otherwise specified

Symbol	Parameter	Test Condition	Min.	Typ.	Max.	Units
<b>Off Characteristics</b>						
$V_{(BR)DSS}$	Drain-Source Breakdown Voltage	$V_{GS} = 0V, I_D = 250\mu A$	200	-	-	V
$\Delta V_{(BR)DSS} / \Delta T_J$	Breakdown Voltage Temperature Coefficient	Reference to $25^\circ\text{C}$ , $I_D = 250\mu A$	-	0.25	-	$V/^\circ\text{C}$
$I_{DSS}$	Zero Gate Voltage Drain Current	$V_{DS} = 200V, V_{GS} = 0V$	-	-	1	$\mu A$
		$V_{DS} = 160V, T_C = 125^\circ\text{C}$	-	-	10	$\mu A$
$I_{GSS}$	Gate to Body Leakage Current	$V_{DS} = 0V, V_{GS} = \pm 30V$	-	-	$\pm 100$	nA
<b>On Characteristics</b>						
$V_{GS(th)}$	Gate Threshold Voltage <sup>note4</sup>	$V_{DS} = V_{GS}, I_D = 250\mu A$	1	1.9	3	V
$R_{DS(on)}$	Static Drain-Source On-Resistance	$V_{GS} = 10V, I_D = 2.5A$	-	0.49	0.58	$\Omega$
$g_{FS}$	Forward Transconductance	$V_{DS} = 30V, I_D = 2.5A$	-	5.2	-	S
<b>Dynamic Characteristics</b>						
$C_{iss}$	Input Capacitance	$V_{DS} = 25V, V_{GS} = 0V,$ $f = 1.0\text{MHz}$	-	255	-	pF
$C_{oss}$	Output Capacitance		-	30.2	-	pF
$C_{rss}$	Reverse Transfer Capacitance		-	2.3	-	pF
$Q_g$	Total Gate Charge	$V_{DD} = 160V, I_D = 5A,$ $V_{GS} = 10V$	-	10.8	-	nC
$Q_{gs}$	Gate-Source Charge		-	1.7	-	nC
$Q_{gd}$	Gate-Drain("Miller") Charge		-	3.1	-	nC
<b>Switching Characteristics</b>						
$t_{d(on)}$	Turn-On Delay Time	$V_{DD} = 100V, I_D = 5A,$ $R_G = 10\Omega, V_{GS} = 10V$	-	7.33	-	ns
$t_r$	Turn-On Rise Time		-	10.7	-	ns
$t_{d(off)}$	Turn-Off Delay Time		-	18.2	-	ns
$t_f$	Turn-Off Fall Time		-	11.9	-	ns
<b>Drain-Source Diode Characteristics and Maximum Ratings</b>						
$I_S$	Maximum Continuous Drain to Source Diode Forward Current	-	-	5	-	A
$I_{SM}$	Maximum Pulsed Drain to Source Diode Forward Current	-	-	20	-	A
$V_{SD}$	Drain to Source Diode Forward Voltage	$V_{GS} = 0V, I_S = 5A$	-	-	1.4	V
$t_{rr}$	Reverse Recovery Time	$V_{GS} = 0V, I_F = 5A,$ $di/dt = 100A/\mu s$	-	125.5	-	ns
$Q_{rr}$	Reverse Recovery Charge		-	357	-	nC

Notes:

1. Repetitive Rating: Pulse width limited by maximum junction temperature
2.  $L = 10\text{mH}, I_{AS} = 5A, V_{DD} = 50V, R_G = 25\Omega$ , Starting  $T_J = 25^\circ\text{C}$
3.  $I_{SD} \leq 5A, di/dt \leq 200A/\mu s, V_{DD} \leq B_{VDSS}$ , Starting  $T_J = 25^\circ\text{C}$
4. Pulse width  $\leq 300\mu s$ ; duty cycle  $\leq 2\%$ .

Typical Performance Characteristics

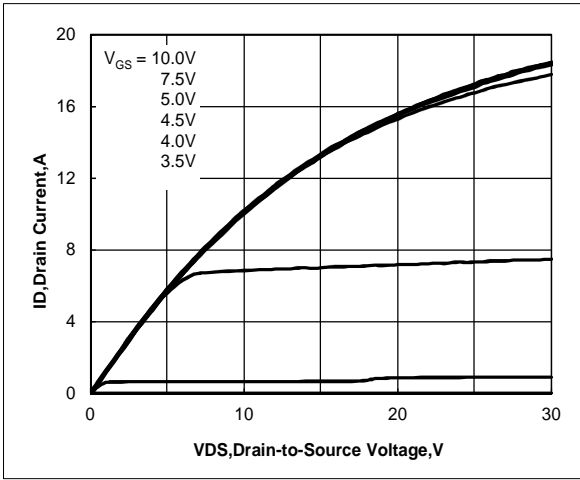

Figure 1. Output Characteristics

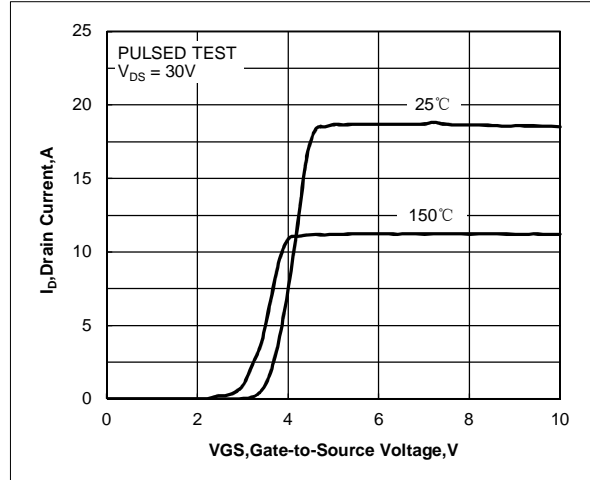

Figure 2. Transfer Characteristics

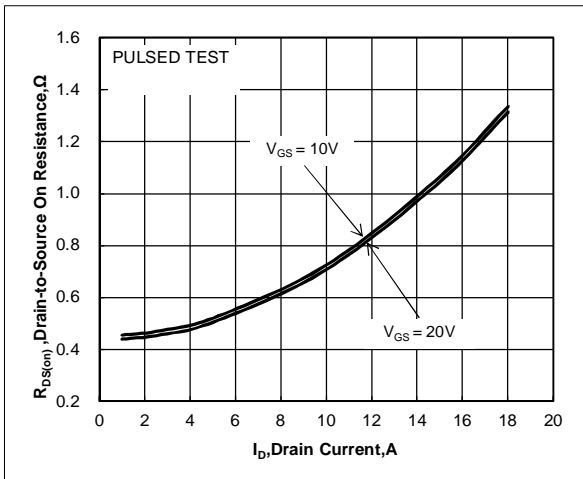

Figure 3. Drain-to-Source On Resistance vs. Drain Current and Gate Voltage

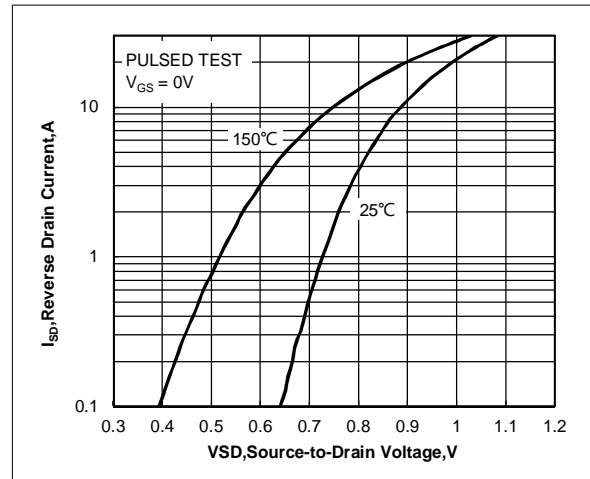

Figure 4. Body Diode Forward Voltage vs. Source Current and Temperature

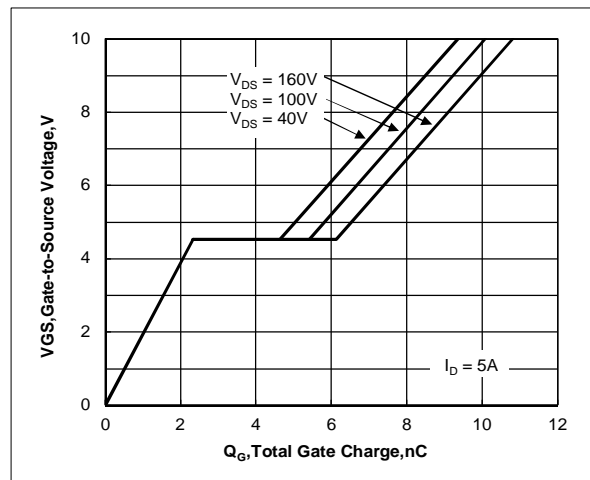
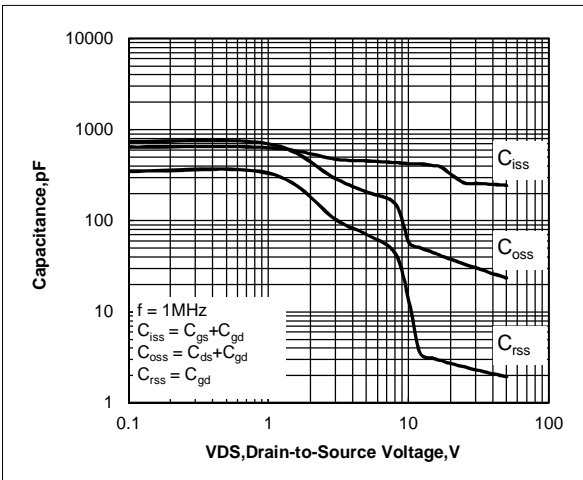

Figure 5. Capacitance Characteristics

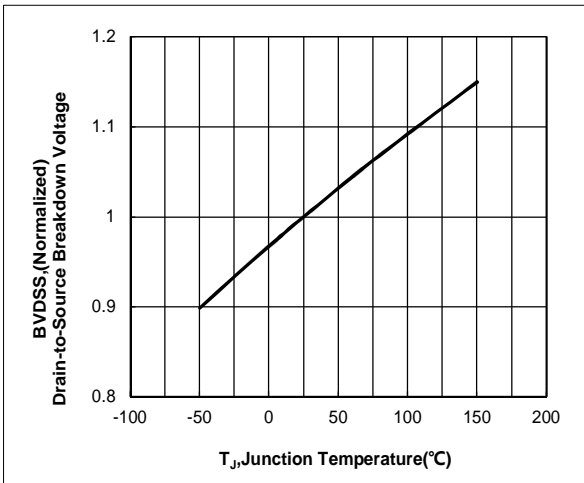

Figure 7. Normalized Breakdown Voltage vs. Junction Temperature

Figure 6. Gate Charge Characteristics

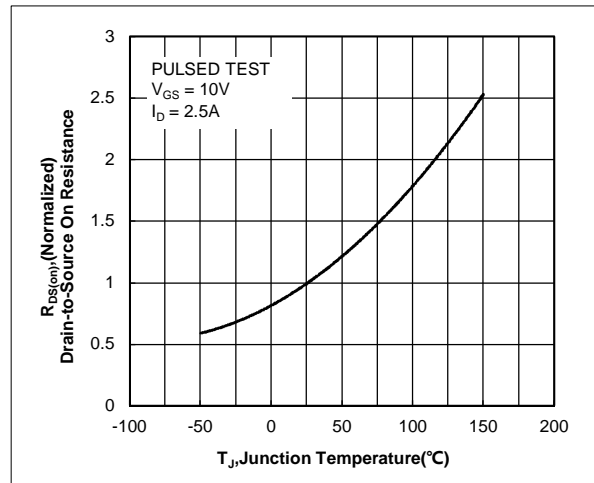

Figure 8. Normalized On Resistance vs. Junction Temperature

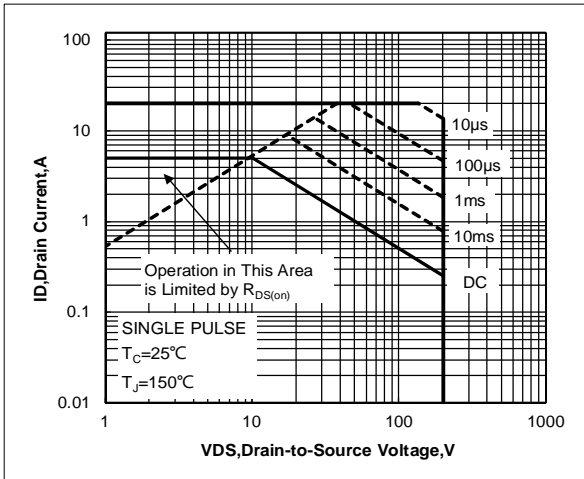

Figure 9. Maximum Safe Operating Area for RU5N20A

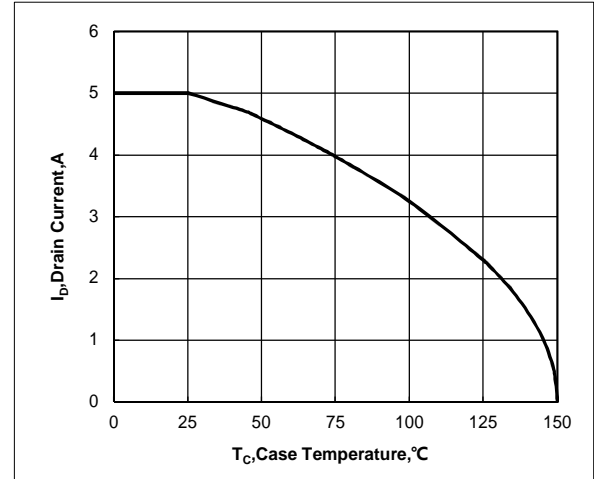

Figure 10. Maximum Continuous Drain Current vs. Case Temperature

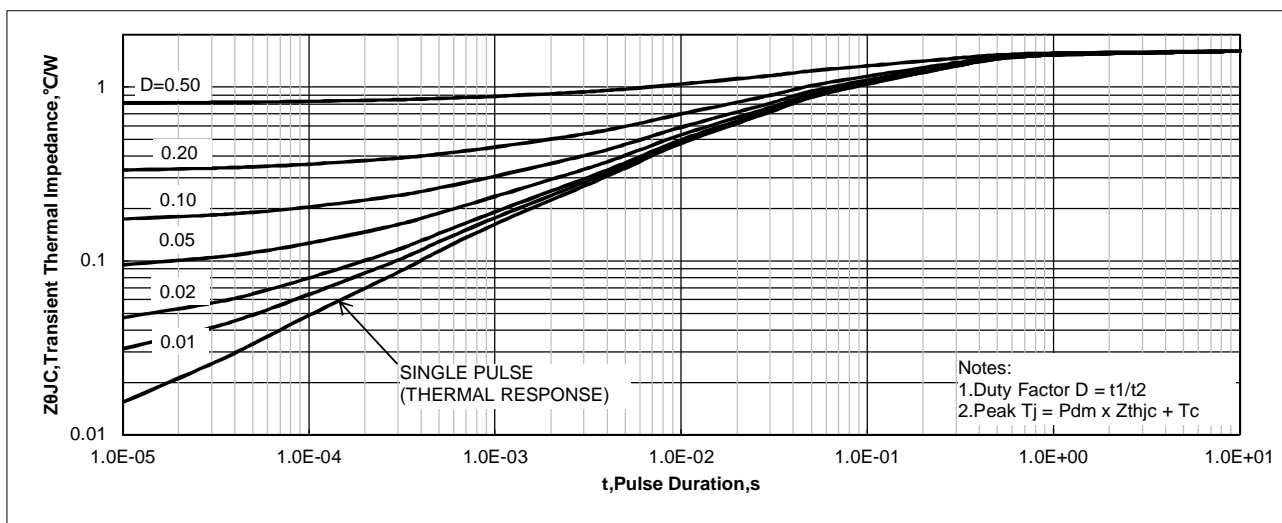

Figure 11. Maximum Effective Transient Thermal Impedance, Junction-to-Case for RU5N20A

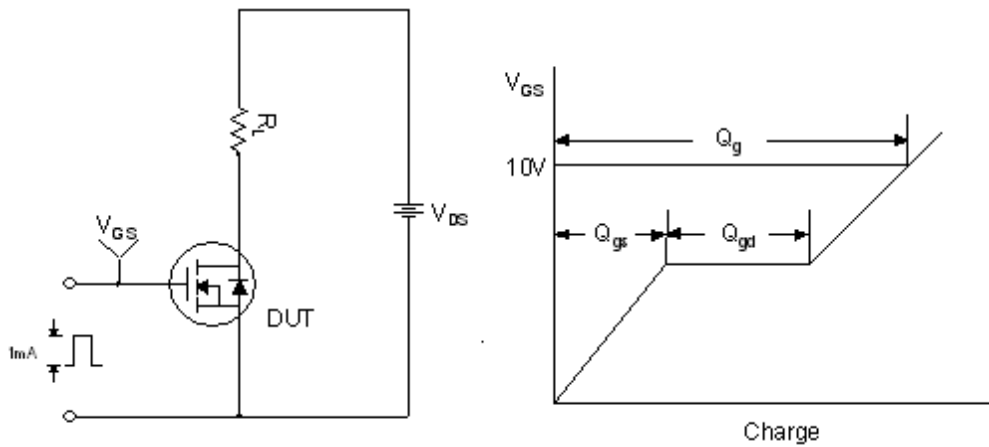

Figure 12. Gate Charge Test Circuit & Waveform

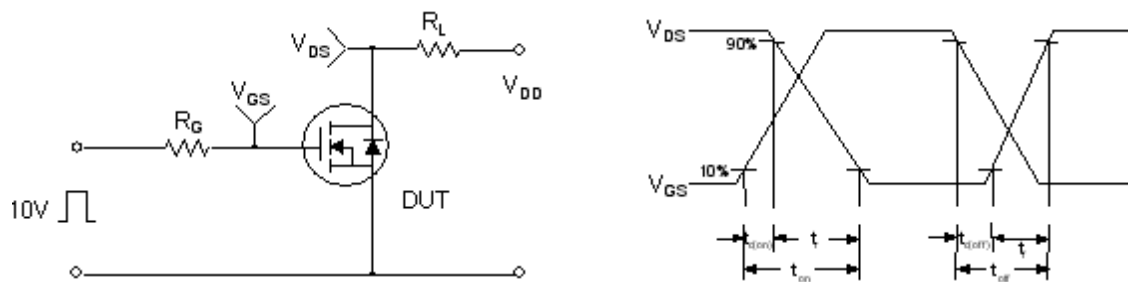

Figure 13. Resistive Switching Test Circuit & Waveforms

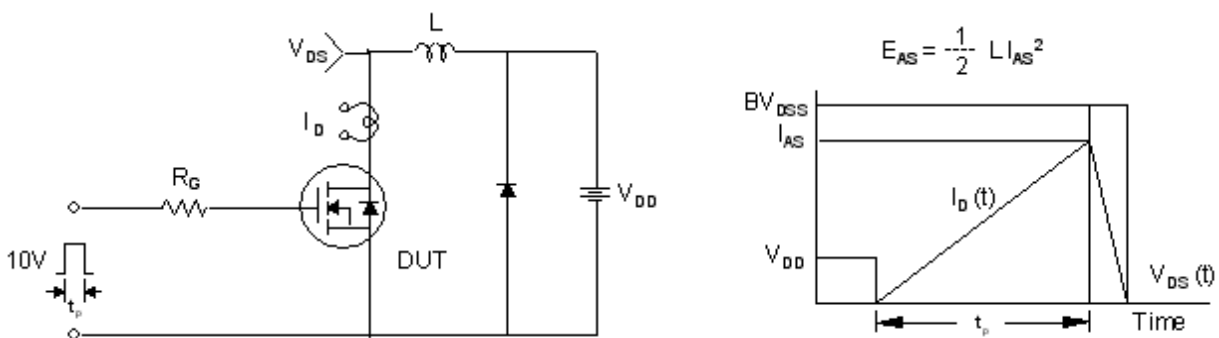

Figure 14. Unclamped Inductive Switching Test Circuit & Waveforms

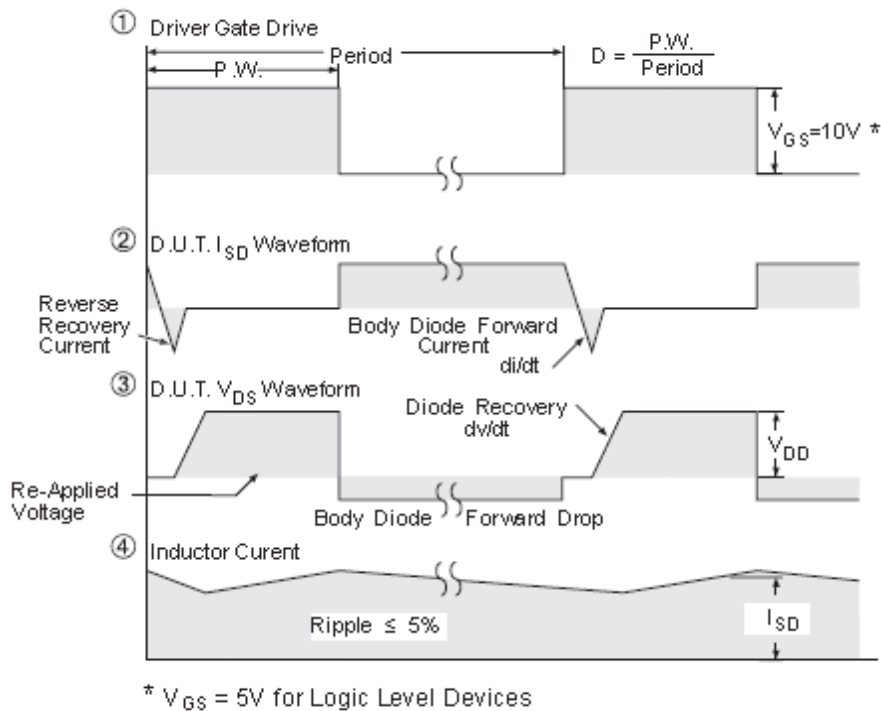
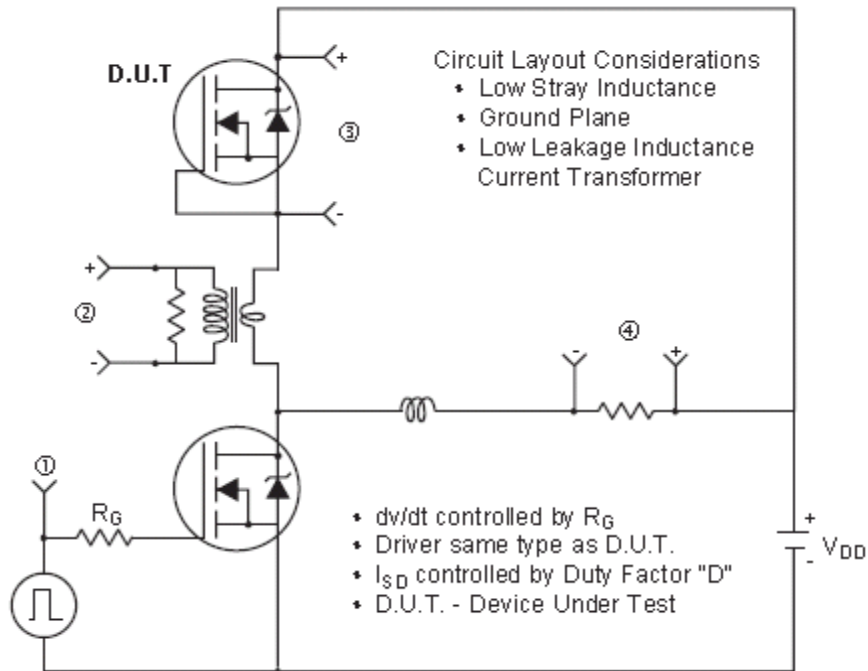

Figure 15. Peak Diode Recovery  $dv/dt$  Test Circuit & Waveforms (For N-channel)

## X-ON Electronics

Largest Supplier of Electrical and Electronic Components

*Click to view similar products for [MOSFET](#) category:*

*Click to view products by [GOFORD](#) manufacturer:*

Other Similar products are found below :

[614233C](#) [648584F](#) [FDPF9N50NZ](#) [IRFD120](#) [IRFF430](#) [JANTX2N5237](#) [2N7000](#) [FCA20N60\\_F109](#) [FDZ595PZ](#) [2SK2267\(Q\)](#) [2SK2545\(Q,T\)](#)  
[405094E](#) [423220D](#) [MIC4420CM-TR](#) [VN1206L](#) [614234A](#) [715780A](#) [SSM6J414TU,LF\(T](#) [751625C](#) [PSMN4R2-30MLD](#)  
[TK31J60W5,S1VQ\(O](#) [2SK2614\(TE16L1,Q\)](#) [DMN1017UCP3-7](#) [EFC2J004NUZTDG](#) [FCAB21350L1](#) [P85W28HP2F-7071](#) [DMN1053UCP4-7](#)  
[NTE2384](#) [NTE2969](#) [NTE6400A](#) [DMN61D9UWQ-13](#) [US6M2GTR](#) [DMN31D5UDJ-7](#) [SSM6P54TU,LF](#) [DMP22D4UFO-7B](#)  
[IPS60R3K4CEAKMA1](#) [DMN1006UCA6-7](#) [DMN16M9UCA6-7](#) [STF5N65M6](#) [STU5N65M6](#) [C3M0021120D](#) [DMN13M9UCA6-7](#)  
[BSS340NWH6327XTSA1](#) [MCM3400A-TP](#) [DMTH10H4M6SPS-13](#) [IPS60R1K0PFD7SAKMA1](#) [IPS60R360PFD7SAKMA1](#)  
[IPS60R600PFD7SAKMA1](#) [IPS60R210PFD7SAKMA1](#) [DMN2990UFB-7B](#)