

General Description

The G1003B uses advanced trench technology to provide excellent $R_{DS(ON)}$, low gate charge and operation with gate voltages as low as 4.5V. This device is suitable for use as a load switch or in PWM applications.

General Features

- | V_{DS} | $R_{DS(ON)}$
@10V (Typ) | $R_{DS(ON)}$
@4.5V(Typ) | I_D |
|----------|----------------------------|----------------------------|-------|
| 100V | 135m Ω | 145m Ω | 5 A |

- High Power and current handing capability
- RoHS Compliant
- Surface Mount Package

Application

- PWM applications
- Load switch
- Power management

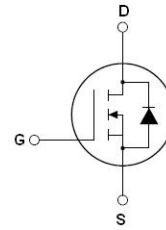

Schematic Diagram

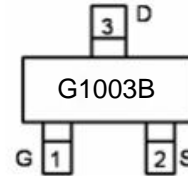

Marking and pin Assignment

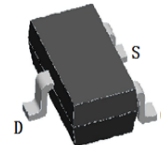

SOT-23

Ordering Information

Part Number	Marking	Case	Packaging
G1003B-23	G1003B	SOT-23-3L	3000pcs/Reel

Table 1. Absolute Maximum Ratings ($T_A=25^\circ\text{C}$)

Symbol	Parameter	Value	Unit
V_{DS}	Drain-Source Voltage ($V_{GS}=0V$)	100	V
V_{GS}	Gate-Source Voltage ($V_{DS}=0V$)	± 25	V
I_D	Drain Current-Continuous($T_c=25^\circ\text{C}$)	5	A
	Drain Current-Continuous($T_c=100^\circ\text{C}$)	1.8	A
$I_{DM (pluse)}$	Drain Current-Continuous@ Current-Pulsed (Note 1)	12	A
P_D	Maximum Power Dissipation	3.3	W
T_J, T_{STG}	Operating Junction and Storage Temperature Range	-55 To 150	$^\circ\text{C}$

Notes 1.Repetitive Rating: Pulse width limited by maximum junction temperature

Table 2. Thermal Characteristic

Symbol	Parameter	Typ	Value	Unit
$R_{\theta JA}$	Thermal Resistance, Junction-to-Ambient	-	37	$^\circ\text{C/W}$

Table 3. Electrical Characteristics (T_A=25°C unless otherwise noted)

Symbol	Parameter	Conditions	Min	Typ	Max	Unit
On/Off States						
B _V DSS	Drain-Source Breakdown Voltage	V _{GS} =0V I _D =250μA	100			V
I _{DSS}	Zero Gate Voltage Drain Current	V _{DS} =100V, V _{GS} =0V			100	μA
I _{GSS}	Gate-Body Leakage Current	V _{GS} =±20V, V _{DS} =0V			±100	nA
V _{GS(th)}	Gate Threshold Voltage	V _{DS} =V _{GS} , I _D =250μA	1	-	3	V
R _{DS(ON)}	Drain-Source On-State Resistance	V _{GS} =10V, I _D =-10A		135	170	mΩ
		V _{GS} =4.5V, I _D =-5A		145	180	mΩ
Dynamic Characteristics						
C _{iss}	Input Capacitance	V _{DS} =25V, V _{GS} =0V, f=1.0MHz		570		pF
C _{oss}	Output Capacitance			25		pF
C _{rss}	Reverse Transfer Capacitance			20		pF
Switching Times						
t _{d(on)}	Turn-on Delay Time	V _{DD} =15V, I _D =1A, R _L =15Ω V _{GS} =10V, R _G =2.5Ω		2.2		nS
t _r	Turn-on Rise Time			3.9		nS
t _{d(off)}	Turn-Off Delay Time			5.8		nS
t _f	Turn-Off Fall Time			1.9		nS
Q _g	Total Gate Charge	V _{DS} =15V, I _D =10A V _{GS} =10V		30		nC
Q _{gs}	Gate-Source Charge			6		nC
Q _{gd}	Gate-Drain Charge			9		nC
Source-Drain Diode Characteristics						
I _{SD}	Source-Drain Current(Body Diode)				12	A
V _{SD}	Forward on Voltage(Notes 1)	V _{GS} =0V, I _S =2A			0.8	V

Notes 1. Repetitive Rating: Pulse width limited by maximum junction temperature.

Switch Time Test Circuit and Switching Waveforms:

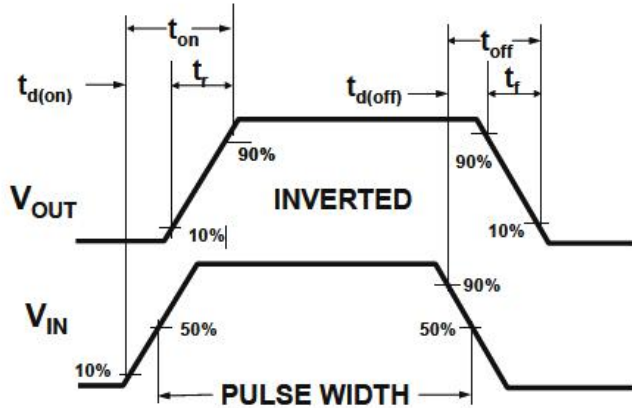
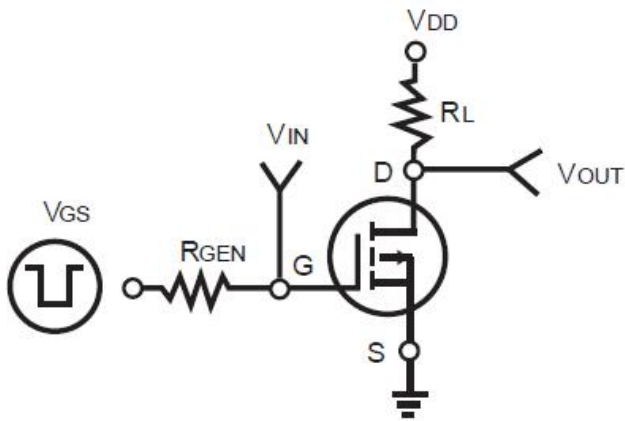

TYPICAL ELECTRICAL AND THERMAL CHARACTERISTICS (Curves)

Figure1. Output Characteristics

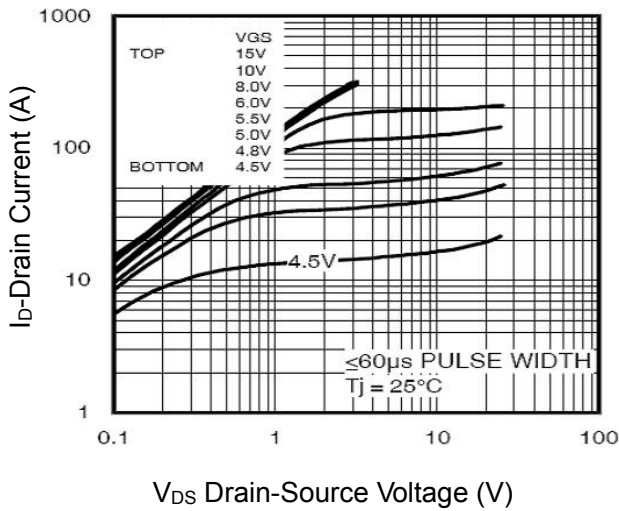

Figure2. Transfer Characteristics

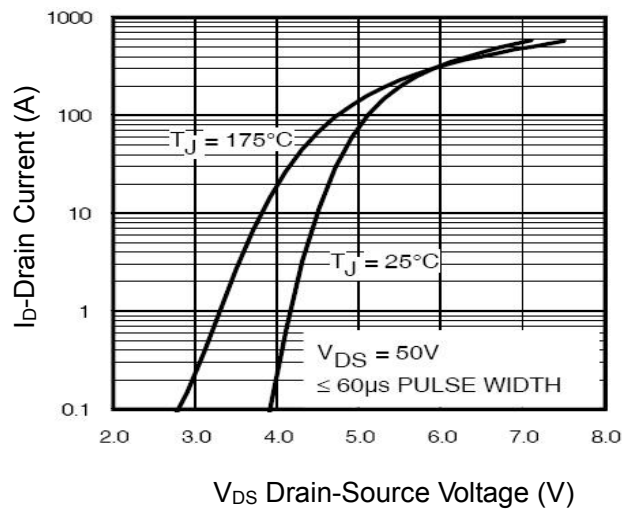

Figure3. BVDSS vs Junction Temperature

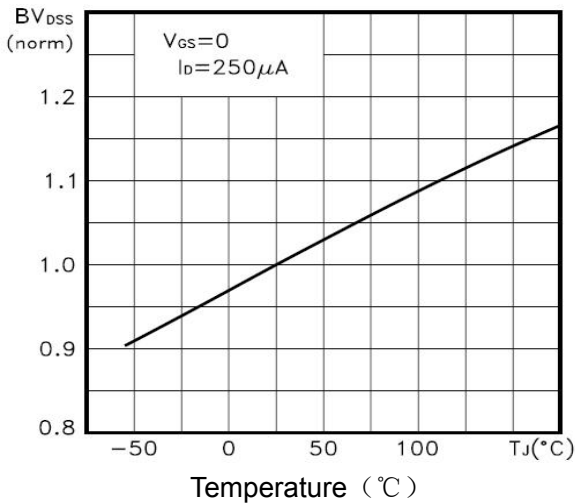

Figure4. ID vs Junction Temperature

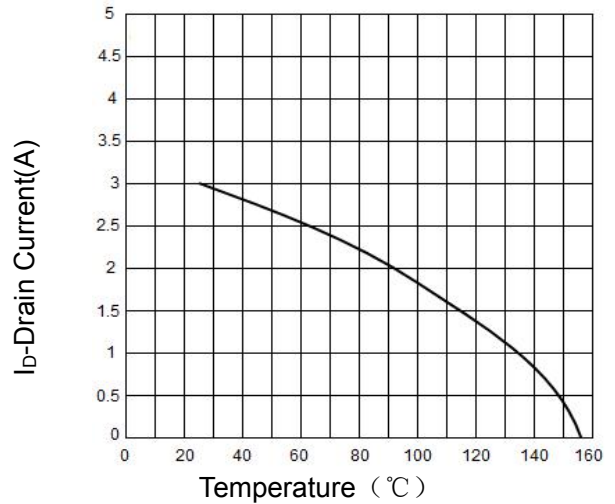

Figure5. VGS(th) vs Junction Temperature

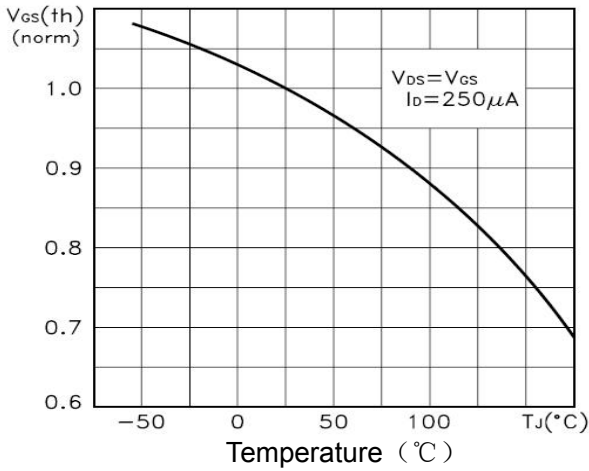

Figure6. Rds(on) Vs Junction Temperature

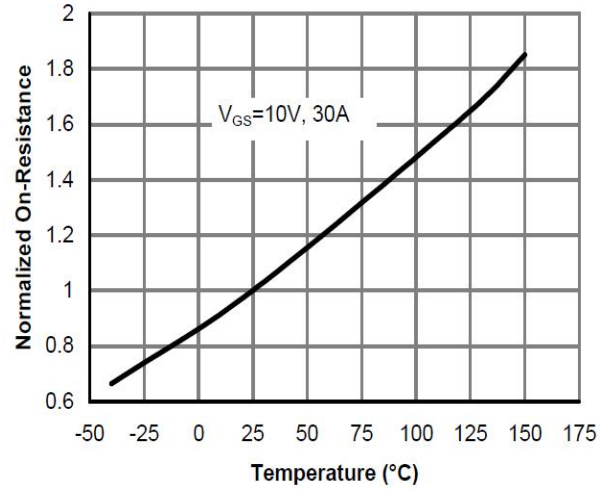

Figure7. Gate Charge

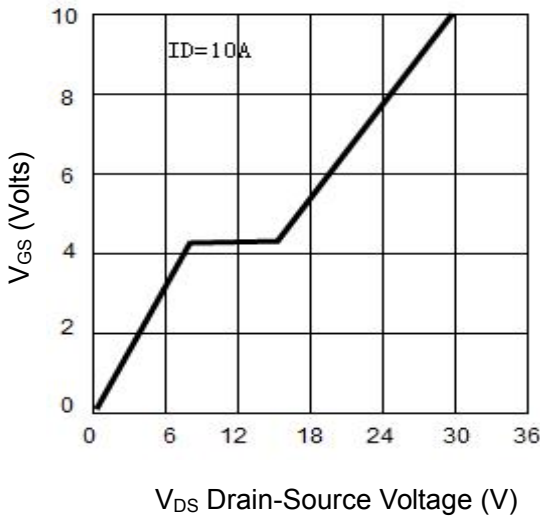

Figure8. Capacitance vs Vds

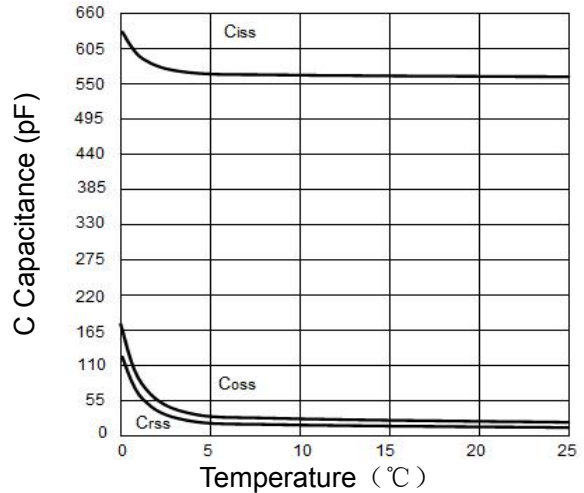

Figure9. Source- Drain Diode Forward

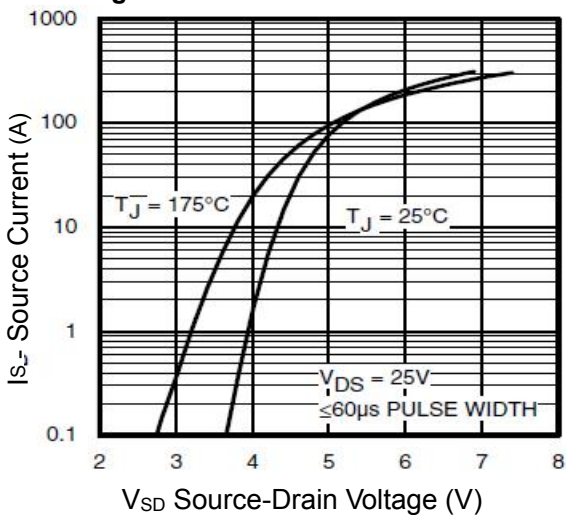

Figure10. Safe Operation Area

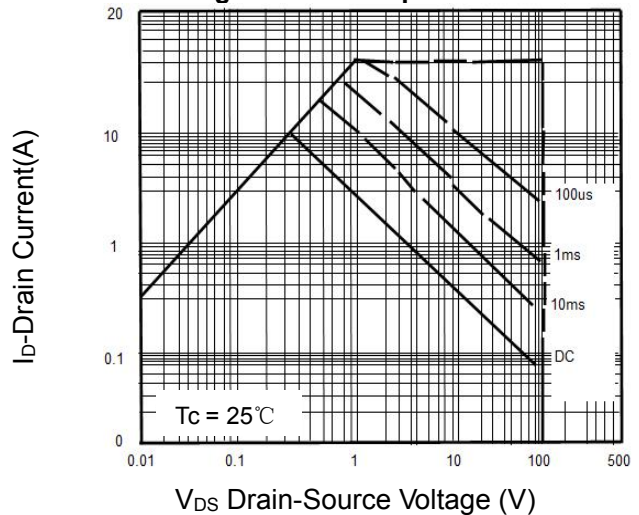
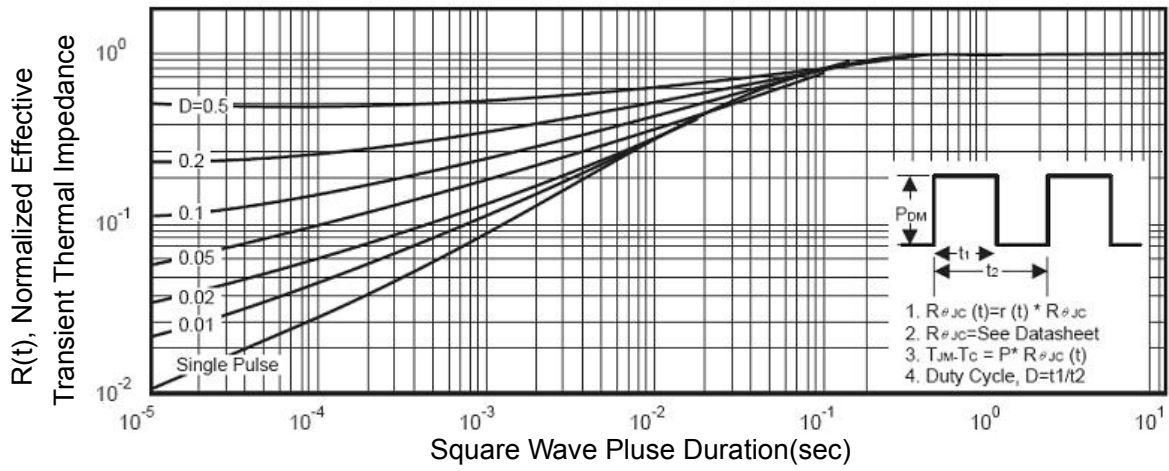
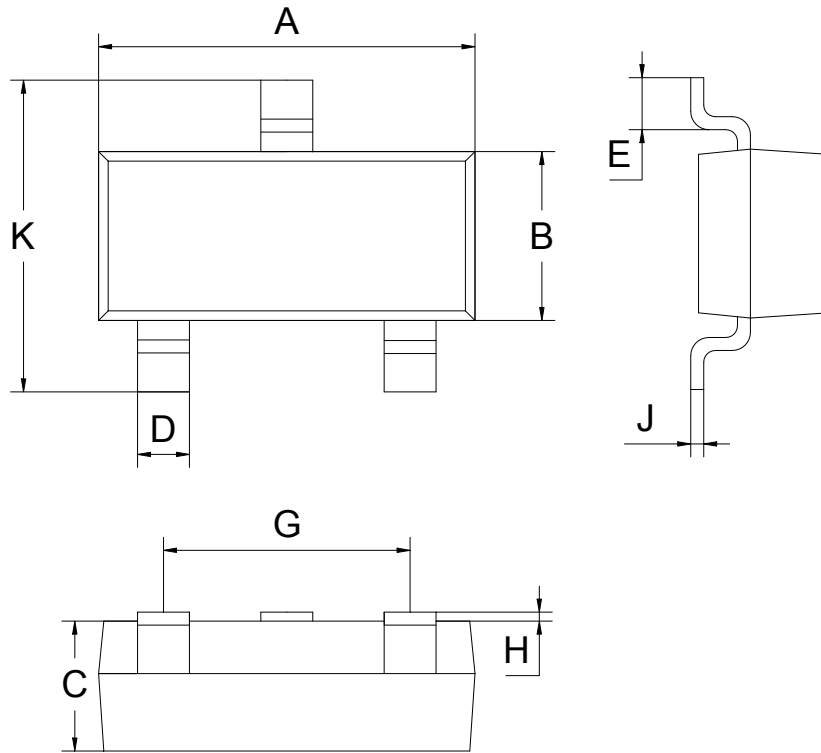

Figure11. Normalized Maximum Transient Thermal Impedance



SOT-23 Package information



SOT-23-3L			
Dim	MIN	NOM	MAX
A	2.80	2.90	3.00
B	1.50	1.60	1.70
C	1.00	1.10	1.20
D	0.30	0.40	0.50
E	0.25	0.40	0.55
G	1.90		
H	0.00	-	0.10
J	0.047	0.127	0.207
K	2.60	2.80	3.00
All Dimensions in mm			

X-ON Electronics

Largest Supplier of Electrical and Electronic Components

Click to view similar products for [MOSFET](#) category:

Click to view products by [GOFORD](#) manufacturer:

Other Similar products are found below :

[IRFD120](#) [JANTX2N5237](#) [BUK455-60A/B](#) [MIC4420CM-TR](#) [VN1206L](#) [NDP4060](#) [SI4482DY](#) [IPS70R2K0CEAKMA1](#) [SQD23N06-31L-GE3](#)
[TK16J60W,S1VQ\(O](#) [2SK2614\(TE16L1,Q\)](#) [DMN1017UCP3-7](#) [DMN1053UCP4-7](#) [SQJ469EP-T1-GE3](#) [NTE2384](#) [DMC2700UDMQ-7](#)
[DMN2080UCB4-7](#) [DMN61D9UWQ-13](#) [US6M2GTR](#) [DMN31D5UDJ-7](#) [DMP22D4UFO-7B](#) [DMN1006UCA6-7](#) [DMN16M9UCA6-7](#)
[STF5N65M6](#) [IRF40H233XTMA1](#) [STU5N65M6](#) [DMN6022SSD-13](#) [DMN13M9UCA6-7](#) [DMTH10H4M6SPS-13](#) [DMN2990UFB-7B](#)
[IPB80P04P405ATMA2](#) [2N7002W-G](#) [MCAC30N06Y-TP](#) [MCQ7328-TP](#) [BXP7N65D](#) [BXP4N65F](#) [AOL1454G](#) [WMJ80N60C4](#) [BXP2N20L](#)
[BXP2N65D](#) [BXT1150N10J](#) [BXT1700P06M](#) [TSM60NB380CP ROG](#) [RQ7L055BGTCR](#) [DMNH15H110SK3-13](#) [SLF10N65ABV2](#)
[BSO203SP](#) [BSO211P](#) [IPA60R230P6](#) [IPA60R460CE](#)