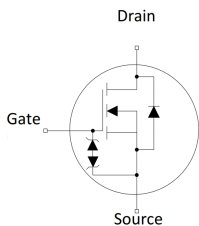
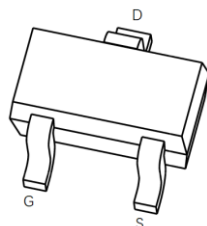

# N-Channel Power MOSFET

<p><b>Description</b></p> <p>The G2N7002X uses advanced trench technology to provide excellent <math>R_{DS(ON)}</math>, low gate charge. It can be used in a wide variety of applications.</p> <p><b>General Features</b></p> <ul style="list-style-type: none"> <li>• <math>V_{DS}</math> 60V</li> <li>• <math>I_D</math> 340mA</li> <li>• <math>R_{DS(ON)}</math>( at <math>V_{GS}=10V</math>) <math>&lt; 5 \Omega</math></li> <li>• <math>R_{DS(ON)}</math>( at <math>V_{GS}=4.5V</math>) <math>&lt; 5.3 \Omega</math></li> <li>• ESD Protected Up to 2.5KV (HBM)</li> <li>• 100% Avalanche Tested</li> <li>• RoHS Compliant</li> </ul> <p><b>Application</b></p> <ul style="list-style-type: none"> <li>• Power switch</li> <li>• DC/DC converters</li> </ul>	 <p><b>Schematic Diagram</b></p>  <p>SOT-523</p>
---	--

Device	Package	Packaging
G2N7002X	SOT-523	3000pcs/Reel

**ABSOLUTE MAXIMUM RATINGS ( $T_a=25^{\circ}C$  unless otherwise noted)**

Parameter	Symbol	Value	Unit
Drain-Source Voltage	$V_{DS}$	60	V
Gate-Source Voltage	$V_{GS}$	$\pm 20$	V
Continuous Drain Current	$I_D$	340	mA
Power Dissipation	$P_D$	0.15	W
Thermal Resistance from Junction to Ambient	$R_{\theta JA}$	833	$^{\circ}C/W$
Junction Temperature	$T_J$	150	$^{\circ}C$
Storage Temperature	$T_{STG}$	-55~ +150	$^{\circ}C$

**Thermal Resistance**

Parameter	Symbol	Value	Unit
Thermal Resistance, Junction-to-Ambient	$R_{thJA}$	833	$^{\circ}C/W$

MOSFET ELECTRICAL CHARACTERISTICS( $T_a=25^{\circ}\text{C}$  unless otherwise noted)

Parameter	Symbol	Test Condition	Min	Type	Max	Unit
<b>Static Characteristics</b>						
Drain-source breakdown voltage	$V_{(BR)DSS}$	$V_{GS} = 0V, I_D = 250\mu A$	60			V
Zero gate voltage drain current	$I_{DSS}$	$V_{DS} = 48V, V_{GS} = 0V$			1	$\mu A$
Gate-body leakage current	$I_{GSS1}$	$V_{GS} = \pm 20V, V_{DS} = 0V$			$\pm 10$	$\mu A$
	$I_{GSS2}$	$V_{GS} = \pm 10V, V_{DS} = 0V$			$\pm 200$	nA
	$I_{GSS2}$	$V_{GS} = \pm 5V, V_{DS} = 0V$			$\pm 100$	nA
Gate threshold voltage*	$V_{GS(th)}$	$V_{DS} = V_{GS}, I_D = 250\mu A$	1	1.4	2.5	V
Drain-source on-resistance*	$R_{DS(on)}$	$V_{GS} = 10V, I_D = 500mA$		1.3	5	$\Omega$
		$V_{GS} = 4.5V, I_D = 200mA$		1.4	5.3	
Recovered charge	$Q_r$	$V_{GS} = 0V, I_S = 300mA, V_R = 25V,$ $di_s/dt = -100A/\mu S$		30		nC
<b>Dynamic characteristics**</b>						
Input Capacitance	$C_{iss}$	$V_{DS} = 10V, V_{GS} = 0V, f = 1MHz$			40	pF
Output Capacitance	$C_{oss}$				30	
Reverse Transfer Capacitance	$C_{rss}$				10	
<b>Switching Characteristics**</b>						
Turn-on delay time	$t_{d(on)}$	$V_{GS} = 10V, V_{DD} = 50V, R_G = 50\Omega$			10	ns
Turn-off delay time	$t_{d(off)}$	$R_{GS} = 50\Omega, R_L = 250\Omega$			15	
Reverse recovery Time	$t_{rr}$	$V_{GS} = 0V, I_S = 300mA, V_R = 25V,$ $di_s/dt = -100A/\mu S$		30		
<b>Source-Drain Diode characteristics</b>						
Diode Forward voltage	$V_{SD}$	$V_{GS} = 0V, I_S = 300mA$		0.97	1.5	V
<b>GATE-SOURCE ZENER DIODE</b>						
Gate-Source Breakdown Voltage	$BV_{GSO}$	$I_{GS} = \pm 1mA$ (Open Drain)	$\pm 21.5$		$\pm 30$	V

**Notes:**

1. Pulse Test: Pulse Width  $\leq 300\mu s$ , Duty Cycle  $\leq 2\%$ .
2. These parameters have no way to verify.

Gate Charge Test Circuit

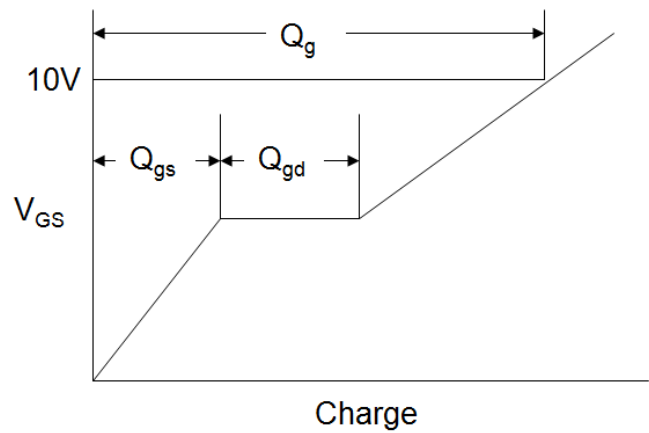
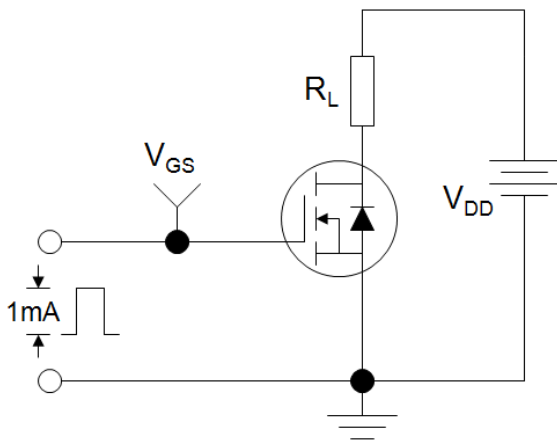

Switch Time Test Circuit



EAS Test Circuit

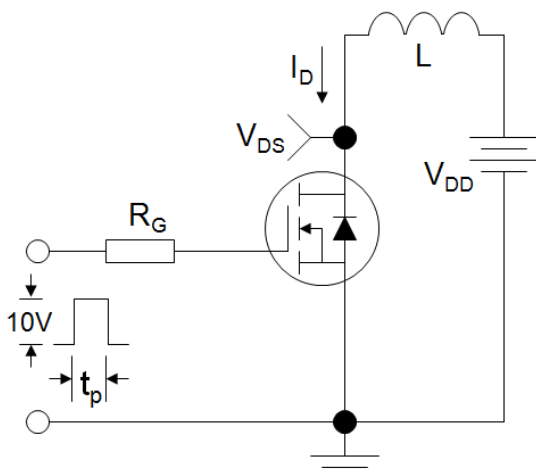

Typical Characteristics

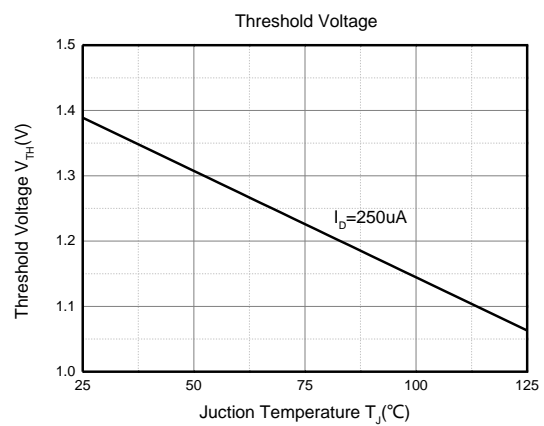
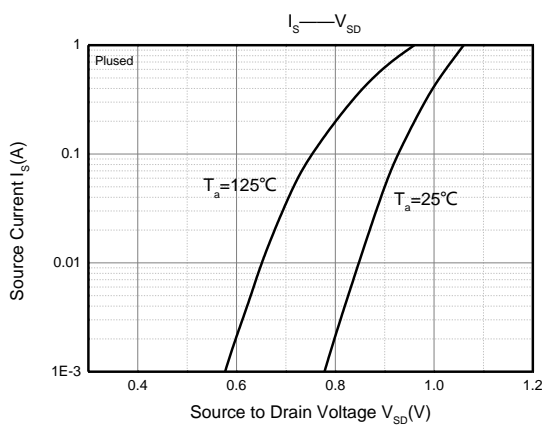
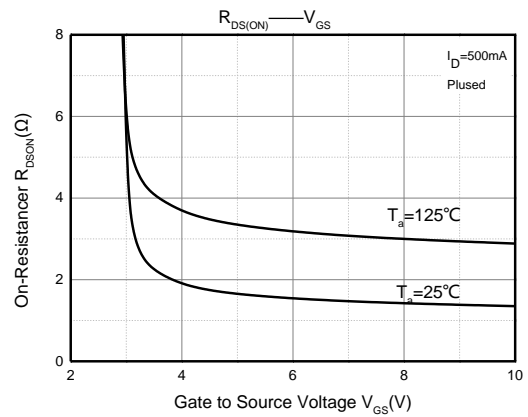
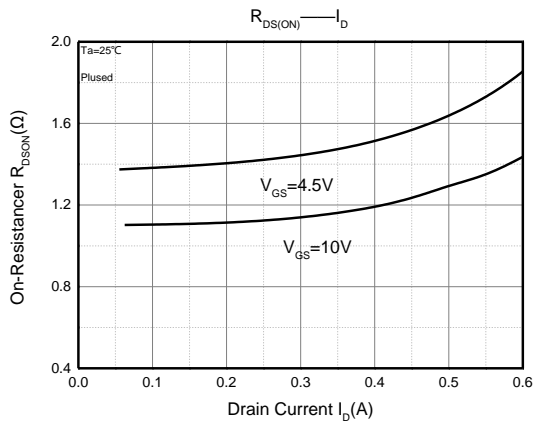
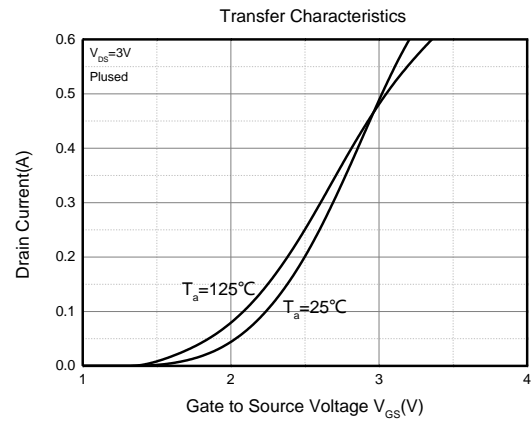
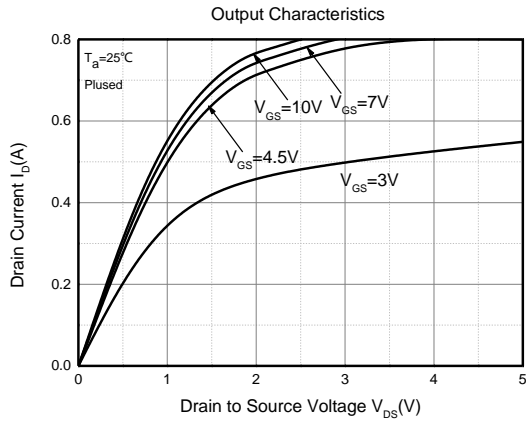

SOT-523 Package Information

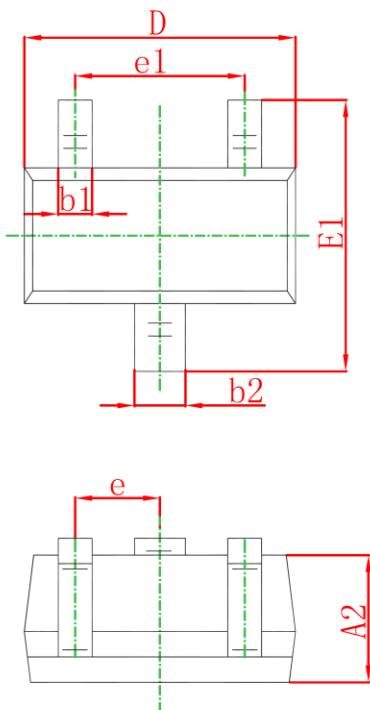

Symbol	Dimensions In Millimeters		Dimensions In Inches	
	Min.	Max.	Min.	Max.
A	0.700	0.900	0.028	0.035
A1	0.000	0.100	0.000	0.004
A2	0.700	0.800	0.028	0.031
b1	0.150	0.250	0.006	0.010
b2	0.250	0.350	0.010	0.014
c	0.100	0.200	0.004	0.008
D	1.500	1.700	0.059	0.067
E	0.700	0.900	0.028	0.035
E1	1.450	1.750	0.057	0.069
e	0.500 TYP.		0.020 TYP.	
e1	0.900	1.100	0.035	0.043
L	0.400 REF.		0.016 REF.	
L1	0.260	0.460	0.010	0.018
θ	0°	8°	0°	8°

## X-ON Electronics

Largest Supplier of Electrical and Electronic Components

*Click to view similar products for [MOSFET](#) category:*

*Click to view products by [GOFORD](#) manufacturer:*

Other Similar products are found below :

[IRFD120](#) [JANTX2N5237](#) [BUK455-60A/B](#) [MIC4420CM-TR](#) [VN1206L](#) [NDP4060](#) [SI4482DY](#) [IPS70R2K0CEAKMA1](#) [SQD23N06-31L-GE3](#)  
[TK16J60W,S1VQ\(O](#) [2SK2614\(TE16L1,Q\)](#) [DMN1017UCP3-7](#) [DMN1053UCP4-7](#) [SQJ469EP-T1-GE3](#) [NTE2384](#) [DMC2700UDMQ-7](#)  
[DMN2080UCB4-7](#) [DMN61D9UWQ-13](#) [US6M2GTR](#) [DMN31D5UDJ-7](#) [DMP22D4UFO-7B](#) [DMN1006UCA6-7](#) [DMN16M9UCA6-7](#)  
[STF5N65M6](#) [IRF40H233XTMA1](#) [STU5N65M6](#) [DMN6022SSD-13](#) [DMN13M9UCA6-7](#) [DMTH10H4M6SPS-13](#) [DMN2990UFB-7B](#)  
[IPB80P04P405ATMA2](#) [2N7002W-G](#) [MCAC30N06Y-TP](#) [MCQ7328-TP](#) [NTMC083NP10M5L](#) [BXP7N65D](#) [BXP4N65F](#) [AOL1454G](#)  
[WMJ80N60C4](#) [BXP2N20L](#) [BXP2N65D](#) [BXT1150N10J](#) [BXT1700P06M](#) [TSM60NB380CP](#) [ROG](#) [RQ7L055BGTGR](#) [DMNH15H110SK3-13](#)  
[SLF10N65ABV2](#) [BSO203SP](#) [BSO211P](#) [IPA60R230P6](#)