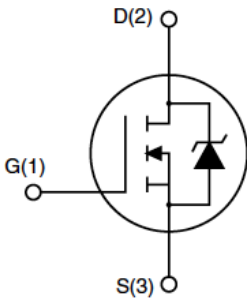
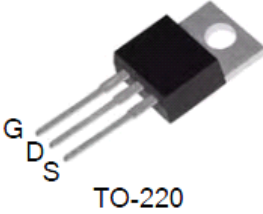

Description

<p>Features</p> <ul style="list-style-type: none"> <table border="1" style="margin-left: 20px; border-collapse: collapse; text-align: center;"> <tr> <td style="padding: 5px;">V_{DSS}</td> <td style="padding: 5px;">$R_{DS(ON)}$ @ 10V (typ)</td> <td style="padding: 5px;">I_D</td> </tr> <tr> <td style="padding: 5px;">55V</td> <td style="padding: 5px;">6.8mΩ</td> <td style="padding: 5px;">110A</td> </tr> </table> Fast switching 100% avalanche tested Improved dv/dt capability RoHS Compliant <p>Application</p> <ul style="list-style-type: none"> UPS High efficiency switch mode power supplies 	V_{DSS}	$R_{DS(ON)}$ @ 10V (typ)	I_D	55V	6.8m Ω	110A	  <p style="text-align: center;">TO-220</p>
V_{DSS}	$R_{DS(ON)}$ @ 10V (typ)	I_D					
55V	6.8m Ω	110A					

Ordering Information

Part Number	Marking	Case	Packaging
G3205	G3205	TO-220	50pcs/Tube

Absolute Maximum Ratings $T_C=25^\circ\text{C}$ unless otherwise specified

Symbol	Parameter	Max.	Units
		TO-220	
V_{DSS}	Drain-Source Voltage	55	V
V_{GSS}	Gate-Source Voltage	± 20	V
I_D	Continuous Drain Current	$T_C = 25^\circ\text{C}$	110 ^{note5}
		$T_C = 100^\circ\text{C}$	80
I_{DM}	Pulsed Drain Current ^{note1}	390	A
I_{AR}	Avalanche Current ^{note1}	60	A
E_{AR}	Repetitive Avalanche Energy ^{note1}	20	mJ
dv/dt	Peak Diode Recovery Energy ^{note3}	5.0	V/ns
P_D	Power Dissipation	$T_C = 25^\circ\text{C}$	200
	Linear Derating Factor	$T_C > 25^\circ\text{C}$	1.3
$R_{\theta JC}$	Thermal Resistance, Junction to Case	0.75	$^\circ\text{C/W}$
T_J, T_{STG}	Operating and Storage Temperature Range	-55 to +175	$^\circ\text{C}$

⁵Drain current limited by maximum junction temperature

Electrical Characteristics $T_C=25^\circ\text{C}$ unless otherwise specified

Symbol	Parameter	Test Condition	Min.	Typ.	Max.	Units
Off Characteristic						
$V_{(BR)DSS}$	Drain-Source Breakdown Voltage	$V_{GS} = 0V, I_D = 250\mu A$	55	-	-	V
$\Delta V_{(BR)DSS} / \Delta T_J$	Breakdown Voltage Temperature Coefficient	Reference to 25°C , $I_D = 250\mu A$	-	0.057	-	$V/^\circ\text{C}$
I_{DSS}	Zero Gate Voltage Drain Current	$V_{DS} = 55V, V_{GS} = 0V$	-	-	1	μA
		$V_{DS} = 44V, T_C = 125^\circ\text{C}$	-	-	10	μA
I_{GSS}	Gate to Body Leakage Current	$V_{DS} = 0V, V_{GS} = \pm 20V$	-	-	± 100	nA
On Characteristics						
$V_{GS(th)}$	Gate Threshold Voltage ^{note4}	$V_{DS} = V_{GS}, I_D = 250\mu A$	2	-	4	V
$R_{DS(on)}$	Static Drain-Source On-Resistance	$V_{GS} = 10V, I_D = 60A$	-	6.8	8.0	$m\Omega$
g_{FS}	Forward Transconductance	$V_{DS} = 20V, I_D = 60A$	45	-	-	S
Dynamic Characteristics						
C_{iss}	Input Capacitance	$V_{DS} = 25V, V_{GS} = 0V,$ $f = 1.0\text{MHz}$	-	3291	-	pF
C_{oss}	Output Capacitance		-	671.5	-	pF
C_{rss}	Reverse Transfer Capacitance		-	112.1	-	pF
Q_g	Total Gate Charge	$V_{DD} = 44V, I_D = 60A,$ $V_{GS} = 10V$	-	112	-	nC
Q_{gs}	Gate-Source Charge		-	23.2	-	nC
Q_{gd}	Gate-Drain("Miller") Charge		-	34.9	-	nC
EAS	Single Pulse Avalanche Energy ^{note2}	$I_{AS} = 20A, L = 5\text{mH}$	-	1000 ^{note6}	267 ^{note7}	mJ
Switching Characteristics						
$t_{d(on)}$	Turn-On Delay Time	$V_{DD} = 28V, I_D = 60A,$ $R_G = 5\Omega, V_{GS} = 10V$	-	19.5	-	ns
t_r	Turn-On Rise Time		-	50.7	-	ns
$t_{d(off)}$	Turn-Off Delay Time		-	55	-	ns
t_f	Turn-Off Fall Time		-	24.6	-	ns
Drain-Source Diode Characteristics and Maximum Ratings						
I_S	Maximum Continuous Drain to Source Diode Forward Current	-	-	110	-	A
I_{SM}	Maximum Pulsed Drain to Source Diode Forward Current	-	-	390	-	A
V_{SD}	Drain to Source Diode Forward Voltage	$V_{GS} = 0V, I_S = 60A$	-	-	1.3	V
t_{rr}	Reverse Recovery Time	$V_{GS} = 0V, I_F = 60A,$ $di/dt = 100A/\mu s$	-	62.3	-	ns
Q_{rr}	Reverse Recovery Charge		-	137	-	nC

Notes:

1. Repetitive Rating: Pulse width limited by maximum junction temperature
2. $L = 5\text{mH}, I_{AS} = 20A, V_{DD} = 50V, R_G = 25\Omega$, Starting $T_J = 25^\circ\text{C}$
3. $I_{SD} \leq 60A, di/dt \leq 200A/\mu s, V_{DD} \leq B_{VDSS}$, Starting $T_J = 25^\circ\text{C}$
4. Pulse width $\leq 300\mu s$; duty cycle $\leq 2\%$.
5. Calculated continuous current based on maximum allowable junction temperature. Package limitation current is 75A.
6. This is a typical value at device destruction and represents operation outside rated limits.
7. This is a calculated value limited to $T_J = 175^\circ\text{C}$.

Typical Performance Characteristics

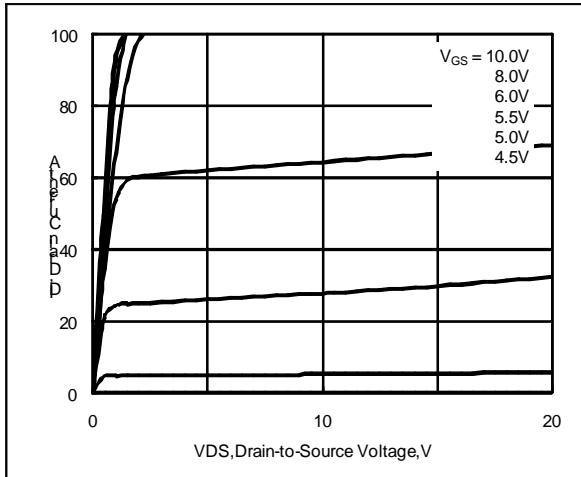

Figure 1. Output Characteristics

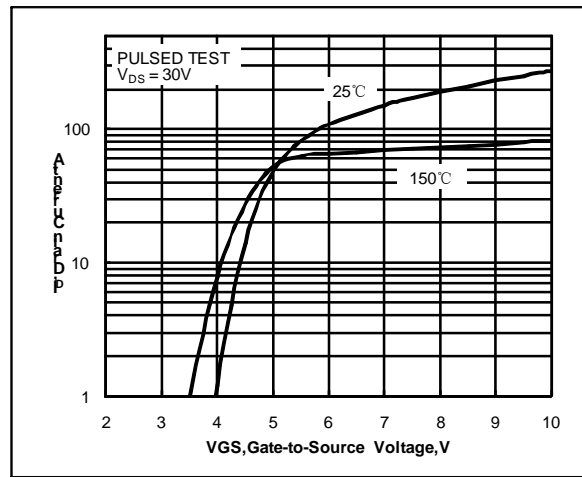

Figure 2. Transfer Characteristics

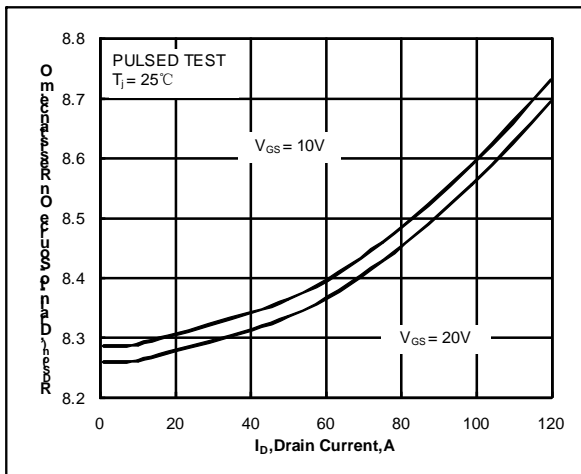

Figure 3. Drain-to-Source On Resistance vs. Drain Current and Gate Voltage

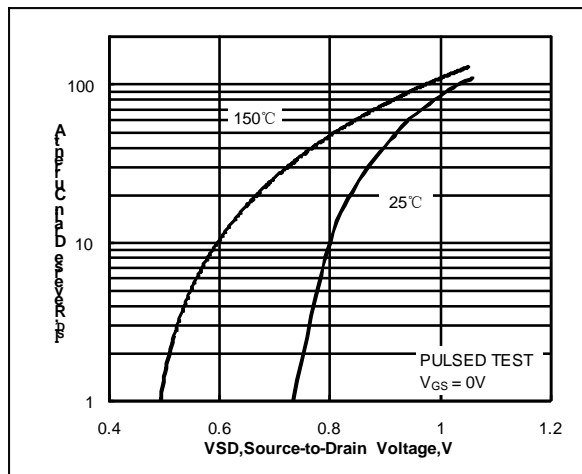

Figure 4. Body Diode Forward Voltage vs. Source Current and Temperature

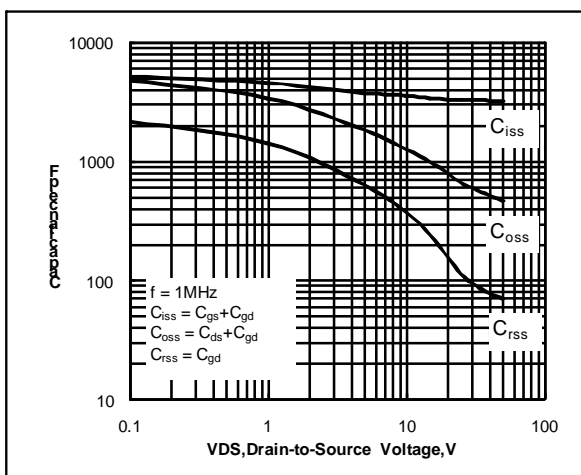

Figure 5. Capacitance Characteristics

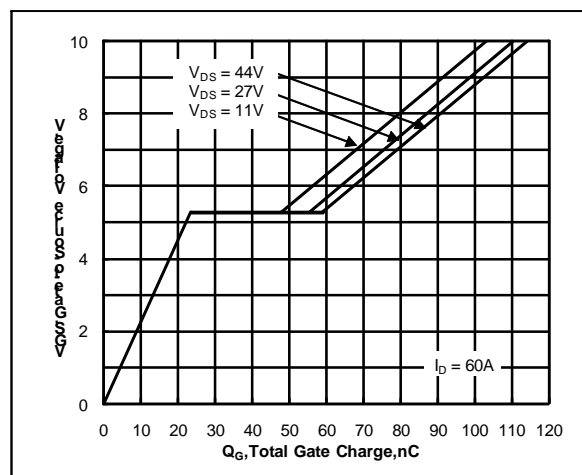

Figure 6. Gate Charge Characteristics

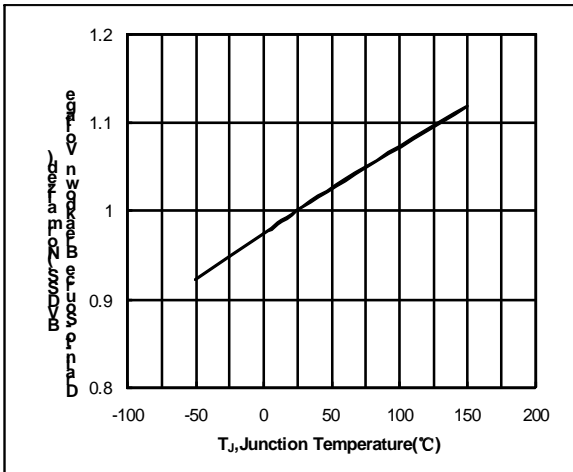

Figure 7. Normalized Breakdown Voltage vs. Junction Temperature

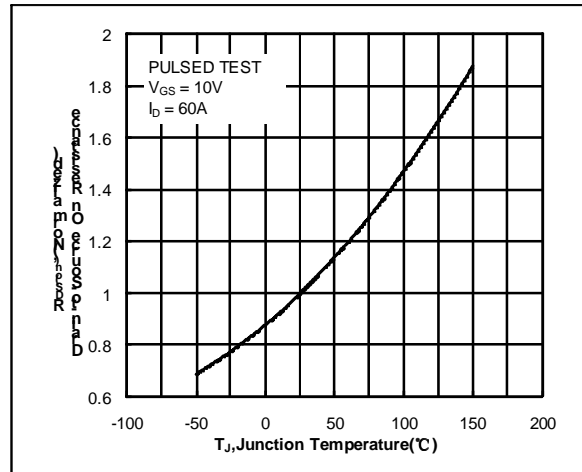

Figure 8. Normalized On Resistance vs. Junction Temperature

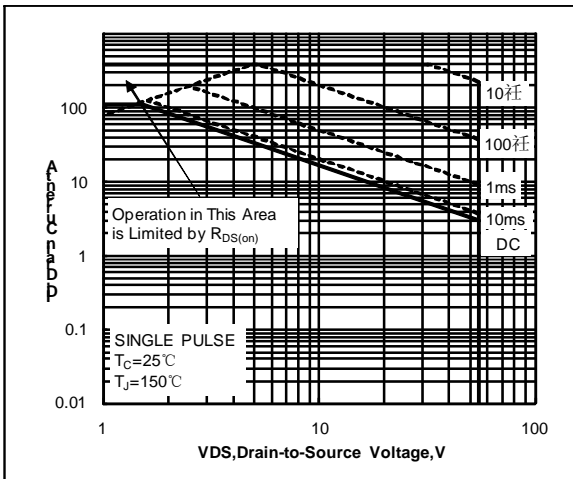

Figure 9. Maximum Safe Operating Area for OP3205B

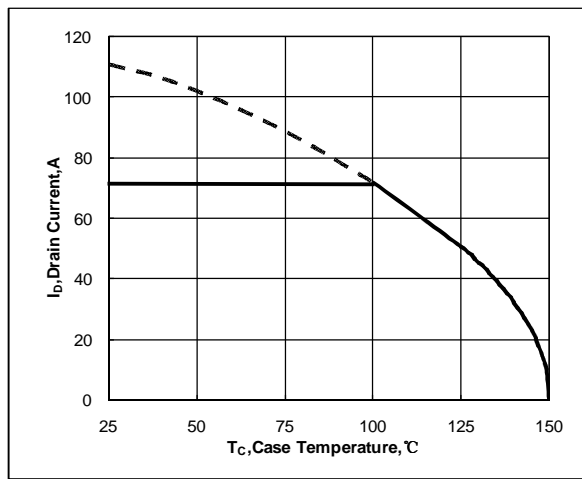

Figure 10. Maximum Continuous Drain Current vs. Case Temperature

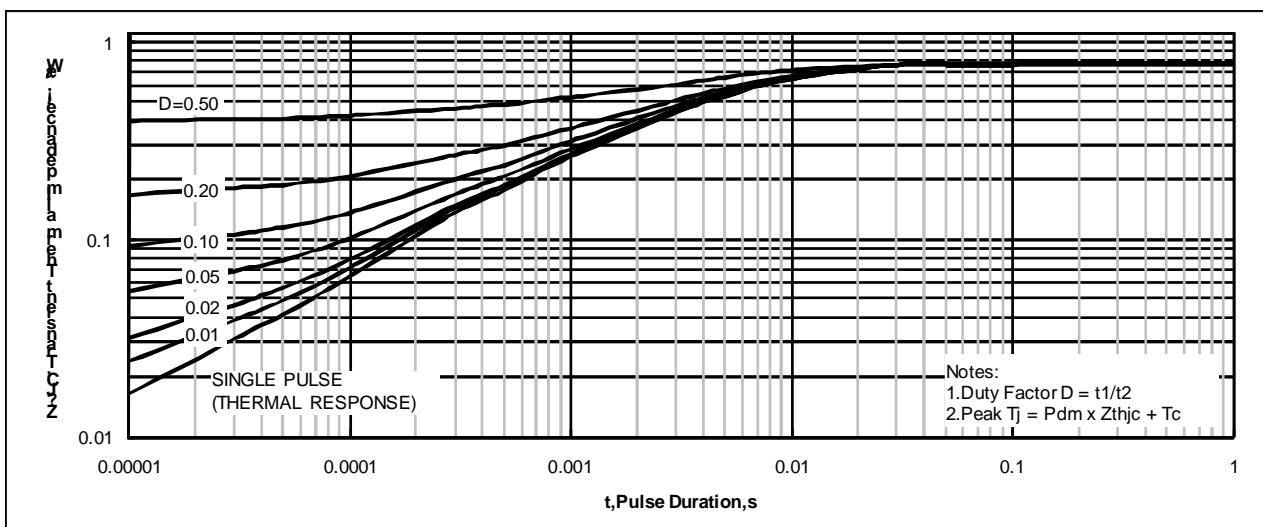

Figure 11. Maximum Effective Transient Thermal Impedance, Junction-to-Case for OP3205B

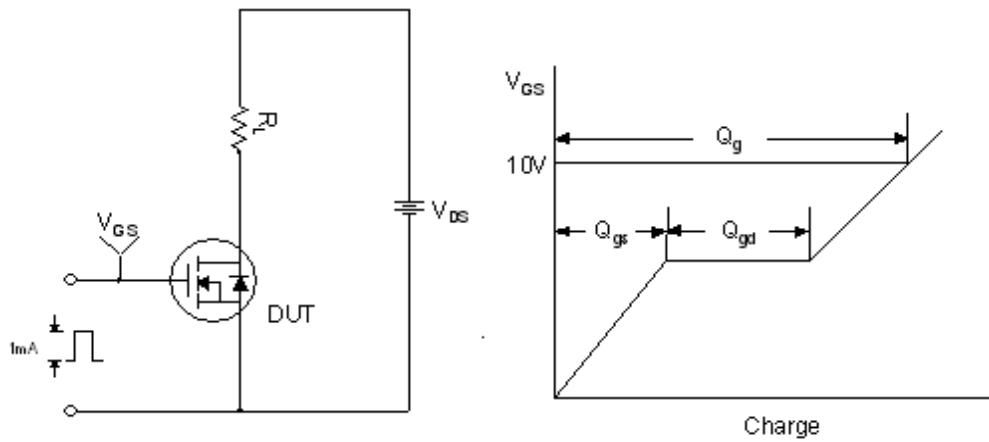

Figure 12. Gate Charge Test Circuit & Waveform

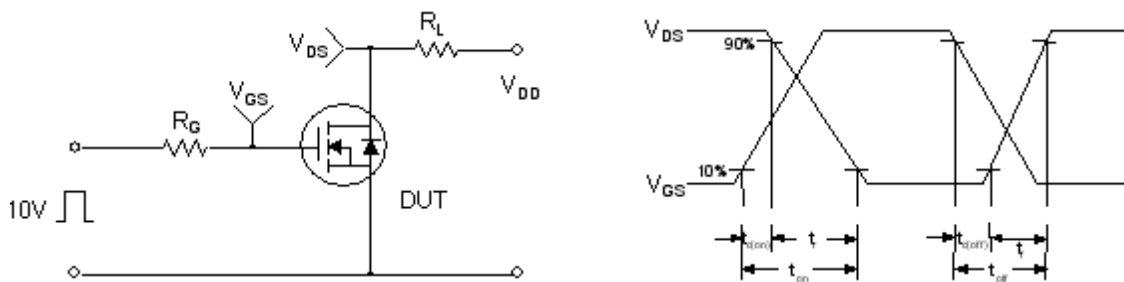

Figure 13. Resistive Switching Test Circuit & Waveforms

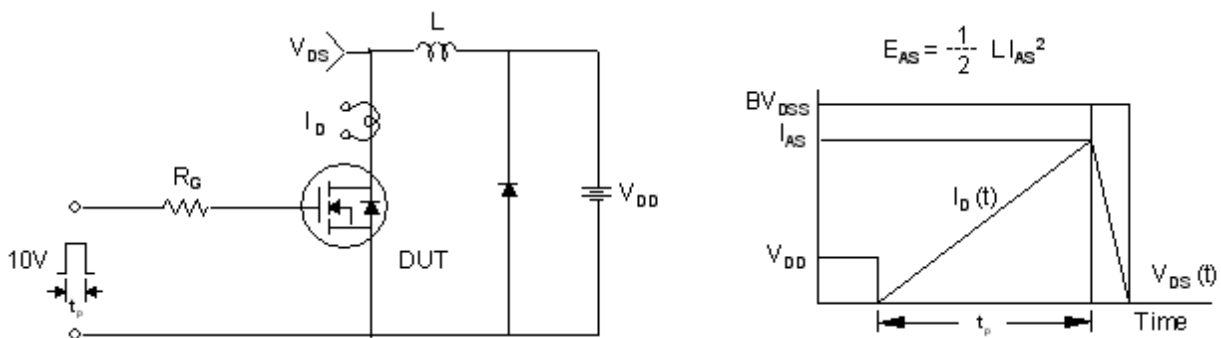

Figure 14. Unclamped Inductive Switching Test Circuit & Waveforms

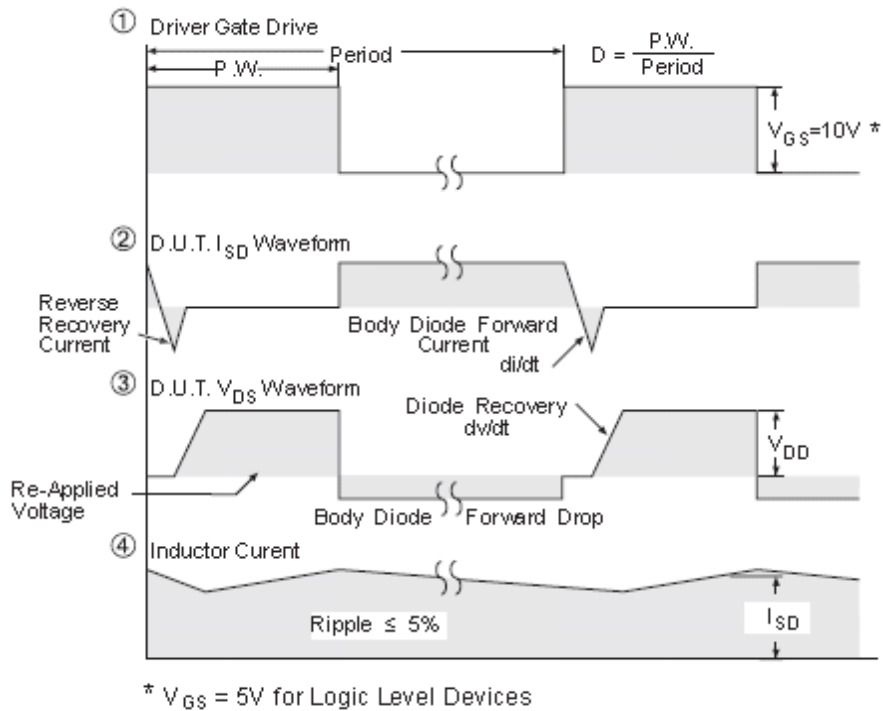
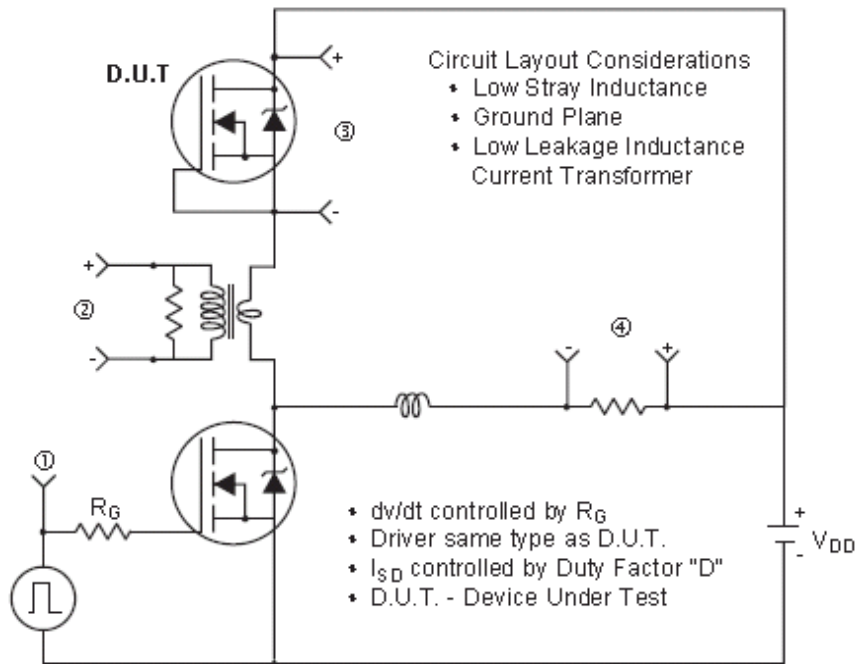
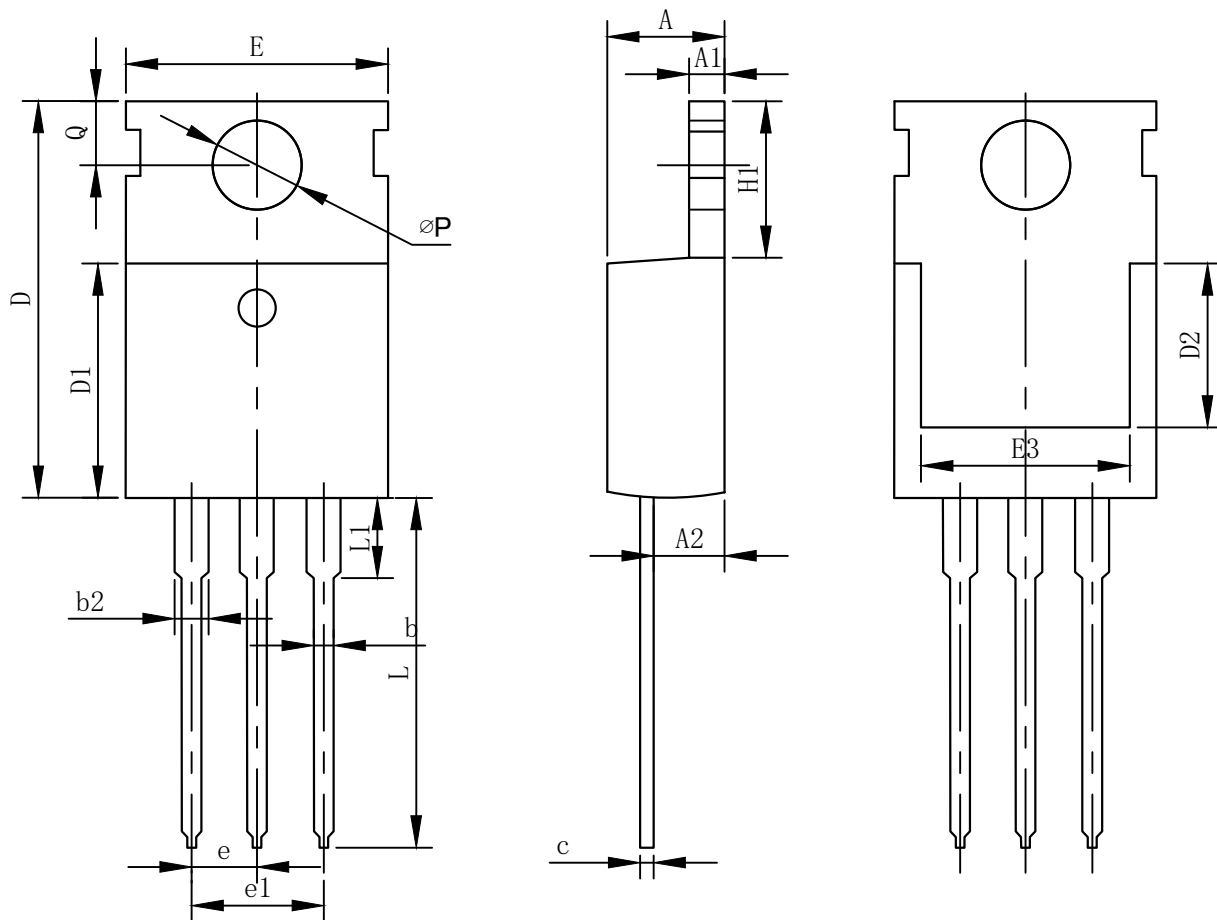

Figure 15. Peak Diode Recovery dv/dt Test Circuit & Waveforms (For N-channel)

TO-220 Package information



COMMON DIMENSIONS

SYMBOL	mm		
	MIN	NOM	MAX
A	4.37	4.57	4.70
A1	1.25	1.30	1.40
A2	2.20	2.40	2.60
b	0.70	0.80	0.95
b2	1.70	1.27	1.47
c	0.45	0.50	0.60
D	15.10	15.60	16.10
D1	8.80	9.10	9.40
D2	5.50	-	-
E	9.70	10.00	10.30
E3	7.00	-	-
e	2.54BSC		
e1	5.08BSC		
H1	6.25	6.50	6.85
L	12.75	13.50	13.80
L1	-	3.10	3.40
∅P	3.40	3.60	3.80
Q	2.60	2.80	3.00

X-ON Electronics

Largest Supplier of Electrical and Electronic Components

Click to view similar products for [MOSFET](#) category:

Click to view products by [GOFORD](#) manufacturer:

Other Similar products are found below :

[614233C](#) [648584F](#) [MCH3443-TL-E](#) [MCH6422-TL-E](#) [FDPF9N50NZ](#) [FW216A-TL-2W](#) [FW231A-TL-E](#) [APT5010JVR](#) [NTNS3A92PZT5G](#)
[IRF100S201](#) [JANTX2N5237](#) [2SK2464-TL-E](#) [2SK3818-DL-E](#) [FCA20N60_F109](#) [FDZ595PZ](#) [STD6600NT4G](#) [FSS804-TL-E](#) [2SJ277-DL-E](#)
[2SK1691-DL-E](#) [2SK2545\(Q,T\)](#) [D2294UK](#) [405094E](#) [423220D](#) [MCH6646-TL-E](#) [TPCC8103,L1Q\(CM](#) [367-8430-0972-503](#) [VN1206L](#)
[424134F](#) [026935X](#) [051075F](#) [SBVS138LT1G](#) [614234A](#) [715780A](#) [NTNS3166NZT5G](#) [751625C](#) [873612G](#) [IRF7380TRHR](#)
[IPS70R2K0CEAKMA1](#) [RJK60S3DPP-E0#T2](#) [RJK60S5DPK-M0#T0](#) [APT5010JVFR](#) [APT12031JFLL](#) [APT12040JVR](#) [DMN3404LQ-7](#)
[NTE6400](#) [JANTX2N6796U](#) [JANTX2N6784U](#) [JANTXV2N5416U4](#) [SQM110N05-06L-GE3](#) [SIHF35N60E-GE3](#)