

## Description

### 500V N-CHANNEL ENHANCEMENT MODE POWER MOSFET

#### Features

$V_{DSS}$	$R_{DS(ON)}(Max)$ @ $V_{GS} = 10V$	$I_D$
500V	1.4 $\Omega$	5A

- Fast switching
- 100% avalanche tested
- Improved dv/dt capability
- RoHS Compliant & Halogen-Free

#### Application

- DC Motor Control and Class D Amplifier
- Uninterruptible Power Supply (UPS)
- HID

#### package

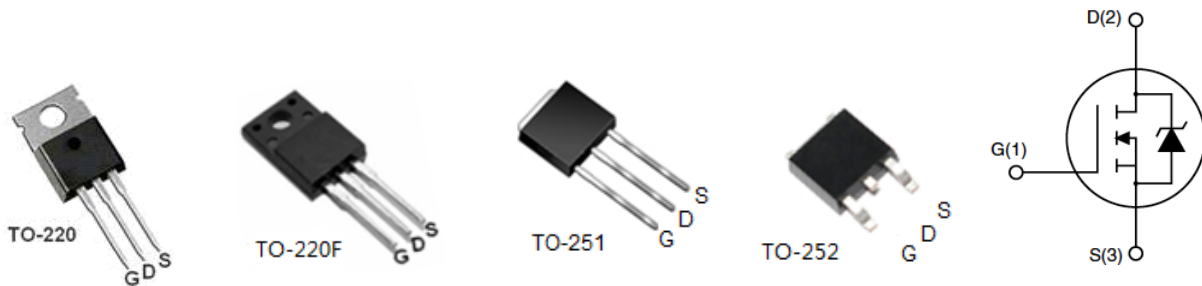

## Ordering Information

Part Number	Marking	Case	Packaging
G5N50T	G5N50	TO-220	50pcs/Tube
G5N50F	G5N50	TO-220F	50pcs/Tube
G5N50J	G5N50	TO-251	72pcs/Tube
G5N50K	G5N50	TO-252	2500pcs/Reel

## Absolute Maximum Ratings $T_C=25^\circ C$ unless otherwise specified

Symbol	Parameter	Max.			Units	
		TO-220	TO220F	TO251 TO252		
$V_{DSS}$	Drain-Source Voltage	500			V	
$V_{GSS}$	Gate-Source Voltage	$\pm 30$			V	
$I_D$	Continuous Drain Current	$T_C = 25^\circ C$	5	5*	5*	A
		$T_C = 100^\circ C$	3.2	3.2*	3.2*	A
$I_{DM}$	Pulsed Drain Current <sup>note1</sup>	20	20*	20*	A	
$E_{AS}$	Single Pulsed Avalanche Energy <sup>note2</sup>	150			mJ	
$P_D$	Power Dissipation	$T_C = 25^\circ C$	100	33	45	W
	Linear Derating Factor	$T_C > 25^\circ C$	0.8	0.27	0.36	W/ $^\circ C$
$R_{\theta JC}$	Thermal Resistance, Junction to Case	1.25	3.75	2.8	$^\circ C/W$	
$T_J, T_{STG}$	Operating and Storage Temperature Range	-55 to +150			$^\circ C$	

\*Drain current limited by maximum junction temperature

## Electrical Characteristics $T_C=25^\circ\text{C}$ unless otherwise specified

Symbol	Parameter	Test Condition	Min.	Typ.	Max.	Units
<b>Off Characteristic</b>						
$V_{(BR)DSS}$	Drain-Source Breakdown Voltage	$V_{GS} = 0V, I_D = 250\mu A$	500	-	-	V
$\Delta V_{(BR)DSS} / \Delta T_J$	Breakdown Voltage Temperature Coefficient	Reference to $25^\circ\text{C}$ , $I_D = 250\mu A$	-	0.5	-	$V/^\circ\text{C}$
$I_{DSS}$	Zero Gate Voltage Drain Current	$V_{DS} = 500V, V_{GS} = 0V$	-	-	1	$\mu A$
		$V_{DS} = 400V, T_C = 125^\circ\text{C}$	-	-	10	$\mu A$
$I_{GSS}$	Gate to Body Leakage Current	$V_{DS} = 0V, V_{GS} = \pm 30V$	-	-	$\pm 100$	nA
<b>On Characteristics</b>						
$V_{GS(th)}$	Gate Threshold Voltage <sup>note4</sup>	$V_{DS} = V_{GS}, I_D = 250\mu A$	2	-	4	V
$R_{DS(on)}$	Static Drain-Source On-Resistance	$V_{GS} = 10V, I_D = 2.5A$	-	-	1.4	$\Omega$
$g_{FS}$	Forward Transconductance	$V_{DS} = 30V, I_D = 2.5A$	-	3.0	-	S
<b>Dynamic Characteristics</b>						
$C_{iss}$	Input Capacitance	$V_{DS} = 25V, V_{GS} = 0V,$ $f = 1.0\text{MHz}$	-	586	-	pF
$C_{oss}$	Output Capacitance		-	58.8	-	pF
$C_{rss}$	Reverse Transfer Capacitance		-	3.2	-	pF
$Q_g$	Total Gate Charge	$V_{DD} = 400V, I_D = 5A,$ $V_{GS} = 10V$	-	13.4	-	nC
$Q_{gs}$	Gate-Source Charge		-	2.77	-	nC
$Q_{gd}$	Gate-Drain("Miller") Charge		-	4.43	-	nC
<b>Switching Characteristics</b>						
$t_{d(on)}$	Turn-On Delay Time	$V_{DD} = 250V, I_D = 5A,$ $R_G = 10\Omega, V_{GS} = 10V$	-	12.1	-	ns
$t_r$	Turn-On Rise Time		-	11.5	-	ns
$t_{d(off)}$	Turn-Off Delay Time		-	33.3	-	ns
$t_f$	Turn-Off Fall Time		-	7.33	-	ns
<b>Drain-Source Diode Characteristics and Maximum Ratings</b>						
$I_S$	Maximum Continuous Drain to Source Diode Forward Current		-	-	5	A
$I_{SM}$	Maximum Pulsed Drain to Source Diode Forward Current		-	-	20	A
$V_{SD}$	Drain to Source Diode Forward Voltage	$V_{GS} = 0V, I_S = 5A$	-	-	1.4	V
$t_{rr}$	Reverse Recovery Time	$V_{GS} = 0V, I_F = 5A,$ $di/dt = 100A/\mu s$	-	387	-	ns
$Q_{rr}$	Reverse Recovery Charge		-	1.5	-	$\mu C$

Notes:

1. Repetitive Rating: Pulse width limited by maximum junction temperature
2.  $L = 10\text{mH}, I_{AS} = 6A, V_{DD} = 50V, R_G = 25\Omega$ , Starting  $T_J = 25^\circ\text{C}$
3.  $I_{SD} \leq 5A, di/dt \leq 200A/\mu s, V_{DD} \leq B_{VDSS}$ , Starting  $T_J = 25^\circ\text{C}$
4. Pulse width  $\leq 300\mu s$ ; duty cycle  $\leq 2\%$ .

## Typical Performance Characteristics

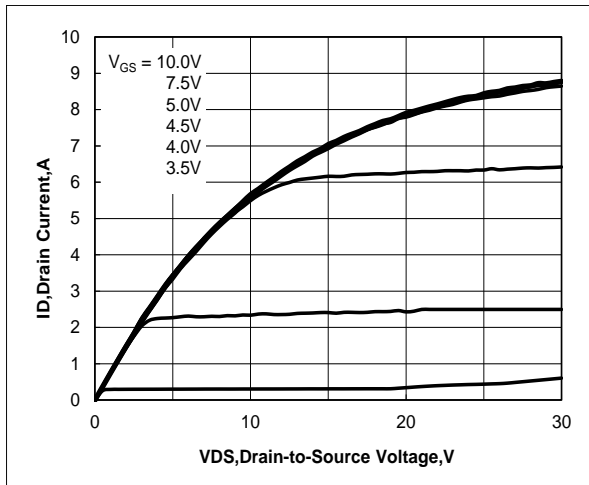

Figure 1. Output Characteristics

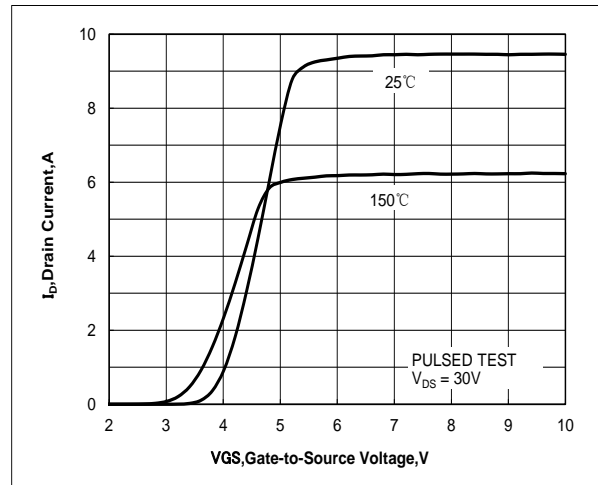

Figure 2. Transfer Characteristics

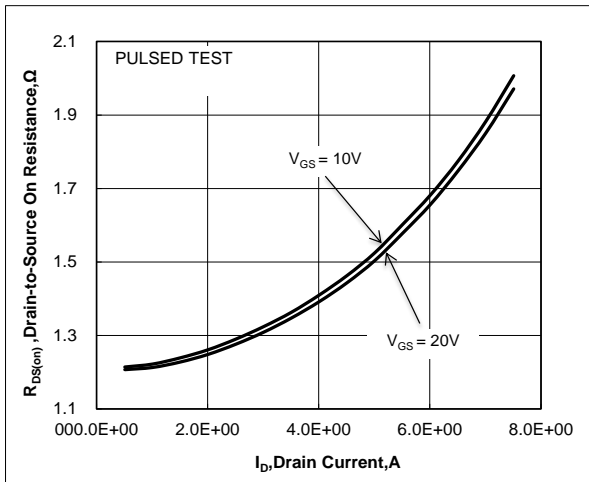

Figure 3. Drain-to-Source On Resistance vs. Drain Current and Gate Voltage

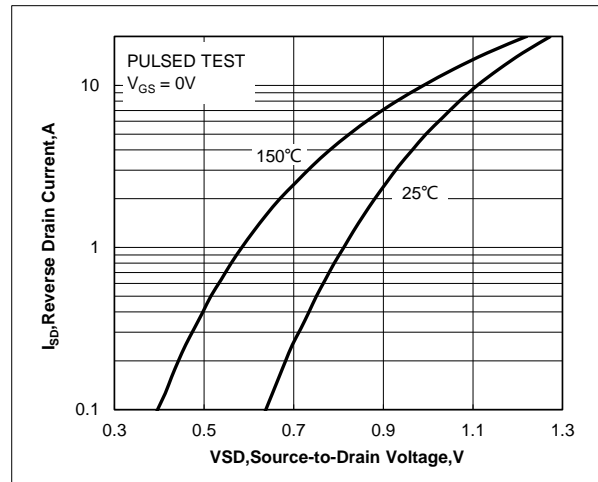

Figure 4. Body Diode Forward Voltage vs. Source Current and Temperature

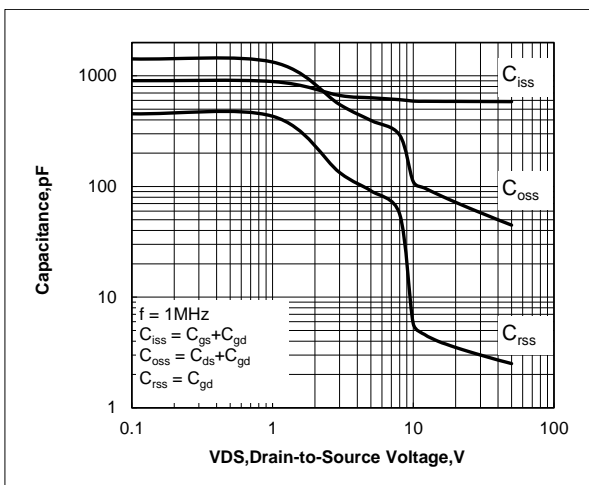

Figure 5. Capacitance Characteristics

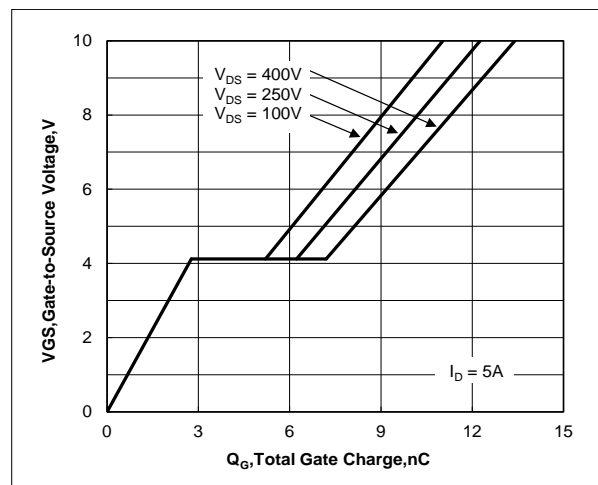

Figure 6. Gate Charge Characteristics

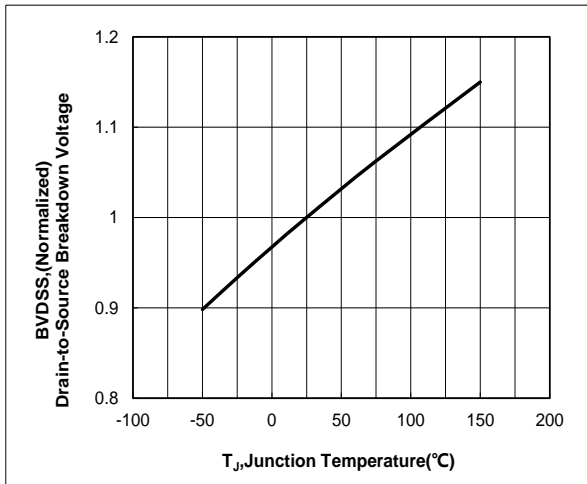

Figure 7. Normalized Breakdown Voltage vs. Junction Temperature

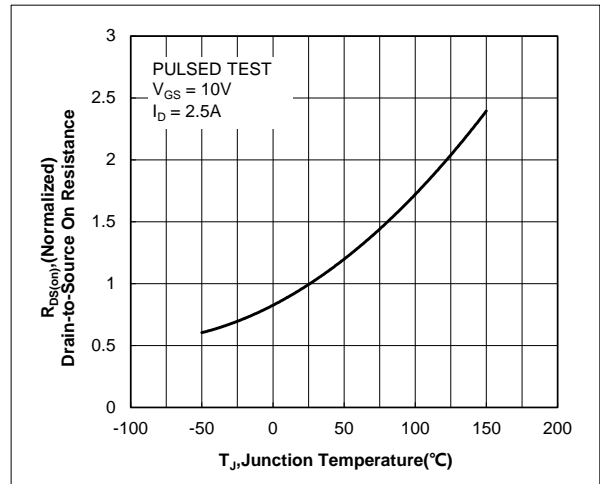

Figure 8. Normalized On Resistance vs. Junction Temperature

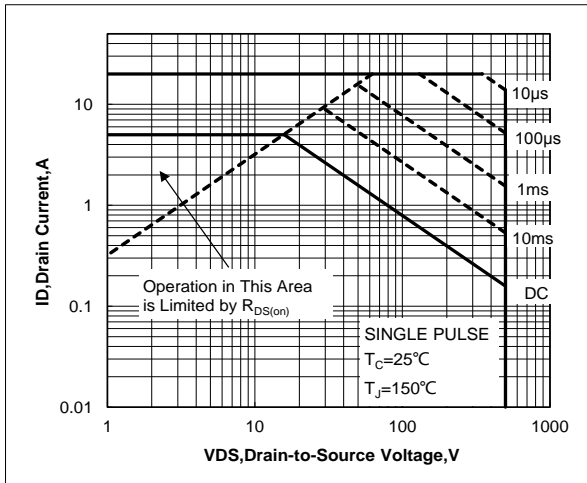

Figure 9. Maximum Safe Operating Area

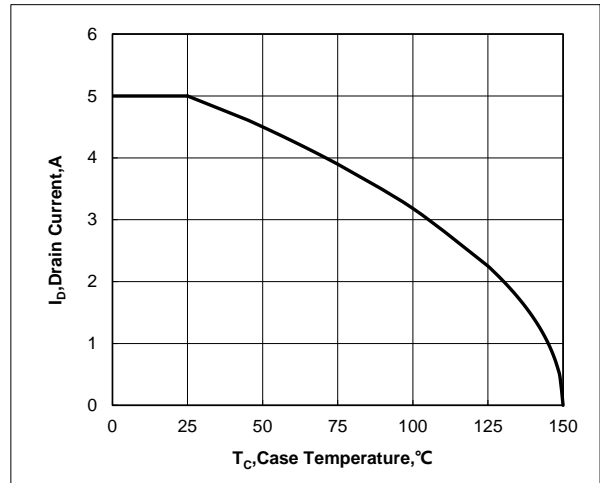

Figure 10. Maximum Continuous Drain Current vs. Case Temperature

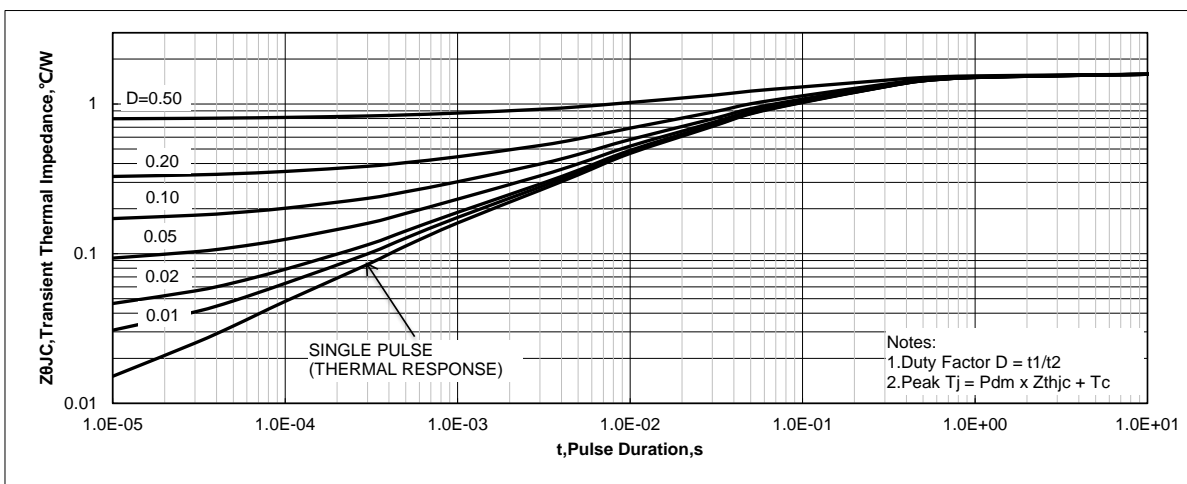

Figure 11. Maximum Effective Transient Thermal Impedance, Junction-to-Case

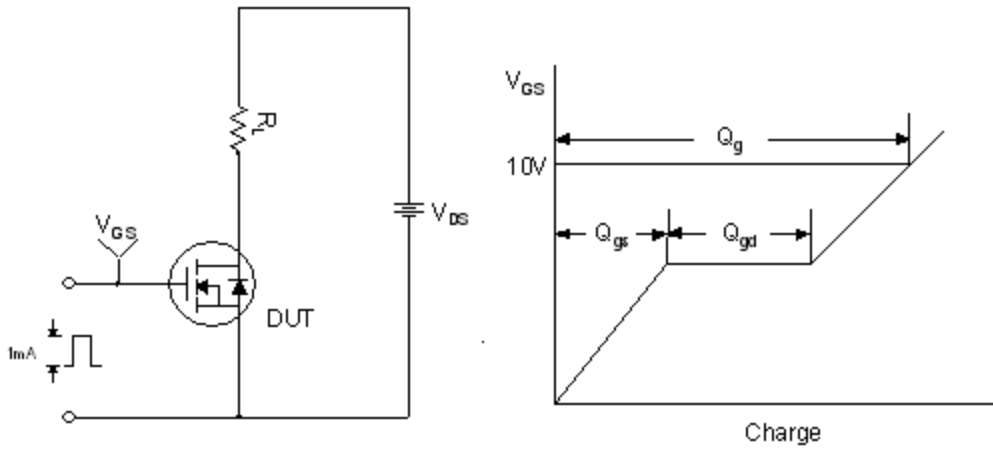

Figure 12. Gate Charge Test Circuit & Waveform

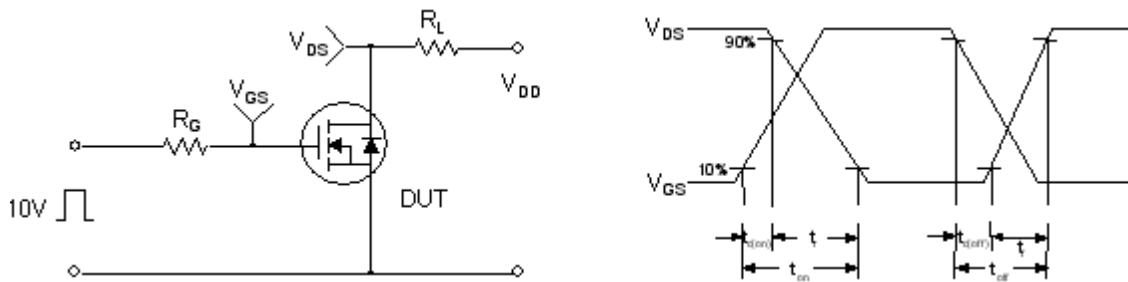

Figure 13. Resistive Switching Test Circuit & Waveforms

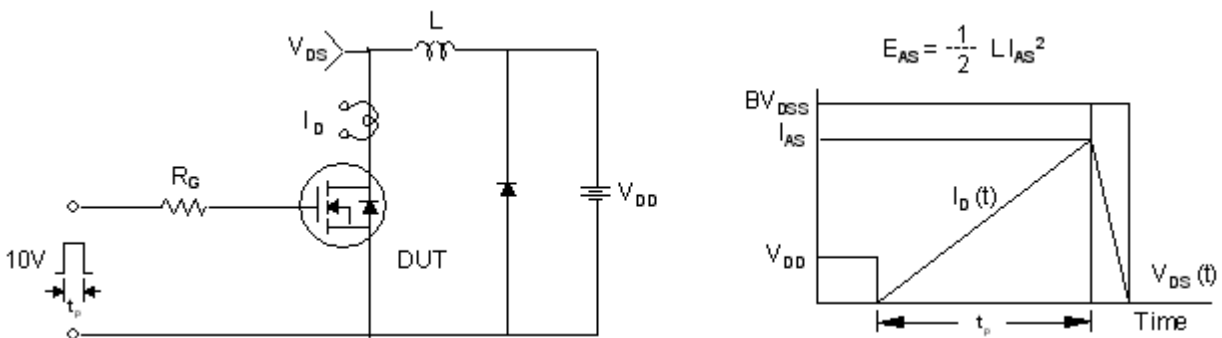

Figure 14. Unclamped Inductive Switching Test Circuit & Waveforms

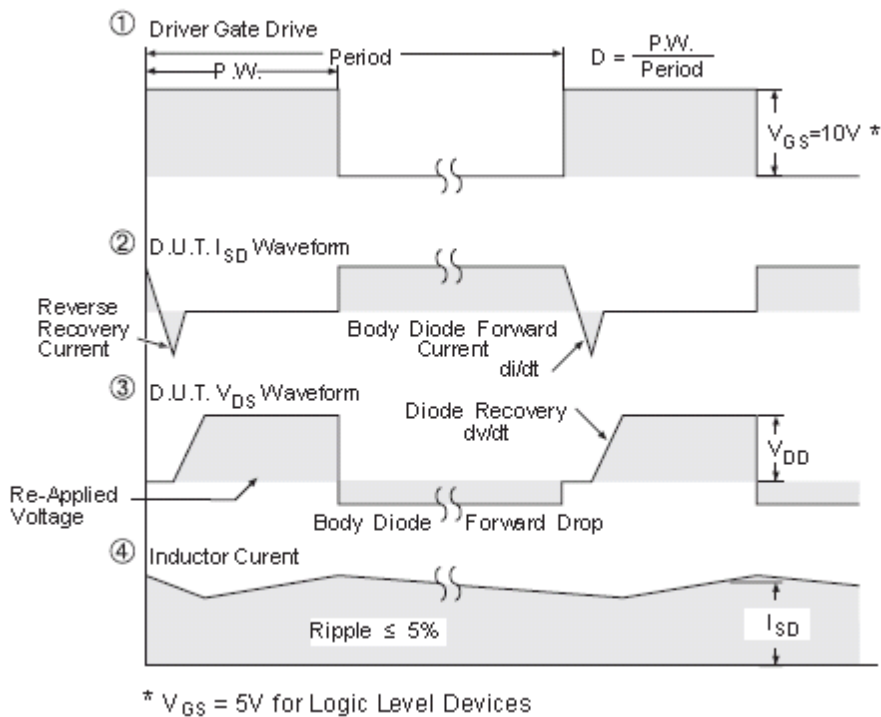
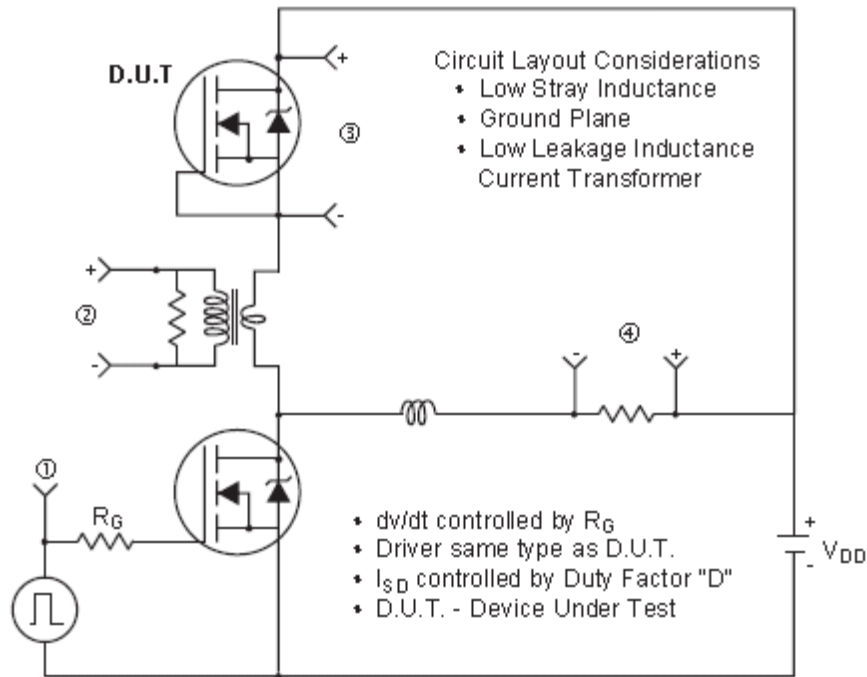
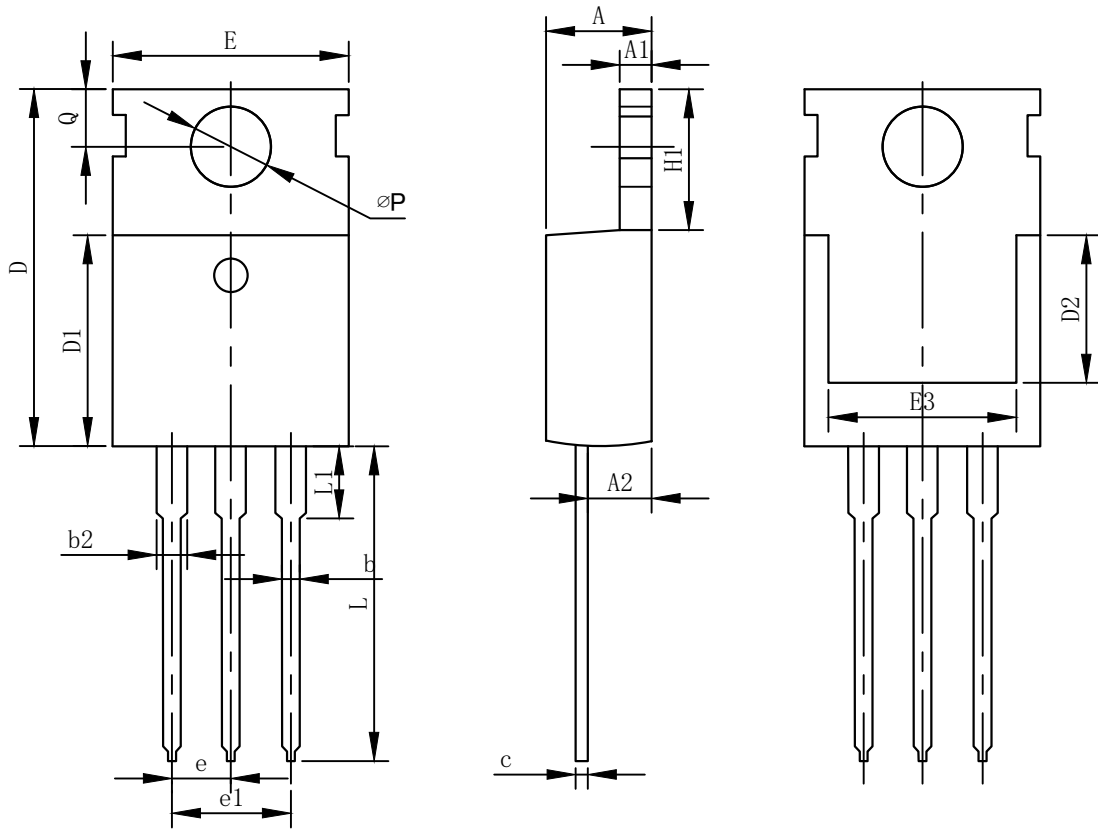

Figure 15. Peak Diode Recovery  $dv/dt$  Test Circuit & Waveforms (For N-channel)

## TO-220 Package information



COMMON DIMENSIONS

SYMBOL	mm		
	MIN	NOM	MAX
A	4.37	4.57	4.70
A1	1.25	1.30	1.40
A2	2.20	2.40	2.60
b	0.70	0.80	0.95
b2	1.70	1.27	1.47
c	0.45	0.50	0.60
D	15.10	15.60	16.10
D1	8.80	9.10	9.40
D2	5.50	-	-
E	9.70	10.00	10.30
E3	7.00	-	-
e	2.54BSC		
e1	5.08BSC		
H1	6.25	6.50	6.85
L	12.75	13.50	13.80
L1	-	3.10	3.40
$\phi P$	3.40	3.60	3.80
Q	2.60	2.80	3.00

## TO-220F Package information

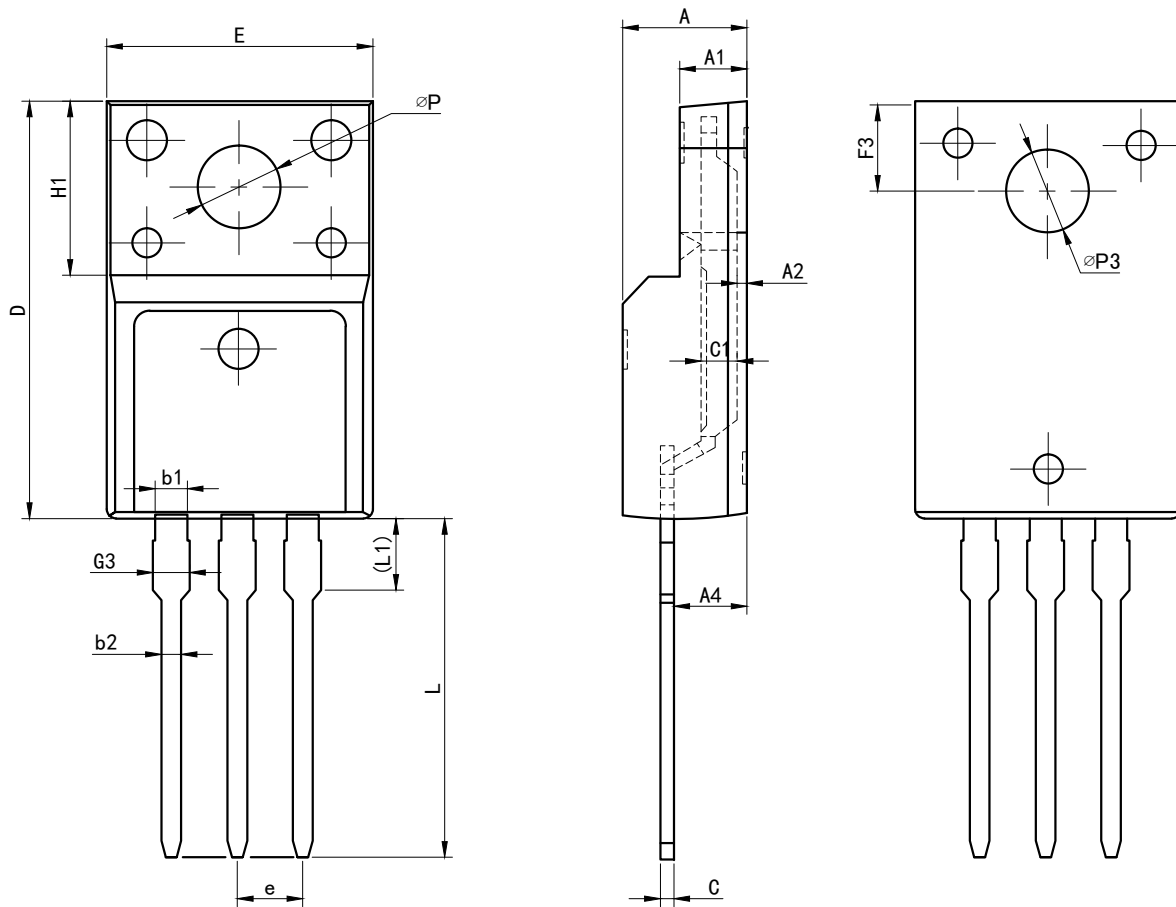

### COMMON DIMENSIONS

SYMBOL	mm		
	MIN	NOM	MAX
E	9.96	10.16	10.36
A	4.50	4.70	4.90
A1	2.34	2.54	2.74
A2	0.30	0.45	0.60
A4	2.56	2.76	2.96
c	0.40	0.50	0.65
c1	1.20	1.30	1.35
D	15.57	15.87	16.17
H1	6.70REF		
e	2.54BSC		
L	12.68	12.98	13.28
L1	2.93	3.03	3.13
$\phi P$	3.03	3.18	3.38
$\phi P3$	3.15	3.45	3.65
F3	3.15	3.30	3.45
G3	1.25	1.35	1.55
b1	1.18	1.28	1.43
b2	0.70	0.80	0.95



TO-251 Package information

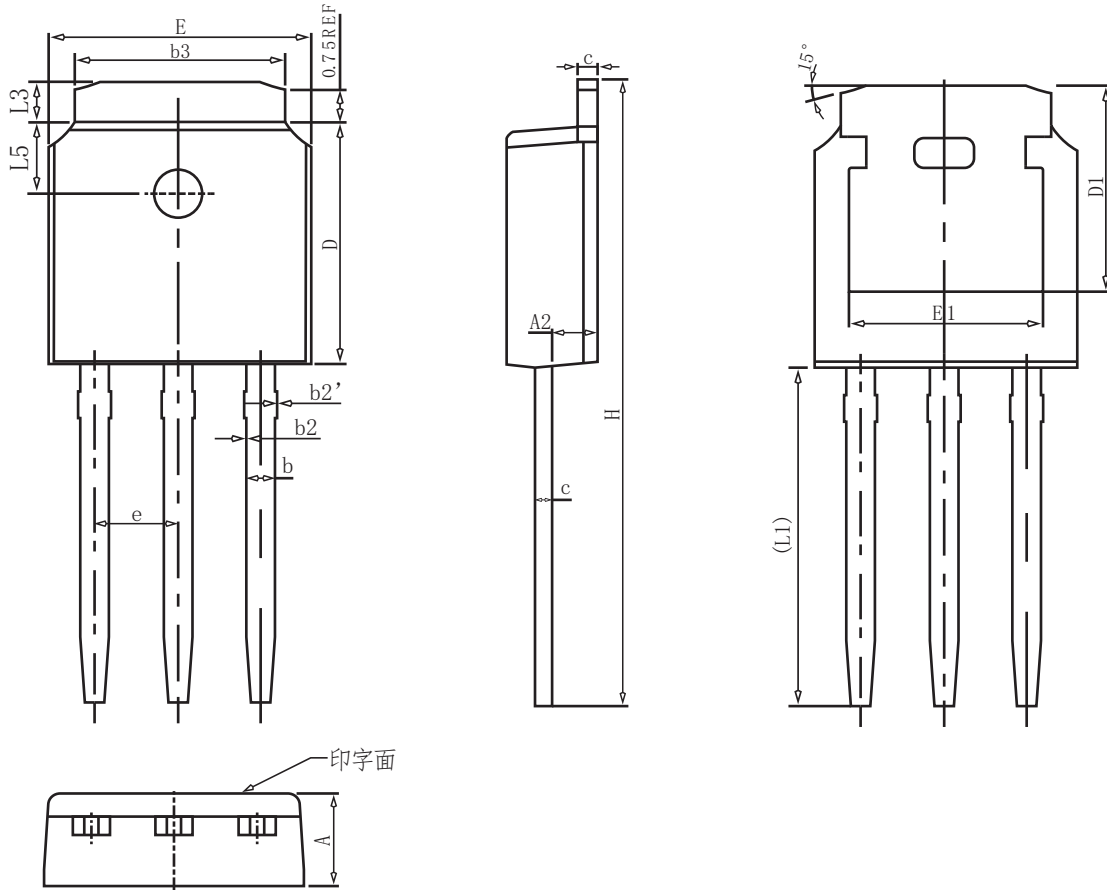

COMMON DIMENSIONS

SYMBOL	mm		
	MIN	NOM	MAX
A	2.20	2.30	2.40
A2	0.97	1.07	1.17
b	0.68	0.78	0.90
b2	0.00	0.04	0.10
b2'	0.00	0.04	0.10
b3	5.20	5.33	5.50
c	0.43	0.53	0.63
D	5.98	6.10	6.22
D1	5.30REF		
E	6.40	6.60	6.80
E1	4.63	-	-
e	2.286BSC		
H	16.22	16.52	16.82
L1	9.15	9.40	9.65
L3	0.88	1.02	1.28
L5	1.65	1.80	1.95

## TO-252 Package information

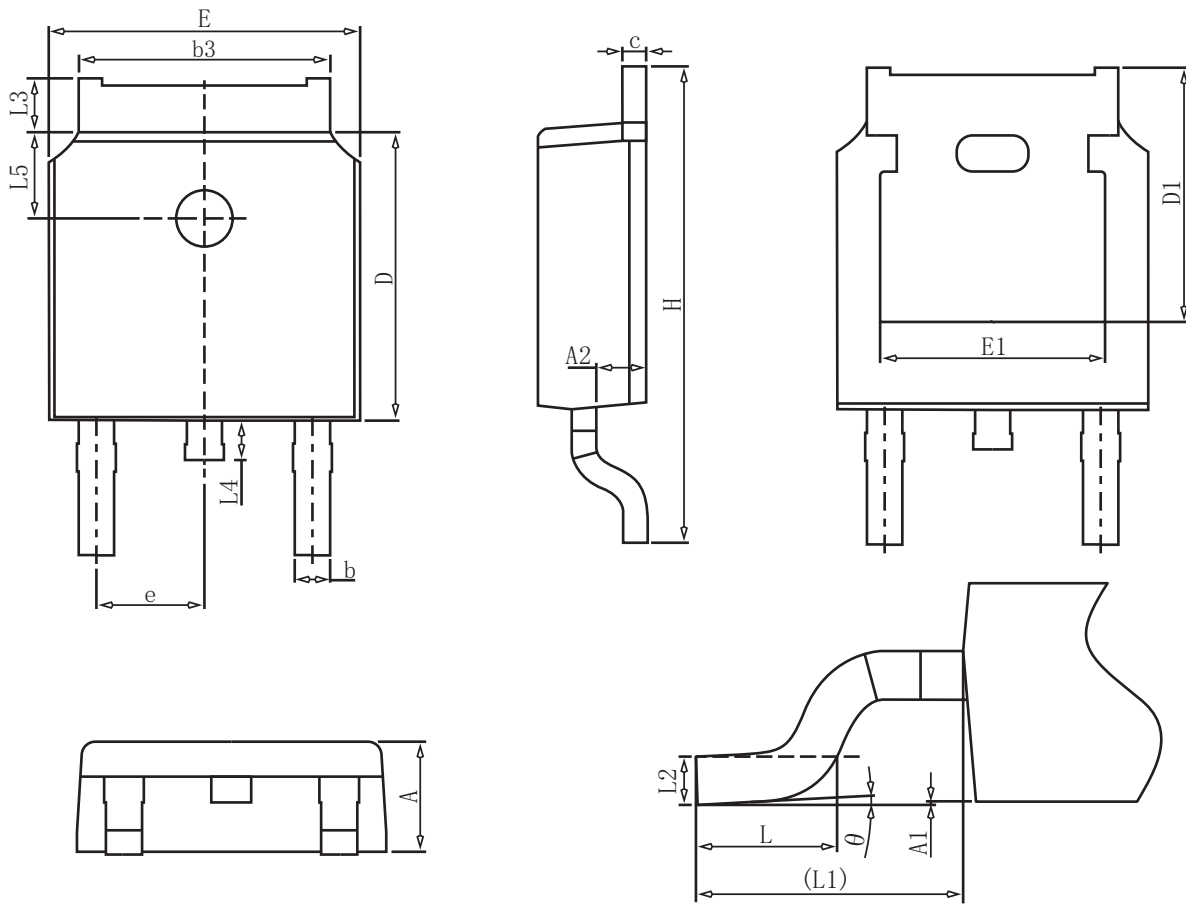

### COMMON DIMENSIONS

SYMBOL	mm		
	MIN	NOM	MAX
A	2.20	2.30	2.40
A1	0.00	-	0.20
A2	0.97	1.07	1.17
b	0.68	0.78	0.90
b3	5.20	5.33	5.50
c	0.43	0.53	0.63
D	5.98	6.10	6.22
D1	5.30REF		
E	6.40	6.60	6.80
E1	4.63	-	-
e	2.286BSC		
H	9.40	10.10	10.50
L	1.38	1.50	1.75
L1	2.90REF		
L2	0.51BSC		
L3	0.88	-	1.28
L4	0.50	-	1.00
L5	1.65	1.80	1.95
theta	0°	-	8°

## X-ON Electronics

Largest Supplier of Electrical and Electronic Components

*Click to view similar products for [MOSFET](#) category:*

*Click to view products by [GOFORD](#) manufacturer:*

Other Similar products are found below :

[614233C](#) [648584F](#) [MCH3443-TL-E](#) [MCH6422-TL-E](#) [FDPF9N50NZ](#) [FW216A-TL-2W](#) [FW231A-TL-E](#) [APT5010JVR](#) [NTNS3A92PZT5G](#)  
[IRF100S201](#) [JANTX2N5237](#) [2SK2464-TL-E](#) [2SK3818-DL-E](#) [FCA20N60\\_F109](#) [FDZ595PZ](#) [STD6600NT4G](#) [FSS804-TL-E](#) [2SJ277-DL-E](#)  
[2SK1691-DL-E](#) [2SK2545\(Q,T\)](#) [D2294UK](#) [405094E](#) [423220D](#) [MCH6646-TL-E](#) [TPCC8103,L1Q\(CM](#) [367-8430-0972-503](#) [VN1206L](#)  
[424134F](#) [026935X](#) [051075F](#) [SBVS138LT1G](#) [614234A](#) [715780A](#) [NTNS3166NZT5G](#) [751625C](#) [873612G](#) [IRF7380TRHR](#)  
[IPS70R2K0CEAKMA1](#) [RJK60S3DPP-E0#T2](#) [RJK60S5DPK-M0#T0](#) [APT5010JVFR](#) [APT12031JFLL](#) [APT12040JVR](#) [DMN3404LQ-7](#)  
[NTE6400](#) [JANTX2N6796U](#) [JANTX2N6784U](#) [JANTXV2N5416U4](#) [SQM110N05-06L-GE3](#) [SIHF35N60E-GE3](#)