

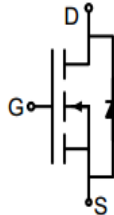
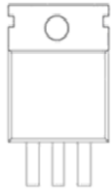

N-Channel Enhancement Mode Power MOSFET

| | | | |
|--|----------------|---|------------------|
| <p>Description</p> <p>The G60N06T uses advanced trench technology to provide excellent $R_{DS(ON)}$, low gate charge. It can be used in a wide variety of applications.</p> <p>General Features</p> <ul style="list-style-type: none"> ● V_{DS} 60V ● I_D (at $V_{GS} = 10V$) 50A ● $R_{DS(ON)}$ (at $V_{GS} = 10V$) < 17mΩ ● $R_{DS(ON)}$ (at $V_{GS} = 4.5V$) < 21mΩ ● 100% Avalanche Tested ● RoHS Compliant <p>Application</p> <ul style="list-style-type: none"> ● Power switch ● DC/DC converters | |  <p>Schematic diagram</p>  <p>Marking and pin assignment</p>  <p>TO-220</p> | |
| Device | Package | Marking | Packaging |
| G60N06T | TO-220 | G60N06 | 50pcs/Tube |

| Absolute Maximum Ratings $T_C = 25^\circ C$, unless otherwise noted | | | |
|---|----------------|------------|------|
| Parameter | Symbol | Value | Unit |
| Drain-Source Voltage | V_{DS} | 60 | V |
| Continuous Drain Current | I_D | 50 | A |
| Pulsed Drain Current (note1) | I_{DM} | 200 | A |
| Gate-Source Voltage | V_{GS} | ±20 | V |
| Power Dissipation | P_D | 85 | W |
| Single pulse avalanche energy (note3) | E_{AS} | 42 | mJ |
| Operating Junction and Storage Temperature Range | T_J, T_{stg} | -55 To 150 | °C |
| Thermal Resistance | | | |
| Parameter | Symbol | Value | Unit |
| Thermal Resistance, Junction-to-Case | R_{thJC} | 1.8 | °C/W |

| Specifications $T_J = 25^\circ\text{C}$, unless otherwise noted | | | | | | |
|--|---------------|---|-------|------|-----------|------------|
| Parameter | Symbol | Test Conditions | Value | | | Unit |
| | | | Min. | Typ. | Max. | |
| Static Parameters | | | | | | |
| Drain-Source Breakdown Voltage | $V_{(BR)DSS}$ | $V_{GS} = 0V, I_D = 250\mu A$ | 60 | -- | -- | V |
| Zero Gate Voltage Drain Current | I_{DSS} | $V_{DS} = 60V, V_{GS} = 0V$ | -- | -- | 1 | μA |
| Gate-Source Leakage | I_{GSS} | $V_{GS} = \pm 20V$ | -- | -- | ± 100 | nA |
| Gate-Source Threshold Voltage | $V_{GS(th)}$ | $V_{DS} = V_{GS}, I_D = 250\mu A$ | 1 | 1.5 | 2 | V |
| Drain-Source On-Resistance | $R_{DS(on)}$ | $V_{GS} = 10V, I_D = 5A$ | -- | 14 | 17 | m Ω |
| | | $V_{GS} = 4.5V, I_D = 3A$ | -- | 16 | 21 | |
| Forward Transconductance | g_{FS} | $V_{DS}=5V, I_D=20A$ | 18 | -- | -- | S |
| Dynamic Parameters | | | | | | |
| Input Capacitance | C_{iss} | $V_{GS} = 0V,$ $V_{DS} = 30V,$ $f = 1.0MHz$ | -- | 2050 | -- | pF |
| Output Capacitance | C_{oss} | | -- | 158 | -- | |
| Reverse Transfer Capacitance | C_{rss} | | -- | 120 | -- | |
| Total Gate Charge | Q_g | $V_{DD} = 30V,$ $I_D = 20A,$ $V_{GS} = 10V$ | -- | 50 | -- | nC |
| Gate-Source Charge | Q_{gs} | | -- | 6 | -- | |
| Gate-Drain Charge | Q_{gd} | | -- | 15 | -- | |
| Turn-on Delay Time | $t_{d(on)}$ | $V_{DD} = 30V,$ $I_D = 20A,$ $R_G = 3\Omega$ | -- | 7 | -- | ns |
| Turn-on Rise Time | t_r | | -- | 5 | -- | |
| Turn-off Delay Time | $t_{d(off)}$ | | -- | 28 | -- | |
| Turn-off Fall Time | t_f | | -- | 5.5 | -- | |
| Drain-Source Body Diode Characteristics | | | | | | |
| Continuous Body Diode Current | I_S | $T_C = 25^\circ\text{C}$ | -- | -- | 50 | A |
| Body Diode Voltage | V_{SD} | $T_J = 25^\circ\text{C}, I_{SD} = 15A, V_{GS} = 0V$ | -- | -- | 1.2 | V |
| Reverse Recovery Time | T_{rr} | $I_S = 10A, V_{GS} = 0V$ $di/dt=100A/us$ | -- | 28 | -- | ns |

Notes

1. Repetitive Rating: Pulse width limited by maximum junction temperature
2. Identical low side and high side switch with identical R_G
3. EAS condition : $T_J=25^\circ\text{C}, V_{DD}=50V, V_{GS}=10V, L=0.5mH, R_g=25\Omega$

Gate Charge Test Circuit

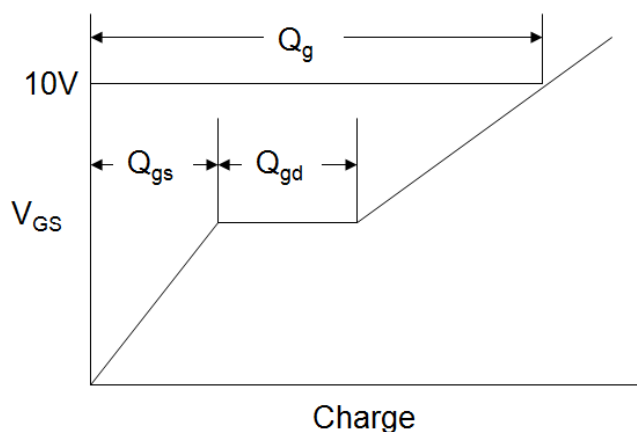
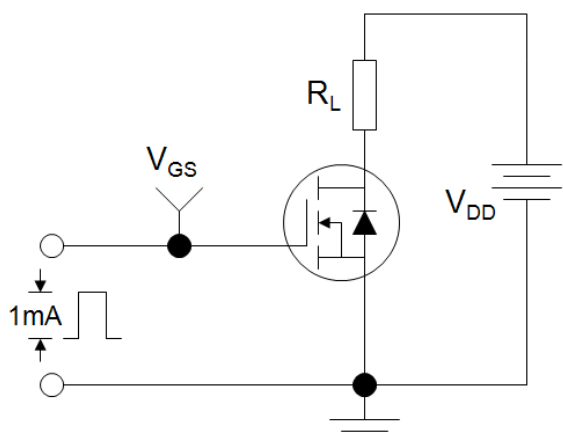

Switch Time Test Circuit

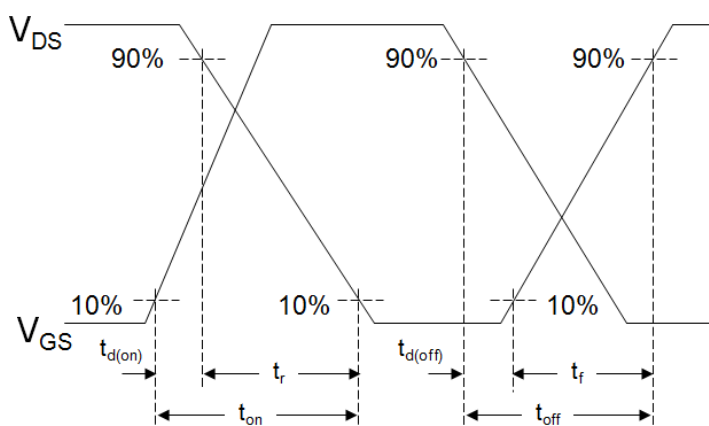
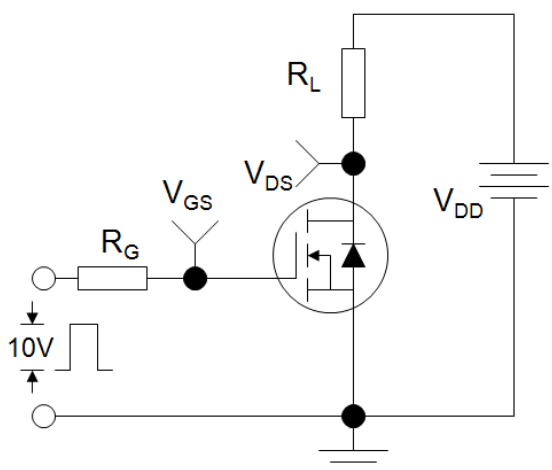

EAS Test Circuit

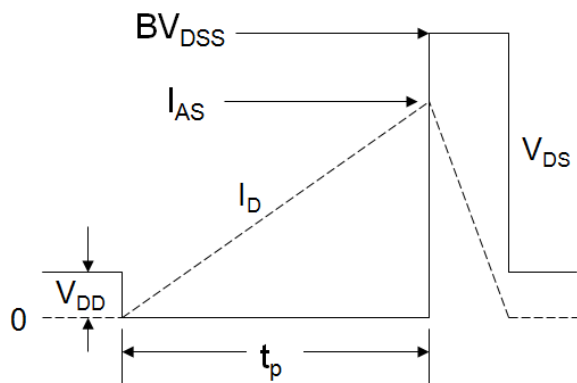
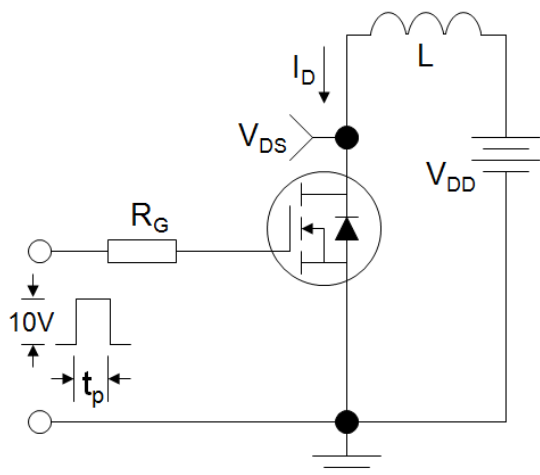

Typical Characteristics $T_J = 25^\circ\text{C}$, unless otherwise noted

Figure 1. Output Characteristics

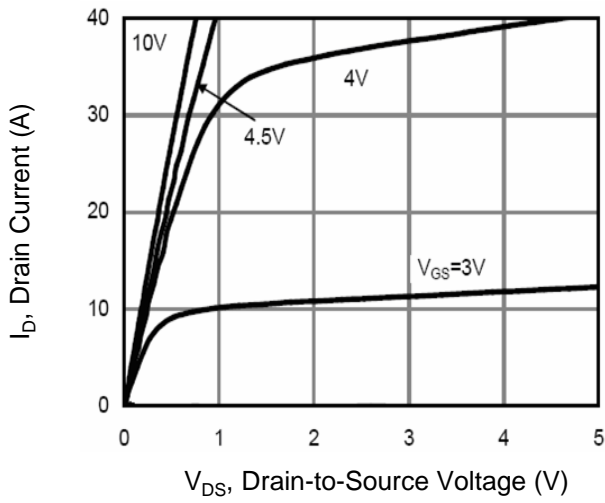

Figure 2. Transfer Characteristics

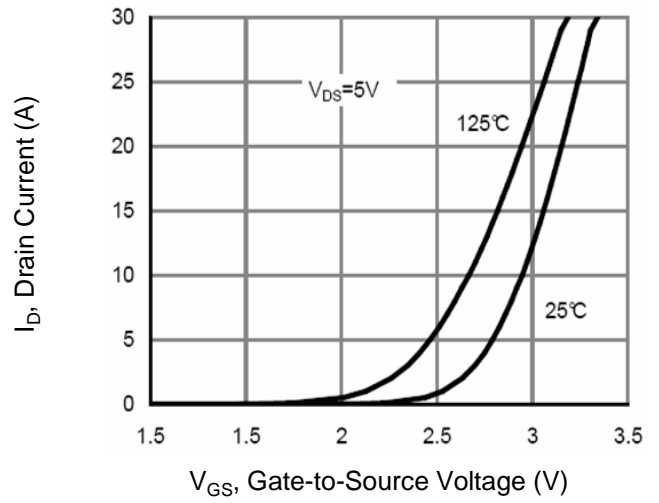

Figure 3. Gate Charge

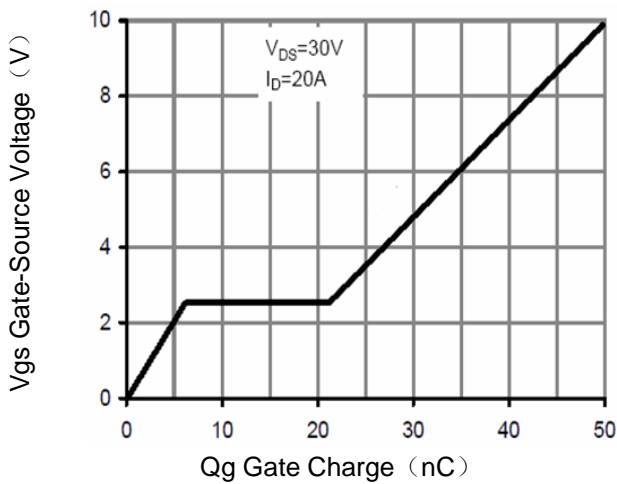

Figure 4. Drain Source On Resistance

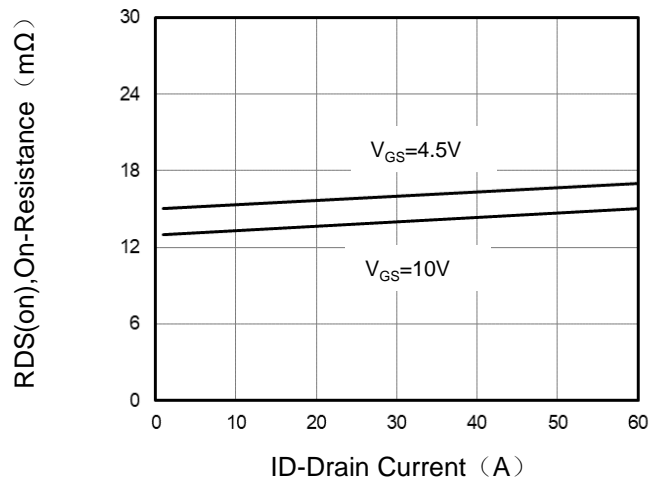

Figure 5. Capacitance

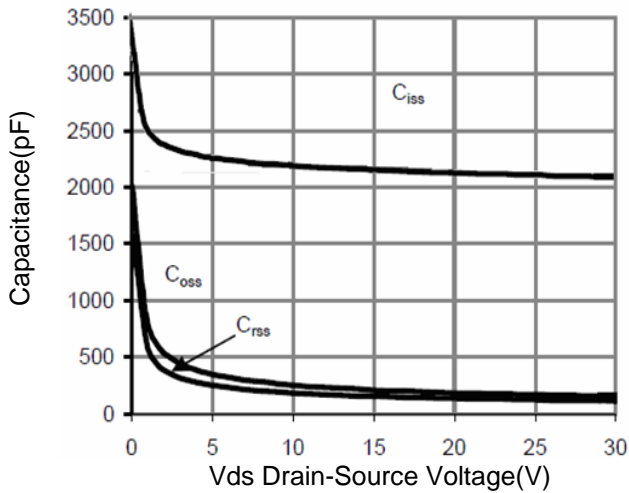
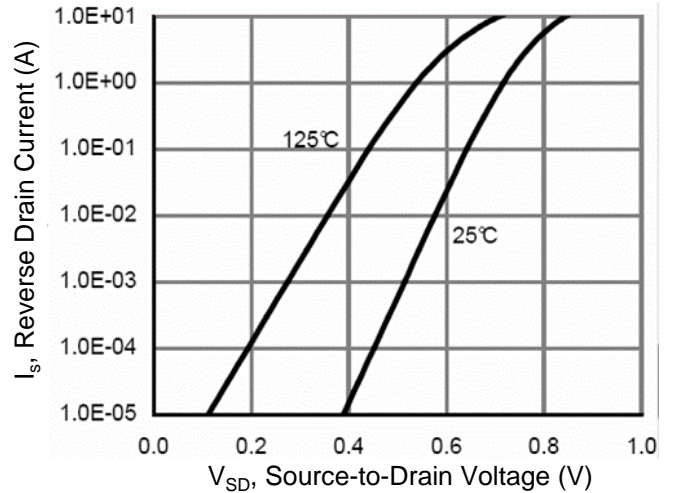

Figure 6. Source-Drain Diode Forward



Typical Characteristics $T_J = 25^\circ\text{C}$, unless otherwise noted

Figure 7. Drain-Source On-Resistance

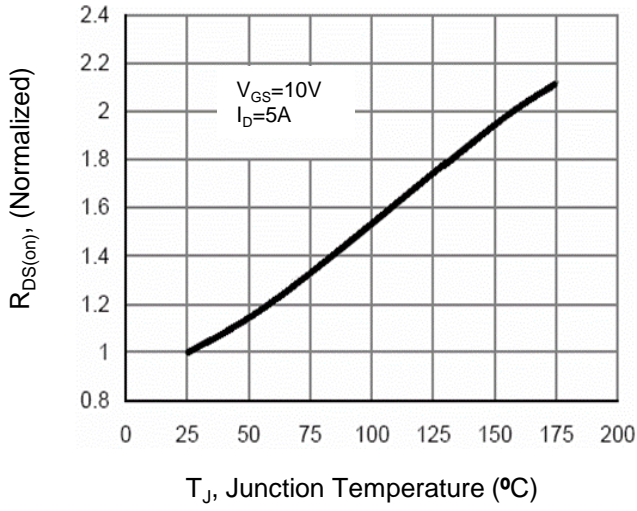

Figure 8. Safe Operation Area

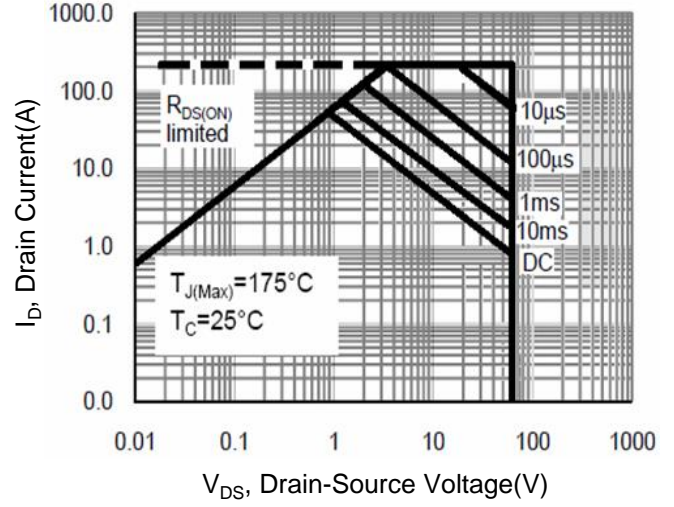
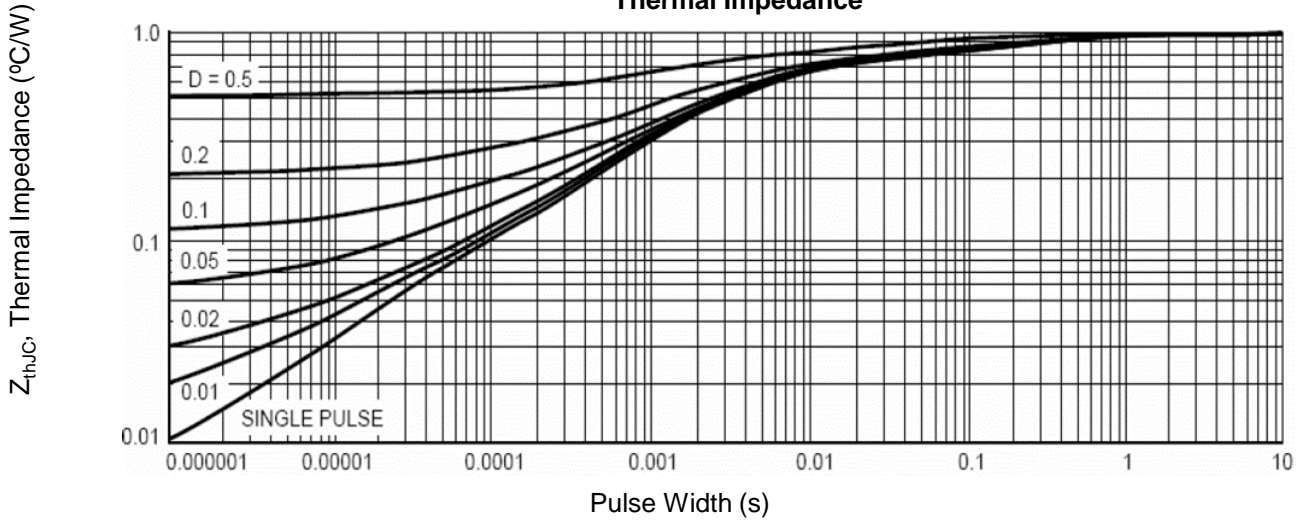
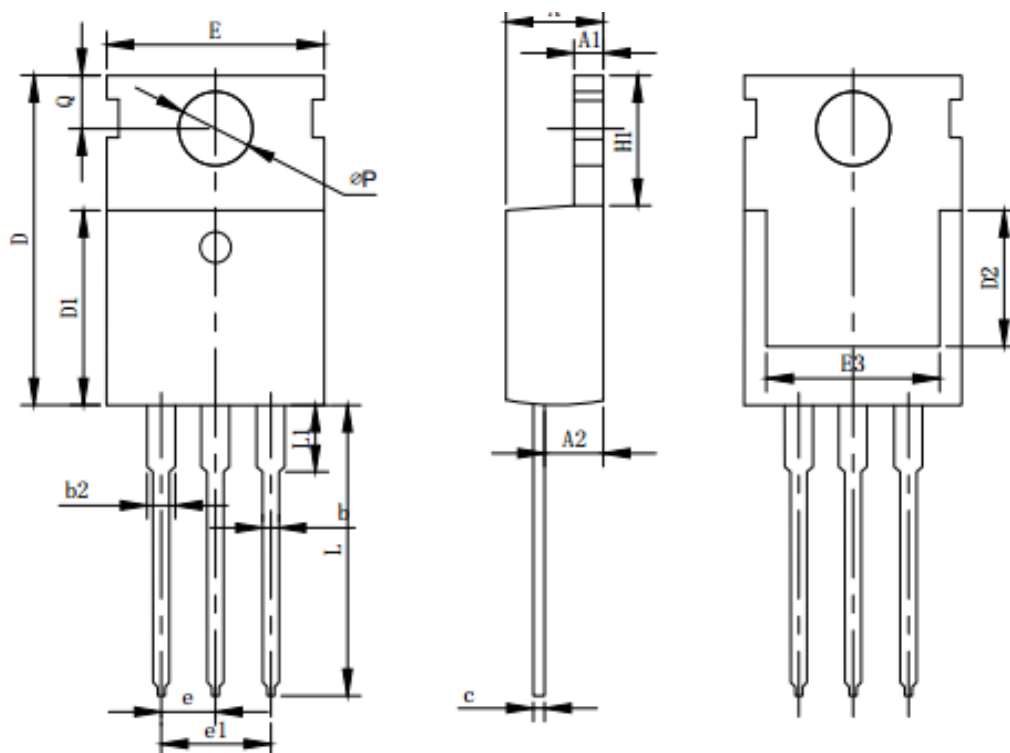

Figure 9. Normalized Maximum Transient Thermal Impedance



TO-220 Package Information



| Symbol | Dimensions in Millimeters | | |
|--------|---------------------------|------|------|
| | MIN. | NOM. | MAX. |
| A | 4.37 | 4.57 | 4.7 |
| A1 | 1.25 | 1.3 | 1.4 |
| A2 | 2.2 | 2.4 | 2.6 |
| b | 0.7 | 0.8 | 0.95 |
| b2 | 1.7 | 1.27 | 1.47 |
| c | 0.45 | 0.5 | 0.6 |
| D | 15.1 | 15.6 | 16.1 |
| D1 | 8.8 | 9.1 | 9.4 |
| D2 | 5.5 | | |
| E | 9.7 | 10 | 10.3 |
| e | 2.54BSC | | |
| e1 | 5.08BSC | | |
| H1 | 6.25 | 6.5 | 6.85 |
| L | 12.75 | 13.5 | 13.8 |
| L1 | | 3.1 | 3.4 |
| øP | 3.4 | 3.6 | 3.8 |
| Q | 2.6 | 2.8 | 3 |

X-ON Electronics

Largest Supplier of Electrical and Electronic Components

Click to view similar products for [MOSFET](#) category:

Click to view products by [GOFORD](#) manufacturer:

Other Similar products are found below :

[IRFD120](#) [JANTX2N5237](#) [BUK455-60A/B](#) [MIC4420CM-TR](#) [VN1206L](#) [NDP4060](#) [SI4482DY](#) [IPS70R2K0CEAKMA1](#) [SQD23N06-31L-GE3](#)
[TK16J60W,S1VQ\(O](#) [2SK2614\(TE16L1,Q\)](#) [DMN1017UCP3-7](#) [DMN1053UCP4-7](#) [SQJ469EP-T1-GE3](#) [NTE2384](#) [DMC2700UDMQ-7](#)
[DMN2080UCB4-7](#) [DMN61D9UWQ-13](#) [US6M2GTR](#) [DMN31D5UDJ-7](#) [DMP22D4UFO-7B](#) [DMN1006UCA6-7](#) [DMN16M9UCA6-7](#)
[STF5N65M6](#) [IRF40H233XTMA1](#) [STU5N65M6](#) [DMN6022SSD-13](#) [DMN13M9UCA6-7](#) [DMTH10H4M6SPS-13](#) [DMN2990UFB-7B](#)
[IPB80P04P405ATMA2](#) [2N7002W-G](#) [MCAC30N06Y-TP](#) [MCQ7328-TP](#) [NTMC083NP10M5L](#) [BXP7N65D](#) [BXP4N65F](#) [AOL1454G](#)
[WMJ80N60C4](#) [BXP2N20L](#) [BXP2N65D](#) [BXT1150N10J](#) [BXT1700P06M](#) [TSM60NB380CP](#) [ROG](#) [RQ7L055BGTGR](#) [DMNH15H110SK3-13](#)
[SLF10N65ABV2](#) [BSO203SP](#) [BSO211P](#) [IPA60R230P6](#)