

### FEATURES

- \* Ideal for printed circuit board
- \* Reliable low cost construction utilizing molded plastic technique
- \* High surge current capability
- \* Polarity: marked on body
- \* Mounting position: Any
- \* Weight: 0.38 grams

### VOLTAGE RANGE

50 to 1000 Volts

### CURRENT

2.0 Ampere

DB - 1

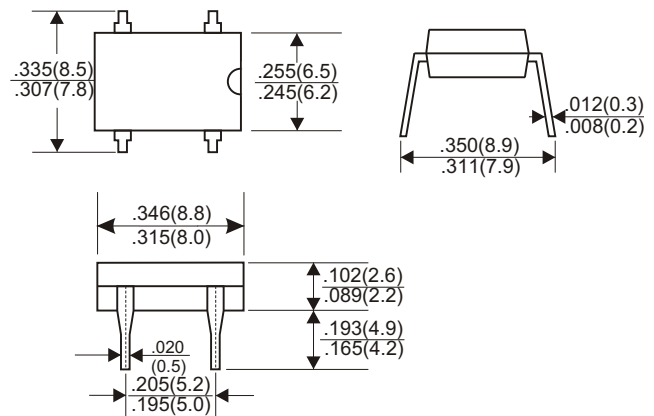

Dimensions in inches and (millimeters)

## MAXIMUM RATINGS AND ELECTRICAL CHARACTERISTICS

Rating 25°C ambient temperature unless otherwise specified.  
Single phase half wave, 60Hz, resistive or inductive load.  
For capacitive load, derate current by 20%.

TYPE NUMBER	DB201	DB202	DB203	DB204	DB205	DB206	DB207	UNITS	
Maximum Recurrent Peak Reverse Voltage	50	100	200	400	600	800	1000	V	
Maximum RMS Voltage	35	70	140	280	420	560	700	V	
Maximum DC Blocking Voltage	50	100	200	400	600	800	1000	V	
Maximum Average Forward Rectified Current									
.375" (9.5mm) Lead Length at Ta=40°C								2.0	A
Peak Forward Surge Current, 8.3 ms single half sine-wave superimposed on rated load (JEDEC method)								60	A
Maximum Forward Voltage Drop per Bridge Element at 2.0A D.C.								1.1	V
Maximum DC Reverse Current Ta=25°C								5	µA
at Rated DC Blocking Voltage Ta=125°C								500	µA
Operating Temperature Range, Tj								-65 — +150	°C
Storage Temperature Range, Tstg								-65 — +150	°C

## RATING AND CHARACTERISTIC CURVES (DB201 THRU DB207)

FIG.1-TYPICAL FORWARD CURRENT DERATING CURVE

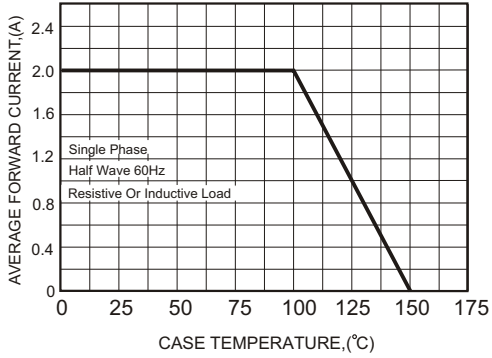

FIG.2-MAXIMUM NON-REPETITIVE FORWARD SURGE CURRENT

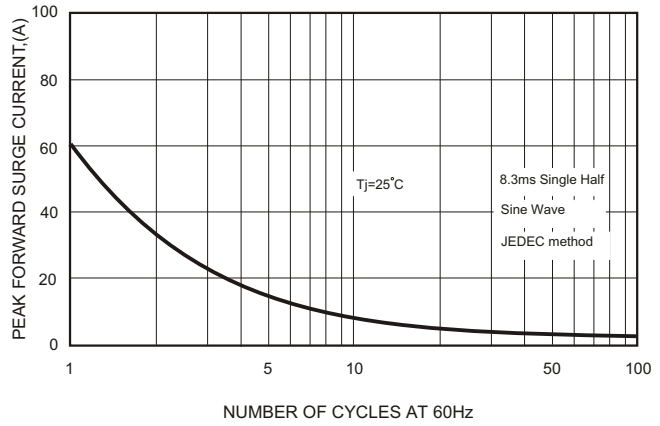

FIG.3-TYPICAL FORWARD CHARACTERISTICS

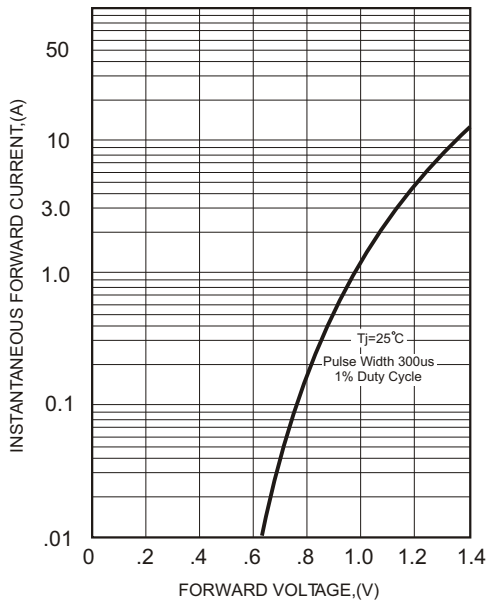
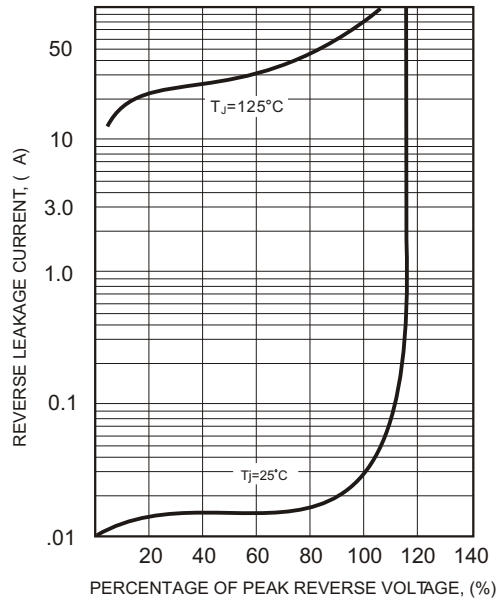

FIG.4-TYPICAL REVERSE CHARACTERISTICS



## X-ON Electronics

Largest Supplier of Electrical and Electronic Components

*Click to view similar products for [Bridge Rectifiers](#) category:*

*Click to view products by [GOODWORK](#) manufacturer:*

Other Similar products are found below :

[MB2510](#) [MB252](#) [MB356G](#) [MB358G](#) [MP358-BP](#) [90MT160KPBF](#) [GBJ1504-BP](#) [GBU10B-BP](#) [GBU15J-BP](#) [GBU15K-BP](#) [GBU4A-BP](#)  
[GBU4D-BP](#) [GSIB680-E3/45](#) [DB101-BP](#) [DF01](#) [DF10SA-E345](#) [BU1508-E3/45](#) [BU1510-E3/45](#) [KBPC50-10S](#) [RS405GL-BP](#) [26MT120](#)  
[G5SBA60-E3/51](#) [GBJ1502-BP](#) [GBU10J-BP](#) [GBU4J-BP](#) [GBU6M](#) [GBU8D-BP](#) [GBU8J-BP](#) [GSIB1520-E3/45](#) [TB102M](#) [MB1510](#) [MB6M-G](#)  
[MB86](#) [TL401G](#) [MDA920A2](#) [TU602](#) [TU810](#) [MP501W-BP](#) [MP502-BP](#) [BR1005-BP](#) [BR101-BP](#) [BR84DTP204](#) [BU1010A-E3/51](#) [BU1508-](#)  
[E3/51](#) [BU2006-E3/45](#) [BU2008-E3/51](#) [US15KB80R-7000](#) [KBPC25-02](#) [VS-60MT120KPBF](#) [DB105-BP](#)