



GW1NR series of FPGA Products

Data Sheet

DS117-2.9.5E, 03/18/2022

Copyright © 2022 Guangdong Gowin Semiconductor Corporation. All Rights Reserved.

GOWIN, LittleBee, and GOWIN are trademarks of Guangdong Gowin Semiconductor Corporation and are registered in China, the U.S. Patent and Trademark Office, and other countries. All other words and logos identified as trademarks or service marks are the property of their respective holders. No part of this document may be reproduced or transmitted in any form or by any means, electronic, mechanical, photocopying, recording or otherwise, without the prior written consent of GOWINSEMI.

Disclaimer

GOWINSEMI assumes no liability and provides no warranty (either expressed or implied) and is not responsible for any damage incurred to your hardware, software, data, or property resulting from usage of the materials or intellectual property except as outlined in the GOWINSEMI Terms and Conditions of Sale. GOWINSEMI may make changes to this document at any time without prior notice. Anyone relying on this documentation should contact GOWINSEMI for the current documentation and errata.

Revision History

Date	Version	Description
06/06/2018	1.6E	Initial version published.
06/25/2018	1.7E	<ul style="list-style-type: none"> ● The PLL structure view updated. The input clock is CLKIN; ● MG81 package content added; ● PSRAM description and electrical characteristics added.
08/01/2018	1.8E	The systemIO status for blank chips added.
09/25/2018	1.9E	PSRAM description modified and PSRAM data width added.
12/13/2018	2.0E	<ul style="list-style-type: none"> ● The recommended working conditions updated; ● The package and the memory table added; ● The device of GW1NR-4B added; ● The step delay of IODELAY changed from 25ps to 30ps ● The part name updated.
01/09/2019	2.1E	<ul style="list-style-type: none"> ● Oscillator frequency updated; ● QN88 of GW1NR-4 embedded with PSRAM added; ● Reference manuals of SDRAM and PSRAM updated.
07/09/2019	2.2E	<ul style="list-style-type: none"> ● The supply voltage of UV devices updated; ● Both LV devices and UV devices have same static supply current; ● “Environment temperature” in Table 4-1 changed to “Junction temperature”; ● The GW1NR-9 MG100 package added.
08/23/2019	2.3E	PSRAM capacity and data width updated.
11/18/2019	2.4E	<ul style="list-style-type: none"> ● Number of Max. I/O updated; ● LQ144 package size updated; ● GW1NR-9 static current parameters added; ● IODELAY description added.
03/04/2020	2.5E	Description of User Flash updated.
04/16/2020	2.6E	<ul style="list-style-type: none"> ● GW1NR-9 added. ● CFU view updated.
05/18/2020	2.6.1E	The GW1NR-9 MG100PF package added.
06/12/2020	2.6.2E	<ul style="list-style-type: none"> ● GW1NR-9C revised to GW1NR-9; ● Figures of part naming updated; ● One note for MG100PF added in 2.3 Package Information.
07/10/2020	2.7E	<ul style="list-style-type: none"> ● GW1NR-1 added; ● MIPI transmission rate for the GW1NR-9 device added; ● A note to “Package Mark Example” added.
07/28/2020	2.8E	The GW1NR-9 MG100PD package added.
09/28/2020	2.8.1E	<ul style="list-style-type: none"> ● GW1NR-9 MG100PA, MG100PT, and MG100PS added; ● GW1NR-9 MG100PD removed.
02/04/2021	2.9E	The new device of GW1NR-2 added.
06/02/2021	2.9.1E	The description of configuration modes supported by GW1NR-2 MG49P added.
08/20/2021	2.9.2E	HCLK distribution views added and user Flash description updated.
10/26/2021	2.9.3E	GW1NR-1 EQ144G, EQ100G, QN32G, and QN48G added.
01/20/2022	2.9.4E	<ul style="list-style-type: none"> ● GW1NR-2 C5/I4 devices added; ● Static current and Programming current improved; ● I/O Logic Input and output view updated and port

Date	Version	Description
		description added; <ul style="list-style-type: none">● GW1NR-1 QN48X, LQ100G, and QN32X added;● GW1NR-1 QN48G and QN32G removed.
03/18/2022	2.9.5E	<ul style="list-style-type: none">● The static current of GW1NR-1 device updated

Contents

Contents	i
List of Figures	iii
List of Tables	v
1 About This Guide	1
1.1 Purpose	1
1.2 Related Documents	1
1.3 Abbreviations and Terminology	2
1.4 Support and Feedback	3
2 General Description	4
2.1 Features	4
2.2 Product Resources	7
2.3 Package Information	7
3 Architecture	10
3.1 Architecture Overview	10
3.2 Memory	12
3.3 Configurable Function Unit	16
3.4 IOB	19
3.5 Block SRAM (BSRAM)	31
3.6 User Flash (GW1NR-1)	38
3.7 User Flash (GW1NR-2/4/9)	38
3.8 DSP	39
3.9 MIPI D-PHY (GW1NR-2)	42
3.10 Clock	43
3.11 Long Wire (LW)	48
3.12 Global Set/Reset (GSR)	48
3.13 Programming Configuration	49
3.14 On Chip Oscillator	49
4 AC/DC Characteristics	52
4.1 Operating Conditions	52
4.2 ESD	54

4.3 DC Electrical Characteristics	54
4.4 Switching Characteristics	59
4.5 User Flash Characteristics	63
4.6 Configuration Interface Timing Specification	66
5 Ordering Information	67
5.1 Part Name.....	67
5.2 Package Mark Example.....	69

List of Figures

Figure 3-1 GW1NR-1/4/9 Architecture Overview	10
Figure 3-2 GW1NR-2 Architecture Overview	11
Figure 3-3 CFU View.....	16
Figure 3-4 Register in CLS	17
Figure 3-5 IOB Structure View	19
Figure 3-6 GW1NR-1/4/9 I/O Bank Distribution.....	20
Figure 3-7 GW1NR-2 I/O Bank Distribution	20
Figure 3-8 True LVDS Design	24
Figure 3-9 I/O Logic Output	25
Figure 3-10 I/O Logic Input	25
Figure 3-11 IODELAY.....	26
Figure 3-12 Register Structure in I/O Logic	26
Figure 3-13 IEM Structure.....	27
Figure 3-14 I/O Logic in Basic Mode.....	27
Figure 3-15 I/O Logic in SDR Mode.....	28
Figure 3-16 I/O Logic in DDR Input Mode	28
Figure 3-17 I/O Logic in DDR Output Mode.....	29
Figure 3-18 I/O Logic in IDES10 Mode	29
Figure 3-19 I/O Logic in OSER4 Mode	29
Figure 3-20 I/O Logic in IVideo Mode	29
Figure 3-21 I/O Logic in OVideo Mode	30
Figure 3-22 I/O Logic in IDES8 Mode	30
Figure 3-23 I/O Logic in OSER8 Mode	30
Figure 3-24 I/O Logic in IDES10 Mode	30
Figure 3-25 I/O Logic in OSER10 Mode	31
Figure 3-26 I/O Logic in IDES16 Mode	31
Figure 3-27 I/O Logic in OSER16 Mode	31
Figure 3-28 Pipeline Mode in Single Port, Dual Port and Semi Dual Port.....	35
Figure 3-29 Independent Clock Mode	37
Figure 3-30 Read/Write Clock Mode.....	37
Figure 3-31 Single Port Clock Mode	38
Figure 3-32 DSP Macro	40

Figure 3-33 PLL Structure (GW1NR-1/4/9).....	44
Figure 3-34 PLL Structure (GW1NR-2).....	45
Figure 3-35 GW1NR-1 HCLK Distribution	47
Figure 3-36 GW1NR-2 HCLK Distribution	47
Figure 3-37 GW1NR-4 HCLK Distribution	48
Figure 3-38 GW1NR-9 HCLK Distribution	48
Figure 4-1 GW1NR User Flash Read Operation	65
Figure 4-2 GW1NR User Flash Program Operation	65
Figure 4-3 GW1NR User Flash Erase Operation	65
Figure 5-1 Part Naming–ES.....	67
Figure 5-2 Part Naming–Production	68
Figure 5-3 Package Mark Example.....	69

List of Tables

Table 1-1 Abbreviations and Terminologies	2
Table 2-1 Product Resources.....	7
Table 2-2 Package and Memory Information	7
Table 2-3 Package Information, Max. I/O, and LVDS Pairs	8
Table 3-1 Register Description in CLS	17
Table 3-2 Output I/O Standards and Configuration Options	21
Table 3-3 Input I/O Standards and Configuration Options	22
Table 3-4 Memory Size Configuration	32
Table 3-5 Dual Port Mixed Read/Write Data Width Configuration	34
Table 3-6 Semi Dual Port Mixed Read/Write Data Width Configuration	34
Table 3-7 Clock Operations in Different BSRAM Modes	36
Table 3-8 DSP Ports Description	40
Table 3-9 Internal Registers Description	41
Table 3-10 PLL Ports Definition.....	44
Table 3-11 PLL Ports Definition.....	45
Table 3-12 GW1NR-1 Oscillator Output Frequency Options	50
Table 3-13 GW1NR-4 Oscillator Output Frequency Options	50
Table 3-14 GW1NR-2/9 Oscillator Output Frequency Options	50
Table 4-1 Absolute Max. Ratings	52
Table 4-2 Recommended Operating Conditions.....	53
Table 4-3 Power Supply Ramp Rates	53
Table 4-4 Hot Socket Specifications	53
Table 4-5 POR Characteristics.....	53
Table 4-6 GW1NR ESD – HBM	54
Table 4-7 GW1NR ESD - CDM.....	54
Table 4-8 DC Electrical Characteristics over Recommended Operating Conditions	54
Table 4-9 Static Current	55
Table 4-10 Programming Current.....	56
Table 4-11 I/O Operating Conditions Recommended	56
Table 4-12 IOB Single-Ended DC Electrical Characteristic	57
Table 4-13 IOB Differential Electrical Characteristics	58

Table 4-14 CFU Block Internal Timing Parameters.....	59
Table 4-15 BSRAM Internal Timing Parameters.....	59
Table 4-16 DSP Internal Timing Parameters	59
Table 4-17 Gearbox Internal Timing Parameters.....	60
Table 4-18 Single-ended IO Fmax	60
Table 4-19 External Switching Characteristics.....	61
Table 4-20 On chip Oscillator Output Frequency.....	61
Table 4-21 PLL Switching Characteristics.....	61
Table 4-22 User Flash DC Characteristics.....	63
Table 4-23 User Flash Timing Parameters	63

1 About This Guide

1.1 Purpose

This data sheet describes the features, product resources and structure, AC/DC characteristics, timing specifications of the configuration interface, and the ordering information of the GW1NR series of FPGA product. It is designed to help you understand the GW1NR series of FPGA products quickly and select and use devices appropriately.

1.2 Related Documents

The latest user guides are available on GOWINSEMI Website. You can find the related documents at www.gowinsemi.com:

1. [DS117, GW1NR series of FPGA Products Data Sheet](#)
2. [UG290, Gowin FPGA Products Programming and Configuration User Guide](#)
3. [UG119, GW1NR series of FPGA Products Package and Pinout](#)
4. [UG116, GW1NR-4 Pinout](#)
5. [UG803, GW1NR-9 Pinout](#)
6. [UG804, GW1NR-1 Pinout](#)
7. [UG805, GW1NR-2 Pinout](#)

1.3 Abbreviations and Terminology

The abbreviations and terminologies used in this manual are set out in Table 1-1 below.

Table 1-1 Abbreviations and Terminologies

Abbreviations and Terminology	Name
FPGA	Field Programmable Gate Array
SIP	System in Package
SDRAM	Synchronous Dynamic Random Access Memory
PSRAM	Pseudo Static Random Access Memory
CFU	Configurable Function Unit
CLS	Configurable Logic Section
CRU	Configurable Routing Unit
LUT4	4-input Look-up Tables
LUT5	5-input Look-up Tables
LUT6	6-input Look-up Tables
LUT7	7-input Look-up Tables
LUT8	8-input Look-up Tables
REG	Register
ALU	Arithmetic Logic Unit
IOB	Input/Output Block
SSRAM	Shadow Static Random Access Memory
BSRAM	Block Static Random Access Memory
SP	Single Port 16K BSRAM
SDP	Semi Dual Port 16K BSRAM
DP	True Dual Port 16K BSRAM
DSP	Digital Signal Processing
DQCE	Dynamic Quadrant Clock Enable
DCS	Dynamic Clock Selector
PLL	Phase-locked Loop
GPIO	Gowin Programmable IO
TDM	Time Division Multiplexing
MIPI	Mobile Industry Processor Interface
FN	QFN
QN	QFN
MG	MBGA
LQ	LQFP
EQ	ELQFP

1.4 Support and Feedback

Gowin Semiconductor provides customers with comprehensive technical support. If you have any questions, comments, or suggestions, please feel free to contact us directly using the information provided below.

Website: www.gowinsemi.com

E-mail: support@gowinsemi.com

2 General Description

The GW1NR series of FPGA products are the first generation products in the LittleBee® family and represent one form of SIP chip. The main difference between the GW1N series and the GW1NR series is that the GW1NR series integrates abundant Memory chip. The GW1NR series also provides low power consumption, instant on, low cost, non-volatile, high security, various packages, and flexible usage.

GOWINSEMI provides a new generation of FPGA hardware development environment through market-oriented independent research and development that supports the GW1NR series of FPGA products and applies to FPGA synthesizing, layout, place and routing, data bitstream generation and download, etc.

2.1 Features

- User Flash (GW1NR-1)
 - 100,000 write cycles
 - Greater than 10 years data retention at +85°C
 - Selectable 8/16/32 bits data-in and data-out
 - Page size: 256 bytes
 - 3 μA standby current
 - Page write time: 8.2 ms
- User Flash (GW1NR-2/4/9)
 - 10,000 write cycles
 - Greater than 10 years Data Retention at +85°C
 - Data Width: 32
 - GW1NR-2 capacity: 48 rows x 64 columns x 32 = 96K bits
 - GW1NR-4 capacity: 128 rows x 64 columns x 32 = 256K bits
 - GW1NR-9 capacity: 304 rows x 64 columns x 32 = 608 K bits
 - Page Erase Capability: 2,048 bytes per page
 - Word Programming Time: ≤16 μs
 - Page Erasure Time: ≤120 ms
- Lower power consumption
 - 55 nm embedded flash technology
 - LV: supports 1.2 V core voltage

- UV: Built-in linear voltage regulator unit, unified power supply of V_{CC} / V_{CCX} / V_{CCO}
- Clock dynamically turns on and off
- Integrate SDRAM/ PSRAM/ NOR FLASH
- Hard Core - MIPI D-PHY RX (GW1NR-2)
 - Interfaces to MIPI DSI and MIPI CSI-2, RX devices
 - IO Bank6 supports MIPI D-PHY RX
 - MIPI transmission rate up to 2Gbps;
 - Supports up to 4 data lanes and one clock lane
- Multi-function Highspeed FPGA IO - MIPI D-PHY RX/TX (GW1NR-2)
 - Interfaces to MIPI CSI2 and DSI, RX and TX devices
 - MIPI transmission rate up to 1.5Gbps per lane, 6Gbps per port;
 - IO Bank0, IO Bank3, IO Bank4, and IO Bank5 support MIPI D-PHY TX
 - IO Bank2 supports MIPI D-PHY RX
- Multiple I/O standards
 - LVCMOS33/25/18/15/12; LVTTTL33, SSTL33/25/18 I, SSTL33/25/18 II, SSTL15; HSTL18 I, HSTL18 II, HSTL15 I; PCI, LVDS25, RSDS, LVDS25E, BLVDSE
 - MLVDSE, LVPECLE, RSDSE
 - Input hysteresis option
 - Supports 4 mA, 8 mA, 16 mA, 24 mA, etc. drive options
 - Slew rate option
 - Output drive strength option
 - Individual bus keeper, weak pull-up, weak pull-down, and open drain option
 - Hot socket
 - BANK0 of GW1NR-9 supports MIPI I/O Input, and the MIPI transmission rate can be up to 1.2 Gbps
 - BANK2 of GW1NR-9 supports MIPI I/O Output, and the MIPI transmission rate can be up to 1.2 Gbps
 - BANK0 and BANK2 of GW1NR-9 support I3C OpenDrain/PushPull conversion
- High performance DSP
 - High performance digital signal processing ability
 - Supports 9 x 9, 18 x 18, 36 x 36 bits multiplier and 54 bits accumulator;
 - Multipliers cascading
 - Registers pipeline and bypass
 - Adaptive filtering through signal feedback
 - Supports barrel shifter
- Abundant slices
 - Four-input LUT (LUT4)
 - Double-edge flip-flops
 - Supports shift register and distributed register
- Block SRAM with multiple modes
 - Supports dual port, single port, and semi-dual port
 - Supports bytes write enable
- Flexible PLLs
 - Frequency adjustment (multiply and division) and phase

- adjustment
- Supports global clock
- Built-in flash programming
 - Instant-on
 - Supports security bit operation
 - Supports AUTO BOOT and DUAL BOOT
- Configuration
 - JTAG configuration
 - GW1NR-4 Version B supports JTAG transparent transmission
 - Offers up to seven GowinCONFIG configuration modes:
AUTOBOOT, SSPI, MSPI, CPU, SERIAL, DUAL BOOT, I²C Slave

2.2 Product Resources

Table 2-1 Product Resources

Device	GW1NR-1	GW1NR-2	GW1NR-4	GW1NR-9
LUT4	1,152	2304	4,608	8,640
Flip-Flop (FF)	864	2304(FF+Latch, where FF: 2016)	3,456	6,480
Shadow SRAM SSRAM (bits)	0	0	0	17,280
Block SRAM BSRAM (bits)	72K	72K	180K	468K
BSRAM quantity BSRAM	4	4	10	26
User Flash (bits)	96K	96K	256K	608K
SDR SDRAM (bits)	-	-	64M	64M
PSRAM(bits)	-	64M(MG49P) 32M(MG49PG)	32M(QN88P) 64M(MG81P)	64M(QN88P/LQ144P/ MG100PT/MG100PS) 128M(MG100P/MG10 0PF/ MG100PA)
NOR FIASH (bits)	4M	4M(MG49G/ MG49PG)	-	-
18 x 18 Multiplier	0	0	16	20
PLLs	1	1	2	2
Total number of I/O banks	4	7	4	4
Max. I/O	120	126	218	276
Core Voltage (LV)	1.2V	1.2V	1.2V	1.2V
Core Voltage (UV)	-	1.8V/2.5V/3.3V	2.5V/3.3V	

2.3 Package Information

Table 2-2 Package and Memory Information

Package	Device	Memory	Capacity	Bit Width
QN88	GW1NR-4	SDR SDRAM	64M	16 bits
	GW1NR-9	SDR SDRAM	64M	16 bits
QN88P	GW1NR-4	PSRAM	32M	8 bits
	GW1NR-9	PSRAM	64M	16 bits
MG81P	GW1NR-4	PSRAM	64M	16 bits
MG100P	GW1NR-9	PSRAM	128M	32 bits
MG100PF	GW1NR-9	PSRAM	128M	32 bits
MG100PA	GW1NR-9	PSRAM	128M	32 bits
MG100PT	GW1NR-9	PSRAM	64M	16 bits
MG100PS	GW1NR-9	PSRAM	64M	16 bits
LQ144P	GW1NR-9	PSRAM	64M	16 bits
FN32G	GW1NR-1	NOR FLASH	4M	1 bit

Package	Device	Memory	Capacity	Bit Width
EQ144G QN32X QN48X LQ100G				
MG49P	GW1NR-2	PSRAM	64M	16 bits
MG49G	GW1NR-2	NOR FLASH	4M	1 bit
MG49PG	GW1NR-2	PSRAM	32M (PSRAM)	8 bits
		NOR FLASH	4M (NOR FLASH)	1 bit

Table 2-3 Package Information, Max. User I/O, and LVDS Pairs

Package	Pitch(mm)	尺寸(mm)	GW1NR-1	GW1NR-2 ^[2]	GW1NR-4	GW1NR-9
QN88	0.4	10 x 10	-		70(11)	70(19)
QN88P	0.4	10 x 10	-		70(11)	70(17)
MG49P	0.5	3.8 x 3.8	-	30(8)	-	-
MG49PG	0.5	3.8 x 3.8	-	30(8)	-	-
MG49G	0.5	3.8 x 3.8	-	30(8)	-	-
MG81P	0.5	4.5 x 4.5	-		68(10)	-
MG100P	0.5	5 x 5	-		-	87(16)
MG100PF ^[1]	0.5	5 x 5	-		-	87(16)
MG100PA	0.5	5 x 5	-		-	87(17)
MG100PT	0.5	5 x 5	-		-	87(17)
MG100PS	0.5	5 x 5	-		-	87(17)
LQ144P	0.5	20 x 20	-		-	120(20)
EQ144G	0.5	20 x 20	112	-	-	-
FN32G	0.4	4 x 4	26	-	-	-
QN32X	0.5	5 x 5	22	-	-	-
QN48X	0.5	7 x 7	39	-	-	-
LQ100G	0.5	14 x 14	79	-	-	-

Note!

- [1] MG100PF: The pinout of ball C1/C2/D2/F1/F9/A7/A6 adjusted on the basis of MG100P.
- [2] GW1NR-2 MG49P/ MG49PG / MG49G only supports the configuration mode of I²C and Autoboot. When I²C is supported, the SDA and SCL pins need to be external pulled up.
- The package types in this data sheet are written with abbreviations. See 5.1 Part Name.
- For more detailed information, please refer to [UG804, GW1NR-1 Pinout](#), [UG805, GW1NR-2 Pinout](#), [UG116, GW1NR-4 Pinout](#), [UG801, GW1NR-9 Pinout](#), and [UG803, GW1NR-9 Pinout](#).

- JTAGSEL_N and JTAG pins cannot be used as I/O simultaneously. The Max. I/O noted in this table is referred to when the four JTAG pins (TCK, TDI, TDO, and TMS) are used as I/O. When mode [2:0] = 001, JTAGSEL_N and the four JTAG pins (TCK, TDI, TDO, and TMS) can be used as GPIO simultaneously, and the Max. user I/O is increased by one. See [UG119, GW1NR series of FPGA Products Package and Pinout Manual](#) for more details.

3 Architecture

3.1 Architecture Overview

Figure 3-1 GW1NR-1/4/9 Architecture Overview

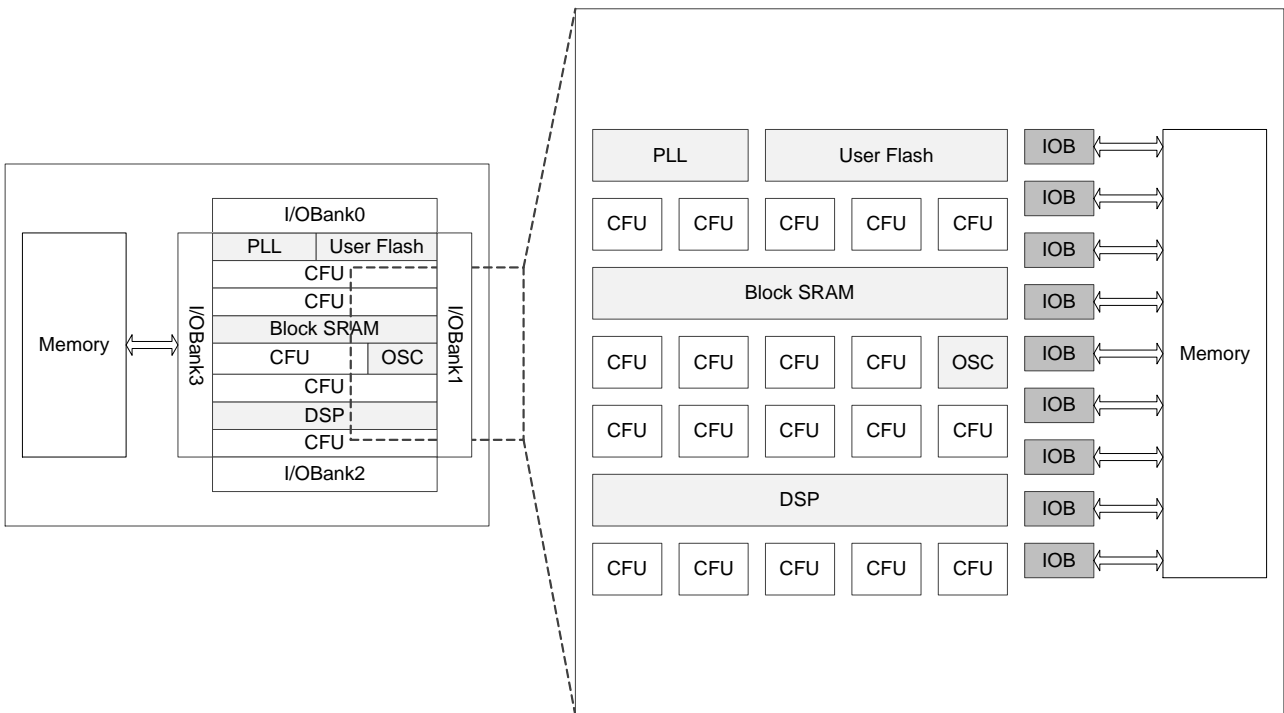

Figure 3-2 GW1NR-2 Architecture Overview

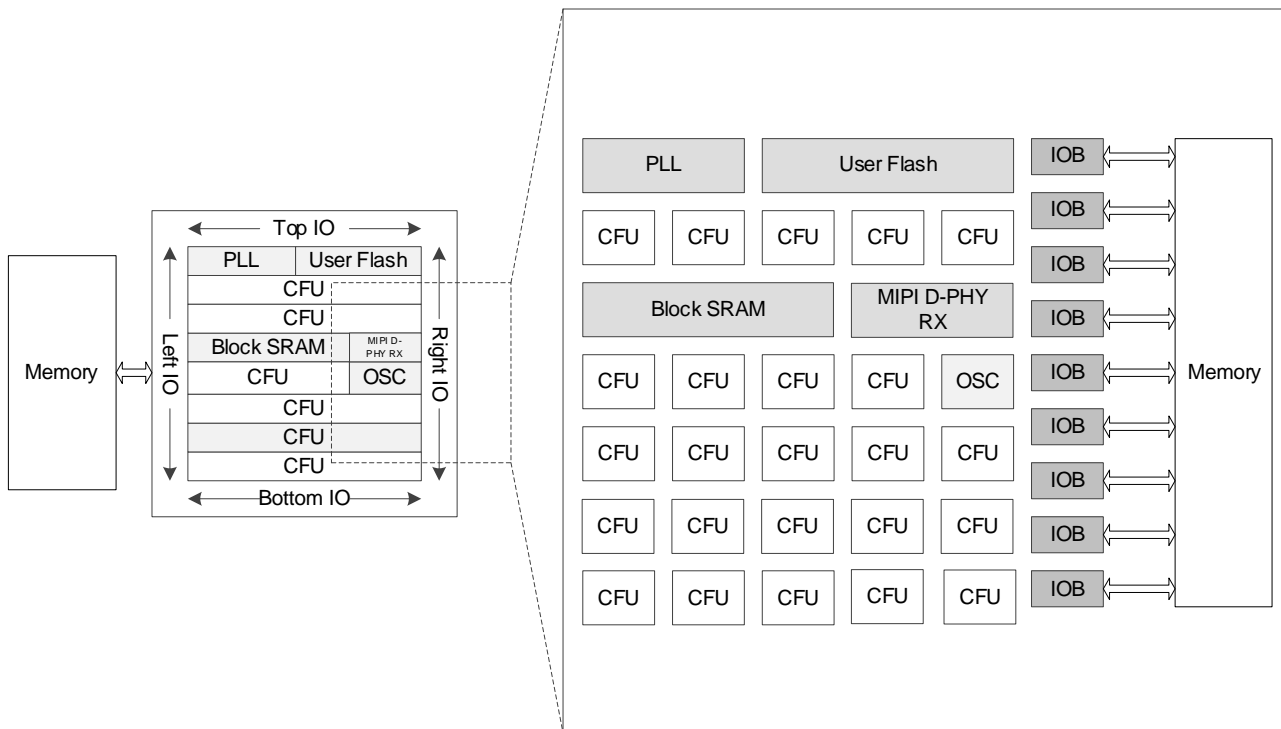

Figure 3-1 presents an overview of the architecture of the GW1NR devices. GW1NR is one form of SIP chip, integrated with the GW1N series of FPGA products and Memory chip. For SDRAM features and overview, see [3.2 Memory](#). Figure 3-2 is the architecture overview of GW1NR-2. MIPI D-PHY RX is also embedded in GW1NR-2. See [Table 2-1](#) for more detailed information.

The core of the GW1NR devices is the array of logic unit surrounded by IO blocks. GW1NR also provides BSRAM, DSP, PLL, user Flash, and on chip oscillator and supports Instant-on. See [Table 2-1](#) for more detailed information on internal resources.

Configurable Function Unit (CFU) is the base cell for the array of the GW1NR series of FPGA Products. Devices with different capacities have different numbers of rows and columns. CFU can be configured as LUT4 mode, ALU mode, and memory mode. Memory mode is supported in GW1NR-6 and GW1NR -9. See [3.3 Configurable Function Unit](#) for more detailed information.

The I/O resources in the GW1NR series of FPGA products are arranged around the periphery of the devices in groups referred to as banks. The I/O resources are connected with SDRAM for data storage. Partial of the I/O resources are bounded out. The I/O resources support multiple level standards, and support basic mode, SRD mode, and generic DDR mode. See [3.4 IOB](#) for more detailed information.

The BSRAM is embedded as a row in the GW1NR series of FPGA products. Each BSRAM has 18,432 bits (18 Kbits) and supports multiple configuration modes and operation modes. See [3.5 Block SRAM \(BSRAM\)](#) for more detailed information.

The User Flash is embedded in the GW1NR series of FPGA products, without loss of data even if power off. See [3.6 User Flash \(GW1NR-1\)](#) and [3.7 User Flash \(GW1NR-2/4/9\)](#) for more detailed information.

The GW1NR series of FPGA products also provide DSP. DSP blocks are embedded as a row in the FPGA array. Each DSP block contains two Macros, and each Macro contains two pre-adders, two multipliers with 18 by 18 inputs, and a three input ALU54. See [3.8 DSP](#) for more detailed information.

Note!

- GW1NR-1 and GW1NR-2 do not support DSP resources.
- GW1NR provides one PLL. PLL blocks provide the ability to synthesize clock frequencies. Frequency adjustment (multiply and division), phase adjustment, and duty cycle can be adjusted using the configuration of parameters. There is an internal programmable on-chip oscillator in each of the GW1NR series of the FPGA product. The on-chip oscillator supports the clock frequencies ranging from 2.5 MHz to 125 MHz, providing the clock resource for the MSPI mode. It also provides a clock resource for user designs with the clock precision reaching $\pm 5\%$. See [3.10 Clock](#), [3.14 On Chip Oscillator](#) for more detailed information.

GW1NR-2 provides the hard core MIPI D-PHY RX IP and also the soft core MIPI D-PHY RX TX IP. For further details, please refer to [3.9 MIPI D-PHY \(GW1NR-2\)](#)

FPGA provides abundant CRUs, connecting all the resources in the FPGA. For example, routing resources distributed in CFU and IOB connect resources in CFU and IOB. Routing resources can automatically be generated by Gowin software. In addition, the GW1NR series of FPGA Products also provide abundant GCLKs, long wires (LW), global set/reset (GSR), and programming options, etc. See [3.10 Clock](#), [3.11 Long Wire \(LW\)](#), [3.12 Global Set/Reset \(GSR\)](#) for more detailed information.

3.2 Memory

Different packages for the GW1NR series of FPGA products have different capacities and types. Please refer to [2.3 Package Information](#) for details.

3.2.1 SDR SDRAM

Features

- Access time: 4.5 ns/4.5 ns
- Clock rate: 200/166/143 MHz
- Data width: 16bits
- Synchronous operation
- Internal pipeline architecture
- Four internal Banks (1024K x 16 bits x 4BANK)
- Programmable mode
 - Column address strobe latency: 2 or 3
 - Burst length: 1, 2, 4, 8 bytes or full page
 - Burst type: sequential mode or interval mode

- Burst-Read-Single-Write
- Burst stop function
- Byte masking function
- Auto refresh and self refresh
- 4,096 refresh cycle / 64 ms
- 3.3V ± 0.3V power supply¹
- LVTTTL Interface

Note!

- For the more detailed information about power supply, please refer to Table 4-2.

Overview

SDRAM integrated in the GW1NR series of FPGA Products is a high-speed CMOS synchronous DRAM containing 64Mb. SDRAM consists of four banks, each BANK with size of 1M x16 bits, and each BANK consists of 4096 rows x 256 columns x 16 bits of memory arrays. Support read-write operation burst mode, accesses start at a selected location and continue for a programmed number of locations in a programmed sequence. The activation command is a must before reading or writing. Read or write burst lengths provide 1, 2, 4, and 8 bytes or full page, with a burst termination option. An auto pre-charge function may be enabled to provide a self-timed row pre-charge that is initiated at the end of the burst sequence. Both the auto- and self- refresh functions are easy to use. Through the use of a programmable mode register; the system can choose the most suitable modes to maximize performance.

The supply voltage for the SDRAM interface is 3.3V; the BANK voltage that connects to the SDRAM needs to be 3.3V. For more details, please refer to Table 4-2.

The IP Core Generator that is integrated into Gowin YunYuan Software supports both built-in and external SDR SDRAM controller IP. This controller IP can be used for the SDRAM power-up, initialization, read calibration, etc., by following the controller read/write timing. For the further detailed information, please refer to [IPUG279, Gowin SDRAM Controller User Guide](#).

3.2.2 PSRAM**Note!**

- The features described below apply to the packages of MG81P, QN88P, LQ144P, MG100P, MG100PF, MG100PT, and MG100PS.

Features

- Clock frequency: 166 MHz, the maximum frequency can be DDR332
- 32Mb storage space for one PSRAM
- Double-edge data transmission
- Data width: 16bits(QN88/LQ144) / 32bits (MG100)
- Read/write data latching (RWDS)
- Temperature compensated refresh
- Partial arrays self-refresh (PASR)
- Hybrid sleep mode

- Deep power down (DPD)
- Drive capability: 35,50,100 and 200 Ohm
- Burst access
- 16/32/64/128 bytes burst mode
- Status/control register
- 1.8V supply voltage¹

Note!

- The features described below apply to the packages of MG100PA, MG49P, and MG49PG.

Features

- Clock rate up to 233MHz, 466MB/s read/write throughput
- 32Mb storage space for one PSRAM
- Partial arrays self-refresh (PASR)
- Data Mask (DM) for write data
- Write burst length, maximum 1024 bytes, minimum 2 bytes

Note!

- For the more information about power supply, please refer to [UG804, GW1NR-1 Pinout](#), [UG805, GW1NR-2 Pinout](#), [UG116, GW1NR-4 Pinout](#) and [UG803, GW1NR-9 Pinout](#).

The power supply for the PSRAM interface is 1.8V; the BANK voltage that connects to the PSRAM needs to be 1.8V. Please refer to Table 4-2 further details.

The IP Core Generator that is integrated into Gowin YunYuan Software supports both built-in and external PSRAM controller IP. This controller IP can be used for the PSRAM power-up, initialization, read calibration, etc., by following the controller read/write timing. For the further detailed information, please refer to [IPUG525, Gowin PSRAM Memory Interface IP User Guide](#).

3.2.3 NOR FLASH

Features

- 4Mb of storage, 256 bytes per page;
- Supports SPI;
- Clock frequency: 100MHz (3.0V ~ 3.6V);
 - Dual Output Data Transfer up to 160Mbits/s ~ 70MHz (2.1V~3.0V)
 - Dual Output Data Transfer up to 120Mbits/s ~ 50MHz (1.65V~2.1V)
 - Dual Output Data Transfer up to 80Mbits/s
- Software/Hardware Write Protection
 - All/Partial write protection via software setting
 - Top/Bottom Block protection
- Minimum 100,000 Program/Erase cycles;
- Fast program/ Erase Speed
 - Page program time: 1.6ms;
 - Sector erase time: 150ms;
 - Block erase time: 0.5s/0.8s;
 - Chip erase time: 6s/3s
- Flexible Architecture

- Sector: 4K byte
- Block: 32/64K byte
- Low power
 - Stand-by current: 0.1uA;
 - Power down current: 0.1uA;
- Security Features
 - 128 bits unique ID for each device;
- Data retention: 20 years

A SPI Nor Flash Interface IP that provides a common command interface has been designed by Gowin. For further detailed information, please refer to [IPUG945, Gowin SPI Nor Flash Interface IP User Guide](#).

3.3 Configurable Function Unit

3.3.1 Introduction

The configurable function unit and the configurable logic unit are two basic units for FPGA core of GOWINSEMI. As shown in Figure 3-3, each unit consists of four configurable logic sections and its configurable routing unit. Each of the three configurable logic sections contains two 4-input LUTs and two registers, and the other one only contains two 4-input LUTs.

Configurable logical sections in CLU cannot be configured as SRAM, but as basic logic, ALU, and ROM. The configurable logic sections in the CFU can be configured as basic logic, ALU, SRAM, and ROM depending on the applications. This section takes CFU as an example to introduce CFU and CLU.

Figure 3-3 CFU View

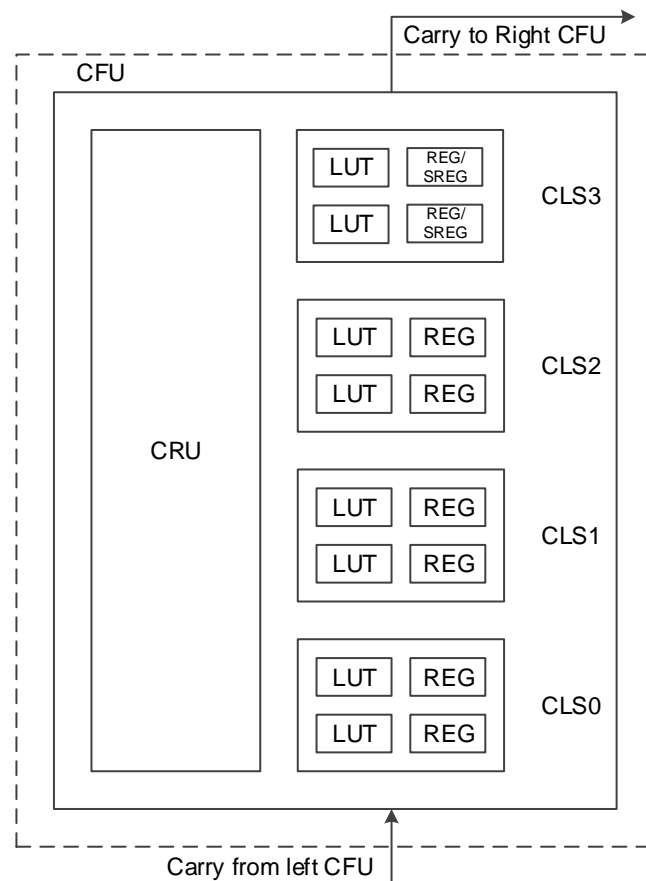

Note!

- SERG needs special patch supporting. Please contact Gowin technical support or local Office for this patch.

For further information of CFU, please refer to [UG288E, Gowin Configurable Function Unit \(CFU\) User Guide](#).

3.3.2 CLU

The CLU supports three operation modes: basic logic mode, ALU

mode, and memory mode.

- Basic Logic Mode

Each LUT can be configured as one four input LUT. A higher input number of LUT can be formed by combining LUT4 together.

- Each CLS can form one five input LUT5.
- Two CLSs can form one six input LUT6.
- Four CLSs can form one seven input LUT7.
- Eight CLSs (two CLUs) can form one eight input LUT8.

- ALU Mode

When combined with carry chain logic, the LUT can be configured as the ALU mode to implement the following functions.

- Adder and subtractor
- Up/down counter
- Comparator, including greater-than, less-than, and not-equal-to
- MULT

- Memory mode

GW1NR-9 supports memory mode. In this mode, a 16 x 4 SSRAM or ROM can be constructed by using CLSs.

This SSRAM can be initialized during the device configuration stage. The initialization data can be generated in the bit stream file from Gowin Yunyuan software.

Register

Each Configurable Logic Section (CLS0~CLS2) has two registers (REG), as shown in Figure 3-4 below.

Figure 3-4 Register in CLS

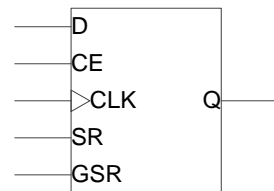

Table 3-1 Register Description in CLS

Signal	I/O	Description
D	I	Data input ^[1]
CE	I	CLK enable, can be high or low effective ^[2]
CLK	I	Clock, can be rising edge or falling edge triggering ^[2]
SR	I	Set/Reset, can be configured as ^[2] : <ul style="list-style-type: none"> ● Synchronized reset ● Synchronized set ● Asynchronous reset ● Asynchronous set ● Non
GSR ^{3,4}	I	Global Set/Reset, can be configured as ^[4] : <ul style="list-style-type: none"> ● Asynchronous reset

Signal	I/O	Description
		<ul style="list-style-type: none">● Asynchronous set● Non
Q	O	Register

Note!

- [1] The source of the signal D can be the output of a LUT, or the input of the CRU; as such, the register can be used alone when LUTs are in use.
- [2] CE/CLK/SR in CFU is independent.
- [3] In the GW1NR series of FPGA products, GSR has its own dedicated network.
- [4] When both SR and GSR are effective, GSR has higher priority.

3.3.3 CRU

The main functions of the CRU are as follows:

- Input selection: Select input signals for the CFU.
- Configurable routing: Connect the input and output of the CFUs, including inside the CFU, CFU to CFU, and CFU to other functional blocks in FPGA.

3.4 IOB

3.4.1 Introduction

The IOB in the GW1NR series of FPGA products includes IO buffer, IO logic, and its routing unit. As shown in Figure 3-5, each IOB connects to two pins (Marked A and B). They can be used as a differential pair or as two single-end input/output.

Figure 3-5 IOB Structure View

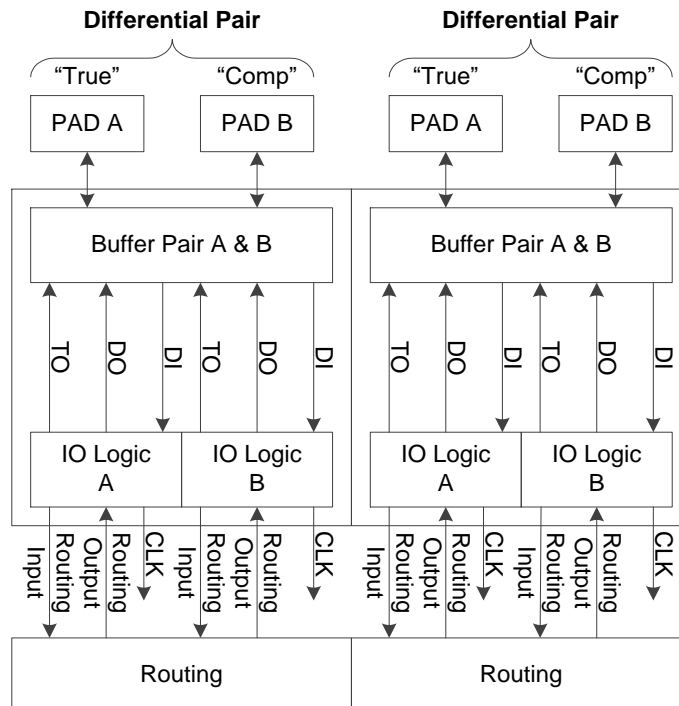

IOB Features:

- V_{CC0} supplied with each bank
- LVCMOS, PCI, LVTTTL, LVDS, SSTL, and HSTL
- Input hysteresis option
- Output drive strength option
- Slew rate option
- Individual bus keeper, weak pull-up, weak pull-down, and open drain option
- Hot socket
- IO logic supports basic mode, SRD mode, and generic DDR mode
- BANK0 of GW1NR-9 supports MIPI Input
- BANK2 of GW1NR-9 supports MIPI Output
- BANK0 and BANK2 of GW1NR-9 support I3C OpenDrain/PushPull conversion

For further information about IOB, please refer to [UG289, Gowin Programmable IO \(GPIO\) User Guide](#).

3.4.2 I/O Buffer

There are four IO Banks in the GW1NR-1/4/9, as shown in Figure 3-6. GW1NR-2 includes seven IO Banks, as shown in Figure 3-7. To support SSTL, HSTL, etc., each bank also provides one independent voltage source (V_{REF}) as referenced voltage. The user can choose from the internal reference voltage of the bank ($0.5 \times V_{CC0}$) or the external reference voltage using any IO from the bank.

Figure 3-6 GW1NR-1/4/9 I/O Bank Distribution

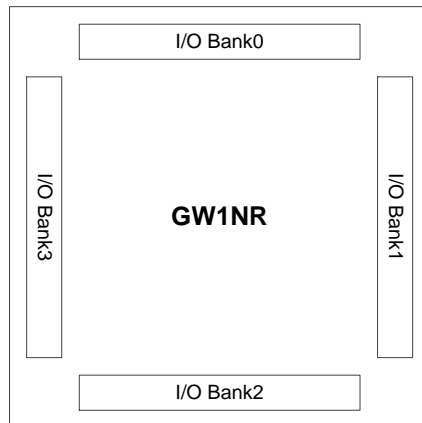
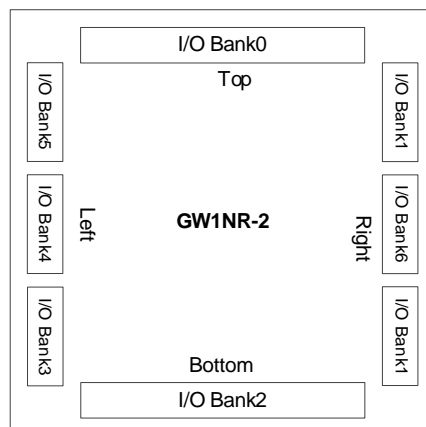

Figure 3-7 GW1NR-2 I/O Bank Distribution



The GW1NR series of FPGA products support LV and UV.

LV devices support 1.2V V_{CC} to meet users' low power needs.

V_{CC0} of LV devices can be set as 1.2V, 1.5V, 1.8V, 2.5V, or 3.3V according to requirements¹.

Linear voltage regulator is integrated in UV devices to facilitate single power supply. The core voltage supports 1.8V, 2.5V, and 3.3V.

V_{CCX} supports 1.8 V, 2.5 V, or 3.3 V power supply.

In GW1NR-9 devices, I/O of Bank0 supports MIPI input and I/O of Bank2 supports MIPI output. I/O of Bank0 and Bank2 support MIPI I3C OpenDrain/PushPull conversion.

Note!

- By default, the Gowin Programmable IO is tri-stated weak pull-up.

- For the recommended working conditions for different packages, please refer to [4.1 Operating Conditions](#)

For the V_{CCO} requirements of different I/O standards, see Table 3-2.

Table 3-2 Output I/O Standards and Configuration Options

I/O Type (Output)	Single/Differ	Bank V_{CCO} (V)	Drive Strength (mA)	Application
MIP1 ^[1]	Differ (TLVDS)	1.2	8	Mobile industry processor interface
LVDS25 ^[2]	Differ (TLVDS)	2.5/3.3	3.5/2.5/2/1.25	high-speed point-to-point data transmission
RS25 ^[2]	Differ (TLVDS)	2.5/3.3	2	high-speed point-to-point data transmission
MINILVDS ^[2]	Differ (TLVDS)	2.5/3.3	2	LCD timing driver interface and column driver interface
PPLVDS ^[2]	Differ (TLVDS)	2.5/3.3	3.5	LCD row/column driver
LVDS25E	Differ	2.5	8	high-speed point-to-point data transmission
BLVDS25E	Differ	2.5	16	Multi-point high-speed data transmission
MLVDS25E	Differ	2.5	16	LCD timing driver interface and column driver interface
RS25E	Differ	2.5	8	high-speed point-to-point data transmission
LVPECL33E	Differ	3.3	16	High-speed data transmission
HSTL18D_I	Differ	1.8	8	memory interface
HSTL18D_II	Differ	1.8	8	memory interface
HSTL15D_I	Differ	1.5	8	memory interface
SSTL15D	Differ	1.5	8	memory interface
SSTL18D_I	Differ	1.8	8	memory interface
SSTL18D_II	Differ	1.8	8	memory interface
SSTL25D_I	Differ	2.5	8	memory interface
SSTL25D_II	Differ	2.5	8	memory interface
SSTL33D_I	Differ	3.3	8	memory interface
SSTL33D_II	Differ	3.3	8	memory interface
LVC12D	Differ	1.2	6/2	universal interface
LVC15D	Differ	1.5	8/4	universal interface
LVC18D	Differ	1.8	8/12/4	universal interface

I/O Type (Output)	Single/Differ	Bank V _{CCO} (V)	Drive Strength (mA)	Application
LVC MOS25D	Differ	2.5	8/16/12/4	universal interface
LVC MOS33D	Differ	3.3	8/16/12/4	universal interface
HSTL15_I	Single	1.5	8	memory interface
HSTL18_I	Single	1.8	8	memory interface
HSTL18_II	Single	1.8	8	memory interface
SSTL15	Single	1.5	8	memory interface
SSTL18_I	Single	1.8	8	memory interface
SSTL18_II	Single	1.8	8	memory interface
SSTL25_I	Single	2.5	8	memory interface
SSTL25_II	Single	2.5	8	memory interface
SSTL33_I	Single	3.3	8	memory interface
SSTL33_II	Single	3.3	8	memory interface
LVC MOS12	Single	1.2	4,8	universal interface
LVC MOS15	Single	1.5	4,8	universal interface
LVC MOS18	Single	1.8	4,8,12	universal interface
LVC MOS25	Single	2.5	4,8,12,16	universal interface
LVC MOS33/ LV TTL33	Single	3.3	4,8,12,16,24	universal interface
PCI33	Single	3.3	N/A	PC and embedded system

Note!

- [1] GW1NR-2 Bank0/Bank3/Bank4/Bank5 supports MIPI I/O output; GW1NR-9 Bank2 supports MIPI I/O output.
- [2] GW1NR-1 does not support this I/O type.

Table 3-3 Input I/O Standards and Configuration Options

I/O Type (Input)	Single/Differ	Bank V _{CCO} (V)	HYSTERESIS	Need V _{REF}
MIPI ^[1]	Differ (TLVDS)	1.2	No	No
LVDS25	Differ (TLVDS)	2.5/3.3	No	No
RS DS	Differ (TLVDS)	2.5/3.3	No	No
MINILVDS	Differ (TLVDS)	2.5/3.3	No	No
PPLVDS	Differ (TLVDS)	2.5/3.3	No	No
LVDS25E	Differ	2.5/3.3	No	No
BLVDS25E	Differ	2.5/3.3	No	No
MLVDS25E	Differ	2.5/3.3	No	No
RS DS25E	Differ	2.5/3.3	No	No
LVPECL33E	Differ	3.3	No	No
HSTL18D_I	Differ	1.8/2.5/3.3	No	No
HSTL18D_II	Differ	1.8/2.5/3.3	No	No
HSTL15D_I	Differ	1.5/1.8/2.5/3.3	No	No

I/O Type (Input)	Single/Differ	Bank V _{CCO} (V)	HYSTERESIS	Need V _{REF}
SSTL15D	Differ	1.5/1.8/2.5/3.3	No	No
SSTL18D_I	Differ	1.8/2.5/3.3	No	No
SSTL18D_II	Differ	1.8/2.5/3.3	No	No
SSTL25D_I	Differ	2.5/3.3	No	No
SSTL25D_II	Differ	2.5/3.3	No	No
SSTL33D_I	Differ	3.3	No	No
SSTL33D_II	Differ	3.3	No	No
LVC MOS12D	Differ	1.2/1.5/1.8/2.5/3.3	No	No
LVC MOS15D	Differ	1.5/1.8/2.5/3.3	No	No
LVC MOS18D	Differ	1.8/2.5/3.3	No	No
LVC MOS25D	Differ	2.5/3.3	No	No
LVC MOS33D	Differ	3.3	No	No
HSTL15_I	Single	1.5 or 1.5/1.8/2.5/3.3 ^[2]	No	Yes
HSTL18_I	Single	1.8 or 1.8/2.5/3.3 ^[3]	No	Yes
HSTL18_II	Single	1.8 or 1.8/2.5/3.3 ^[3]	No	Yes
SSTL15	Single	1.5 or 1.5/1.8/2.5/3.3 ^[2]	No	Yes
SSTL18_I	Single	1.8 or 1.8/2.5/3.3 ^[3]	No	Yes
SSTL18_II	Single	1.8 or 1.8/2.5/3.3 ^[3]	No	Yes
SSTL25_I	Single	2.5 or 2.5/3.3 ^[4]	No	Yes
SSTL25_II	Single	2.5 or 2.5/3.3 ^[4]	No	Yes
SSTL33_I	Single	3.3	No	Yes
SSTL33_II	Single	3.3	No	Yes
LVC MOS12	Single	1.2/1.5/1.8/2.5/3.3	Yes	No
LVC MOS15	Single	1.2/1.5/1.8/2.5/3.3	Yes	No
LVC MOS18	Single	1.2/1.5/1.8/2.5/3.3	Yes	No
LVC MOS25	Single	1.2/1.5/1.8/2.5/3.3	Yes	No
LVC MOS33/ LV TTL33	Single	1.2/1.5/1.8/2.5/3.3	Yes	No
PCI33	Single	3.3	Yes	No
LVC MOS33OD25	Single	2.5	No	No
LVC MOS33OD18	Single	1.8	No	No
LVC MOS33OD15	Single	1.5	No	No
LVC MOS25OD18	Single	1.8	No	No
LVC MOS25OD15	Single	1.5	No	No
LVC MOS18OD15	Single	1.5	No	No
LVC MOS15OD12	Single	1.2	No	No
LVC MOS25UD33	Single	3.3	No	No
LVC MOS18UD25	Single	2.5	No	No

I/O Type (Input)	Single/Differ	Bank V _{CCO} (V)	HYSTERESIS	Need V _{REF}
LVC MOS18UD33	Single	3.3	No	No
LVC MOS15UD18	Single	1.8	No	No
LVC MOS15UD25	Single	2.5	No	No
LVC MOS15UD33	Single	3.3	No	No
LVC MOS12UD15	Single	1.5	No	No
LVC MOS12UD18	Single	1.8	No	No
LVC MOS12UD25	Single	2.5	No	No
LVC MOS12UD33	Single	3.3	No	No

Note!

- [1] GW1NR-2 Bank2, GW1NR-2 Bank6 (Hard core), GW1NR-9 Bank0 supports MIPI I/O input.
- [2] When VREF is INTERNAL, the V_{CCO} of this I/O type is 1.5V; when VREF is VREF1_LOAD, the V_{CCO} of this I/O type is 1.5 V/1.8 V/2.5 V/3.3 V.
- [3] When VREF is INTERNAL, the V_{CCO} of this I/O type is 1.8 V; when VREF is VREF1_LOAD, the V_{CCO} of this I/O type is 1.8 V /2.5 V /3.3 V.
- [4] When VREF is INTERNAL, the V_{CCO} of this I/O type is 2.5 V; when VREF is VREF1_LOAD, the V_{CCO} of this I/O type is 2.5 V /3.3 V.

3.4.3 True LVDS Design

Except GW1NR-1, BANK1/2/3 in the GW1NR devices support true LVDS output, but BANK1/2/3 do not support internal 100Ω input differential matched resistance. Bank0 supports internal 100Ω input differential matched resistance. BANK 0/1/2/3 support LVDS25E, MLVDS25E, BLVDS25E, etc.

For more detailed information on true LVDS, please refer to [UG805, GW1NR-2 Pinout, UG116, GW1NR-4 Pinout and UG803, GW1NR-9 Pinout](#).

True LVDS input I/O needs external 100Ω terminal resistance for matching. See Figure 3-8 for the true LVDS design.

Figure 3-8 True LVDS Design

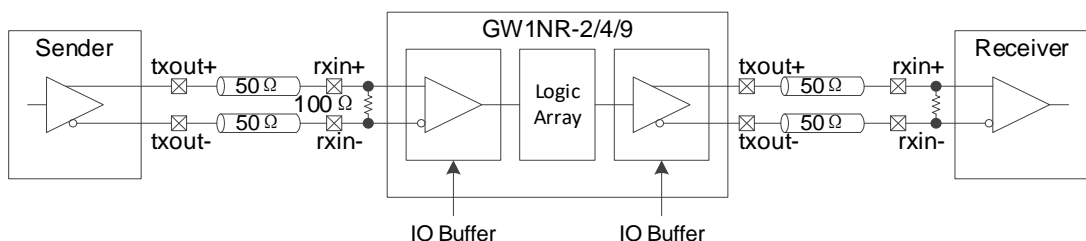

For more detailed information about LVDS25E, MLVDS25E, and BLVDS25E on IO terminal matched resistance, please refer to [UG289, Gowin Programmable IO \(GPIO\) User Guide](#).

3.4.4 I/O Logic

Figure 3-9 shows the I/O logic output of the GW1NR series of FPGA

products.

Figure 3-9 I/O Logic Output

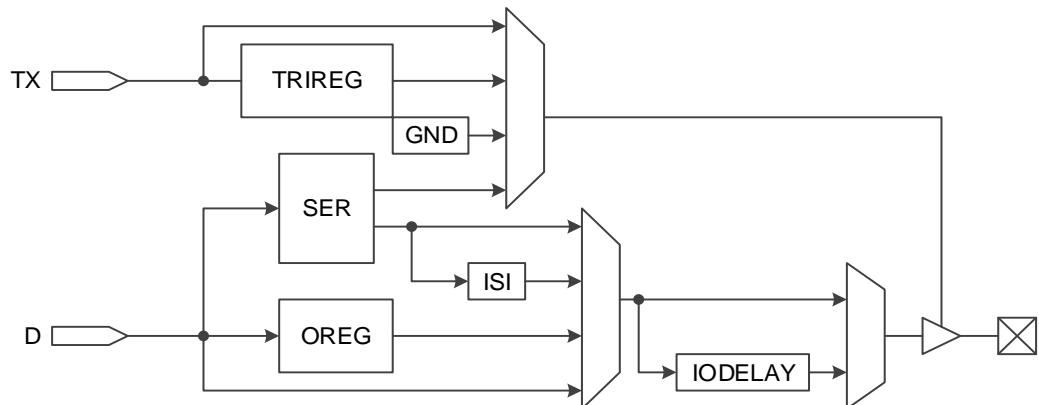

Figure 3-10 shows the I/O logic input of the GW1NR series of FPGA products.

Figure 3-10 I/O Logic Input

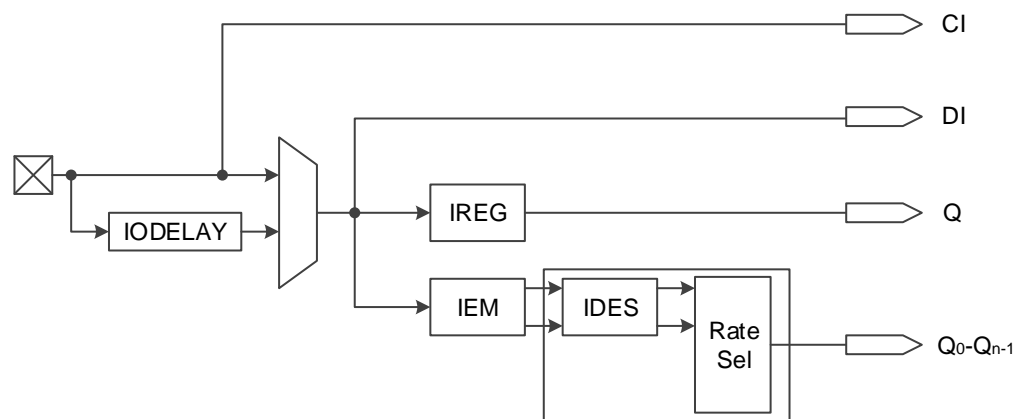

Table 3-1 Port Description

Ports	I/O	Description
CI ^[1]	Input	GCLK input signal. For the number of GCLK input signals, please refer to <i>UG804, GW1NR-1 Pinout, UG805, GW1NR-2 Pinout, UG116, GW1NR-4 Pinout and UG803, GW1NR-9 Pinout.</i>
DI	Input	IO port low-speed input signal, entering into Fabric directly.
Q	Output	IREG output signal in SDR module.
Q ₀ -Q _{n-1}	Output	IDES output signal in DDR module.

Note!

When CI is used as GCLK input, DI, Q, and Q₀-Q_{n-1} cannot be used as I/O input and output.

A description of the I/O logic modules of the GW1NR series of FPGA products is presented below:

IODELAY

See Figure 3-11 for an overview of the IODELAY. Each I/O of the GW1NR series of FPGA products has an IODELAY cell. A total of 128(0~127) step delay is provided, with one-step delay time of about 30ps.

Figure 3-11 IODELAY

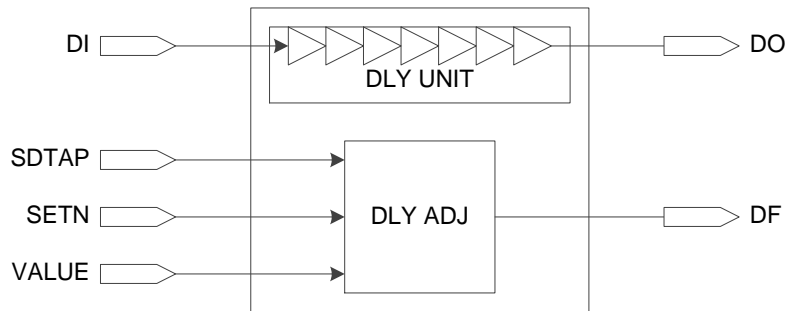

The delay cell can be controlled in two ways:

- Static control:
- Dynamic control: Usually used to sample delay window together with IEM. The IODELAY cannot be used for both input and output at the same time

I/O Register

See Figure Figure 3-12 for the I/O register in the GW1NR series of FPGA products. Each I/O provides one input register (IREG), one output register (OREG), and a tristate Register (TRIREG).

Figure 3-12 Register Structure in I/O Logic

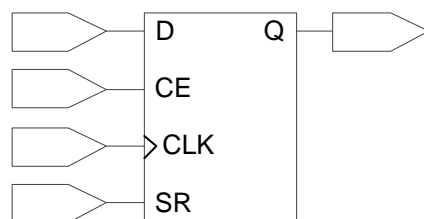

Note!

- CE can be either active low (0: enable) or active high (1: enable).
- CLK can be either rising edge trigger or falling edge trigger.
- SR can be either synchronous/asynchronous SET or RESET or disable.
- The register can be programmed as register or latch.

IEM

IEM is for sampling clock edge and is used in the generic DDR mode. See Figure 3-13 for the IEM structure.

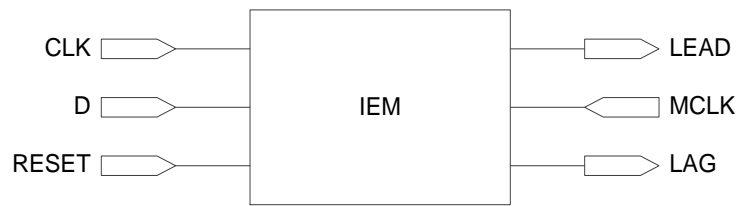
Figure 3-13 IEM Structure**De-serializer DES and Clock Domain Transfer**

The GW1NR series of FPGA products provides a simple serializer SER for each output I/O to support advanced I/O protocols.

Serializer SER

The GW1NR series of FPGA products provides a simple serializer (SER) for each output I/O to support advanced I/O protocols.

3.4.5 I/O Logic Modes

The I/O Logic in the GW1NR series of FPGA products supports several modes. In each operation, the I/O (or I/O differential pair) can be configured as output, input, and INOUT or tristate output (output signal with tristate control).

Not all the device pins support I/O logic. The pins IOL10 (A, B, C ... J) and IOR10 (A, B, C ..., J) of GW1NR-4 do not support IO logic. All GW1NR-9 pins support IO logic.

Basic Mode

In basic mode, the I/O Logic is as shown in Figure 3-14, and the TC, DO, and DI signals can connect to the internal cores directly through CRU.

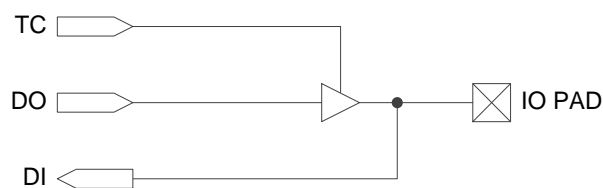
Figure 3-14 I/O Logic in Basic Mode**SDR Mode**

In comparison with the basic mode, SDR utilizes the IO register, as shown in Figure 3-15. This can effectively improve IO timing.

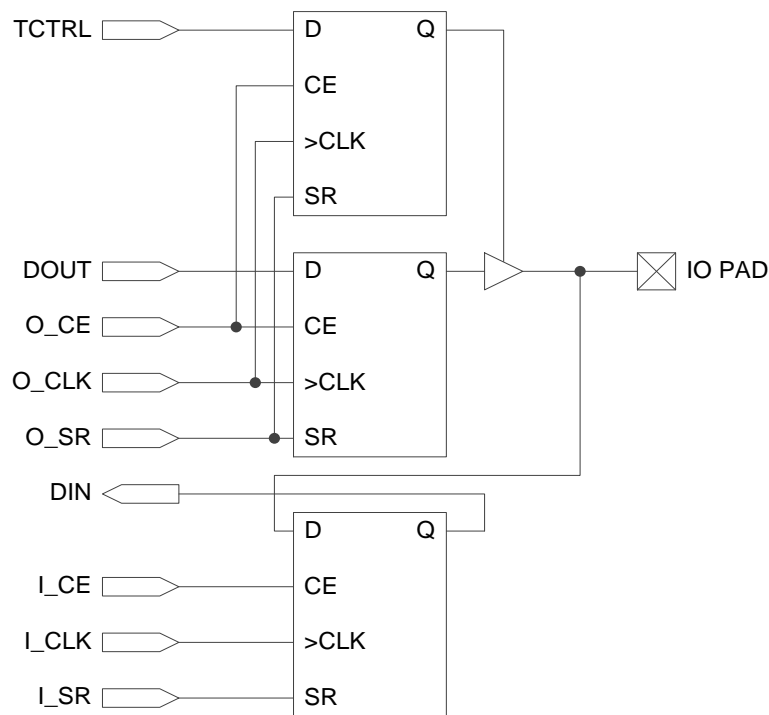
Figure 3-15 I/O Logic in SDR Mode**Note!**

- CLK enable O_CE and I_CE can be configured as active high or active low;
- O_CLK and I_CLK can be either rising edge trigger or falling edge trigger;
- Local set/reset signal O_SR and I_SR can be either synchronized reset, synchronized set, asynchronous reset, asynchronous set, or no-function;
- I/O in SDR mode can be configured as basic register or latch.

Generic DDR Mode

Higher speed I/O protocols can be supported in generic DDR mode. GW1NR-9 devices support IDES16 mode and OSER16 mode. The other devices do not support.

Figure 3-16 shows the generic DDR input, with a speed ratio of the internal logic to PAD 1:2.

Figure 3-16 I/O Logic in DDR Input Mode

Figure 3-17 shows the generic DDR output, with a speed ratio of the PAD to FPGA internal logic 2:1.

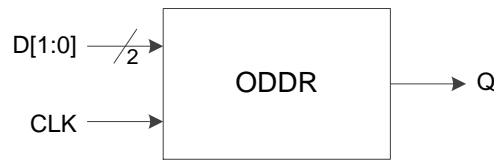
Figure 3-17 I/O Logic in DDR Output Mode**IDES4**

In IDES4 mode, the speed ratio of the PAD to FPGA internal logic is 1:4.

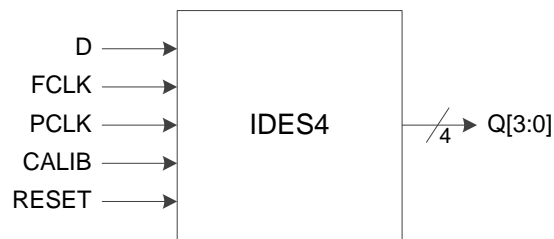
Figure 3-18 I/O Logic in IDES10 Mode**OSER4 Mode**

In OSER4 mode, the speed ratio of the PAD to FPGA internal logic is 4:1.

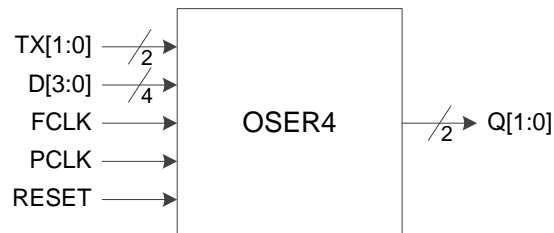
Figure 3-19 I/O Logic in OSER4 Mode**IVideo Mode**

In IVideo mode, the speed ratio of the PAD to FPGA internal logic is 1:7.

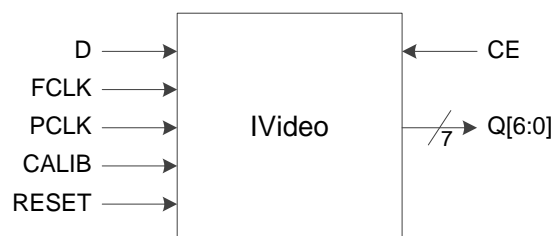
Figure 3-20 I/O Logic in IVideo Mode**Note!**

IVideo and IDES8/10 will occupy the neighboring I/O logic. If the I/O logic of a single port is occupied, the pin can only be programmed in SDR or BASIC mode.

OVideo Mode

In OVideo mode, the speed ratio of the PAD to FPGA internal logic is

7:1.

Figure 3-21 I/O Logic in OVideo Mode

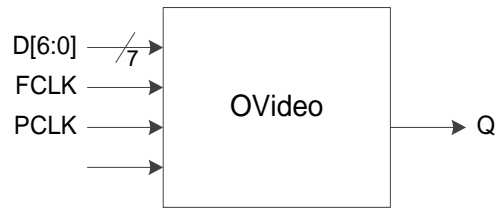

IDES8 Mode

In IDES8 mode, the speed ratio of the PAD to FPGA internal logic is 1:8.

Figure 3-22 I/O Logic in IDES8 Mode

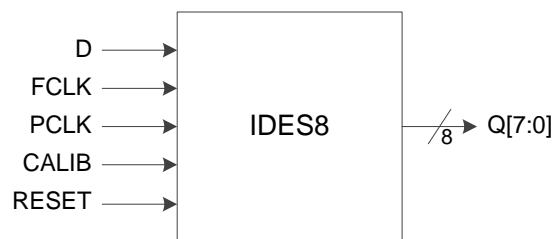

OSER8 Mode

In OSER8 mode, the speed ratio of the PAD to FPGA internal logic is 8:1.

Figure 3-23 I/O Logic in OSER8 Mode

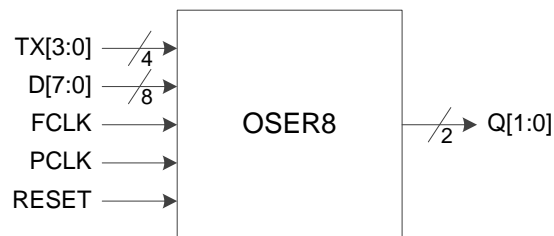

IDES10 Mode

In IDES10 mode, the speed ratio of the PAD to FPGA internal logic is 1:10.

Figure 3-24 I/O Logic in IDES10 Mode

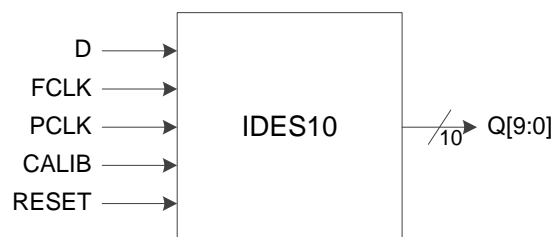

OSER10 Mode

In OSER10 mode, the speed ratio of the PAD to FPGA internal logic is 10:1.

Figure 3-25 I/O Logic in OSER10 Mode

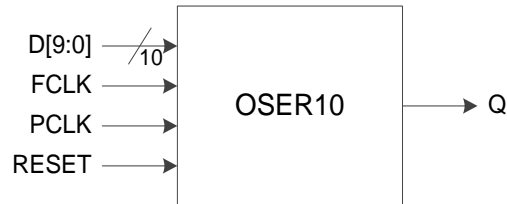

IDES16 Mode

In IDES16 mode, the speed ratio of the PAD to FPGA internal logic is 1:16.

Figure 3-26 I/O Logic in IDES16 Mode

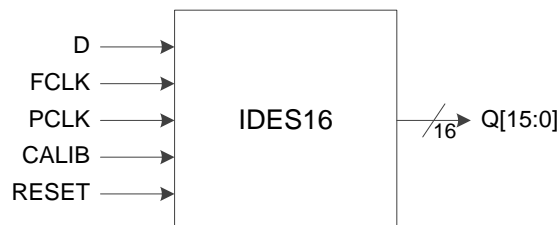

OSER16 Mode

In OSER16 mode, the speed ratio of the PAD to FPGA internal logic is 16:1.

Figure 3-27 I/O Logic in OSER16 Mode

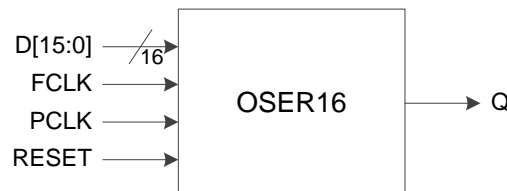

3.5 Block SRAM (BSRAM)

3.5.1 Introduction

GW1NR series FPGA products provide abundant SRAM. The Block SRAM (BSRAM) is embedded as a row in the FPGA array and is different from SSRAM (Shadow SRAM). Each BSRAM has 18,432 bits (18Kbits). There are five operation modes: single port, dual port, semi-dual port, ROM, and FIFO.

An abundance of BSRAM resources provide a guarantee for the user's high-performance design. BSRAM features include the following:

- Max.18,432 bits per BSRAM
- BSRAM itself can run at 190 MHz at max
- Single port
- Dual port

- Semi-dual port
- Parity bits
- ROM
- Data width from 1 to 36 bits
- Mixed clock mode
- Mixed data width mode
- Enable Byte operation for double byte or above
- Normal Read and Write Mode
- Read-before-write Mode
- Write-through Mode

For further details about BSRAM, please refer to [UG285E, Gowin BSRAM & SSRAM User Guide](#).

3.5.2 Configuration Mode

The BSRAM mode in the GW1NR series of FPGA products supports different data bus widths. See Table 3-4.

Table 3-4 Memory Size Configuration

Single Mode	Port	Dual Port Mode ¹	Semi-Dual Mode	Port	Read Only
16K x 1		16K x 1	16K x 1		16K x 1
8K x 2		8K x 2	8K x 2		8K x 2
4K x 4		4K x 4	4K x 4		4K x 4
2K x 8		2K x 8	2K x 8		2K x 8
1K x 16		1K x 16	1K x 16		1K x 16
512 x 32		-	512 x 32		512 x 32
2K x 9		2K x 9	2K x 9		2K x 9
1K x 18		1K x 18	1K x 18		1K x 18
512 x 36		-	512 x 36		512 x 36

Note!

- [1]The GW1NR-9 device does not support Dual Port Mode.

Single Port Mode

In the single port mode, BSRAM can write to or read from one port at one clock edge. During the write operation, the data can show up at the output of BSRAM. Normal-Write Mode and Write-through Mode can be supported. When the output register is bypassed, the new data will show at the same write clock rising edge.

For further information about Single Port Block Memory ports and the related description, please refer to [SUG283E, Gowin Primitives User Guide > 3 Memory](#).

Dual Port Mode

BSRAM support dual port mode. The applicable operations are as follows:

- Two independent read
- Two independent write

- An independent read and an independent write at different clock frequencies

For further information about Dual Port Block Memory ports and the related description, please refer to [SUG283E, Gowin Primitives User Guide](#) > 3 Memory.

Semi-Dual Port Mode

Semi-Dual Port supports read and write at the same time on different ports, but it is not possible to write and read to the same port at the same time. The system only supports write on Port A, read on Port B.

For further information about Semi-Dual Port Block Memory ports and the related description, please refer to [SUG283E, Gowin Primitives User Guide](#) > 3 Memory.

Read Only

BSRAM can be configured as ROM. The ROM can be initialized during the device configuration stage, and the ROM data needs to be provided in the initialization file. Initialization completes during the device power-on process.

Each BSRAM can be configured as one 16 Kbits ROM. For further information about Read Only Port Block Memory ports and the related description, please refer to [SUG283E, Gowin Primitives User Guide](#) > 3 Memory.

3.5.3 Mixed Data Bus Width Configuration

BSRAM in the GW1NR series of FPGA products supports mixed data bus width operation. In the dual port and semi-dual port modes, the data bus width for read and write can be different. For the configuration options that are available, please see Table 3-5 and Table 3-6 below.

Table 3-5 Dual Port Mixed Read/Write Data Width Configuration

Read Port	Write Port						
	16K x 1	8K x 2	4K x 4	2K x 8	1K x 16	2K x 9	1K x 18
16K x 1	*	*	*	*	*		
8K x 2	*	*	*	*	*		
4K x 4	*	*	*	*	*		
2K x 8	*	*	*	*	*		
1K x 16	*	*	*	*	*		
2K x 9						*	*
1K x 18						*	*

Note!

"*" denotes the modes supported.

Table 3-6 Semi Dual Port Mixed Read/Write Data Width Configuration

Read Port	Write Port								
	16K x 1	8K x 2	4K x 4	2K x 8	1K x 16	512 x 32	2K x 9	1K x 18	512 x 36
16K x 1	*	*	*	*	*	*			
8K x 2	*	*	*	*	*	*			
4K x 4	*	*	*	*	*	*			
2K x 8	*	*	*	*	*	*			
1K x 16	*	*	*	*	*	*			
512x32	*	*	*	*	*	*			
2K x 9							*	*	*
1K x 18							*	*	*

Note!

"*" denotes the modes supported.

3.5.4 Byte-enable

The BSRAM in the GW1NR series of FPGA products supports byte-enable. For data longer than a Byte, the additional bits can be blocked, and only the selected portion is allowed to be written into. The blocked bits will be retained for future operation. Read/write enable ports (WREA, WREB), and byte-enable parameter options can be used to control the BSRAM write operation.

3.5.5 Parity Bit

There are parity bits in BSRAMs. The 9th bit in each byte can be used as a parity bit to check the correctness of data transmission. It can also be used for data storage.

3.5.6 Synchronous operation

- All the input registers of BSRAM support synchronous write;
- The output registers can be used as pipeline register to improve design performance;
- The output registers are bypass-able.

3.5.7 Power up Conditions

BSRAM initialization is supported when powering up. During the power-up process, BSRAM is in standby mode, and all the data outputs are "0". This also applies in ROM mode.

3.5.8 BSRAM Operation Modes

BSRAM supports five different operations, including two read operations (Bypass Mode and Pipeline Read Mode) and three write operations (Normal Write Mode, Write-through Mode, and Read-before-write Mode).

Read Mode

Read data from the BSRAM via output registers or without using the registers.

Pipeline Mode

While writing in the BSRAM, the output register and pipeline register are also being written. The data bus can be up to 36 bits in this mode.

Bypass Mode

The output register is not used. The data is kept in the output of the memory array.

Figure 3-28 Pipeline Mode in Single Port, Dual Port and Semi Dual Port

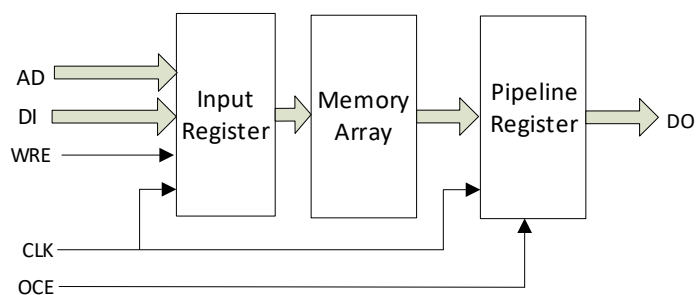

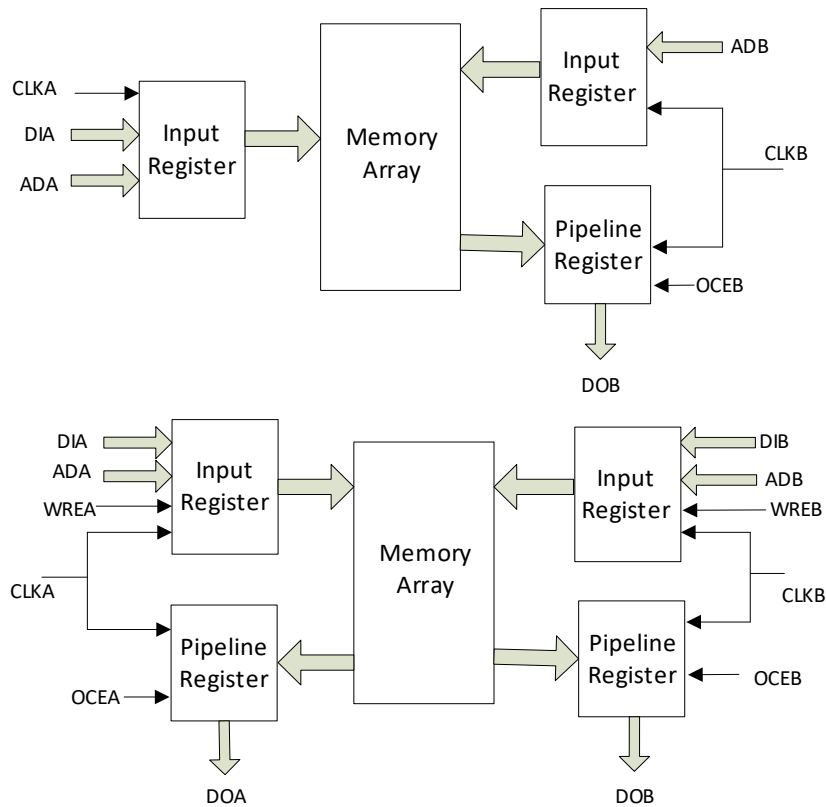

Write Mode

NORMAL WRITE MODE

In this mode, when the user writes data to one port, and the output data of this port does not change. The data written in will not appear at the read port.

WRITE-THROUGH MODE

In this mode, when the user writes data to one port, and the data written in will also appear at the output of this port.

READ-BEFORE-WRITE MODE

In this mode, when the user writes data to one port, and the data written in will be stored in the memory according to the address. The original data in this address will appear at the output of this port.

3.5.9 Clock Operations

Table 3-7 lists the clock operations in different BSRAM modes:

Table 3-7 Clock Operations in Different BSRAM Modes

Clock Operations	Dual Port Mode	Semi-dual Port Mode	Single Port Mode
Independent Clock Mode	Yes	No	No
Read/Write Clock Mode	Yes	Yes	No
Single Port Clock Mode	No	No	Yes

Independent Clock Mode

Figure 3-29 shows the independent clocks in the dual port mode with each port with one clock. CLKA controls all the registers at Port A; CLKB controls all the registers at Port B.

Figure 3-29 Independent Clock Mode

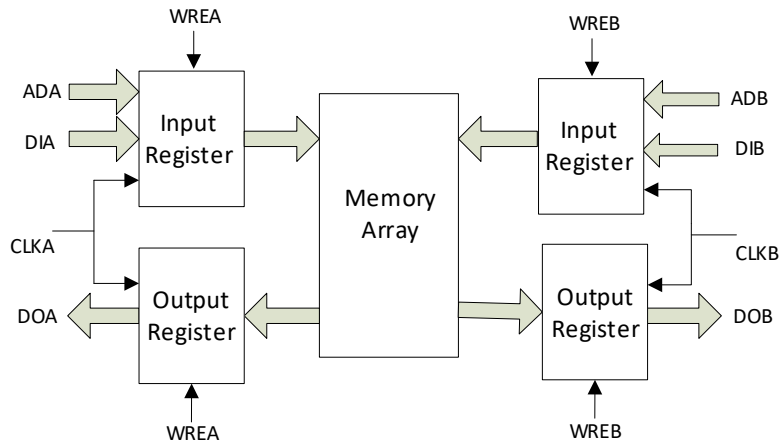

Read/Write Clock Operation

Figure 3-30 shows the read/write clock operations in the semi-dual port mode with one clock at each port. The write clock (CLKA) controls Port A data inputs, write address and read/write enable signals. The read clock (CLKB) controls Port B data output, read address, and read enable signals.

Figure 3-30 Read/Write Clock Mode

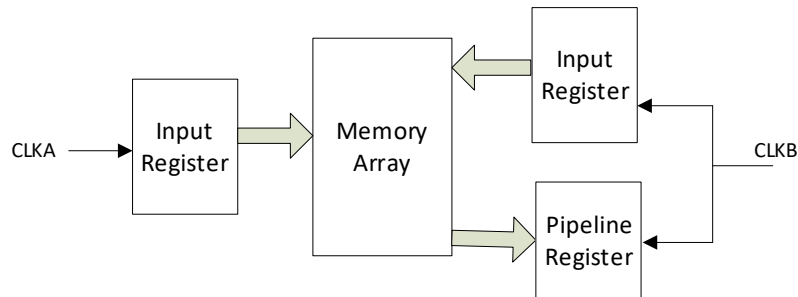

Single Port Clock Mode

Figure 3-31 shows the clock operation in single port mode.

Figure 3-31 Single Port Clock Mode

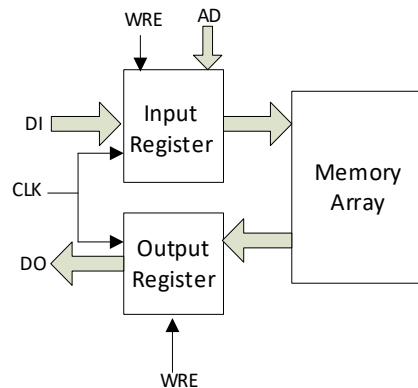

3.6 User Flash (GW1NR-1)

GW1NR-1 devices support User Flash with 12 Kbytes (48 page x 256 Bytes). The features are as following:

- 100,000 write cycles
- Greater than 10 years Data Retention at +85 °C
- Selectable 8/16/32 bits data-in and data-out
- Page size: 256 Bytes
- 3 μA standby current
- Page Write Time: 8.2 ms

For further information about the user Flash in GW1NR-1, please refer to [UG295, Gowin User Flash User Guide](#).

3.7 User Flash (GW1NR-2/4/9)

The GW1NR series of FPGA products support User Flash. The capacity of the user Flash in GW1NR-2 is 96Kbits. The capacity of the user Flash in GW1NR-4 is 256Kbits. The capacity of the user flash in GW1NR-9 is 608Kbits. The user Flash memory is composed of row memory and column memory. One row memory is composed of 64 column memories. The capacity of one column memory is 32 bits, and the capacity of one row memory is $64 \times 32 = 2048$ bits. Page erase is supported, and one page capacity is 2048 bytes, i.e., one page includes 8 rows. The features are shown below:

- 10,000 write cycles
- Greater than 10 years Data Retention at +85 °C
- Data Width: 32
- GW1NR-2 capacity: 48 rows x 64 columns x 32 = 96kbits
- GW1NR-4 capacity: 128 rows x 64 columns x 32 = 256kbits
- GW1NR-9 capacity: 304 rows x 64 columns x 32 = 608kbits
- Page Erase Capability: 2,048 bytes per page
- Fast Page Erasure/Word Programming Operation
- Clock frequency: 40 MHz
- Word Programming Time: $\leq 16 \mu\text{s}$

- Page Erasure Time: ≤ 120 ms
 - Electric current
 - Read current/duration: 2.19 mA/25 ns (V_{CC}) & 0.5 mA/25 ns (V_{CCX}) (MAX)
 - Program / Erase operation: 12/12 mA (MAX)
- For further information of CFU, please refer to [UG295, Gowin User Flash Guide](#).

3.8 DSP

3.8.1 Introduction

The GW1NR series of FPGA products have abundant DSP modules. Gowin DSP solutions can meet user demands for high performance digital signal processing design, such as FIR, FFT, etc. DSP blocks have the advantages of stable timing performance, high-usage, and low-power.

DSP offers the following functions:

- Multiplier with three widths: 9-bit, 18-bit, 36-bit
- 54-bit ALU
- Multipliers cascading to support wider data
- Barrel shifter
- Adaptive filtering through signal feedback
- Computing with options to round to a positive number or a prime number
- Supports pipeline mode and bypass mode

For further information of CFU, please refer to [UG287, Gowin DSP User Guide](#).

Macro

DSP blocks are embedded as a row in the FPGA array. Each DSP block contains two Macro, and each Macro contains two pre-adders, two 18 x 18 bit multipliers, and one three-input ALU.

Figure 3-32 shows the structure of one Macro:

Figure 3-32 DSP Macro

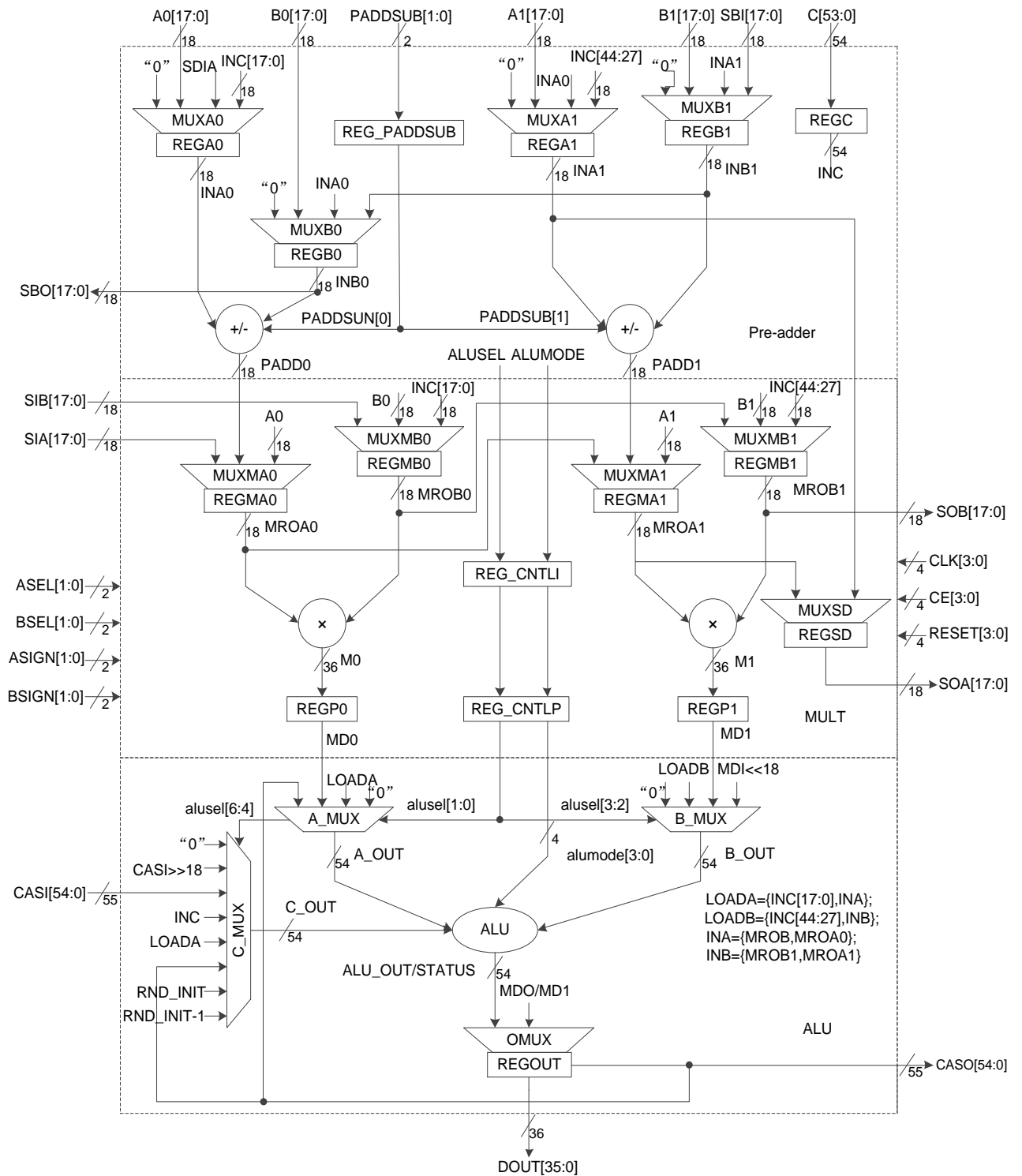

Table 3-8 shows DSP ports description.

Table 3-8 DSP Ports Description

Port Name	I/O	Description
A0[17:0]	I	18-bit data input A0
B0[17:0]	I	18-bit data input B0
A1[17:0]	I	18-bit data input A1
B1[17:0]	I	18-bit data input B1

Port Name	I/O	Description
C[53:0]	I	54-bit data input C
SIA[17:0]	I	Shift data input A, used for CASCADE connection. The input signal SIA is directly connected to the output signal SOA of previously adjacent DSP and the delay from SIA to SOA inside a DSP is one clock cycle.
SIB[17:0]	I	Shift data input B, used for CASCADE connection. The input signal SIB is directly connected to the output signal SOB of previously adjacent DSP and the delay from SIB to SOB inside a DSP is one clock cycle.
SBI[17:0]	I	Pre- adder logic shift input, backward direction.
CASI[54:0]	I	ALU input from previous DSP block, used for cascade connection.
PADDSI0[1:0]	I	Source select for Multiplier or pre-adder input A
BSEL[1:0]	I	Source select for Multiplier input B
ASIGN[1:0]	I	Sign bit for input A
BSIGN[1:0]	I	Sign bit for input B
PADDSUB[1:0]	I	Operation control signals of pre-adder, used for pre-adder logic add/subtract selection
CLK[3:0]	I	Clock input
CE[3:0]	I	Clock Enable
RESET[3:0]	I	Reset input, synchronous or asynchronous
SOA[17:0]	O	Shift data output A
SOB[17:0]	O	Shift data output B
SBO[17:0]	O	Pre- adder logic shift output, backward direction.
DOUT[35:0]	O	DSP output data
CASO[54:0]	O	ALU output to next DSP block for cascade connection, the highest bit is sign-extended.

Table 3-9 Internal Registers Description

Register	Description and Associated Attributes
A0 register	Registers for A0 input
A1 register	Registers for A1 input
B0 register	Registers for B0 input
B1 register	Registers for B1 input
C register	C register
P1_A0 register	Registers for A0 input of left multiplier
P1_A1 register	Registers for A1 input of right multiplier
P1_B0 register	Registers for B0 input of left multiplier
P1_B1 register	Registers for B1 input of right multiplier
P2_0 register	Registers for pipeline of left multiplier
P2_1 register	Registers for pipeline of right multiplier
OUT register	Registers for DOUT output
OPMODE register	Registers for operation mode control
SOA register	Registers for shift output at port SOA

PADD

Each DSP macro features two units of pre-adders to implement pre-add, pre-subtraction, and shifting.

PADD locates at the first stage with two inputs:

- Parallel 18-bit input B or SBI;
 - Parallel 18-bit input A or SIA.
- Each input end supports pipeline mode and bypass mode. GOWINSEMI PADD can be used as function block independently, which supports 9-bit and 18-bit width.

MULT

Multipliers locate after the pre-adder. Multipliers can be configured as 9 x 9, 18 x 18, 36 x 18 or 36 x 36. Pipeline Mode and Bypass Mode are supported both in input and output ports. The configuration modes that a macro supports include:

- One 18 x 36 multiplier
- Two 18 x 18 multipliers
- Four 9 x 9 multipliers

Two adjacent DSP macros can form a 36 x 36 multiplier.

ALU

Each Macro has one 54 bits ALU54, which can further enhance MULT's functions. Registered Mode and Bypass Mode are supported both in input and output ports. The functions are as following:

- Multiplier output data / 0, addition/subtraction operations for data A and data B;
- Multiplier output data / 0, addition/subtraction operations for data B and bit C;
- Addition/subtraction operations for data A, data B, and bit C;

3.8.2 DSP Operations

- Multiplier
- Accumulator
- MULTADDALU

For further information about DSP, please refer to [UG287, Gowin DSP User Guide](#).

3.9 MIPI D-PHY (GW1NR-2)

Hard Core - MIPI D-PHY RX

GW1NR-2 provides provides a standalone MIPI RX D-PHY supporting the v2.1 specification of MIPI Alliance Standard. The dedicated D-PHY core supports MIPI DSI and CSI-2 mobile video interfaces for cameras and displays.

Features are as follows:

- High Speed RX at up to 8 Gbps per quad
- 1, 2 or 4 data lane and 1 clock lane support per PHY
- Bidirectional Low-power (LP) mode at up to 10mbps per lane
- Built-in HS Sync, bit and lane alignment
- 1:8 and 1:16 deserialization modes to FPGA fabric's user interface
- Supports MIPI DSI and MIPI CSI-2 link layers
- Available on bank 6

Multi-function Highspeed FPGA IO support for MIPI D-PHY RX/TX

GW1NR-2 also provides flexible highspeed FPGA IO which supports both MIPI D-PHY RX and TX interfaces. Highspeed FPGA IO supports MIPI DSI and CSI-2 video interfaces for cameras and displays in both transmit and receive modes.

Features are as follows:

- MIPI Alliance Standard for D-PHY Specification, Version 1.2
- High Speed RX and TX at up to 6 Gbps per port
- 1, 2 or 4 data lane and 1 clock lane support per PHY
- Multiple PHY support (number of IO permitting)
- Bidirectional Low-power (LP) mode
- Supports MIPI DSI and MIPI CSI-2 link layers
- Built-in HS Sync, bit and lane alignment
- 1:8 and 1:16 deserialization modes to FPGA fabric's user interface
- Supports multiple IO Types
 - ELVDS, TLVDS, SLVS200, LVDS and MIPI D-PHY IO
- MIPI D-PHY TX with dynamic ODT supported on IO banks 0, 3, 4 and 5
- MIPI D-PHY RX with dynamic ODT supported on IO bank 2

For further detailed information, please refer to [IPUG948, Gowin MIPI D-PHY RX TX Advance User Guide](#).

3.10 Clock

The clock resources and wiring are critical for high-performance applications in FPGA. The GW1NR series of FPGA products provide the global clock network (GCLK) which connects to all the registers directly. Besides the global clock network, the GW1NR series of FPGA products provide high-speed clock HCLK. PLL, etc are also provided.

For further information of CFU, please refer to [UG286, Gowin Clock User Guide](#).

3.10.1 Global Clock

The GCLK is distributed in GW1NR series of FPGA products as two quadrants, L and R. Each quadrant provides eight GCLKs. The optional clock resources of GCLK can be pins or CRU. Users can employ dedicated pins as clock resources to achieve better timing.

3.10.2 PLL

Phase-locked Loop (PLL) is one kind of a feedback control circuit. The frequency and phase of the internal oscillator signal is controlled by the external input reference clock.

PLL blocks provide the ability to synthesize clock frequencies. Frequency adjustment (multiply and division), phase adjustment, and duty cycle can be adjusted by configuring the parameters.

GW1NR-1/4/9

See Figure 3-33 for the PLL structure.

Figure 3-33 PLL Structure (GW1NR-1/4/9)

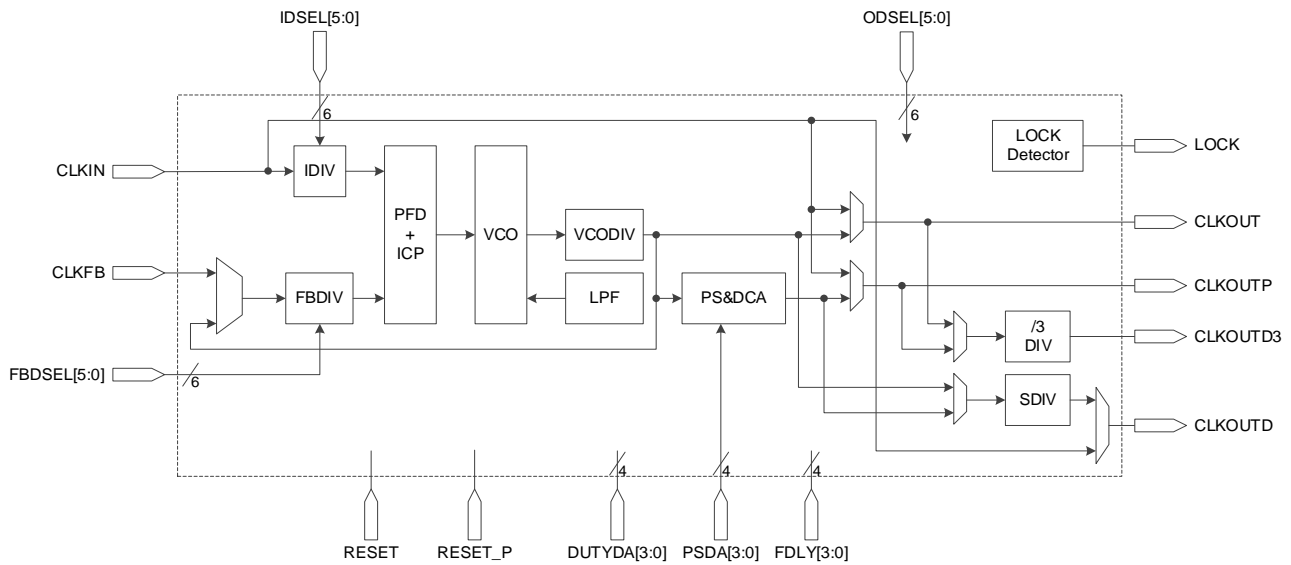

Table 3-10 PLL Ports Definition

Port Name	Signal	Description
CLKIN [5:0]	I	Reference clock input
CLKFB	I	Feedback clock input
RESET	I	PLL reset
RESET_P	I	PLL Power Down
INSEL[2:0]	I	Dynamic clock control selector: 0~5
IDSEL [5:0]	I	Dynamic IDIV control: 1~64
FBDSEL [5:0]	I	Dynamic FB DIV control: 1~64
PSDA [3:0]	I	Dynamic phase control (rising edge effective)
DUTYDA [3:0]	I	Dynamic duty cycle control (falling edge effective)
FDLY[3:0]	I	CLKOUTP dynamic delay control
CLKOUT	O	Clock output with no phase and duty cycle adjustment
CLKOUTP	O	Clock output with phase and duty cycle adjustment
CLKOUTD	O	Clock divider from CLKOUT and CLKOUTP (controlled by SDIV)
CLKOUTD3	O	clock divider from CLKOUT and CLKOUTP (controlled by DIV3 with the constant division value 3)
LOCK	O	PLL lock status: 1: locked, 0: unlocked

The PLL reference clock source can come from an external PLL pin or from internal routing GCLK, HCLK, or general data signal. PLL feedback signal can come from the external PLL feedback input or from internal

routing GCLK, HCLK, or general data signal.

For PLL features, please refer to Table 4-21 PLL Switching Characteristics.

PLL can adjust the frequency of the input clock CLKIN (multiply and division). The formulas for doing so are as follows:

1. $f_{CLKOUT} = (f_{CLKIN} * FBDIV) / IDIV$
2. $f_{VCO} = f_{CLKOUT} * ODIV$
3. $f_{CLKOUTD} = f_{CLKOUT} / SDIV$
4. $f_{PFD} = f_{CLKIN} / IDIV = f_{CLKOUT} / FBDIV$

Note!

- f_{CLKIN} : The frequency of the input clock CLKIN
- f_{CLKOUT} : The clock frequency of CLKOUT and CLKOUTP
- $f_{CLKOUTD}$: The clock frequency of CLKOUTD, and CLKOUTD is the clock CLKOUT after division
- f_{PFD} : PFD Phase Comparison Frequency, and the minimum value of f_{PFD} should be no less than 3MHz.

Adjust IDIV, FBDIV, ODIV, and SDIV to achieve the required clock frequency.

GW1NR-2

See Figure 3-34 for the PLL structure of GW1NR-2.

Figure 3-34 PLL Structure (GW1NR-2)

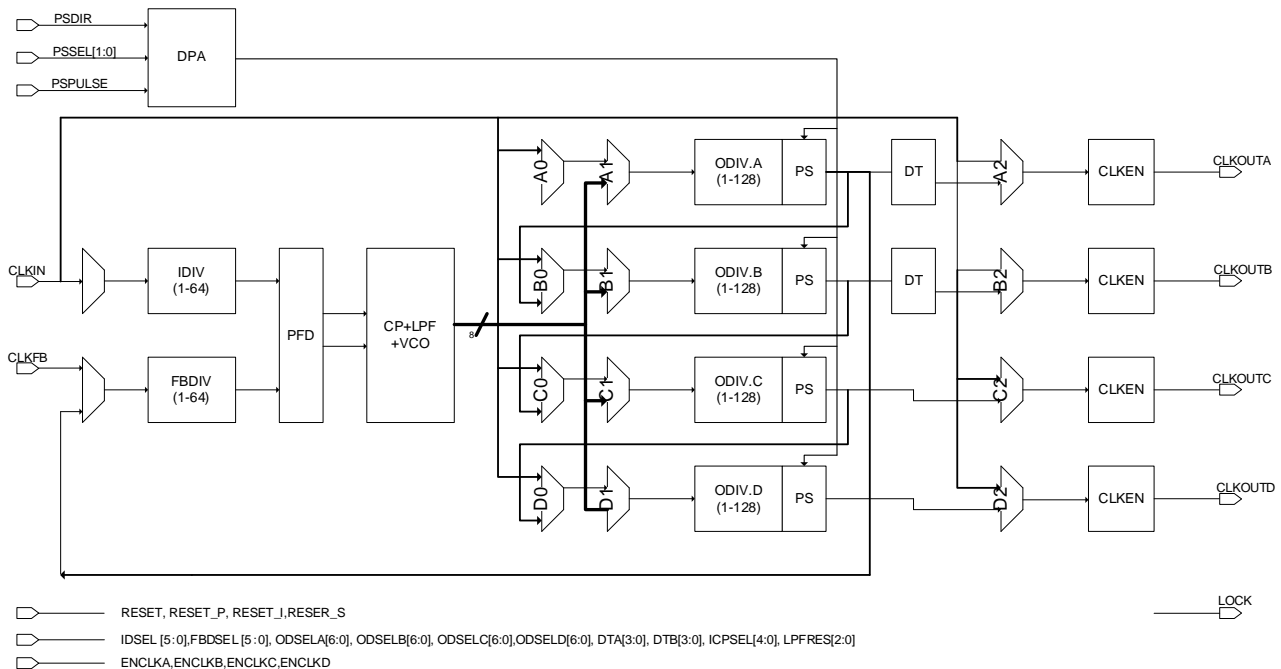

See Table 3-11 for a definition of the PLL ports.

Table 3-11 PLL Ports Definition

Port Name	Signal	Description
CLKIN	I	Reference clock input
CLKFB	I	Feedback clock input

Port Name	Signal	Description
RESET	I	PLL reset
RESET_P	I	PLL Power Down
RESET_I	I	PLL with IDIV reset
RESET_S	I	Only Channel B/C/D reset
IDSEL [5:0]	I	Dynamic IDIV control: 1~64
FBDSEL [5:0]	I	Dynamic FBDIV control:1~64
ODSELA[6:0]	I	Dynamic ODIVA control:1~128
ODSELB[6:0]	I	Dynamic ODIVB control:1~128
ODSELC[6:0]	I	Dynamic ODIVC control:1~128
ODSELD[6:0]	I	Dynamic ODIVD control:1~128
DTA[3:0]	I	Dynamic control of CLKOUTA dutycycle
DTB[3:0]	I	Dynamic control of CLKOUTB dutycycle
ICPSEL[4:0]	I	Dynamic control of ICP size
LPFRES[2:0]	I	Dynamic control LPFRES size
PSDIR	I	Dynamic control of phase shift direction
PSSEL[1:0]	I	Dynamic control of phase shift channel selection
PSPULSE	I	Dynamic control of phase shift clock
ENCLKA ENCLKB ENCLKC ENCLKD	O	Dynamic control of clock output enable
CLKOUTA	O	Clock output of Channel A (by default)
CLKOUTB	O	Clock output of Channel B (by default)
CLKOUTC	O	Clock output of Channel C (by default)
CLKOUTD	O	Clock output of Channel D (by default)

The PLL reference clock source can come from an external PLL pin or from internal routing GCLK, HCLK, or general data signal. PLL feedback signal can come from the external PLL feedback input or from internal routing GCLK, HCLK, or general data signal.

For PLL features of GW1NR-2, please refer to Table 4-21 PLL Switching Characteristics.

PLL can adjust the frequency of the input clock CLKIN (multiplication and division). The formulas for doing so are as follows:

1. $f_{CLKOUTA} = (f_{CLKIN} * FBDIV) / IDIV$
2. $f_{VCO} = f_{CLKOUTA} * ODIVA$
3. $f_{CLKOUTx} = f_{IN_ODIVx} / ODIVx$
4. $f_{PFD} = f_{CLKIN} / IDIV = f_{CLKOUTA} / FBDIV$

Note!

- f_{CLKIN} : The frequency of the input clock CLKIN
- $f_{CLKOUTx}$: The output clock frequency of channel X, x=A/B/C/D.

- ODIV_x: The Output frequency division coefficient of channel X, x=A/B/C/D.
- f_{IN_ODIVx}: The input clock frequency of ODIV_x, x=A/B/C/D, and f_{vco} is defaulted. It's determined by the actual circuit if the Chanel is cascaded.
- f_{PPFD}: PFD Phase Comparison Frequency, and the minimum value of f_{PPFD} should be no less than 3MHz.

Adjust IDIV, FBDIV, and ODIV to achieve the required clock frequency.

3.10.3 HCLK

HCLK is the high-speed clock in the GW1NR series of FPGA products. It can support high-performance data transfer and is mainly suitable for source synchronous data transfer protocols. For HCLK distribution views, see Figure 3-35, Figure 3-36, Figure 3-37, and Figure 3-38.

Figure 3-35 GW1NR-1 HCLK Distribution

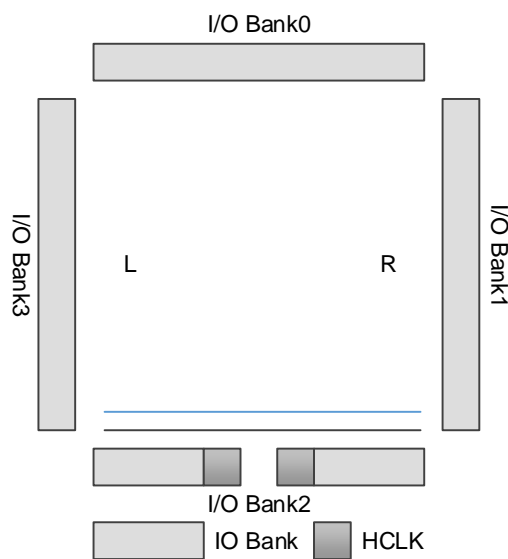

Figure 3-36 GW1NR-2 HCLK Distribution

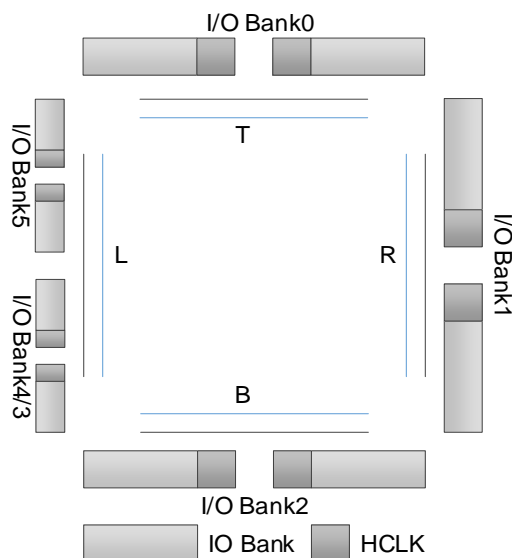

Figure 3-37 GW1NR-4 HCLK Distribution

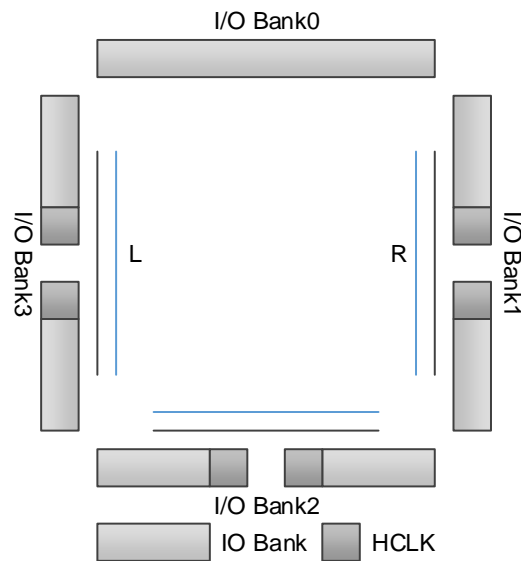
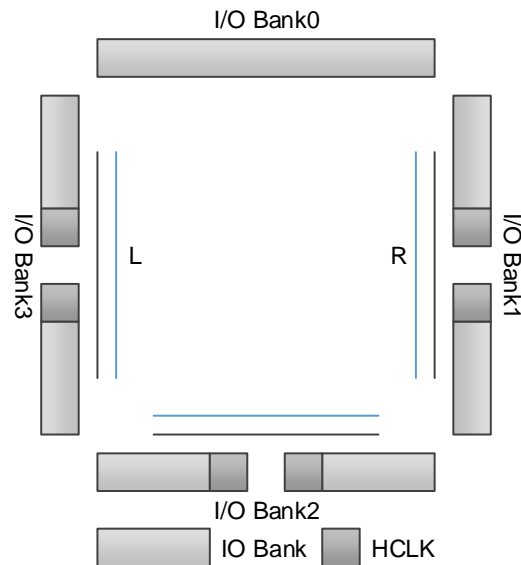

Figure 3-38 GW1NR-9 HCLK Distribution



3.11 Long Wire (LW)

As a supplement to the CRU, the GW1NR series of FPGA products provides another routing resource, Long wire, which can be used as clock, clock enable, set/reset, or other high fan out signals.

3.12 Global Set/Reset (GSR)

A global set/reset (GSR) network is built into the GW1NR series of FPGA product. There is a direct connection to core logic. It can be used as asynchronous/synchronous set or asynchronous/synchronous reset, registers in CFU and I/O can be configured independently.

3.13 Programming Configuration

The GW1NR series of FPGA products support SRAM and Flash. The Flash programming mode supports on-chip Flash and off-chip Flash. The GW1NR series of FPGA products support DUAL BOOT, providing a selection for users to backup data to off chip Flash according to requirements.

Besides JTAG, the GW1NR series of FPGA products also supports GOWINSEMI's own configuration mode: GowinCONFIG (AUTO BOOT, SSPI, MSPI, DUAL BOOT, SERIAL, and CPU). All the devices support JTAG and AUTO BOOT. For the detailed information, please refer to [UG290, Gowin FPGA Products Programming and Configuration Guide](#).

3.13.1 SRAM Configuration

When you adopt SRAM to configure the device, every time the device is powered on, the bit stream file needs to be downloaded to configure the device.

3.13.2 Flash Configuration

The Flash configuration data is stored in the on-chip flash. Each time the device is powered on, the configuration data is transferred from the Flash to the SRAM, which controls the working of the device. This mode can complete configuration within a few ms, and is referred to as "Quick Start".

B version of GW1NR devices has the feature of transparent transmission. That is to say, the B version device can program the on-chip Flash or off-chip Flash via the JTAG interface without affecting the current working state. During programming, the B version device works according to the previous configuration. After programming, provide one low pulse for RECONFIG_N to complete the online upgrade. This feature applies to the applications with long online time and irregular upgrades.

The GW1NR series of FPGA products also support off-chip Flash configuration and dual-boot. Please refer to [UG290, Gowin FPGA Products Programming and Configuration Guide](#) for more detailed information.

3.14 On Chip Oscillator

There is an internal oscillator in each of the GW1NR series of FPGA product. During the configuration process, it can provide a clock for the MSPI mode.

The on-chip oscillator also provides a clock resource for user designs. Up to 64 clock frequencies can be obtained by setting the parameters.

The following formula is employed to get the output clock frequency for GW1NR-1 devices:

$$f_{\text{out}}=240\text{MHz}/\text{Param}$$

The following formula is employed to get the output clock frequency for GW1NR-4 device:

$$f_{out}=210\text{MHz}/\text{Param}$$

The following formula is employed to get the output clock frequency for GW1NR-2/9 devices:

$$f_{out}=250\text{MHz}/\text{Param}$$

Note!

- “Param” is the configuration parameter with a range of 2~128. It supports even number only.
See Table 3-12, Table 3-13, and Table 3-14 for the output frequency.

Table 3-12 GW1NR-1 Oscillator Output Frequency Options

Mode	Frequency	Mode	Frequency	Mode	Frequency
0	2.4MHz ^[1]	8	7.5MHz	16	15MHz
1	5.2MHz	9	8MHz	17	17MHz
2	5.5MHz	10	8.6MHz	18	20MHz
3	5.7MHz	11	9MHz	19	24MHz
4	6MHz	12	10MHz	20	20MHz
5	6.3MHz	13	11MHz	21	40MHz
6	6.7MHz	14	12MHz	22	60MHz
7	7MHz	15	13MHz	23	120MHz ^[2]

Table 3-13 GW1NR-4 Oscillator Output Frequency Options

Mode	Frequency	Mode	Frequency	Mode	Frequency
0	2.1MHz ^[1]	8	6.6MHz	16	13.1MHz
1	4.6MHz	9	7MHz	17	15MHz
2	4.8MHz	10	7.5MHz	18	17.5MHz
3	5MHz	11	8.1MHz	19	21MHz
4	5.3MHz	12	8.8MHz	20	26.3MHz
5	5.5MHz	13	9.5MHz	21	35MHz
6	5.8MHz	14	10.5MHz	22	52.5MHz
7	6.2MHz	15	11.7MHz	23	105MHz ^[2]

Table 3-14 GW1NR-2/9 Oscillator Output Frequency Options

Mode	Frequency	Mode	Frequency	Mode	Frequency
0	2.5MHz ¹	8	7.8MHz	16	15.6MHz
1	5.4MHz	9	8.3MHz	17	17.9MHz
2	5.7MHz	10	8.9MHz	18	21MHz
3	6.0MHz	11	9.6MHz	19	25MHz
4	6.3MHz	12	10.4MHz	20	31.3MHz
5	6.6MHz	13	11.4MHz	21	41.7MHz
6	6.9MHz	14	12.5MHz	22	62.5MHz

Mode	Frequency	Mode	Frequency	Mode	Frequency
7	7.4MHz	15	13.9MHz	23	125MHz ²

Note!

- [1] Default Frequency.
- [2] 125MHz is not suitable for MSPI programming mode.

4 AC/DC Characteristics

Note!

- Users should ensure GOWINSEMI products are always used within recommended operating conditions and range. Data beyond the working conditions and range are for reference only. GOWINSEMI does not guarantee that all devices will operate as expected beyond the standard operating conditions and range.

4.1 Operating Conditions

4.1.1 Absolute Max. Ratings

Table 4-1 Absolute Max. Ratings

Name	Description	Min.	Max.
V _{CC}	LV: Core Power	-0.5V	1.32V
	UV: Core Power	-0.5V	3.75V
V _{CC0}	I/O Bank Power	-0.5V	3.75V
V _{CCX}	Auxiliary Power	-0.5V	3.75V
Storage Temperature	Storage Temperature	-65 °C	+150 °C
Junction Temperature	Junction Temperature	-40 °C	+125 °C

4.1.2 Recommended Operating Conditions

Table 4-2 Recommended Operating Conditions

Name	Description	Min.	Max.
V _{CC}	LV: Core Power	1.14V	1.26V
	UV:Core Power	1.71V	3.6V
V _{CC0x}	I/O Bank Power	1.14V	3.6V
V _{CCX}	Auxiliary voltage	2.375V	3.6V
T _{JCOM}	Junction temperature Commercial operation	0°C	+85°C
T _{JIND}	Junction temperature Industrial operation	-40°C	+100°C

Note!

- For the power supply of different packages, please refer to [UG804, GW1NR-1 Pinout](#), [UG805, GW1NR-2 Pinout](#), [UG116, GW1NR-4 Pinout](#) and [UG803, GW1NR-9 Pinout](#).

4.1.3 Power Supply Ramp Rates

Table 4-3 Power Supply Ramp Rates

Name	Description	Device	Min.	Typ.	Max.
T _{RAMP}	Power supply ramp rates for core voltage	GW1NR-1	1.2mV/μs	-	40mV/μs
		GW1NR-2/4/9	0.6mV/μs	-	6mV/μs
T _{RAMP_VCCx}	Power supply ramp rates for VCCX	GW1NR	0.6mV/μs	-	10mV/us
T _{RAMP_VCCIO}	Power supply ramp rates for VCCIO	GW1NR	0.6mV/μs	-	10mV/us

Name	Description	Min.	Typ.	Max.
T _{RAMP}	Power supply ramp rates for all power supplies	0.6mV/μs	-	6mV/μs

4.1.4 Hot Socket Specifications

Table 4-4 Hot Socket Specifications

Name	Description	Condition	I/O	Max.
I _{HS}	Input or I/O leakage current	0<V _{IN} <V _{IH} (MAX)	I/O	150uA
I _{HS}	Input or I/O leakage current	0<V _{IN} <V _{IH} (MAX)	TDI,TDO, TMS,TCK	120uA

4.1.5 POR Characteristics

Table 4-5 POR Characteristics

Name	Description	Name	Min.	Max.
POR Voltage	Power on reset voltage of V _{cc}	VCC	0.75	1
		VCCX	1.8	2
		VCCIO	0.85	0.98

4.2 ESD

Table 4-6 GW1NR ESD - HBM

Device	GW1NR-1	GW1NR-2	GW1NR-4	GW1NR-9
QN88	-	-	HBM>1,000V	HBM>1,000V
MG49P/MG49G/MG49PG	-	HBM>1,000V		
MG81	-	-	HBM>1,000V	-
MG100P/MG100PF/MG100PA/ MG100PT/ MG100PS	-	-	-	HBM>1,000V
LQ100G	HBM>1,000V	-	-	-
LQ144	-	-	-	HBM>1,000V
FN32G	HBM>1,000V	-	-	-
QN32X	HBM>1,000V	-	-	-
EQ144G	HBM>1,000V	-	-	-
QN48X	HBM>1,000V	-	-	-

Table 4-7 GW1NR ESD - CDM

Device	GW1NR-1	GW1NR-2	GW1NR-4	GW1NR-9
QN88	-	-	CDM>500V	CDM>500V
MG49P/MG49G/MG49PG	-	HBM>1,000V		
MG81	-	-	CDM>500V	-
MG100P/MG100PF/MG100PA/ MG100PT/ MG100PS	-	-	-	CDM>500V
LQ100G	CDM>500V	-	-	-
LQ144	-	-	-	CDM>500V
QN32X	CDM>500V	-	-	-
FN32G	CDM>500V	-	-	-
EQ144G	CDM>500V	-	-	-
QN48X	CDM>500V			

4.3 DC Electrical Characteristics

4.3.1 DC Electrical Characteristics over Recommended Operating Conditions

Table 4-8 DC Electrical Characteristics over Recommended Operating Conditions

Name	Description	Condition	Min.	Typ.	Max.
I_{IL}, I_{IH}	Input or I/O leakage	$V_{CC0} < V_{IN} < V_{IH} (MAX)$	-	-	210 μA
		$0V < V_{IN} < V_{CC0}$	-	-	10 μA
I_{PU}	I/O Active Pull-up Current	$0 < V_{IN} < 0.7V_{CC0}$	-30 μA	-	-150 μA

Name	Description	Condition	Min.	Typ.	Max.
I _{PD}	I/O Active Pull-down Current	V _{IL} (MAX) < V _{IN} < V _{CCO}	30 μA	-	150 μA
I _{BHLS}	Bus Hold Low Sustaining Current	V _{IN} = V _{IL} (MAX)	30 μA	-	-
I _{BHHO}	Bus Hold High Sustaining Current	V _{IN} = 0.7V _{CCO}	-30 μA	-	-
I _{BHLO}	Bus Hold Low Overdrive Current	0 ≤ V _{IN} ≤ V _{CCO}	-	-	150 μA
I _{BHHO}	Bus Hold High Overdrive Current	0 ≤ V _{IN} ≤ V _{CCO}	-	-	-150 μA
V _{BHT}	Bus hold trip points		V _{IL} (MAX)	-	V _{IH} (MIN)
C1	I/O Capacitance			5 pF	8 pF
V _{HYST}	Hysteresis for Schmitt Trigge inputs	V _{CCO} = 3.3V, Hysteresis = Large	-	482mV	-
		V _{CCO} = 2.5V, Hysteresis = Large	-	302mV	-
		V _{CCO} = 1.8V, Hysteresis = Large	-	152mV	-
		V _{CCO} = 1.5V, Hysteresis = Large	-	94mV	-
		V _{CCO} = 3.3V, Hysteresis = Small	-	240mV	-
		V _{CCO} = 2.5V, Hysteresis = Small	-	150mV	-
		V _{CCO} = 1.8V, Hysteresis = Small	-	75mV	-
		V _{CCO} = 1.5V, Hysteresis = Small	-	47mV	-

4.3.2 Static Current

Table 4-9 Static Current

Device	Name	Description	LV/UV	Typ. (mA) ^[1]
GW1NR-1	I _{CC}	Core current (V _{CC} = 1.2V)	LV	1.8 ^[2]
	I _{CCO}	I/O Bank current (V _{CCO} = 2.5V)	LV	0.8
GW1NR-2	I _{CC}	Core current (V _{CC} = 1.2V)	LV/UV	1.5
	I _{CCX}	V _{CCX} current (V _{CCX} = 3.3V)	LV/UV	0.6
	I _{CCO}	I/O Bank current (V _{CCO} = 2.5V)	LV/UV	1
GW1NR-4	I _{CC}	Core current (V _{CC} = 1.2V)	LV/UV	2.8
	I _{CCX}	V _{CCX} current (V _{CCX} = 3.3V)	LV/UV	1.15
	I _{CCO}	I/O Bank current (V _{CCO} = 2.5V)	LV/UV	0.55
GW1NR-9	I _{CC}	Core current (V _{CC} = 1.2V)	LV/UV	3.5
	I _{CCX}	V _{CCX} current (V _{CCX} = 3.3V)	LV/UV	5
	I _{CCO}	I/O Bank current (V _{CCO} = 2.5V)	LV/UV	2

Note!

- [1] The Typ. value in Table 4-9 is the typical value of C6 device at 25°C.
- [2] For the GW1NR-1 device packaged with off-chip Flash, the I_{CC} is 2.8 mA.

4.3.3 Programming Current

Table 4-10 Programming Current

Device	Description	LV/UV	Max.(mA)
GW1NR-1	Core current when programming Flash ($V_{CC}=1.2V$)	LV	4.8
	I/O Bank current when programming Flash ($V_{CCO}=2.5V$)	LV	2.8
GW1NR-2	Core current when programming Flash ($V_{CC}=1.2V$)	LV	2.19
	V_{CCX} current when programming Flash ($V_{CCX}=3.3V$)	LV	12
	I/O Bank current when programming Flash ($V_{CCO}=2.5V$)	LV	2
GW1NR-4	Core current when programming Flash ($V_{CC}=1.2V$)	LV	2.19
	V_{CCX} current when programming Flash ($V_{CCX}=3.3V$)	LV	12
	I/O Bank current when programming Flash ($V_{CCO}=2.5V$)	LV	2
GW1NR-9	Core current when programming Flash ($V_{CC}=1.2V$)	LV	2.19
	V_{CCX} current when programming Flash ($V_{CCX}=3.3V$)	LV	12
	I/O Bank current when programming Flash ($V_{CCO}=2.5V$)	LV	2

Note!

- The current value in Table 4-10 is the max. programming current at room temperature under normal atmospheric pressure

4.3.4 I/O Operating Conditions Recommended

Table 4-11 I/O Operating Conditions Recommended

Name	Output V_{CCO} (V)			Input V_{REF} (V)		
	Min.	Typ.	Max.	Min.	Typ.	Max.
LVTTL33	3.135	3.3	3.465	-	-	-
LVC MOS33	3.135	3.3	3.465	-	-	-
LVC MOS25	2.375	2.5	2.625	-	-	-
LVC MOS18	1.71	1.8	1.89	-	-	-
LVC MOS15	1.425	1.5	1.575	-	-	-
LVC MOS12	1.14	1.2	1.26	-	-	-
SSTL15	1.425	1.5	1.575	0.68	0.75	0.9
SSTL18_I	1.71	1.8	1.89	0.833	0.9	0.969
SSTL18_II	1.71	1.8	1.89	0.833	0.9	0.969
SSTL25_I	2.375	2.5	2.645	1.15	1.25	1.35
SSTL25_II	2.375	2.5	2.645	1.15	1.25	1.35
SSTL33_I	3.135	3.3	3.465	1.3	1.5	1.7

Name	Output V _{CCO} (V)			Input V _{REF} (V)		
	Min.	Typ.	Max.	Min.	Typ.	Max.
SSTL33_II	3.135	3.3	3.465	1.3	1.5	1
HSTL18_I	1.71	1.8	1.89	0.816	0.9	1.08
HSTL18_II	1.71	1.8	1.89	0.816	0.9	1.08
HSTL15	1.425	1.5	1.575	0.68	0.75	0.9
PCI33	3.135	3.3	3.465	-	-	-
LVPECL33E	3.135	3.3	3.465	-	-	-
MLVDS25E	2.375	2.5	2.625	-	-	-
BLVDS25E	2.375	2.5	2.625	-	-	-
RSDS25E	2.375	2.5	2.625	-	-	-
LVDS25E	2.375	2.5	2.625	-	-	-
SSTL15D	1.425	1.5	1.575	-	-	-
SSTL18D_I	1.71	1.8	1.89	-	-	-
SSTL18D_II	1.71	1.8	1.89	-	-	-
SSTL25D_I	2.375	2.5	2.625	-	-	-
SSTL25D_II	2.375	2.5	2.625	-	-	-
SSTL33D_I	3.135	3.3	3.465	-	-	-
SSTL33D_II	3.135	3.3	3.465	-	-	-
HSTL15D	1.425	1.575	1.89	-	-	-
HSTL18D_I	1.71	1.8	1.89	-	-	-
HSTL18D_II	1.71	1.8	1.89	-	-	-

4.3.5 IOB Single - Ended DC Electrical Characteristic

Table 4-12 IOB Single - Ended DC Electrical Characteristic

Name	V _{IL}		V _{IH}		V _{OL} (Max)	V _{OH} (Min)	I _{OL} (mA)	I _{OH} (mA)
	Min	Max	Min	Max				
LVCMOS33 LVTTL33	-0.3V	0.8V	2.0V	3.6V	0.4V	V _{CCO} -0.4V	4	-4
							8	-8
							12	-12
							16	-16
							24	-24
					0.2V	V _{CCO} -0.2V	0.1	-0.1
LVCMOS25	-0.3V	0.7V	1.7V	3.6V	0.4V	V _{CCO} -0.4V	4	-4
							8	-8
							12	-12
							16	-16
LVCMOS18	-0.3V	0.35 x V _{CCO}	0.65 x V _{CCO}	3.6V	0.4V	V _{CCO} 0.4V	4	-4

Name	V_{IL}		V_{IH}		V_{OL} (Max)	V_{OH} (Min)	I_{OL} (mA)	I_{OH} (mA)
	Min	Max	Min	Max				
							8	-8
							12	-12
					0.2V	$V_{CCO}-0.2V$	0.1	-0.1
LVCMOS15	-0.3V	$0.35 \times V_{CCO}$	$0.65 \times V_{CCO}$	3.6V	0.4V	$V_{CCO}-0.4V$	4	-4
							8	-8
					0.2V	$V_{CCO}-0.2V$	0.1	-0.1
LVCMOS12	-0.3V	$0.35 \times V_{CCO}$	$0.65 \times V_{CCO}$	3.6V	0.4V	$V_{CCO}-0.4V$	2	-2
							6	-6
					0.2V	$V_{CCO}-0.2V$	0.1	-0.1
PCI33	-0.3V	$0.3 \times V_{CCO}$	$0.5 \times V_{CCO}$	3.6V	$0.1 \times V_{CCO}$	$0.9 \times V_{CCO}$	1.5	-0.5
SSTL33_I	-0.3V	$V_{REF}-0.2V$	$V_{REF}+0.2V$	3.6V	0.7	$V_{CCO}-1.1V$	8	-8
SSTL25_I	-0.3V	$V_{REF}-0.18V$	$V_{REF}+0.18V$	3.6V	0.54V	$V_{CCO}-0.62V$	8	-8
SSTL25_II	-0.3V	$V_{REF}-0.18V$	$V_{REF}+0.18V$	3.6V	NA	NA	NA	NA
SSTL18_II	-0.3V	$V_{REF}-0.125V$	$V_{REF}+0.125V$	3.6V	NA	NA	NA	NA
SSTL18_I	-0.3V	$V_{REF}-0.125V$	$V_{REF}+0.125V$	3.6V	0.40V	$V_{CCO}-0.40V$	8	-8
SSTL15	-0.3V	$V_{REF}-0.1V$	$V_{REF}+0.1V$	3.6V	0.40V	$V_{CCO}-0.40V$	8	-8
HSTL18_I	-0.3V	$V_{REF}-0.1V$	$V_{REF}+0.1V$	3.6V	0.40V	$V_{CCO}-0.40V$	8	-8
HSTL18_II	-0.3V	$V_{REF}-0.1V$	$V_{REF}+0.1V$	3.6V	NA	NA	NA	NA
HSTL15_I	-0.3V	$V_{REF}-0.1V$	$V_{REF}+0.1V$	3.6V	0.40V	$V_{CCO}-0.40V$	8	-8
HSTL15_II	-0.3V	$V_{REF}-0.1V$	$V_{REF}+0.1V$	3.6V	NA	NA	NA	NA

4.3.6 IOB Differential Electrical Characteristics

Table 4-13 IOB Differential Electrical Characteristics

Name	Description	Condition	Min.	Typ.	Max.	Unit
V_{INA}, V_{INB}	Input Voltage		0	-	2.15	V
V_{CM}	Input Common Mode Voltage	Half the Sum of the Two Inputs	0.05	-	2.1	V
V_{THD}	Differential Input Threshold	Difference Between the Two Inputs	± 100	-	-	mV
I_{IN}	Input Current	Power On or Power Off	-	-	± 20	μA
V_{OH}	Output High Voltage for V_{OP} or V_{OM}	$R_T = 100\Omega$	-	-	1.60	V
V_{OL}	Output Low Voltage for V_{OP} or V_{OM}	$R_T = 100\Omega$	0.9	-	-	V
V_{OD}	Output Voltage Differential	$(V_{OP} - V_{OM}), R_T = 100\Omega$	250	350	450	mV
ΔV_{OD}	Change in V_{OD} Between High		-	-	50	mV

Name	Description	Condition	Min.	Typ.	Max.	Unit
	and Low					
V _{OS}	Output Voltage Offset	(V _{OP} + V _{OM})/2, R _T = 100Ω	1.125	1.20	1.375	V
ΔV _{OS}	Change in V _{OS} Between High and Low		-	-	50	mV
I _S	Short-circuit current	V _{OD} = 0V output short-circuit	-	-	15	mA

4.4 Switching Characteristics

4.4.1 Internal Switching Characteristics

Table 4-14 CFU Block Internal Timing Parameters

Name	Description	Speed Grade		Unit
		Min	Max	
t _{LUT4_CFU}	LUT4 delay	-	0.674	ns
t _{LUT5_CFU}	LUT5 delay	-	1.388	ns
t _{LUT6_CFU}	LUT6 delay	-	2.01	ns
t _{LUT7_CFU}	LUT7 delay	-	2.632	ns
t _{LUT8_CFU}	LUT8 delay	-	3.254	ns
t _{SR_CFU}	Set/Reset to Register output	-	1.86	ns
t _{CO_CFU}	Clock to Register output	-	0.76	ns

4.4.2 BSRAM Internal Timing Parameters

Table 4-15 BSRAM Internal Timing Parameters

Name	Description	Speed Grade		Unit
		Min	Max	
t _{COAD_BSRAM}	Clock to output from read address/data	-	5.10	ns
t _{COOR_BSRAM}	Clock to output from output register	-	0.56	ns

4.4.3 DSP Internal Timing Parameters

Table 4-16 DSP Internal Timing Parameters

Name	Description	Speed Grade		Unit
		Min	Max	
t _{COIR_DSP}	Clock to output from input register	-	4.80	ns
t _{COPR_DSP}	Clock to output from pipeline register	-	2.40	ns
t _{COOR_DSP}	Clock to output from output register	-	0.84	ns

4.4.4 Gearbox Switching Characteristics

Table 4-17 Gearbox Internal Timing Parameters

Device	Name	Description	Min.	Unit
GW1NR-1/4	FMAX _{IDDR}	2:1 Gearbox maximum input serial rate	600	Mbps
	FMAX _{IDES4}	4:1 Gearbox maximum input serial rate	800	Mbps
	FMAX _{IDESx}	8:1/10:1 Gearbox maximum input serial rate	1000	Mbps
	FMAX _{ODDR}	1:2 Gearbox maximum input serial rate	600	Mbps
	FMAX _{OSER4}	1:4 Gearbox maximum output serial rate	800	Mbps
	FMAX _{OSERx}	1:8/1:10 Gearbox maximum output serial rate	1000	Mbps
GW1NR-9	FMAX _{IDDR}	2:1 Gearbox maximum input serial rate	600	Mbps
	FMAX _{IDES4}	4:1 Gearbox maximum input serial rate	800	Mbps
	FMAX _{IDESx}	8:1/10:1/16:1 Gearbox maximum input serial rate	1200	Mbps
	FMAX _{ODDR}	1:2 Gearbox maximum output serial rate	600	Mbps
	FMAX _{OSER4}	1:4 Gearbox maximum output serial rate	800	Mbps
	FMAX _{OSERx}	1:8/1:10/1:16 Gearbox maximum output serial rate	1200	Mbps

Note!

- LVDS IO speed can be up to 1Gbps, but note that for 1:4 Gearbox and 1:2 Gearbox, the internal core may not reach the corresponding speed.
- Driver=3.5 mA.

Table 4-18 Single-ended IO Fmax

Name	Fmax	
	Min. Value(Mhz)	
	DriverStrength = 4mA	DriverStrength > 4mA
LVTTL33	150	300
LVC MOS33	150	300
LVC MOS25	150	300
LVC MOS18	150	300
LVC MOS15	150	200
LVC MOS12	150	150

Note!

- The test loading is 30pF capacitor.

4.4.5 External Switching Characteristics

Table 4-19 External Switching Characteristics

Name	-4		-5		-6	
	Min	Max	Min	Max	Min	Max
HCLK Tree delay	0.8	1.4	0.5	1.2	ns	TBD
PCLK Tree delay(GCLK0~5)	1.4	2.6	1.0	2.2	ns	TBD
PCLK Tree delay(GCLK6~7)	1.8	3.2	1.4	2.9	ns	TBD
Pin-LUT-Pin Delay	3.4	5	3	4.5	ns	TBD

4.4.6 On chip Oscillator Output Frequency

Table 4-20 On chip Oscillator Output Frequency

Name	Description	Min.	Typ.	Max.	
f_{MAX}	On chip Oscillator Output Frequency (0 ~ +85°C)	GW1NR-4	99.75MHz	105MHz	110.25MHz
		GW1NR-1/2/9	118.75MHz	125MHz	131.25MHz
	On chip Oscillator Output Frequency (-40 ~ +100°C)	GW1NR-4	94.5MHz	105MHz	115.5MHz
		GW1NR-1/2/9	112.5MHz	125MHz	137.5MHz
t_{DT}	Clock Duty Cycle	43%	50%	57%	
t_{OPJIT}	Clock Period Jitter	0.01 UIPP	0.012 UIPP	0.02 UIPP	

4.4.7 PLL Switching Characteristics

Table 4-21 PLL Switching Characteristics

Device	Speed	Name	Min.	Max.
GW1NR-4	C6/15 A4	CLKIN	3MHZ	400MHZ
		PFD	3MHZ	400MHZ
		VCO	400MHZ	1000MHZ
		CLKOUT	3.125MHZ	500MHZ
	C5/14	CLKIN	3MHZ	320MHZ
		PFD	3MHZ	320MHZ
		VCO	320MHZ	800MHZ
		CLKOUT	2.5MHZ	400MHZ
GW1NR-9	C7/16 C6/15	CLKIN	3MHZ	400MHZ
		PFD	3MHZ	400MHZ
		VCO	400MHZ	1200MHZ
		CLKOUT	3.125MHZ	600MHZ
	C5/14	CLKIN	3MHZ	320MHZ

Device	Speed	Name	Min.	Max.
		PFD	3MHZ	320MHZ
		VCO	320MHZ	960MHZ
		CLKOUT	2.5MHZ	480MHZ
GW1NR-1	C6/15	CLKIN	3MHZ	400MHZ
		PFD	3MHZ	400MHZ
		VCO	400MHZ	900MHZ
		CLKOUT	3.125MHZ	450MHZ
	C5/14	CLKIN	3MHZ	320MHZ
		PFD	3MHZ	320MHZ
		VCO	320MHZ	720MHZ
CLKOUT		2.5MHZ	360MHZ	
GW1NR-2	C7/16 C6/15	CLKIN	3MHZ	400MHZ
		PFD	3MHZ	400MHZ
		VCO	400MHZ	800MHZ
		CLKOUT	3.125MHZ ^[1]	750MHZ
	C5/14	CLKIN	3MHZ	320MHZ
		PFD	3MHZ	320MHZ
		VCO	320MHZ	640MHZ
		CLKOUT	2.5MHZ	640MHZ

Note!

- [1] The min. output frequency for different channels may be different. The min. output frequency for channel A is VCO/128, which is 3.125MHZ/2.5MHZ; Channel B/C/D needs to be judged according to whether it is cascaded (parameter). If it is not cascaded, it is the same as channel A; if it is cascaded, it needs to be divided by 128 again.

4.5 User Flash Characteristics

4.5.1 DC Characteristics¹

($T_J = -40\sim+100^\circ\text{C}$, $V_{CC} = 1.08\sim 1.32\text{V}$, $V_{CCX} = 1.62\sim 3.63\text{V}$, $V_{SS} = 0\text{V}$)

Table 4-22 User Flash DC Characteristics

Name	Parameter	Max.		Unit	Wake-up Time	Condition
		V_{CC}^3	V_{CCX}			
Read mode (w/I 25ns) ¹	I_{CC1}^2	2.19	0.5	mA	NA	Min. Clcok period, duty cycle 100%, VIN = "1/0"
Write mode		0.1	12	mA	NA	
Erase mode		0.1	12	mA	NA	
Page Erasure Mode		0.1	12	mA	NA	
Read mode static current (25-50ns)	I_{CC2}	980	25	μA	NA	XE=YE=SE="1", between $T=T_{acc}$ and $T=50\text{ns}$, I/O=0mA; later than $T=50\text{ns}$, read mode is turned off, and I/O current is the current of standby mode.
Standby mode	I_{SB}	5.2	20	μA	0	V_{SS} , V_{CCX} , and V_{CC}

Note!

- [1] Means the average current, and the peak value is higher than the average one.
- [2] Calculated in different T_{new} clock periods.
 - $T_{new} < T_{acc}$ is not allowed
 - $T_{new} = T_{acc}$
 - $T_{acc} < T_{new} - 50\text{ns}$: $I_{CC1}(\text{new}) = (I_{CC1} - I_{CC2})(T_{acc}/T_{new}) + I_{CC2}$
 - $T_{new} > 50\text{ns}$: $I_{CC1}(\text{new}) = (I_{CC1} - I_{CC2})(T_{acc}/T_{new}) + 50\text{ns} \times I_{CC2}/T_{new} + I_{SB}$
 - $t > 50\text{ns}$, $I_{CC2} = I_{SB}$
- [3] V_{CC} must be greater than 1.08V from the zero wake-up time.

4.5.2 Timing Parameters^{1,5,6}

($T_J = -40\sim+100^\circ\text{C}$, $V_{CC} = 0.95\sim 1.05\text{V}$, $V_{CCX} = 1.7\sim 3.45\text{V}$, $V_{SS} = 0\text{V}$)

Table 4-23 User Flash Timing Parameters

User Modes	Parameter	Name	Min.	Max.	Unit
Access time ²	WC1	T_{acc}^3	-	25	ns
	TC		-	22	ns
	BC		-	21	ns
	LT		-	21	ns
	WC		-	25	ns
Program/Erase to data storage		T_{nvs}	5	-	μs
Data storage hold time		T_{nvh}	5	-	μs

User Modes	Parameter	Name	Min.	Max.	Unit
	Data storage hold time (Overall erase)	T_{nvh1}	100	-	μ s
	Time from data storage to program setup	T_{pgs}	10	-	μ s
	Program hold time	T_{pgh}	20	-	ns
	Write time	T_{prog}	8	16	μ s
	Write ready time	T_{wpr}	>0	-	ns
	Erase hold time	T_{whd}	>0	-	ns
	Time from control signal to write/Erase setup	T_{cps}	-10	-	ns
	Time from SE to read setup	T_{as}	0.1	-	ns
	E pulse high level time	T_{pws}	5	-	ns
	Address/data setup time	T_{ads}	20	-	ns
	Address/data hold time	T_{adh}	20	-	ns
	Data hold-up time	T_{dh}	0.5	-	ns
Read mode address hold time ³	WC1	T_{ah}	25	-	ns
	TC		22	-	ns
	BC		21	-	ns
	LT		21	-	ns
	WC		25	-	ns
	SE pulse low level time	T_{nws}	2	-	ns
	Recovery time	T_{rcv}	10	-	μ s
	Data storage time	T_{nv}^4	-	6	ms
	Erasure time	T_{erase}	100	120	ms
	Overall erase time	T_{me}	100	120	ms
	Wake-up time from power down to standby mode	T_{wk_pd}	7	-	μ s
	Standby hold time	T_{sbh}	100	-	ns
	V_{CC} setup time	T_{ps}	0	-	ns
	V_{CCX} hold time	T_{ph}	0	-	ns

Note!

- [1] The parameter values may change;
- [2] The values are simulation data only.
- [3]After XADR, YADR, XE, and YE are valid, T_{acc} start time is SE rising edge. DOUT is kept until the next valid read operation;
- [4] T_{nv} is the time between write and the next erasure. The same address can not be written twice before erasure, so does the same register. This limitation is for safety;
- [5]Both the rising edge time and falling edge time for all waveform is 1ns;
- [6] TX, YADR, XE, and YE hold time need to be T_{acc} at leaset, and T_{acc} start from SE rising edge.

4.5.3 Operation Timing Diagrams

Figure 4-1 GW1NR User Flash Read Operation

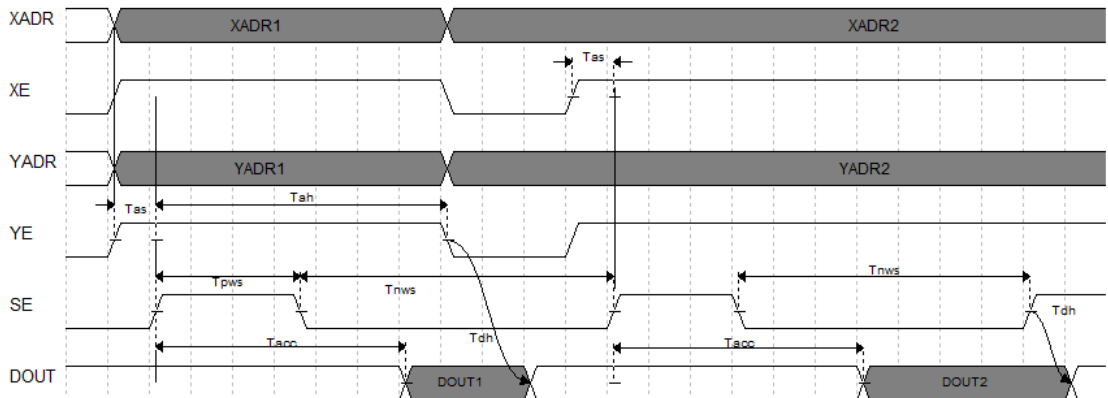

Figure 4-2 GW1NR User Flash Program Operation

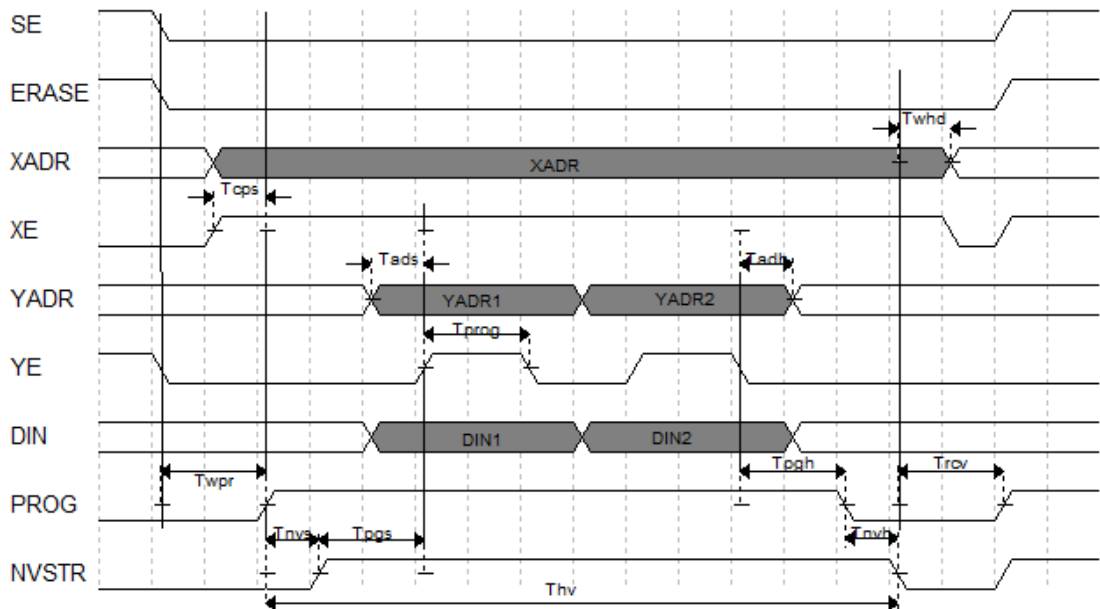
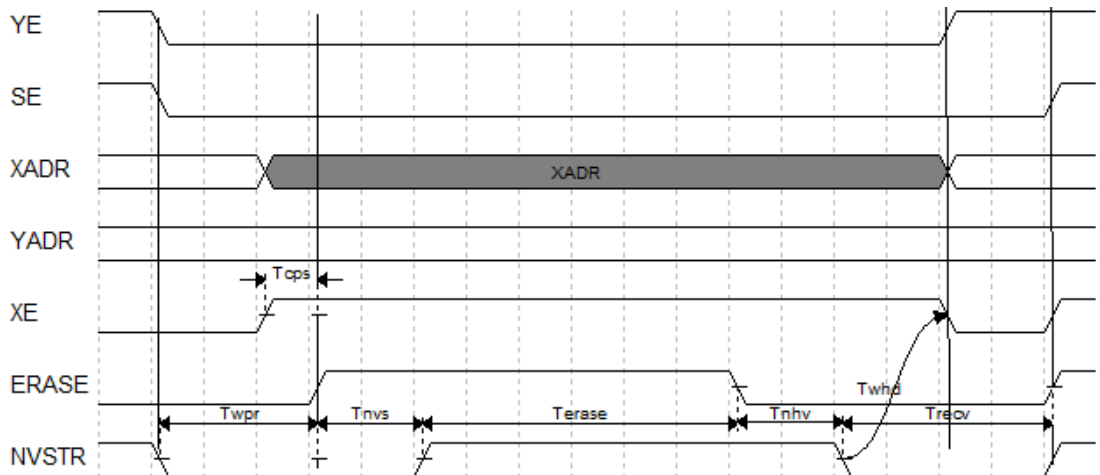

Figure 4-3 GW1NR User Flash Erase Operation



4.6 Configuration Interface Timing Specification

The GW1NR series of FPGA products GowinCONFIG support six configuration modes: AUTO BOOT, SSPI, MSPI, DUAL BOOT, SERIAL, and CPU. For more detailed information, please refer to *UG290, Gowin FPGA Products Programming and Configuration User Guide*.

5 Ordering Information

5.1 Part Name

Part naming description is as shown in Figure 5-1 and Figure 5-2.

Note!

- For further pin number and package type information, please refer to 2.2 Product Resources and 2.3 Package Information.
- The LittleBee® family devices and Arora family devices of the same speed level have different speed.
- Both “C” and “I” are used in GOWIN part name marking for one same device, such as C6/I5, C7/I6, etc. GOWIN devices are screened using industrial standards, so one same device can be used for both industrial (I) and commercial (C) applications. The maximum temperature of the industrial grade is 100°C, and the maximum temperature of the commercial grade is 85°C. Therefore, if the same chip meets the speed level 7 in the commercial grade application, the speed level is 6 in the industrial grade application.

Figure 5-1 Part Naming-ES

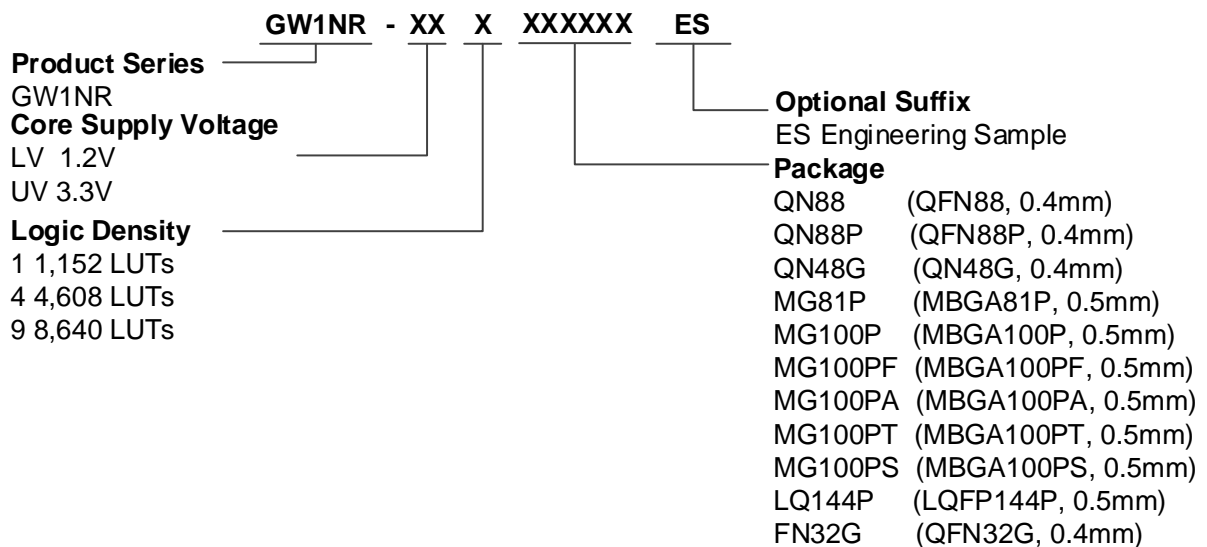
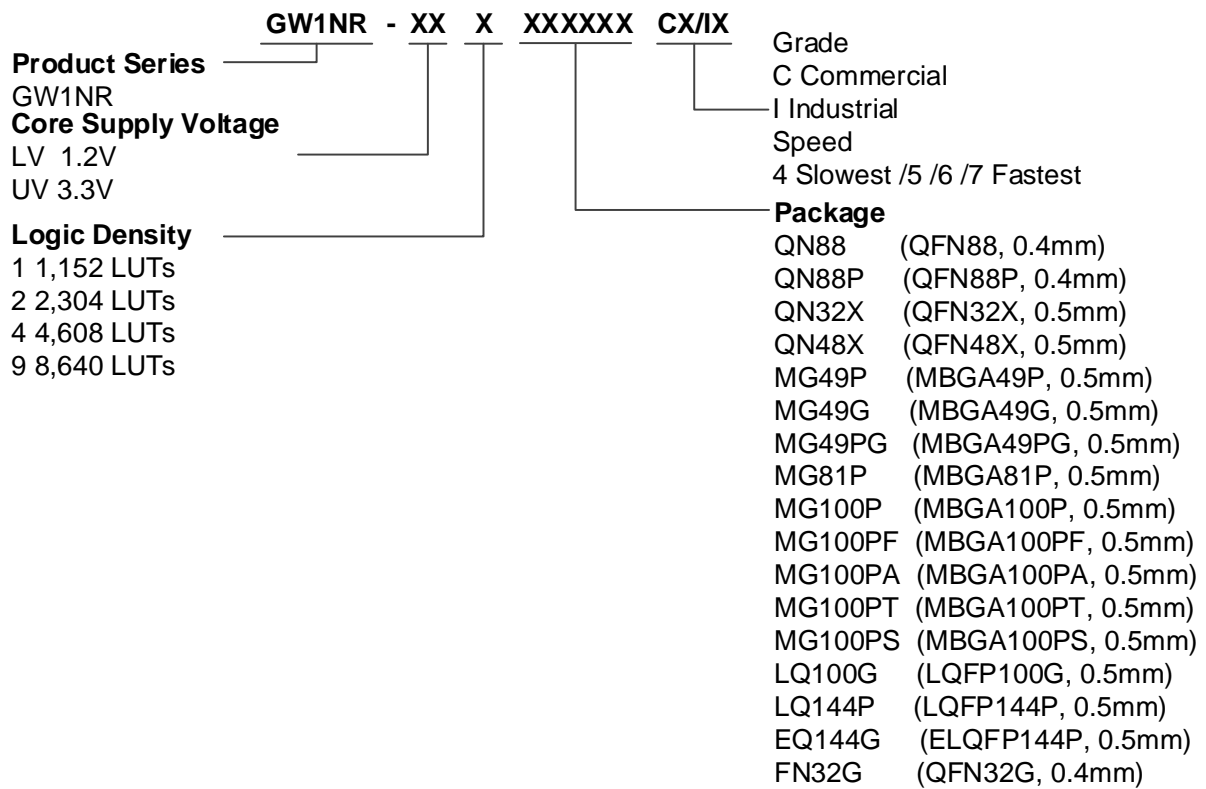

Figure 5-2 Part Naming-Production



5.2 Package Mark Example

The device information of GOWINSEMI is marked on the chip surface, as shown in Figure 5-3.

Figure 5-3 Package Mark Example

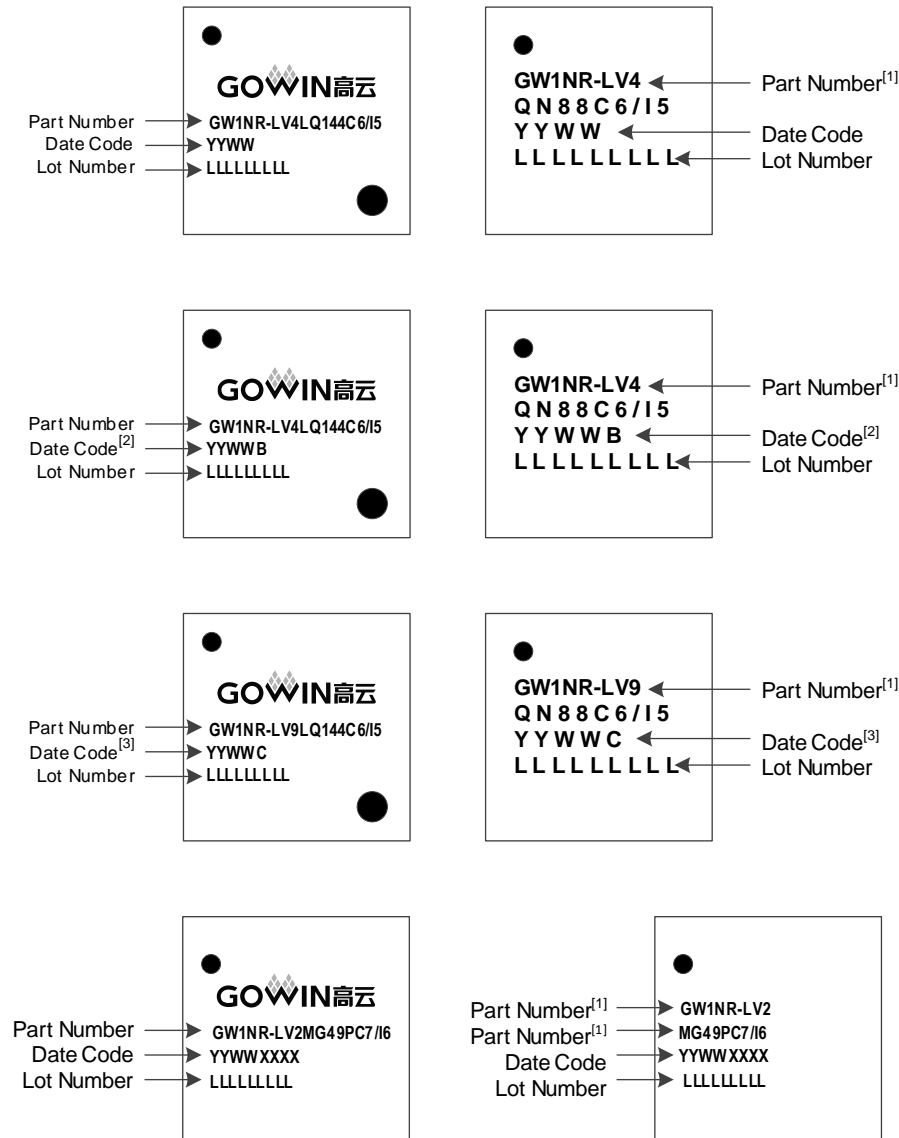

Note!

- [1] The first two lines in the right figure above are the "Part Number".
- [2] The Data Code followed by a "B" is for B version devices.
- [3] The Data Code followed by a "C" is for C version devices.



X-ON Electronics

Largest Supplier of Electrical and Electronic Components

Click to view similar products for [FPGA - Field Programmable Gate Array](#) category:

Click to view products by [GOWIN](#) manufacturer:

Other Similar products are found below :

[EP1S10F672C7](#) [EP1S20F672I7N](#) [EP1SGX25DF672I6N](#) [PLUS16L87N](#) [PLUS16R67N](#) [PLUS20L87N](#) [PLUS20R87N](#) [5AGXBA5D6F27C6N](#)
[EP1S20F672C7N](#) [EP1SGX25DF672I6](#) [EP20K300EFI672-2X](#) [EP2C35F672I8](#) [EP2S15F672C3N](#) [LFE2-35E-6FN484I](#) [EPF10K200SFI672-2B](#)
[M2S060TS-1FG484M](#) [M2GL010-VFG256I](#) [EP1S10F672C7N](#) [LFXP2-40E-5FN484IAFI](#) [M2GL005-VF256I](#) [LCMXO3D-9400HC-6BG400C](#)
[LCMXO3D-9400HC-5BG400I](#) [LCMXO3D-9400HC-6BG400I](#) [LCMXO3D-9400ZC-3BG400I](#) [LCMXO3D-9400ZC-2BG400C](#) [LCMXO3D-](#)
[9400HC-6BG484C](#) [LCMXO3D-9400HC-6BG484I](#) [LCMXO3D-9400HC-5BG484I](#) [GW1N-LV4CS72C6/I5](#) [GW1NR-UV4MG81PC6/I5](#)
[GW1N-LV9UG332C6/I5](#) [GW1NR-LV4MG81PC6/I5](#) [GW1NZ-LV1CS16C6/I5](#) [GW1NR-LV9QN88PC6/I5](#) [GW1N-LV4MG160C6/I5](#)
[GW1NR-UV4QN88C6/I5](#) [GW1NR-UV9QN88PC6/I5](#) [GW1NR-LV9LQ144PC6/I5](#) [LIFCL-17-7SG72C](#) [LIFCL-40-7MG289I](#) [GW1N-](#)
[UV9MG160C6/I5](#) [LIF-MDF6000-6KMG80I](#) [EP2AGX45CU17I5G](#) [M2GL050-FGG484](#) [ICE40LP1K-CB121](#) [ICE40UL1K-CM36A1TR1K](#)
[LCMXO3L-4300C-5BG324C](#) [LCMXO3LF-6900C-5BG324C](#) [LFE2-6E-6FN256I](#) [LFE2M20SE-5F256C](#)