

SERIES 68P

Long Life Potentiometer Substitute

FEATURES

- Ratiometric analog output
- Debris resistant Hall effect sensor technology
- 7 million rotational cycles
- Single or redundant output
- Custom output options
- Optional shaft and panel seal
- Reverse voltage and overvoltage protection

APPLICATIONS

- Test & Measurement equipment
- Audio / Visual equipment
- Potentiometer substitute with long life
- Agriculture & Construction engine speed control

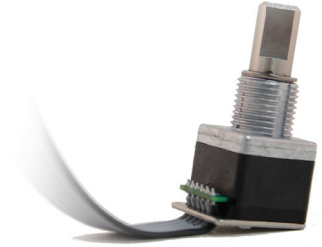

DIMENSIONS in inches [millimeters]

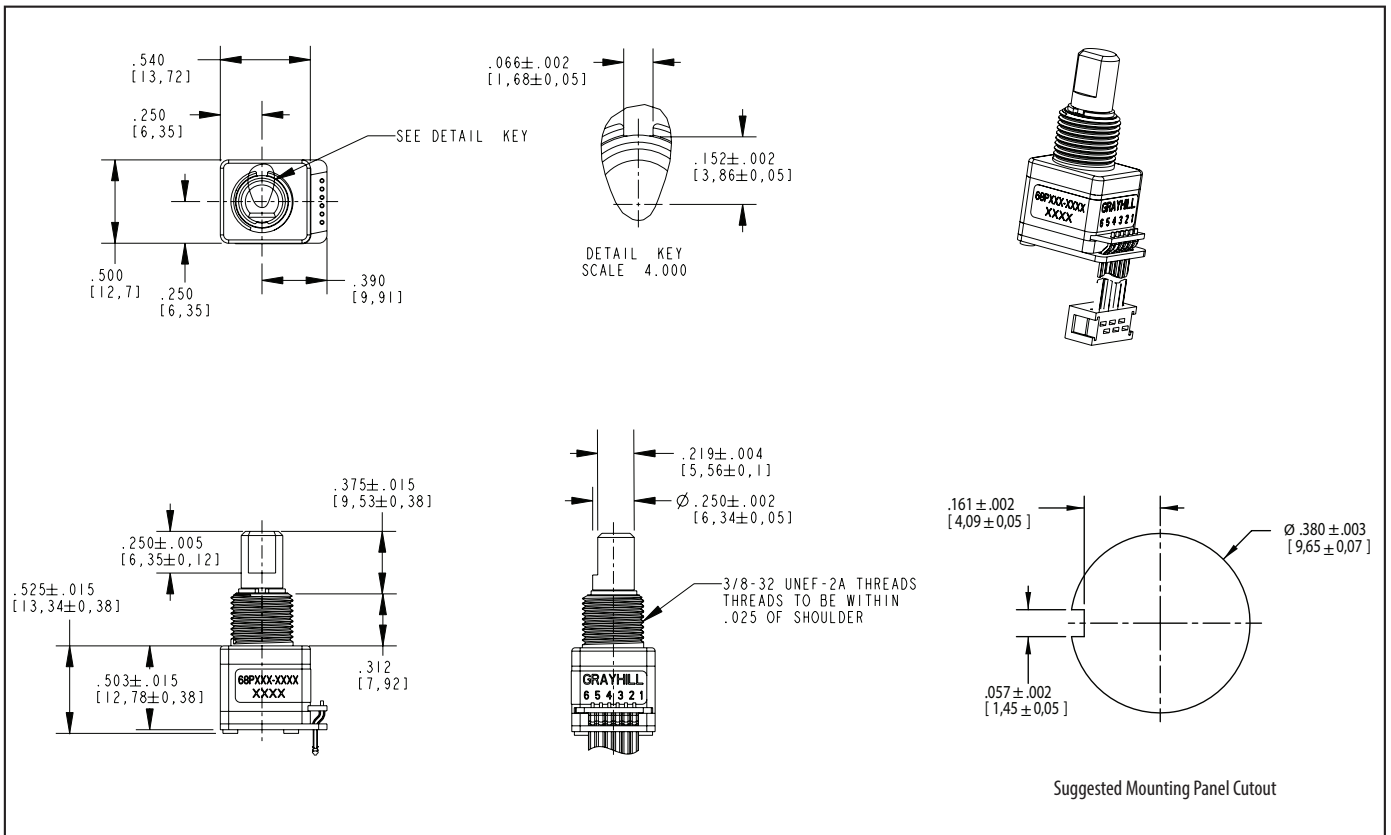

TERMINATION OPTIONS

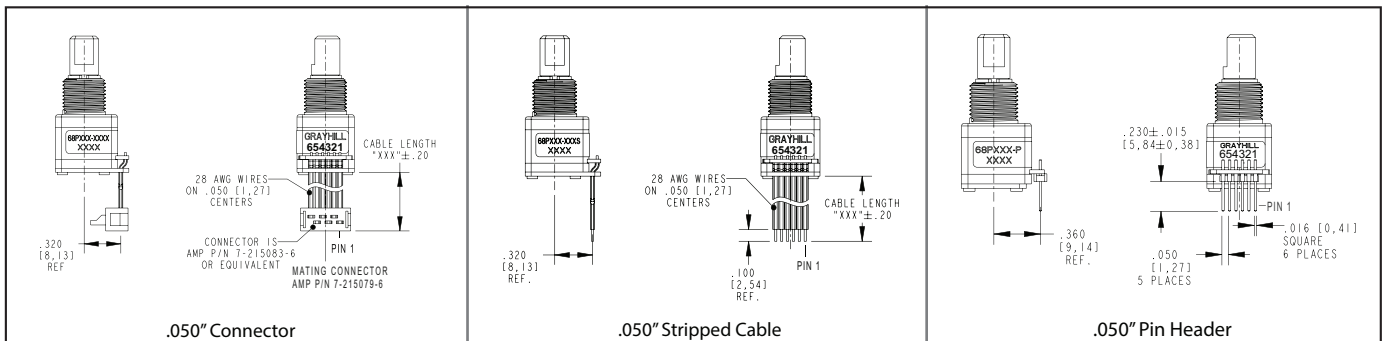

ELECTRICAL SCHEMATIC

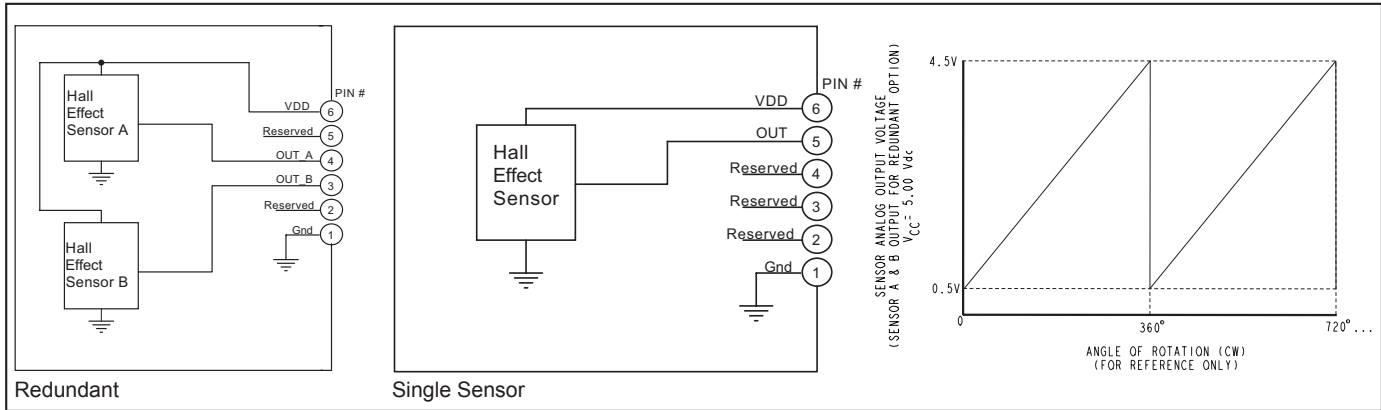

* Customized electrical outputs are available. Contact Grayhill for additional details.

SPECIFICATIONS

Electrical Ratings

Operating Voltage: Minimum 4.5V, maximum 5.5V (VDD)

Absolute Maximum Voltage* on Pin 6 (VDD): -18V to +27V

Supply Current Redundant Sensors: Typical 22mA, maximum 40mA

Supply Current Single Sensor: Typical 11mA, maximum 20mA

Output Current: 2.5mA max

Recommended Load: 2K-5.6K Ohms Pull-Down Resistor

Power-Up Time: 20ms

Sensor Error: When an internal sensor error occurs, the output goes to $\leq 4\%$ of supply (VDD)

Solderability: 95% free of pin holes & voids, MIL-STD-202, Method 208

Environmental Ratings

Operating Temperature: -40°C to 85°C, IEC 68-2-1, Test Aa and IEC 68-2-2, Test Aa

Storage Temperature: -55°C to 85°C, IEC 68-2-1, Method Aa and IEC 68-2-2, Method Ba

Humidity: 96 hours @ 90-95% humidity @ 40°C, MIL-STD-202, Method 103B

Mechanical Vibration: Harmonic motion with amplitude of 15g within a varied frequency of 10 to 2000 Hz for 12 hours, MIL-STD-202, Method 204, Test Condition B

Mechanical Shock:

Test 1: 100g for 6 ms half-sine wave with a velocity change of 12.3 ft/s.

Test 2: 100g for 6 ms sawtooth wave with a velocity change of 9.7 ft/s, MIL-STD-202, Method 213, Test Condition C and I

Thermal Shock: 25 cycles from -55°C to 100°C, MIL-STD-810F, Method 503.4, procedure I

Seal: IP67, Meets IEC 60529

Cable: Copper stranded with topcoat in PVC, 28 AWG (cable version only)

Header Pins: Tin-plated phosphor bronze

ROHS Compliant

EMC Ratings

Radiated Immunity: Meets ANSI/ASAE EP455 5.16 (100 V/m, 0.014-1000 MHz, 3 orientations)

Conducted Immunity: Meets IEC 61000-4-6, Level 3

Radiated Emissions: Meets ISO 14982, Sec 6.4 (Broadband), Sec 6.5 (Narrowband) limits

Conducted Emissions: Meets CISPR 25, Class 3

Electrostatic Discharge: Meets ANSI/ASAE EP455 5.12, Level 1

Power Frequency Magnetic Field: Meets IEC 61000-4-8, 100 V/m

* Exceeding the Absolute Maximum Voltage may result in permanent damage to the device. This is a stress rating only and functional operation of the device at those or any other conditions above those indicated in the operation listings of this specification is not implied.

Soldering Recommendation

Hand solder only per IPC J-STD-001

Physical & Mechanical Ratings

Life: 7,000,000 cycles of operation. 1 cycle is a rotation through all positions and a full return

Average Rotational Torque: 1.5 in-oz maximum

Maximum rotational speed: 100 rpm

Mounting Torque: 15 in-lbs. maximum

Shaft Pushout / Pullout Force: 45 lbs. / 45 lbs. minimum

Terminal Strength: 15 lbs. minimum. Cable or Header pullout force, MIL-STD-202, Method 211A, Test Condition A

Materials and Finishes

Bushing: Zinc

Shaft: Stainless Steel

Hex Nut: Nickel plated brass

Lockwasher: Spring steel, zinc plate with clear trivalent chromate finish

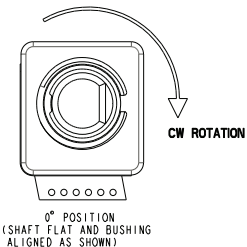

Encoder has ratiometric analog output (output levels are proportional to the supply voltage). Specifications on this datasheet apply @ VDD = 5.00 V.

ORDERING INFORMATION

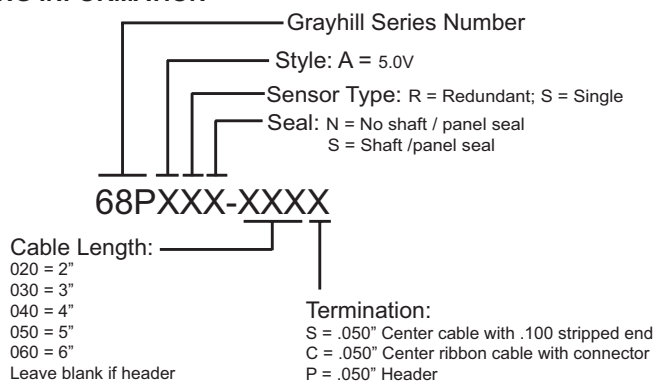

MOUNTING PANEL RECOMMENDATIONS FOR PANEL SEAL VERSION:

1. Panel thickness should not exceed 0.157".
2. Mounting hole diameter to be per recommended dimensions.
3. 0.470" X 0.020" counter bore required for proper sealing.
4. Anti-rotation feature is recommended. Feature should be designed to lock into bushing keyway.

For prices and custom configurations, contact a local sales office, an authorized distributor, or Grayhill's sales department.

X-ON Electronics

Largest Supplier of Electrical and Electronic Components

Click to view similar products for [Board Mount Hall Effect/Magnetic Sensors](#) category:

Click to view products by [Grayhill](#) manufacturer:

Other Similar products are found below :

[HGPRDT005A](#) [AH277AZ4-AG1](#) [AV-10379](#) [AV-10448](#) [SS41C](#) [AH1894-Z-7](#) [ATS601LSGTN-LT-WU4-T](#) [TLE4917](#) [50017859-003](#) [TY-13101](#) [TLE4976L](#) [AH49FNTR-G1](#) [SS85CA](#) [AH277AZ4-BG1](#) [TLE49614MXTSA1](#) [AH3377-P-B](#) [AH211Z4-AG1](#) [AH3360-FT4-7](#) [SS460S-100SAMPLE](#) [50065820-03](#) [TLE4941PLUSCB](#) [AH374-P-A](#) [AH1806-P-A](#) [AH374-W-7](#) [SS460P-T2](#) [AH1913-W-7](#) [SS413F](#)
[TLE5046ICAKLRHALA1](#) [TLE49421CHAMA2](#) [TLE4941PLUSCXAMA1](#) [AH1912-W-EVM](#) [AH1903-FA-EVM](#) [AH3774-W-EVM](#)
[AH49FNTR-EVM](#) [MMC5633NJL](#) [AH3360-FA-EVM](#) [AH8502-FDC-EVM](#) [AH3366Q-SA-EVM](#) [AH3774-P-EVM](#) [KTH1601SU-ST3](#)
[MG910](#) [MG910M](#) [MG911](#) [MG610](#) [MW921](#) [MW922](#) [TLE4998S3XALA1](#) [TLE5011FUMA1](#) [TLE5027CE6747HAMA1](#)
[TLE5109A16E2210XUMA1](#)