

Ordering and Marking Information

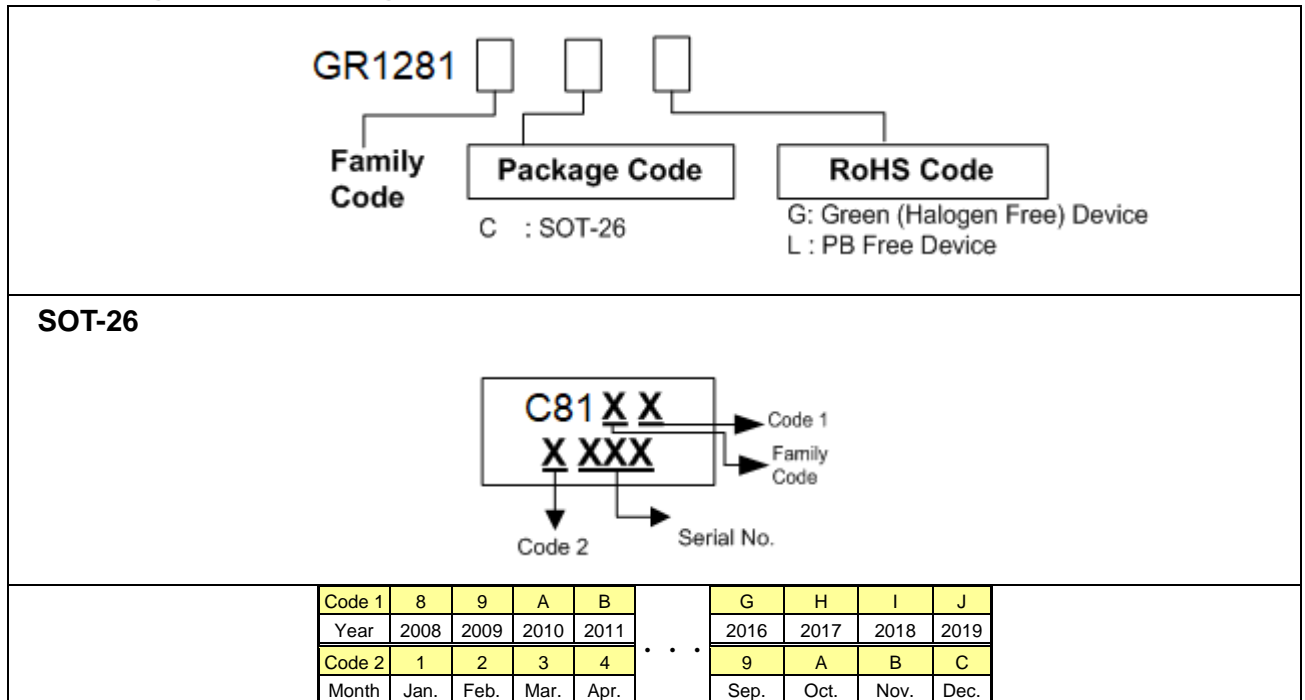

Nanjing Greenchip Semiconductor Co., Ltd.(Grenergy OPTO Inc.) reserves the right to make changes to improve reliability or manufacture ability without notice, and advise customers to obtain the latest version of relevant information to verify before placing orders.

Pin Configuration

SOT-26 (TOP VIEW)

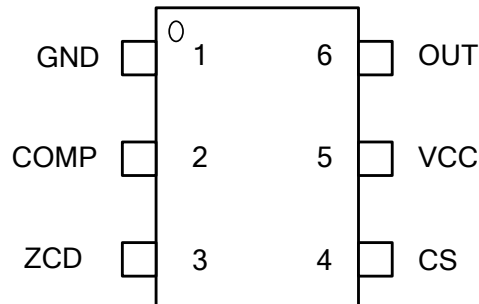

Pin Description

Pin No.	Name	Function
1	GND	Ground reference pin
2	COMP	Voltage feedback pin, by connecting a photo-coupler to control the duty cycle
3	ZCD	This pin is function of Brown in/out and OVP
4	CS	Current sense pin, connected to sense resistor for sensing the MOSFET current signal
5	VCC	Power supply pin
6	OUT	he output driver for driving the external MOSFET

Absolute Maximum Ratings

Supply voltage VCC	-----	30V
COMP, CS, ZCD	-----	-0.3~6.0V
OUT	-----	-0.3~Vcc+0.3V
Junction temperature	-----	150°C
Storage temperature range	-----	-65°C ~ 150 °C
SOT-26 package thermal resistance	-----	250°C/W
Power dissipation (SOT-26, at ambient temperature = 85°C)	-----	250mW
Lead temperature (SOT-26,soldering, 10 sec)	-----	230°C
Lead temperature (All Pb free packages, soldering, 10 sec)	-----	260°C
ESD, human body model	-----	2.5KV
ESD, machine model	-----	250V

Caution: The “Absolute Maximum Ratings” are those values beyond which the safety of the device cannot be guaranteed and may cause permanent damage to the IC. These are stress ratings only and functional operation of the device at these or any other condition beyond those indicated in the Electrical Characteristics section of the specification is not implied. The “Electrical Characteristics” table defines the conditions for actual device operation. Exposure to absolute maximum rated conditions for extended periods may affect device reliability.

Recommended Operating Conditions

Item	Min.	Max.	Unit
Operating Junction temperature	-40	125	°C
Operating ambient temperature	-40	85	°C
Start Up Resistor (AC Half side)	540k	2.2M	Ω
Supply voltage VCC	9.5	26.5	V
VCC Capacitor	2.2	10	μF
COMP pin paralleling capacitor	1	33	nF
CS pin paralleling capacitor	100	1000	pF

Note:

- Not to exceed the maximum junction temperature of the IC, this relates to the operating power of the IC and the thermal resistance of the IC-package as above.
- The small signal components should be placed to IC pin as possible.
- A chemical capacitor and 1206 SMD ceramic capacitor are recommend for VCC to avoid noise of Resonance
- It's essential to connect VCC pin with a SMD ceramic capacitor (0.1μF~0.47μF) to filter out the undesired switching noise for stable operation.
- Connecting a capacitor to COMP pin is also essential to filter out the undesired switching noise for stable operation.

Block Diagram

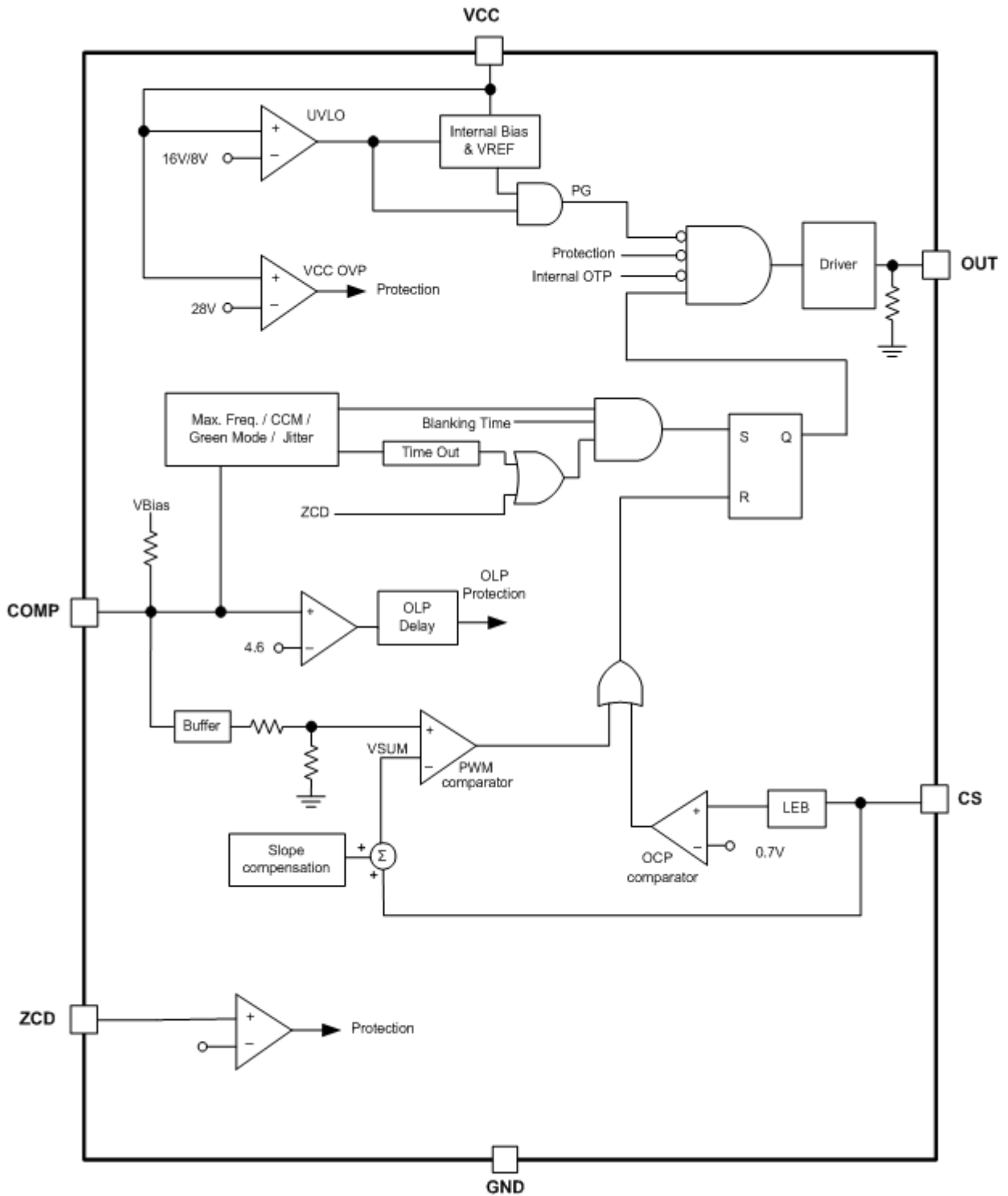

Electrical Characteristics (TA = +25°C unless otherwise stated, VCC = 15.0V)

Parameter	Min.	Typ.	Max.	Unit
SUPPLY VOLTAGE (VCC Pin)				
Startup current VCC=UVLO ON-0.1V		2	5	uA
Operating current(with 1nF load on OUT pin), Vcomp = 0V	0.35	0.55	0.75	mA
Operating current(with 1nF load on OUT pin), Vcomp = 2.5V		2	2.8	mA
Operating current (with 1nF load on OUT pin), protection tripped (VCC OVP, OLP, ZCD OVP/UVP)	0.8	1	1.2	mA
UVLO-OFF	7	8	9	V
UVLO-ON	15	16.0	17	V
VCC Mode Entry Point		8.5		V
Hysteresis		0.5		V
OVP level on VCC pin	26.5	28	29.5	V
OVP level on VCC pin Debounce Time*		100		μS
VOLTAGE FEEDBACK (COMP Pin)				
Short circuit current, Vcomp = 0V	150	200	250	uA
Open loop voltage, COMP pin open	4.9	5.3	5.7	V
Green Mode Start voltage	1.8	1.9	2.0	V
Green Mode end voltage	1.4	1.5	1.6	V
Burst Mode voltage	0.85	0.95	1.05	V
Hysteresis		100		mV
OLP trip level, Vcomp	4.2	4.4	4.6	V
OLP delay time		64		ms
CURRENT SENSING (CS Pin)				
Maximum input voltage, VCS(OFF)	0.8	0.85	0.9	V
=Leading-edge blanking time		350		nS
Input impedance	1			MΩ
Delay to Output*		100		nS
Cs OTP Level		0.7		V
Cs OTP de-bounce time		4		ms
The protection level of output diode Short circuit		0.9		V
De-bounce time of output diode Short circuit protection		4		cycles

Electrical Characteristics (TA = +25°C unless otherwise stated, VCC = 15.0V)

Parameter	Min.	Typ.	Max.	Unit
ZCD (ZCD Pin)				
ZCD IOVP level		150		uA
OVP De-bounce Time*		4		cycle
UVP Level		0.8		V
After UVP De-bounce Time		4		cycle
OSCILLATOR				
CCM Frequency @ Low line	58	65	72	kHz
Green Mode Frequency	21	24	27	kHz
Jitter Frequency (CCM Mode)		±9		%
Soft Start Time (CS Pin)				
Soft Start Time*	6	8	10	ms
GATE DRIVER OUTPUT (OUT Pin)				
Output low level, VCC = 18V, Io = 20mA			1	V
Output high level, VCC = 18V, Io = 20mA	8			V
Rising time, load capacitance = 1000pF*	300	400	500	ns
Falling time, load capacitance = 1000pF*	35	50	65	ns
VGATE-clamp (VCC = 20V)		12.5		V
Maximun duty cycle	75	80	85	%
Internal OTP (Guaranteed by Design)				
OTP*		140		°C
Hysteresis*		30		°C

* Guaranteed by Design.

Typical Performance Characteristics

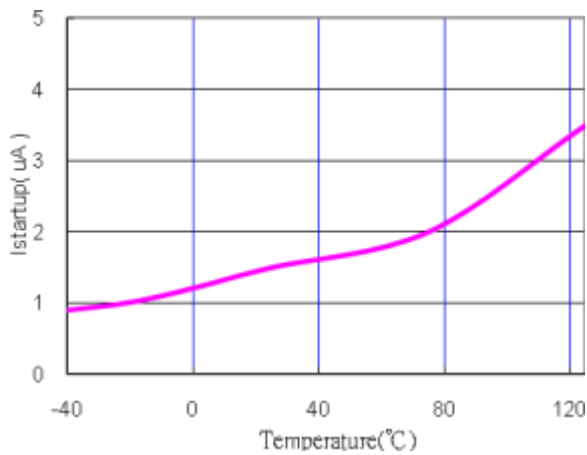

Fig. 1 I_{startup} (µA) vs. Temperature

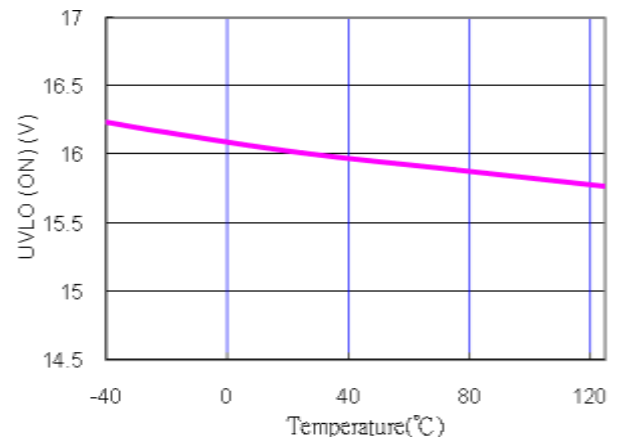

Fig. 2 UVLO (ON) (V) vs. Temperature

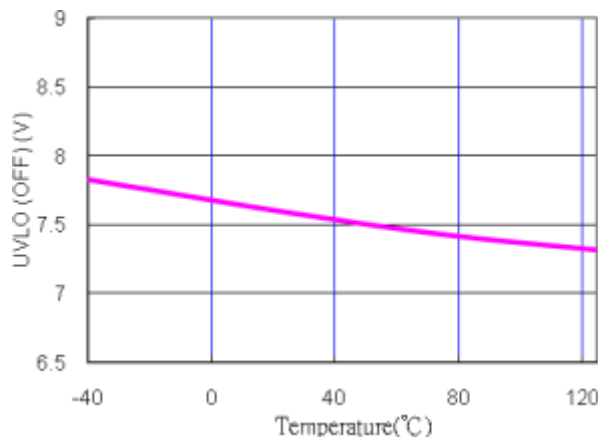

Fig. 3 UVLO (OFF) (V) vs. Temperature

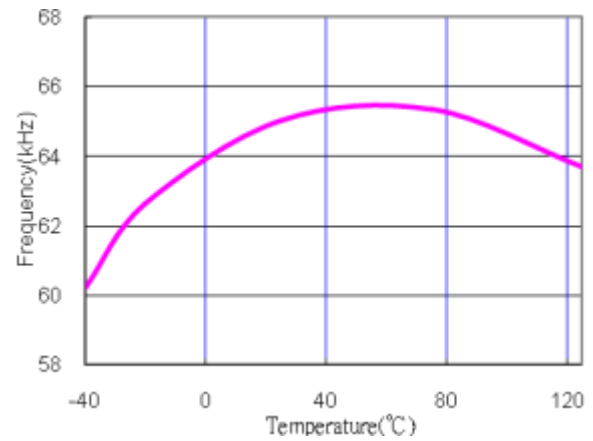

Fig. 4 CCM Frequency (kHz) vs. Temperature

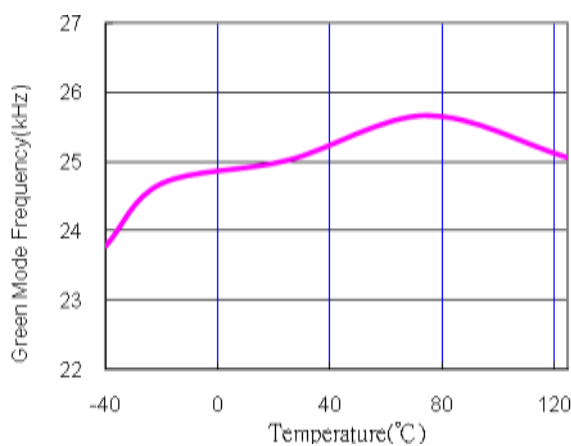

Fig. 5 Green Mode Frequency (kHz) vs. Temperature

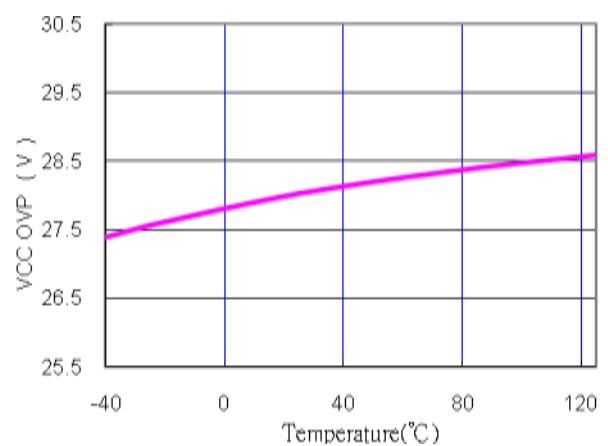

Fig. 6 VCC OVP (V) vs. Temperature

Application Information

Overview

GR1281 series is a highly-integrated, low startup current, current mode PWM controller with green-mode function. This results in a low-cost solution for low power AC/DC adapters. It integrated more functions to reduce the external components counts and the size. Its major features are described as below.

Start-up Current

The typical start-up current is 2uA. Very low start-up current allows the PWM controller to increase the value of start-up resistor and then reduce the power dissipation on it.

Under-voltage Lockout (UVLO)

A hysteresis UVLO comparator is implemented in GR1281 series, then the turn-on and turn-off thresholds level are fixed at 16V and 8V respectively. This hysteresis ensures that the start-up capacitor will be adequate to supply the chip during start-up. The hysteresis is show in Fig. 7

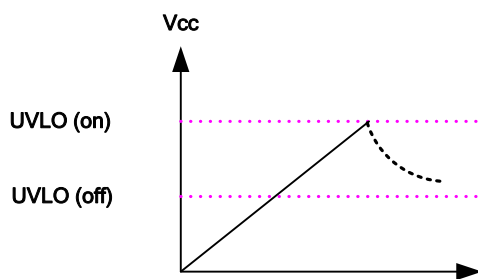

Fig.7

Leading-edge Blanking (LEB)

Each time the power MOSFET is switched on, a turn-on spike will inevitably occur at the sense resistor. To avoid fault trigger, a leading-edge blanking time is built in. During this blanking period, the current-limit comparator is disabled and cannot switch off the gate driver.

Over-voltage Protection (OVP) on VCC Auto Recovery mode

Over-voltage Protection is implemented in GR1281 series for being damaged from abnormal condition. When VCC voltage is higher than OVP level, the Output of Gate driver will be shut down. VCC OVP is auto-recovery. Once the condition of over voltage happened, the Gate driver will be shut down until the next turn-ON. This operation is an Hiccup mode. (Fig.8)

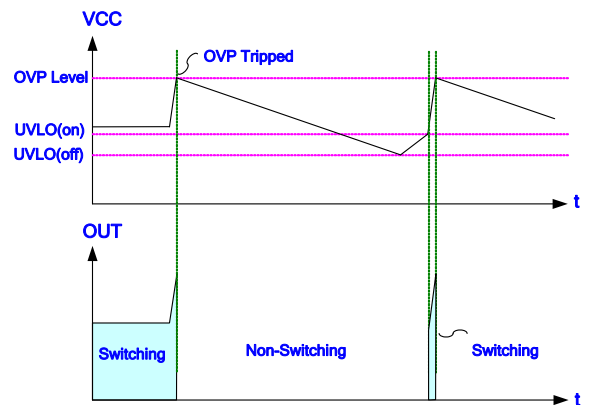

Fig.8

Output OVP on ZCD - Auto Recovery mode

An output overvoltage protection is implemented in GR1281 series, as shown in Fig. 9. It senses the auxiliary voltage via the resistors. The overvoltage protection works by sampling I_{zcd} after a delay time. The sampling current level is compared with internal I_{ovp} . If $I_{zcd} = (N_{vcc} - 4.6) / R1$ is large than 150uA ZCD OVP circuit switches the power MOSFET off. ZCD OVP function is an auto-recovery type protection.

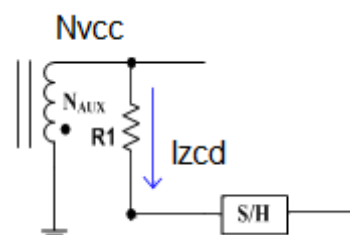

Fig 9

Output Under-voltage Protection (UVP) on ZCD – Auto Recovery mode

To protect the circuit from damage due to output short condition, an auto-recovery type of UVP protection is implemented for it. If the QRD voltage declines below 0.8V for over 4cycle, the protection will be activated to turn off the gate until the next UVLO-ON.

Adjustable H/L Line compensation

The circuit auxiliary winding R1 and connecting ZCD pin for keeping in VIN voltage consistency. The relation of IZCD and IOCP is $IOCP=0.5*IZCD$. The CS OCP source current, which via the resistors of R and Rcs, could compensates Voltage (ΔVcs) because input voltage in H line makes Voltage Offset, as shown in Fig.11.

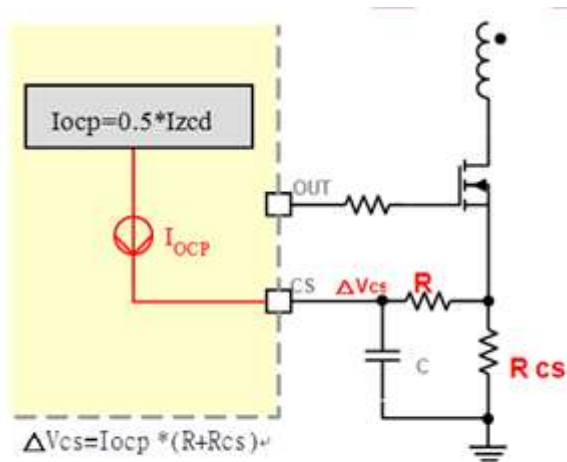

Fig.11

Gate Clamp/Soft Driving

Driver output is clamped by an internal 12.5V

clamping circuit to prevent from undesired over-voltage gate signals. And under the conditions listed below, the gate output will turn off immediately to protect the power circuit. GR1281 series also has soft driving function to minimize EMI.

VCC Mode

In order to avoid the output voltage shut down by load changing from full to no load, GR1281 series is built-in the VCC mode function. When the load from full changes to no load, the output voltage will overshoot and pull low the COMP pin by feedback loop (Into burst mode). Thus the duty will disappear and no power delivers to the secondary. If there is without any mechanism to prevent this situation, the VCC pin voltage will down to UVLO off and the IC will re-start again.

The VCC mode function is used to prevent the output re-start again when load changes. So never let the system operate on the VCC mode at no load. The system should operate on burst mode, otherwise the input power maybe become larger.

Package Information

SOT-26

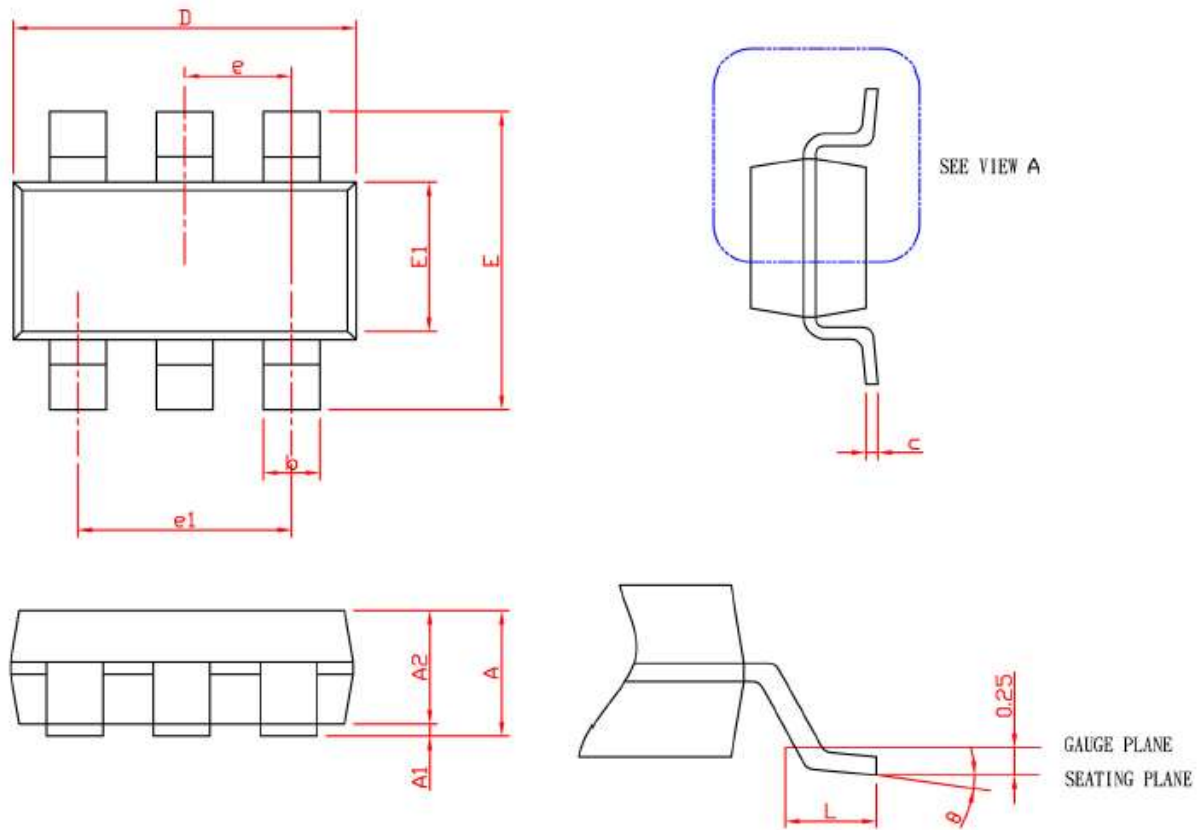

SYMBOL	SOT-26			
	MILLIMETERS		INCHES	
	MIN.	MAX.	MIN.	MAX.
A		1.45		0.057
A1	0.00	0.15	0.000	0.006
A2	0.90	1.30	0.035	0.051
b	0.30	0.50	0.012	0.020
c	0.08	0.22	0.003	0.009
D	2.70	3.10	0.106	0.122
E	2.60	3.00	0.102	0.118
E1	1.40	1.80	0.055	0.071
e	0.95 BSC		0.037 BSC	
e1	1.90 BSC		0.075 BSC	
L	0.30	0.60	0.012	0.024
θ	0°	8°	0°	8°

Note: 1. Followed from JEDEC MO-178 AB.

2. Dimension D and E1 do not include mold flash, protrusions or gate burrs. Mold flash, protrusions or gate burrs shall not exceed 10 mil per side

Carrier Tape & Reel Dimensions

SOT-26

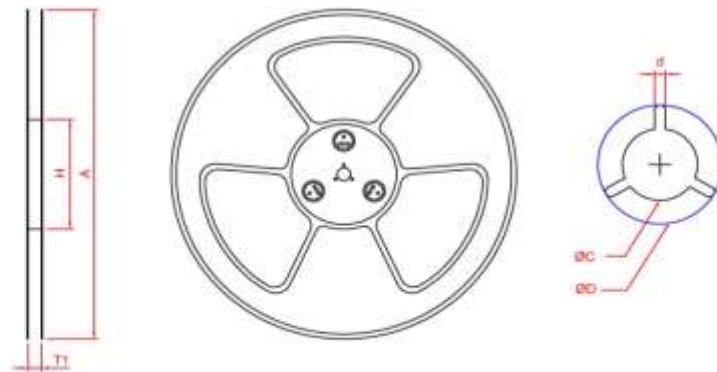
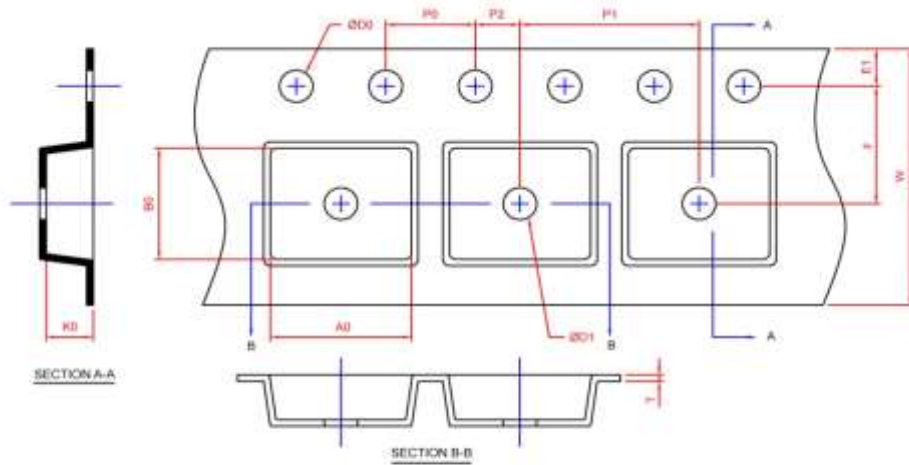

Application	A	H	T1	C	d	D	W	E1	F
SOT-26	178.0±2.00	50 MIN.	8.4+2.00 -0.00	13.0+0.50 -0.20	1.5 MIN.	20.2 MIN.	8.0±0.30	1.75±0.10	3.5±0.05
	P0	P1	P2	D0	D1	T	A0	B0	K0
	4.0±0.10	4.0±0.10	2.0±0.05	1.5+0.10 -0.00	1.0 M----IN.	0.6+0.00 -0.40	3.20±0.20	3.10±0.20	1.50±0.20

Application	Carrier Width	Cover Tape Width	Devices Per Reel
SOT-26	8	5.3	3000

(mm)

Tape and Specification Reel

SOT 26

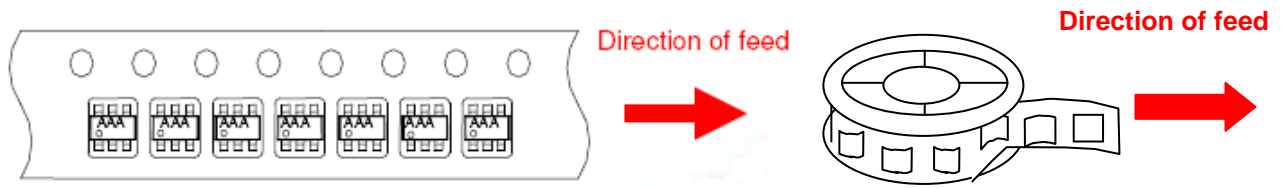

Nanjing Greenchip Semiconductor Co., Ltd.(Greenergy OPTO Inc.) reserves the right to make corrections, modifications, enhancements, improvements, and other changes to its products and services at any time and to discontinue any product or service without notice. Customers should obtain the latest relevant information before placing orders and should verify that such information is current and complete.

Revision History

Ver.	Date	Change Notice
A	2018/11/16	GR1281 · release

X-ON Electronics

Largest Supplier of Electrical and Electronic Components

Click to view similar products for [Switching Voltage Regulators](#) category:

Click to view products by [Greenergy](#) manufacturer:

Other Similar products are found below :

[FAN53610AUC33X](#) [FAN53611AUC123X](#) [MP2374DS-LF-Z](#) [EN6310QA](#) [NCP81108MNTXG](#) [NCP81109BMNTXG](#) [FAN48610BUC45X](#)
[FAN48617UC50X](#) [R3](#) [KE177614](#) [EP5358LUA](#) [MPQ4423GQ-AEC1-Z](#) [FAN53611AUC12X](#) [MAX809TTR](#) [NCV891234MW50R2G](#)
[AST1S31PUR](#) [NCP81103MNTXG](#) [NCP81203PMNTXG](#) [NCP81208MNTXG](#) [NCP81109GMNTXG](#) [SCY1751FCCT1G](#)
[NCP81109JMNTXG](#) [MP2161AGJ-Z](#) [NCP81241MNTXG](#) [MP2388GQEU-Z](#) [MPQ4481GU-AEC1-P](#) [MP8756GD-P](#) [MPQ2171GJ-P](#)
[MPQ2171GJ-AEC1-P](#) [MP2171GJ-P](#) [NCV1077CSTBT3G](#) [MP28160GC-Z](#) [MPM3509GQVE-AEC1-P](#) [LTM4691EV#PBF](#) [XCL207A123CR-](#)
[G](#) [XDPE132G5CG000XUMA1](#) [XDPE12284C0000XUMA1](#) [LTM4691IV#PBF](#) [MP5461GC-P](#) [MP28301GG-P](#) [MIC23356YFT-TR](#)
[ISL95338IRTZ](#) [MP3416GJ-P](#) [BD9S201NUX-CE2](#) [ISL9113AIRAZ-T](#) [MP5461GC-Z](#) [MPQ2172GJ-AEC1-Z](#) [MPQ4415AGQB-Z](#)
[MPQ4590GS-Z](#) [IR3888AMTRPBFAUMA1](#)