

Linear Fan Speed Controller with OTP Function

Features

- Linear fan speed controller
- Wide fan speed control range
- Programmable anti-lock start up timer
- Programmable minimum fan speed
- Adjustable fan speed curve slope
- Programmable knee point and OTP point
- OTP protection with fault output
- NTC thermistor open full speed operation
- SOT-26 package

Applications

- LCD TV power supply
- Game machine power supply
- Industrial or medical power supply
- PC power supply
- Server power supply

Description

The GR8030 is designed for programming the curve of DC fan speed versus temperature via a NTC thermistor and few counts of passive components. The speed curve includes anti-lock with full speed operation time, minimum fan speed when at idle state, a knee point where fan speed starts to accelerate when temperature over the set point, a programmable slope of fan speed versus temperature, and OTP (over-temperature protection) trig point. The GR8030 sends a low level on FSC pin when the OTP pin is lower than the set point of temperature protection level. It is also built-in the NTC thermistor open with full speed operation function.

Ordering and Marking Information

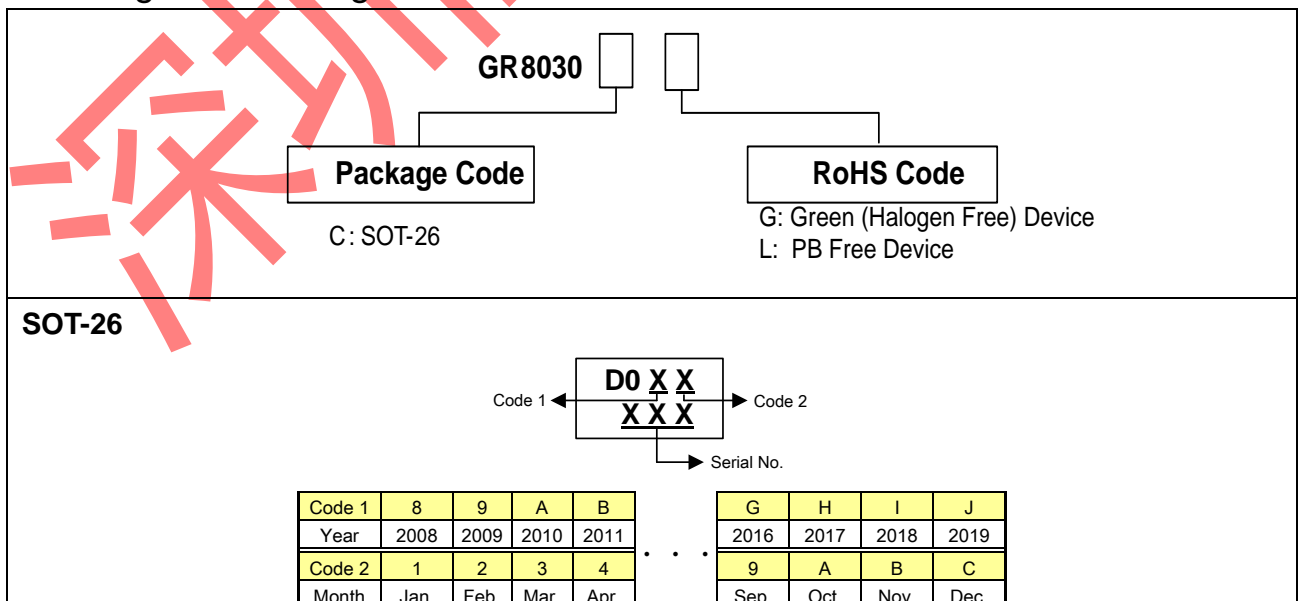

Greenergy OPTO Inc. reserves the right to make changes to improve reliability or manufacture ability without notice, and advise customers to obtain the latest version of relevant information to verify before placing orders.

Pin Configuration

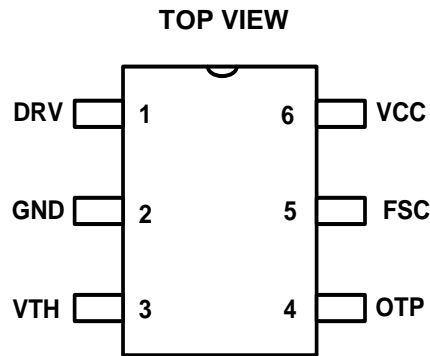

Pin Description

Pin No.	Symbol	Description
1	DRV	Drive external BJT base
2	GND	Ground
3	VTH	Temperature sensor (NTC thermistor) input
4	OTP	Over-temperature trip point
5	FSC	Set minimum fan speed; output of OTP flag
6	VCC	Power supply

Absolute Maximum Ratings

Supply voltage VCC	-----	+20V
DRV, VTH, VFSC, OTP	-----	-0.3 ~ VCC+0.3V
Junction temperature	-----	150°C
Operating ambient temperature	-----	-20°C ~ 85°C
Storage temperature range	-----	-65°C ~ 150 °C
SOT-26 package thermal resistance	-----	250°C/W
Power dissipation (SOT-26, at ambient temperature = 85°C)	-----	250mW
Lead temperature (All Pb free packages, soldering, 10 sec)	-----	260°C
ESD voltage protection, human body model	-----	2KV
ESD voltage protection, machine model	-----	200V

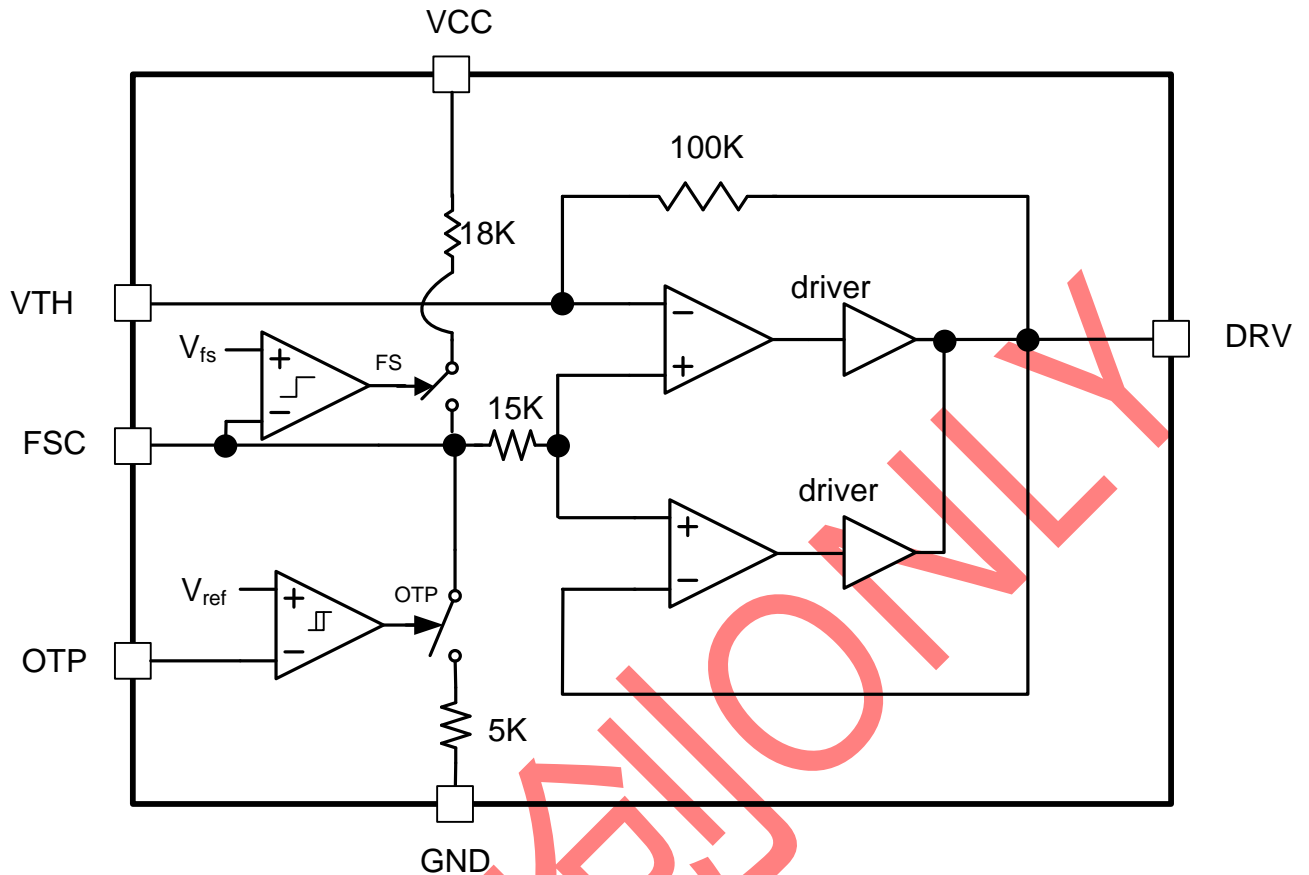
Block Diagram

Electrical Characteristics ($V_{CC} = 12V$ and $T_A = 25^\circ C$, unless otherwise specified)

Parameter	Conditions	Symbol	Min.	Typ.	Max.	Unit
Operating voltage		VCC	10		17	V
Operating current	DRV pin open	I_{CC}		200	300	μA
Start up voltage		V_{ST}		5		V
OTP detect voltage divider factor	$V_{OTP_IN} = V_{CC}/K_{OTP_IN}$	K_{OTP_IN}	2.92	2.96	3.00	
OTP release voltage divider factor	$V_{OTP_OUT} = V_{CC}/K_{OTP_OUT}$	K_{OTP_OUT}	2.56	2.62	2.67	
OTP detect voltage hysteresis	$V_{CC} = 12V$	V_{OTP_HS}		500		mV
	$V_{CC} = 17V$			710		mV
NTC open full speed operation (OTP pin trig point)	$V_{CC}=12V$		10.9		11.7	V
OTP pull low resistance		R_{OTP}	2.1	3	3.9	k Ω
Output clamping voltage	$V_{CC} = 17V$	V_{CLAMP}	12	14	16	V

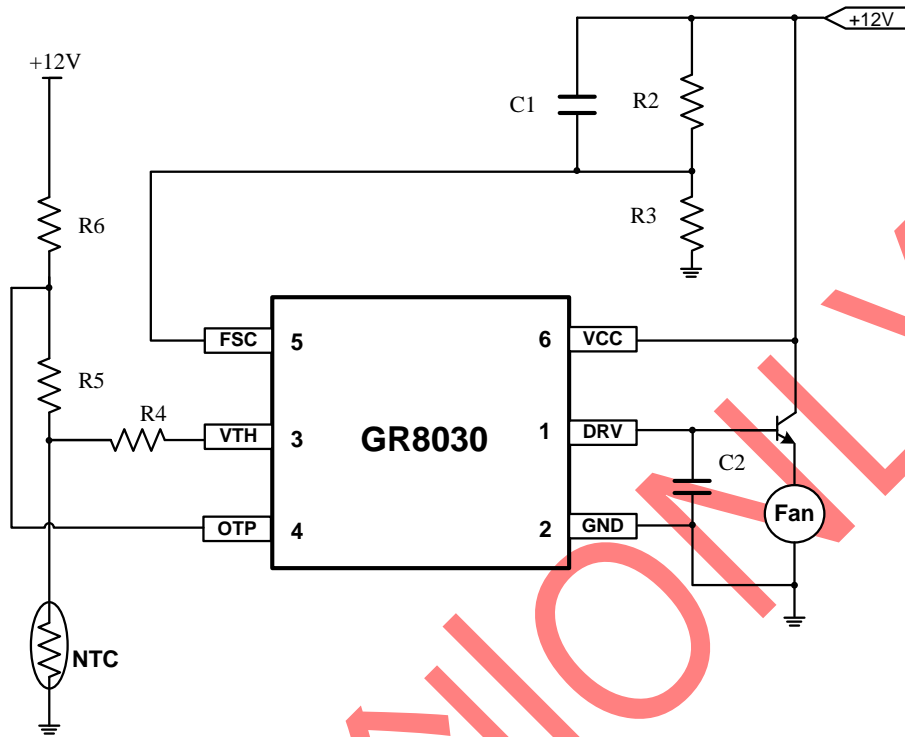
Typical Application Circuit

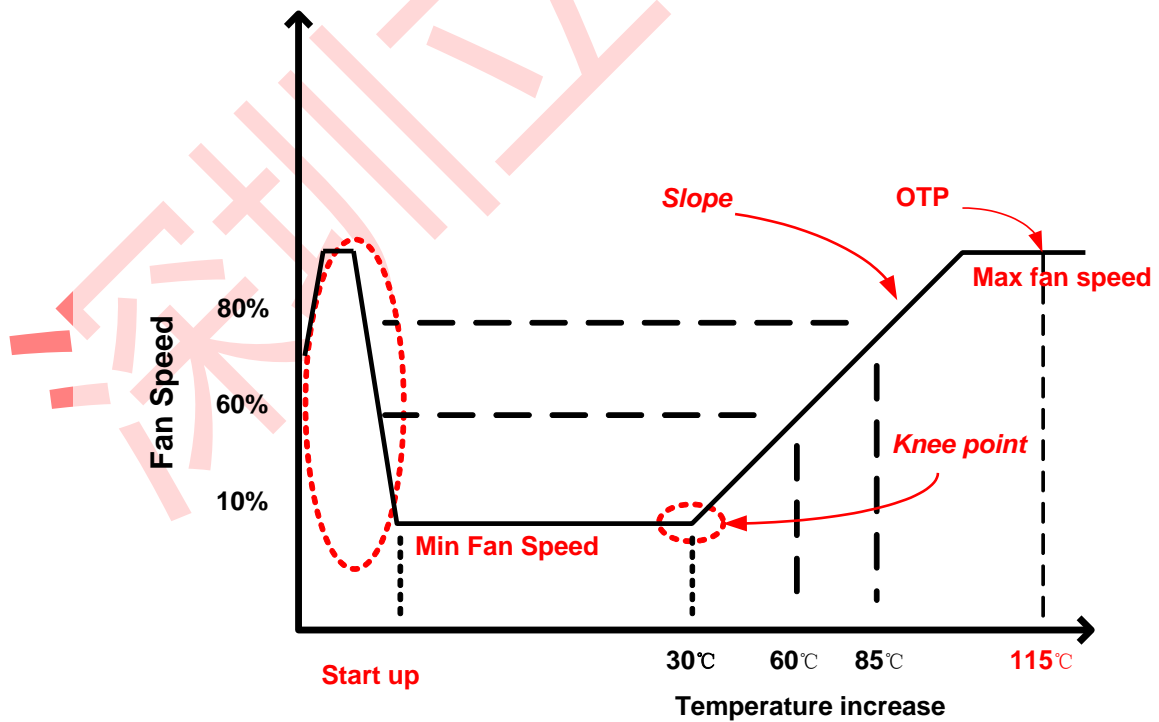

Typical Fan Speed Curve



Application Information

Minimum Fan Speed

The FSC pin is used to set the minimum output voltage of DRV pin (set the idle speed of fan). The level is decided by a voltage divider.

$$V_{FSC} = \frac{R_3}{R_2 + R_3} VCC$$

Knee Point

The DC fan begins to speed up at a specific temperature named knee point. The knee point can be changed by the resistors R5 and R6 in series with the NTC. R5 and R6 can be decided by below formula.

$$R_5 + R_6 = \frac{VCC - V_{FSC}}{V_{FSC}} \times R_{NTC}(T_KNEE)$$

Where $R_{NTC}(T_KNEE)$ is the resistance at knee point you set. A user can find the value from thermistor datasheet.

The Slope of Speed V.S. Temperature

By adjusting R4, the IC can provide different slope of the fan speed versus temperature curve. R_{NTC} is an approximated value during the slope range.

$$Slope = \frac{100K}{R_4 + (R_5 + R_6) \parallel R_{NTC}}$$

Maximum Fan Speed

The DRV pin will pull high to 12V for maximum fan speed in 12V system. However, in 17V system, the DRV pin will be clamped at 14V for maximum fan speed limitation and protect fan from damaged.

Anti-lock Start Up Timer

At start-up period, the DRV pin will output 12V. It drives the fan with maximum speed for a set period of time then drops to minimum voltage. The period

could be changed with different time constant $\tau = C_1 * (R_2 // R_3)$. The period of time is about 1.5τ for 12V supply voltage and 2τ for 17V supply voltage.

Over-temperature Protection

When the voltage of OTP pin is lower than the Vref, the DRV pin will output 12V to drive fan as maximum fan speed and the FSC pin will be pulled to low. Where $Vref = VCC * K_{OTPIN}$. Once the NTC thermistor is opened in accidentally, the DRV pin also outputs the high to fully drive the fan. In such situation, the voltage on OTP pin will higher enough to trig the NTC open comparator trip point 10.9V in minimum. The designer should take care the R5, R6 and NTC thermister value at lower temperature. While at lower temperature, the OTP pin may be higher than NTC open trip point. The designer should be sure the voltage on OTP pin is lower than 10.9V at lower temperature. Or the designer does not need the NTC open protection function, that could parallel one 8~9V Zener diode on OTP pin to disable the function as shown in below figure.

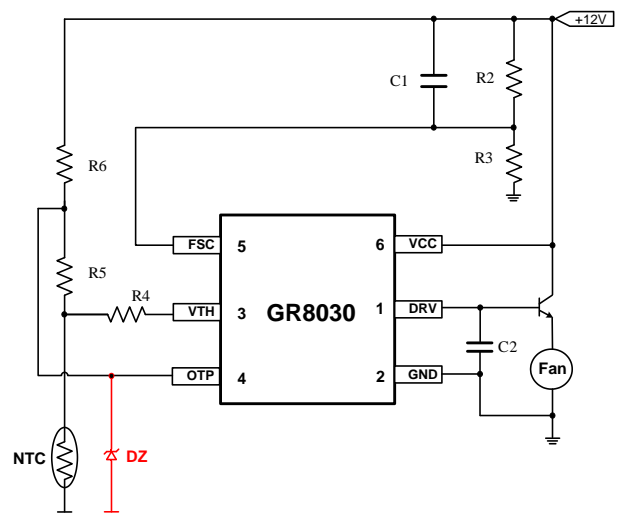

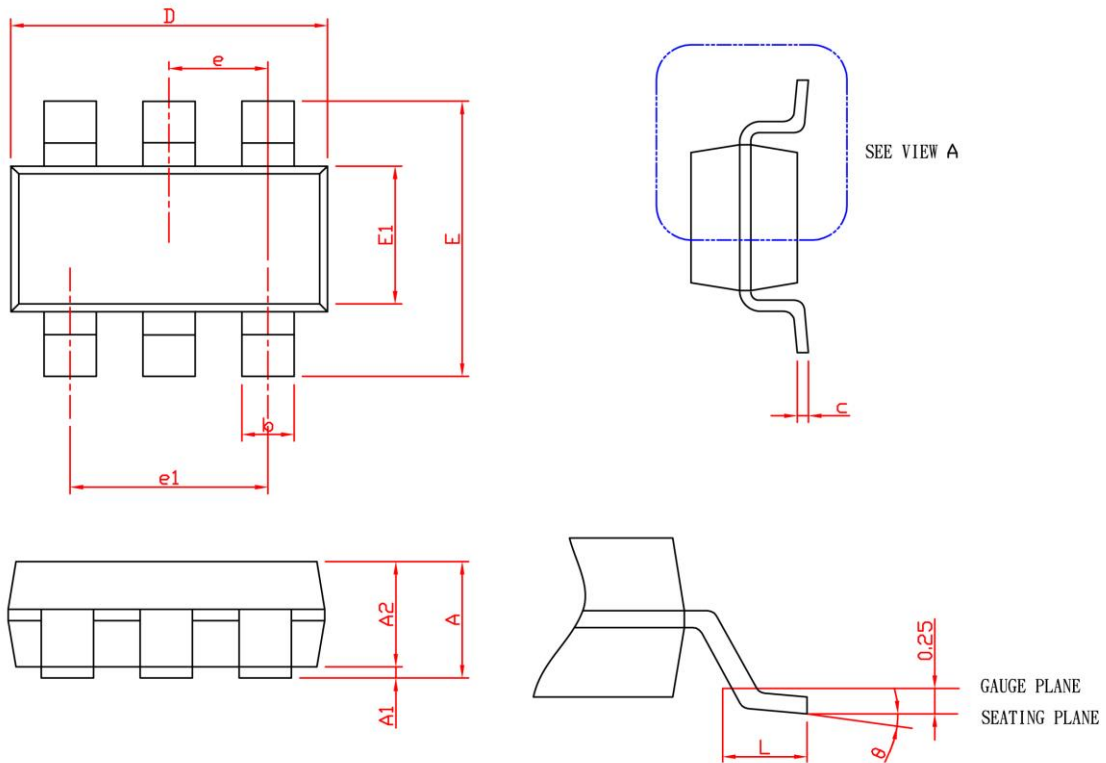
Package Information

SYMBOL	SOT-26			
	MILLIMETERS		INCHES	
	MIN.	MAX.	MIN.	MAX.
A		1.45		0.057
A1	0.00	0.15	0.000	0.006
A2	0.90	1.30	0.035	0.051
b	0.30	0.50	0.012	0.020
c	0.08	0.22	0.003	0.009
D	2.70	3.10	0.106	0.122
E	2.60	3.00	0.102	0.118
E1	1.40	1.80	0.055	0.071
e	0.95 BSC		0.037 BSC	
e1	1.90 BSC		0.075 BSC	
L	0.30	0.60	0.012	0.024
θ	0°	8°	0°	8°

Note : 1. Followed from JEDEC TO-178 AB.

2. Dimension D and E1 do not include mold flash, protrusions or gate burrs. Mold flash, protrusions or gate burrs shall not exceed 10 mil per side.

Carrier Tape & Reel Dimensions

SOT-26

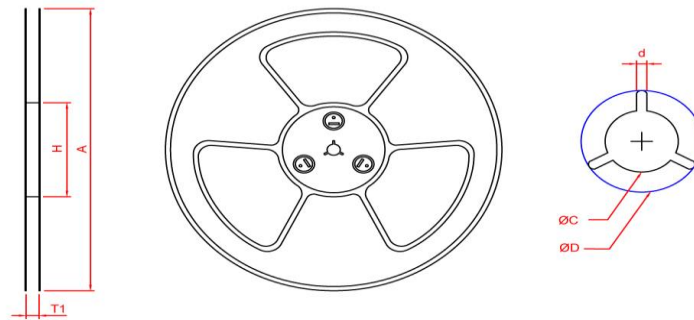
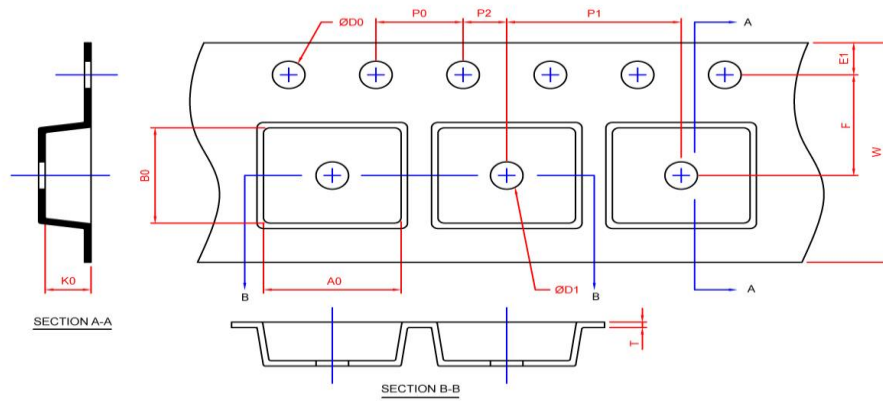

Application	A	H	T1	C	d	D	W	E1	F
SOT-26	178.0±2.00	50 MIN.	8.4+2.00 -0.00	13.0+0.50 -0.20	1.5 MIN.	20.2 MIN.	8.0±0.30	1.75±0.10	3.5±0.05
	P0	P1	P2	D0	D1	T	A0	B0	K0
	4.0±0.10	4.0±0.10	2.0±0.05	1.5+0.10 -0.00	1.0 MIN.	0.6+0.00 -0.40	3.20±0.20	3.10±0.20	1.50±0.20

(mm)

Application	Carrier Width	Cover Tape Width	Devices Per Reel
SOT -26	8	5.3	3000

Taping direction information

SOT-26

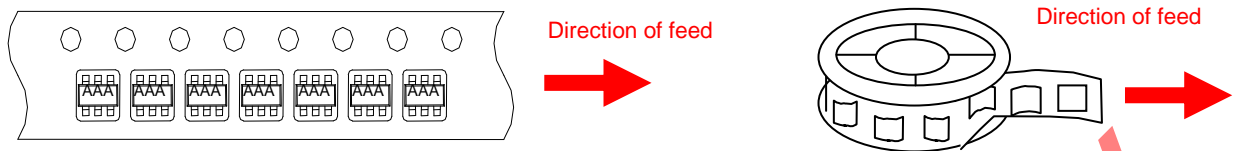

深圳立包ONLY

Greenergy OPTO, Inc. reserves the right to make corrections, modifications, enhancements, improvements, and other changes to its products and services at any time and to discontinue any product or service without notice. Customers should obtain the latest relevant information before placing orders and should verify that such information is current and complete.

X-ON Electronics

Largest Supplier of Electrical and Electronic Components

Click to view similar products for [Motor/Motion/Ignition Controllers & Drivers](#) category:

Click to view products by [Greenergy](#) manufacturer:

Other Similar products are found below :

[LV8133JA-ZH](#) [LV8169MUTBG](#) [LV8774Q-AH](#) [LV8860PV-TLM-H](#) [MC33931EKR2](#) [FSB50250UTD](#) [FSB50550TB2](#) [FSBF15CH60BTH](#)
[FSBS10CH60T](#) [MP6507GR-P](#) [MP6508GF](#) [MSVCPM2-63-12](#) [MSVGW45-14-2](#) [MSVGW54-14-5](#) [NTE7043](#) [CAT3211MUTAG](#) [LA6245P-CL-TLM-E](#) [LA6245P-TLM-E](#) [LA6565VR-TLM-E](#) [LB11650-E](#) [LB1694N-E](#) [LB1837M-TLM-E](#) [LB1845DAZ-XE](#) [LC898111AXB-MH](#)
[LC898300XA-MH](#) [SS30-TE-L-E](#) [STK531-345A-E](#) [STK581U3A0D-E](#) [STK58AUNP0D-E](#) [STK621-068C-E](#) [STK621-140C](#) [STK621-728S-E](#)
[STK625-728-E](#) [STK672-400B-E](#) [STK672-432AN-E](#) [STK672-432BN-E](#) [STK672-440AN-E](#) [STK672-442AN-E](#) [AMIS30621AUA](#)
[FSB50550ASE](#) [26700](#) [LV8161MUTAG](#) [LV8281VR-TLM-H](#) [LV8702V-TLM-H](#) [LV8734VZ-TLM-H](#) [LV8773Z-E](#) [LV8807QA-MH](#)
[MC33932EK](#) [MCP8024T-H/MP](#) [TND027MP-AZ](#)