

4-Channel Supervisor IC for Power Supply with OCP & OTP Protections

Features

- Over-voltage protection and lockout for 3.3V, 5V, and two 12V power supplies
- Under-voltage protection and lockout for 3.3V, 5V, and two 12V power supplies
- Over-current protection and lockout for 3.3V, 5V and two 12V power supplies
- Open drain output for PGO and FPO/ pins
- 300mS power good delay
- 75mS delay for under voltage and over current protection
- 38mS for PSON/ de-bounce
- 73uS width noise de-glitches
- Wide power supply voltage range
- Special care for AC power off
- Programmable over-temperature protection

Applications

- PC power supply
- LCD TV power supply

Description

The GR8323N is designed to monitor the outputs of switching power supply and generates the power good signal to inform the system. It provides over-voltage protection, under-voltage protection, over-current protection, and power good signal generating. The over-voltage protection (OVP) and under-voltage protection (UVP) monitor 3.3V, 5V and two 12V to protect the power supply and system. Over-current protection (OCP) monitors IS33, IS5, IS12A, IS12B input current sense. An adjustable over-current trip point composed of Iref and a setting resistor help users design the OCP easily. The over-temperature protection (OTP) input has hysteresis function. GR8323N will shutdown in OTP condition. The power-good feature issues a power-good signal when the output is ready; therefore, the GR8323N provides a reliable power supply environment for the system.

Ordering and Marking Information

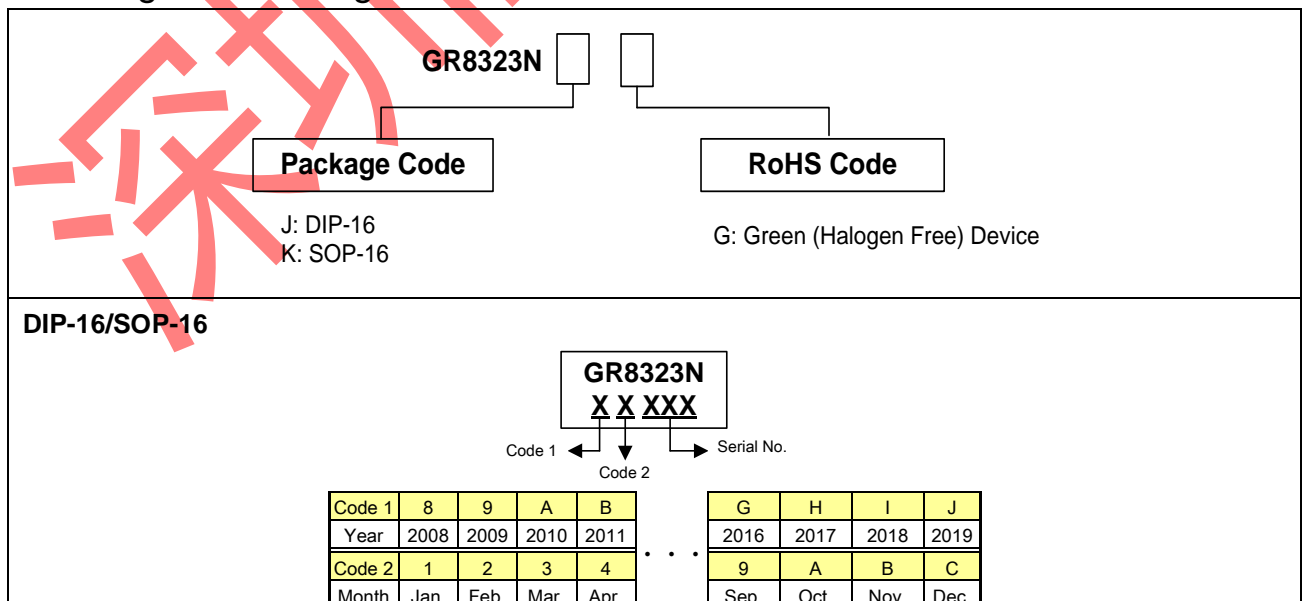

Greenergy OPTO Inc. reserves the right to make changes to improve reliability or manufacture ability without notice, and advise customers to obtain the latest version of relevant information to verify before placing orders.

Pin Configuration

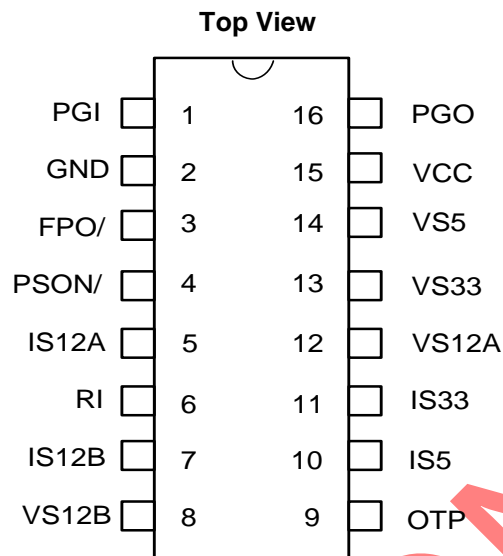

Pin Descriptions

Pin No	Name	I/O	Description
1	PGI	I	Power good input pin
2	GND		Ground
3	FPO/	O	Fault protection output pin, open drain output
4	PSON/	I	ON/OFF control input pin
5	IS12A	I	12V over current protection sense input
6	RI	I	Reference current setting adjust input
7	IS12B	I	12V over current protection sense input
8	VS12B	I	12V over/under voltage sense input
9	OTP	I	Over temperature protection input pin
10	IS5	I	5V over current protection sense input
11	IS33	I	3.3V over current protection sense input
12	VS12A	I	12V over/under voltage sense input
13	VS33	I	3.3V over/under voltage sense input
14	VS5	I	5V over/under voltage sense input
15	VCC	I	Power supply
16	PGO	O	Power good output signal pin, open drain output

Absolute Maximum Ratings

VCC, VS12A/B, IS12A/B, PGI, FPO/	-----	-0.5 ~ 16V
VS5, IS5	-----	-0.5 ~ 9V
VS33, IS33	-----	-0.5 ~ 7V
PSON/, OTP, PGO	-----	-0.5 ~ VCC + 0.5V
Junction temperature	-----	150°C
Operating ambient temperature	-----	-20°C ~ 85°C
Storage temperature range	-----	-65°C ~ 150°C
DIP-16 package thermal resistance	-----	100°C/W
Power dissipation (DIP-16, at ambient temperature = 85°C)	-----	650mW
Lead temperature (All Pb free packages, soldering, 10 sec)	-----	260°C
ESD voltage protection, human body model	-----	3KV
ESD voltage protection, machine model	-----	250V

Recommended Operating Conditions

Item	Min.	Max.	Unit
Supply voltage VCC	5	15	V
OCP sense resistor	2		m Ω

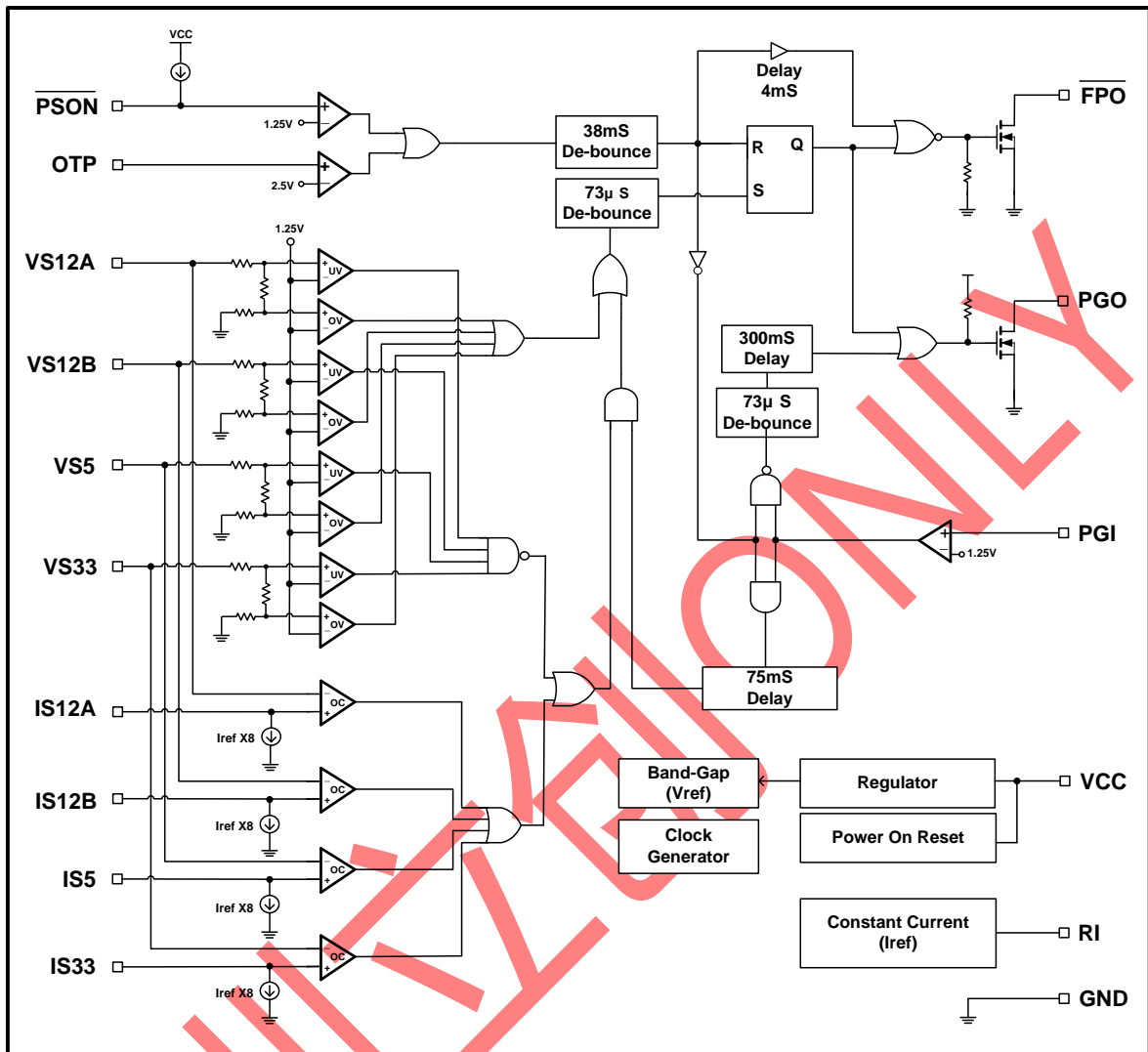
Block Diagram

Timing Chart

1. PSON/ Signal Characteristics

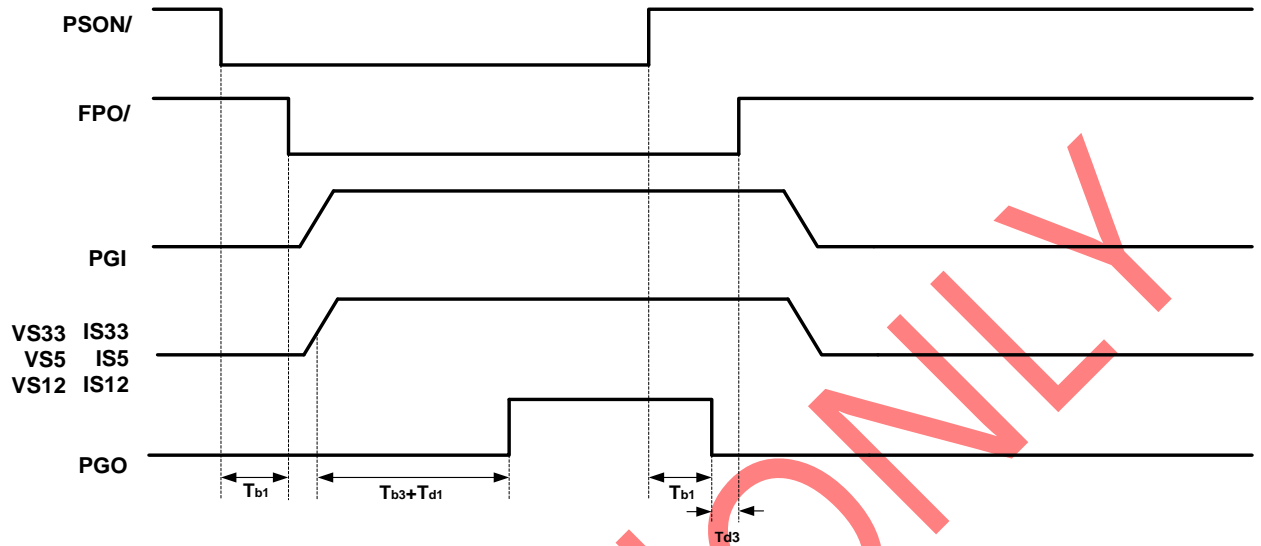

2. Over-voltage and Over-current Characteristics

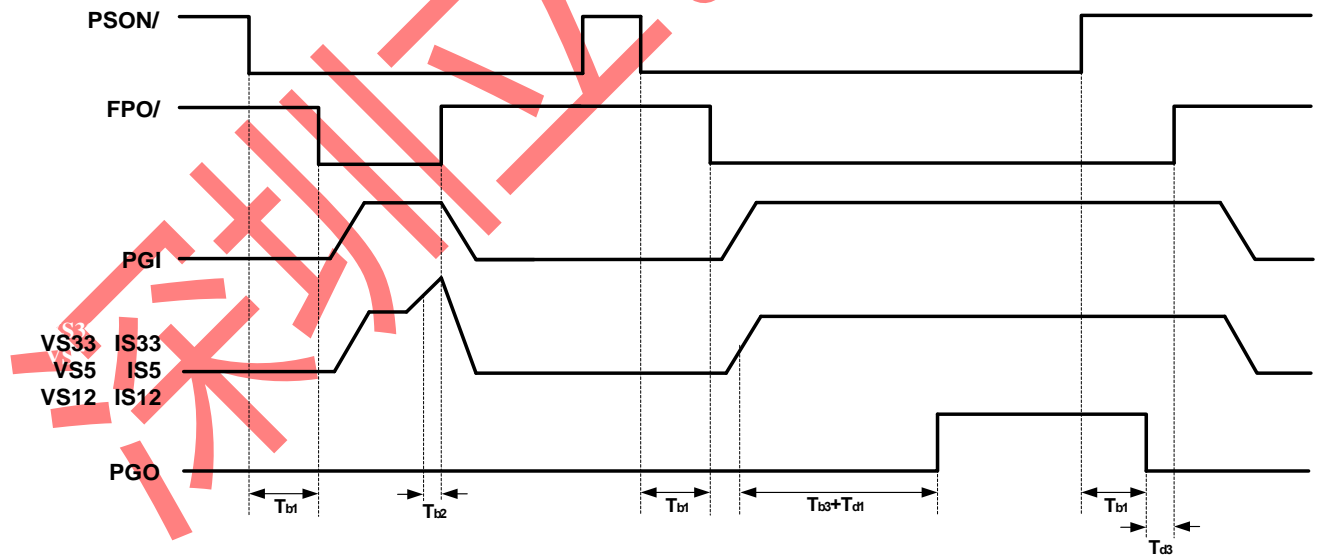

Timing Chart (Cont.)

3. Under-voltage Characteristics

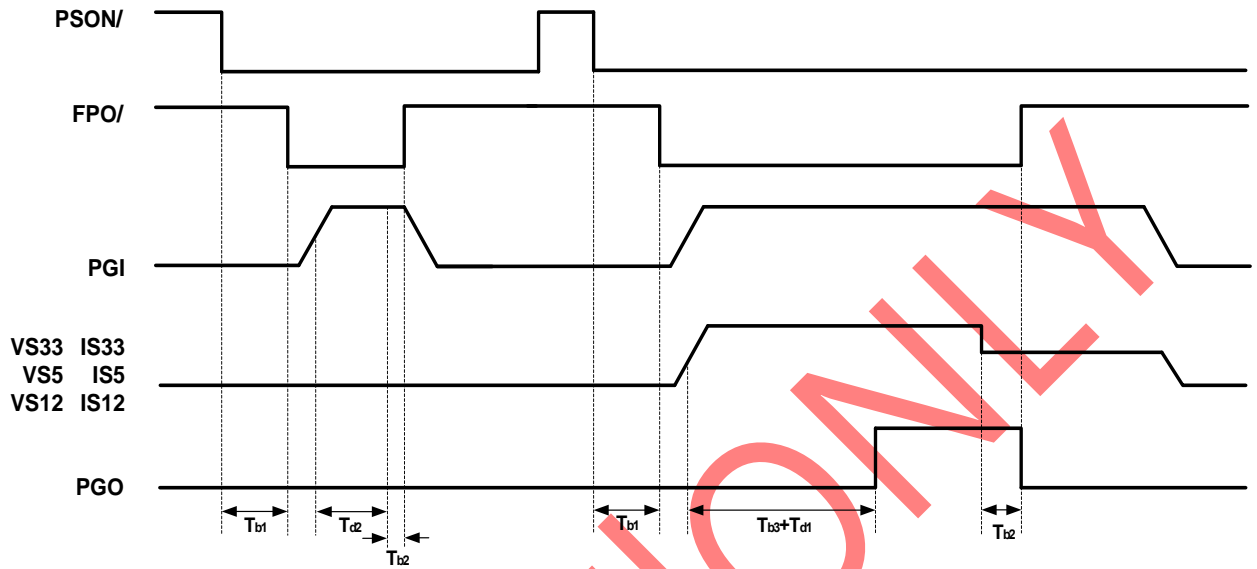

4. PGI Characteristics

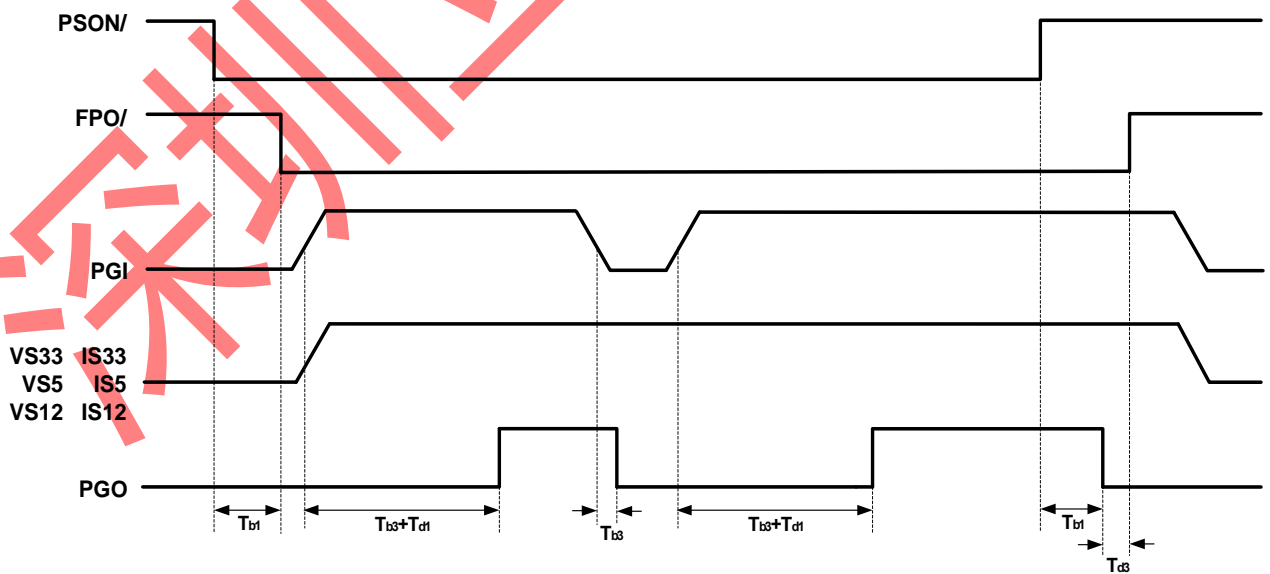

Electrical Characteristics ($V_{CC} = 5V, T_a = 25^\circ C$)

Parameter	Conditions	Symbol	Min.	Typ.	Max.	Unit
POWER SUPPLY						
Supply voltage		VCC	4	5.0	16.0	V
Supply current	$V_{PSON/} = 5V$	Ivcc			1	mA
OVER-VOLTAGE PROTECTION						
Over-voltage threshold		VS33	3.7	3.9	4.1	V
		VS5	5.7	6.1	6.5	V
		VS12A/B	13.1	13.8	14.5	V
UNDER-VOLTAGE PROTECTION						
Under-voltage threshold		VS33	2.0	2.2	2.4	V
		VS5	3.3	3.5	3.7	V
		VS12A/B	8.5	9.0	9.5	V
OVER-CURRENT PROTECTION						
Constant current		I _{ref}	12.5	20.0	62.5	uA
Ratio of IS sink current to I _{R1}			7.6	8	8.4	
Offset voltage of OCP comparators		V _{offset}	-3		3	mV
PSON/						
High-level input threshold voltage		V _{IH}	1.4	1.5		V
Low-level input threshold voltage		V _{IL}		1.0	1.1	V
PGI AND PGO, FPO/						
PGI threshold voltage		V _{PGI}	1.16	1.25	1.33	V
Threshold voltage for Td2		V _{PGI,Td2}	0.60	0.63	0.75	V
Threshold voltage for UV, OC		V _{PGI}	1.05	1.13	1.21	V
PGI hysteresis		V _{PGI}	±20	±50	±80	mV
Leakage current (PGO)	$V_{PGO} = 5V$	I _{LKG}			5	uA
Low level output voltage (PGO)	$I_{SINK} = 10mA$	V _{OL}			0.35	V
Leakage current (FPO/)	$V_{FPO/} = 5V$	I _{LKG}			5	uA
Low level output voltage(FPO/)	$I_{SINK} = 10mA$	V _{OL}			0.35	V
OVER-TEMPERATURE PROTECTION						
Threshold voltage		V _{TH}	2.4	2.5	2.6	V
Hysteresis		V _{HYST}		-0.26		V

Electrical Characteristics (Cont.)

Parameter	Conditions	Symbol	Min.	Typ.	Max.	Unit
SWITCHING CHARACTERISTICS						
PSON/ de-bounce time		Tb1	24	38	61	mS
FPO/ noise de-glitch time		Tb2	47	73	110	uS
PGO noise de-glitch time		Tb3	47	73	110	uS
PGI to PGO delay time		Td1	200	300	480	mS
UVP/OCP protection delay time		Td2	49	75	114	mS
PGO to FPO/ delay time		Td3	2	4	6	mS

深圳立包ONLY

Typical Application Circuit

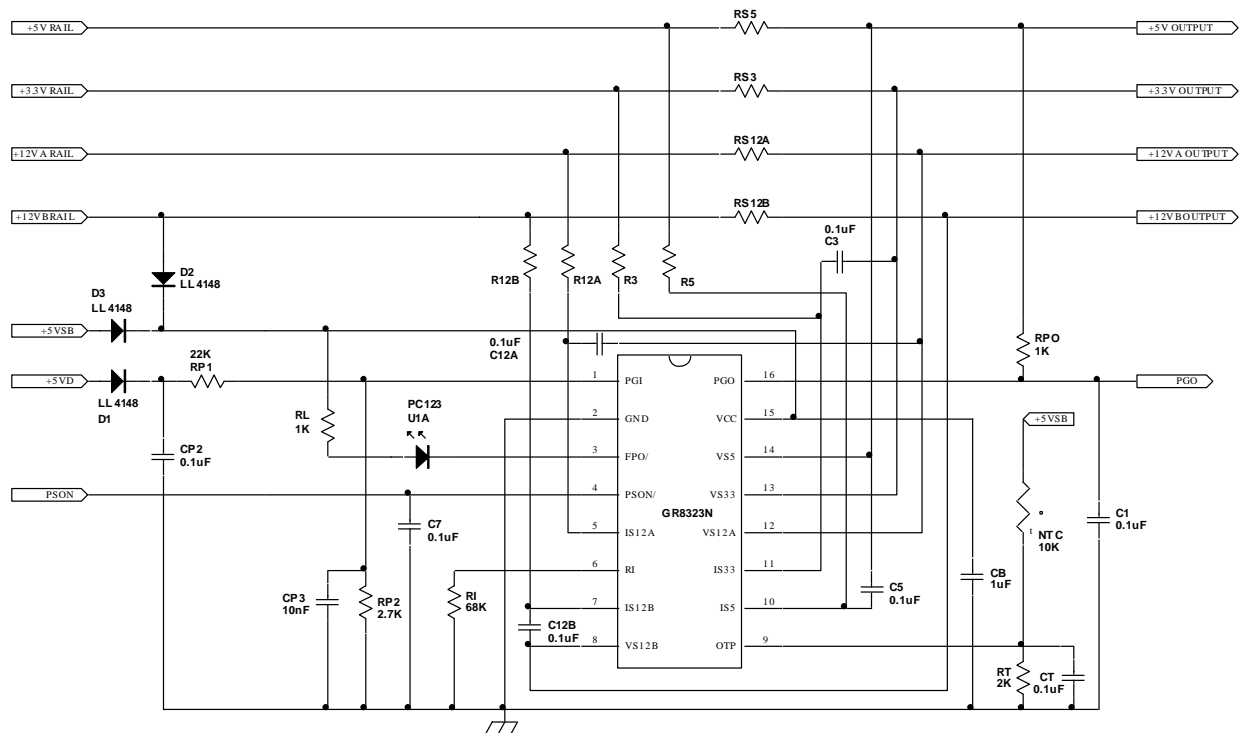

Application Information

1. The GR8323N provides over-current protection (OCP) for the 3.3V, 5V, and two 12V rails. Whenever an OCP condition occurs, the FPO/ output goes high and PGO goes low. Here is an OCP design example:

Suppose the OCP trig point set on 20A,

When OCP occurs, $I_{ocp} * R_s = I_{sink} * R_{oc}$,

Select $R_s = 2m\Omega$, $R_I = 62.5K\Omega$,

Then $I_{sink} = (1.25V/R_I) * 8 = 160\mu A$.

Thus,

$R_{oc} = 20A * 2m\Omega / 160\mu A = 250\Omega$

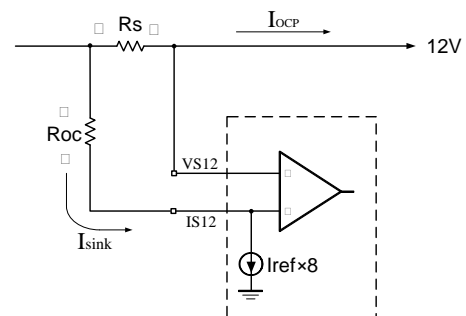

The recommend sense resistor values of RS12A, RS12B, RS5, and RS3 are $\geq 0.002\Omega$ for good accuracy and enough SNR.

2. Over-temperature protection (OTP) design example:
 - (1) NTC resistance: (25°C-10K), (70°C-2.2K)
 - (2) If the OTP trip point is set to 70°C, $V_{OTP} = 2.5V$, $2.5 = V_{cc} * R_T / (R_T + R_{NTC})$, $V_{cc} = 5V$, $R_{NCT} = 2.2K$, so $R_T = 2.2K\Omega$
3. The power supply bypass capacitor CB suggests to be 0.1uF~ 10uF and layout nearby the pin VCC and GND. The other bypass capacitors for OCP or other input and output function pin suggests to be 0.01uF~1uF.

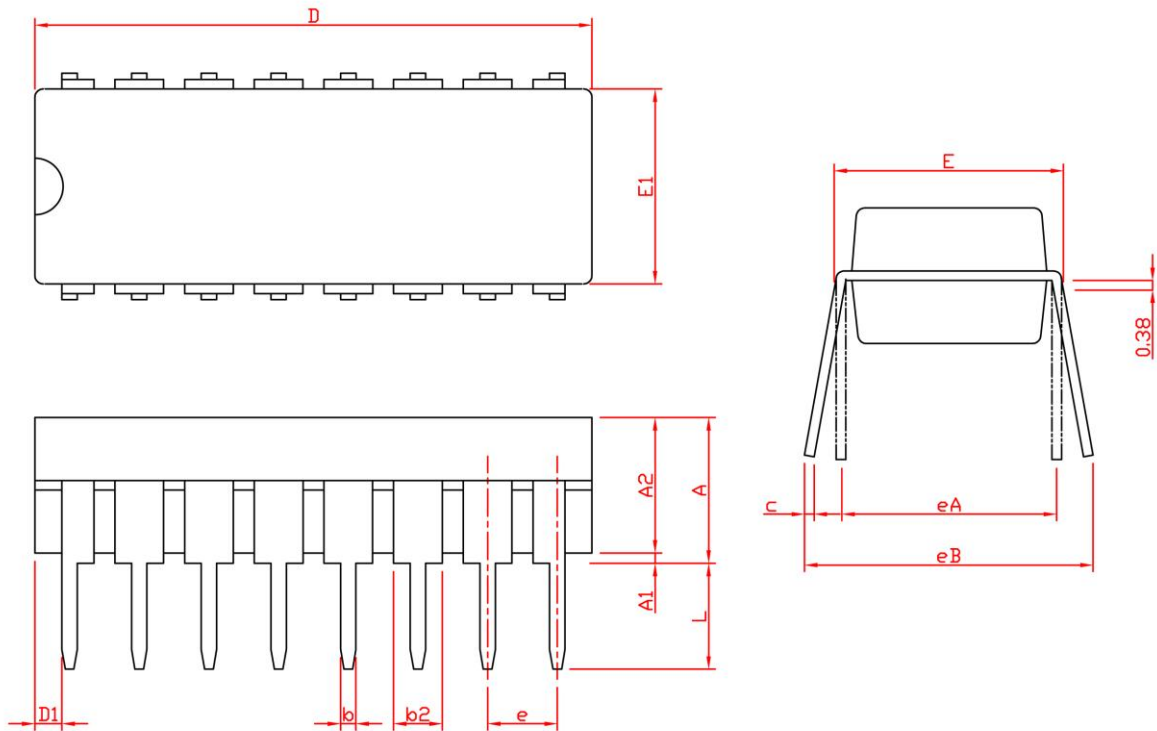
Package Information

SYMBOL	DIP-16			
	MILLIMETERS		INCHES	
	MIN.	MAX.	MIN.	MAX.
A		5.33		0.210
A1	0.38		0.015	
A2	2.92	4.95	0.115	0.195
b	0.36	0.56	0.014	0.022
b2	1.14	1.78	0.045	0.070
c	0.20	0.35	0.008	0.014
D	18.6	20.31	0.732	0.800
D1	0.13		0.005	
E	7.62	8.26	0.300	0.325
E1	6.10	7.11	0.240	0.280
e	2.54 BSC		0.100 BSC	
eA	7.62 BSC		0.300 BSC	
eB		10.92		0.430
L	2.92	3.81	0.115	0.150

Note : 1. Followed from JEDEC MS-001 AB

2. Dimension D, D1 and E1 do not include mold flash or protrusions. Mold flash or protrusions shall not exceed 10 mil.

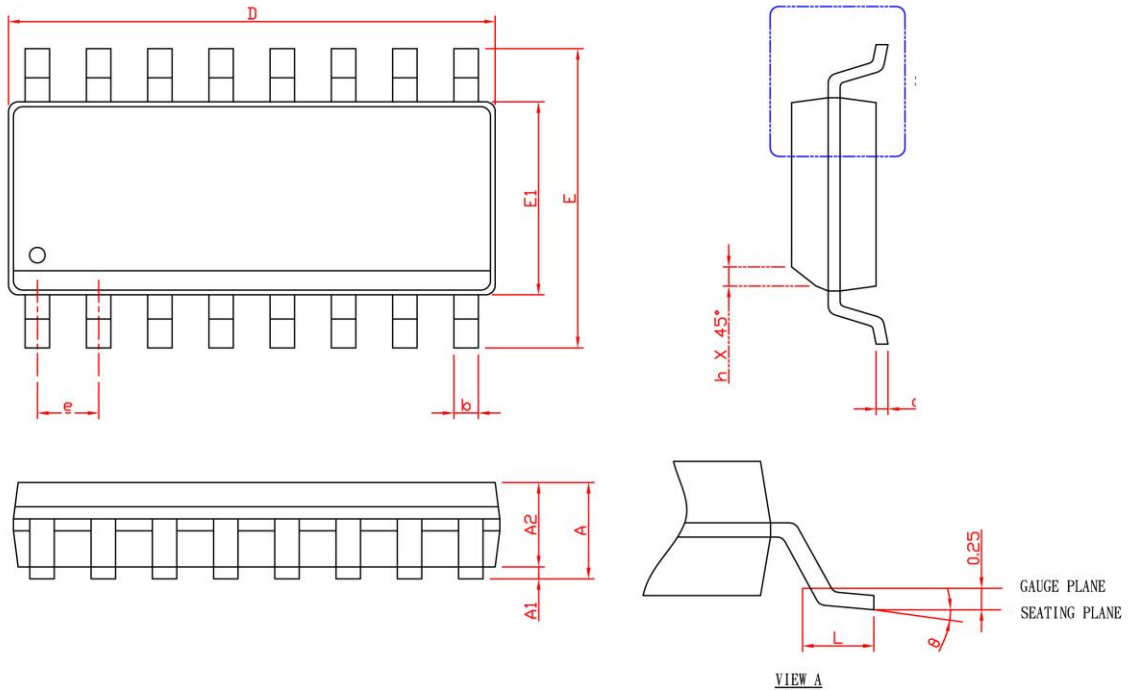
Package Information

SYMBOL	SOP-16			
	MILLIMETERS		INCHES	
	MIN.	MAX.	MIN.	MAX.
A		1.75		0.069
A1	0.10	0.25	0.004	0.010
A2	1.25		0.049	
b	0.31	0.51	0.012	0.020
c	0.17	0.25	0.007	0.010
D	9.80	10.00	0.386	0.394
E	5.80	6.20	0.228	0.244
E1	3.80	4.00	0.150	0.157
e	1.27 BSC		0.050 BSC	
h	0.25	0.50	0.010	0.020
L	0.40	1.27	0.016	0.050
θ	0°	8°	0°	8°

Note: 1. Followed from JEDEC MS-012 AC.

2. Dimension "D" does not include mold flash, protrusions or gate burrs. Mold flash, protrusion or gate burrs shall not exceed 6 mil per side.

3. Dimension "E1" does not include inter-lead flash or protrusions. Inter-lead flash and protrusions shall not exceed 10 mil per side.

Carrier Tape & Reel Dimensions

SOP-16

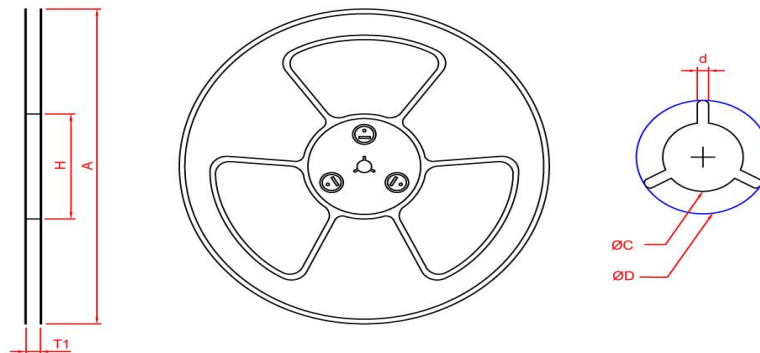
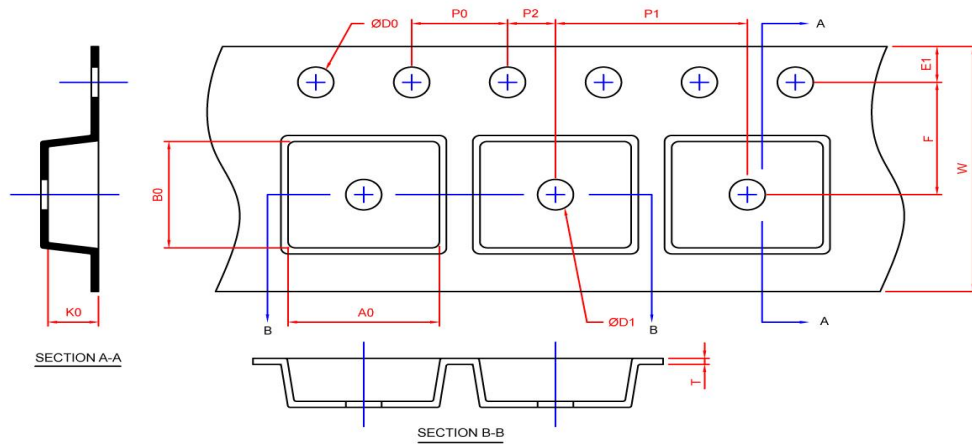

Application	A	H	T1	C	d	D	W	E1	F
SOP-16	330.0±2.0	100 REF	1.4	13.0 + 0.5 - 0.2	2.0±0.5	16.5 REF	16.0±0.2	1.75±0.1	7.5±0.1
	P0	P1	P2	D0	D1	T	A0	B0	K0
	4.0±0.1	8.0±0.1	2.0±0.1	1.5+0.1 -0.0	1.5 MIN.	0.3±0.05	6.5±0.1	10.3±0.1	2.1±0.1

(mm)

Application	Devices Per Reel
SOP-16	2500

Greenergy OPTO, Inc. reserves the right to make corrections, modifications, enhancements, improvements, and other changes to its products and services at any time and to discontinue any product or service without notice. Customers should obtain the latest relevant information before placing orders and should verify that such information is current and complete.

X-ON Electronics

Largest Supplier of Electrical and Electronic Components

Click to view similar products for [Battery Management](#) category:

Click to view products by [Greenergy](#) manufacturer:

Other Similar products are found below :

[MP2602DQ-LF-P](#) [MP26053DQ-LF-Z](#) [MP2611GL-P](#) [NCP347MTAHTBG](#) [LM3658SD-AEV/NOPB](#) [MP2607DL-LF-P](#) [MP26121DQ-LF-P](#)
[MP26123DR-LF-P](#) [MP2633GR-P](#) [MP2637GR-P](#) [BQ24212EVM-678](#) [NCP1855FCCT1G](#) [MP2636GR-P](#) [FAN54063UCX](#)
[MAX14680EWC+T](#) [MAX14634EWC+T](#) [DS2745U+T&R](#) [MAX14578EETE+T](#) [DS2781EVKIT+](#) [DS2781E+T&R](#) [MP2605DQ-LF-P](#)
[DS2710G+T&R](#) [MAX17040G+T](#) [MAX14525ETA+T](#) [MP2615GQ-P](#) [MAX14578EEWC+T](#) [LC05132C01NMTTGTG](#) [MAX8971EWP+T](#)
[MAX14630EZK+T](#) [MAX1873TEEE+T](#) [PSC5415A](#) [AUR9811DGD](#) [SN2040DSQR](#) [DS2715BZ+T&R](#) [MAX1508ZETA+T](#)
[MAX14921ECS+T](#) [MAX77301EWA+T](#) [BD8668GW-E2](#) [MAX16024PTBS+T](#) [DS2715Z+T&R](#) [MAX16024LTBZ18+T](#) [DS2782E+T&R](#)
[DS2782G+T&R](#) [MAX1908ETI+T](#) [ISL95522IRZ](#) [ISL95522HRZ](#) [ARD00558](#) [NCP4371AAEDR2G](#) [BD8665GW-E2](#) [MAX8934EETI+T](#)