

Current Mode PWM Power Switch

Features

- Current Mode PWM
- Very Low Startup Current
- Under-Voltage Lockout (UVLO)
- Non-Audible-Noise Green-Mode Control
- Fixed Switching Frequency of 50KHz
- Cycle-by-Cycle Peak Current Limiting
- Internal Leading-Edge Blanking
- Internal Slope Compensation
- Internal 5mS Soft Start
- VCC Over Voltage Clamp
- Over-Voltage Protection (OVP) on VCC Pin
- Over-Load Protection (OLP)

Applications

- Switching AC/DC Power Battery Charger
- Digital Camera
- Open-Frame SMPS
- PDA Power Supply

Description

GR8935LA integrates a PWM controller and high voltage power MOSFET of 650V. GR8935LA has the features of very low startup current and current mode PWM control with green-mode function at light load. These features enable the power supply to easily meet even the strictest power conservation requirements. The integrated functions of GR8935LA also include the leading-edge blanking of the current sensing, internal slope compensation, cycle-by-cycle peak current limiting and soft start. OCP, OVP and OLP provide protection performance for fault conditions. To protect the power MOSFET from being damaged by supply over voltage, the internal gate voltage of GR8935LA is clamped at 18V.

GR8935LA improves the performance and reduces the cost of power supplies.

Ordering and Marking Information

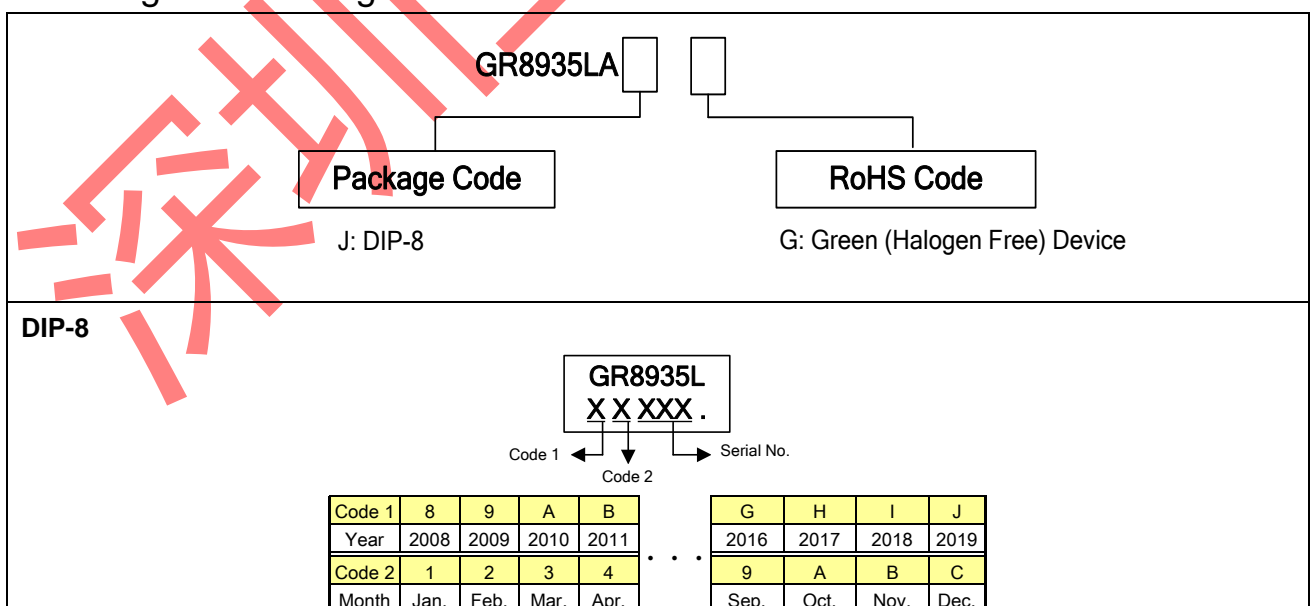

Nanjing Greenchip Semiconductor Co., Ltd. (Grenergy OPTO, Inc.) reserves the right to make changes to improve reliability or manufacture ability without notice, and advise customers to obtain the latest version of relevant information to verify before placing orders.

Pin Configuration

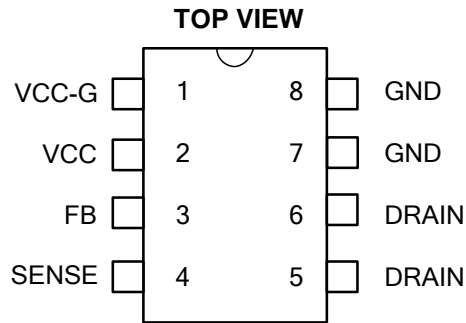

Pin Description

Pin No.	Symbol	Description
1	VCC-G	Power supply input for internal gate driver
2	VCC	Power supply input for IC
3	FB	Voltage feedback pin, by connecting a photo-coupler to control the duty cycle
4	SENSE	Current sense pin
5, 6	DRAIN	Drain of internal HV MOS
7, 8	GND	Ground

Recommended Operating Conditions

Item	Min.	Max.	Unit
Supply voltage VCC	11	25	V
VCC-G pin series resistor	51	510	Ohm
VCC pin series resistor	10	75	Ohm
FB pin capacitor	1	100	nF

Note: 1. FB pin parallel one 6.5V Zener diode for Safety Regulation on abnormal test.

2. Sense pin resistor recommended to use SMD type for avoiding stray inductor interference issue.

Recommended Output Power Range

Part No.	90~264Vac	
	Open frame	Adaptor
GR8935LA	18W	12W

Notes: Maximum practical continuous power output should design with sufficient drain pattern as a heat sink, at 50°C ambient.

Absolute Maximum Ratings

Drain voltage	-----	-0.3V ~ 650V
Supply voltage VCC	-----	30V
VCC-G	-----	30V
FB sense	-----	-0.3 ~ 7V
Max operating junction temperature	-----	150°C
Operating ambient temperature	-----	-20°C ~ 85°C
Storage temperature range	-----	-65°C ~ 150°C
Lead temperature (All Pb free packages, soldering, 10 sec)	-----	260°C
ESD Voltage Protection, Human Body Model	-----	2KV
ESD Voltage Protection, Machine Model	-----	200V

Block Diagram

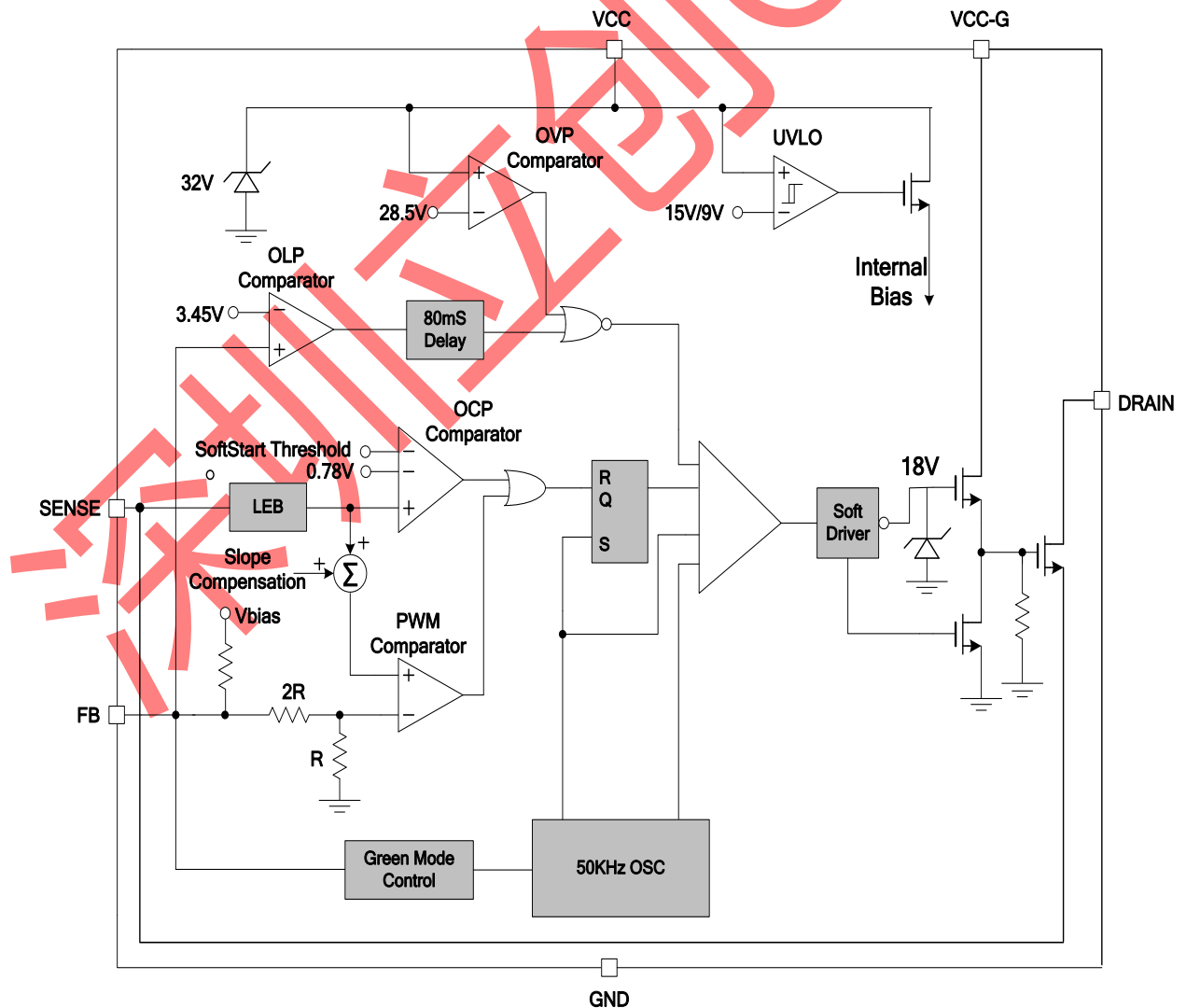

Electrical Characteristics ($T_A = +25^\circ\text{C}$ unless otherwise stated, $V_{CC} = 15.0\text{V}$)

Parameter	Pin	Min.	Typ.	Max.	Unit
SUPPLY VOLTAGE					
Startup Current	2		7	20	μA
Operating Current, $V_{FB} = 2.5\text{V}$	2		2.5		mA
UVLO (off)	2	8.0	9.0	10.0	V
UVLO (on)	2	14.0	15.0	16.5	V
VCC Hyst		4	6		V
OVP Level on VCC Pin	2	27	28.5	30	V
VCC Zener Clamp	2		32		V
VOLTAGE FEEDBACK					
Short Circuit Current, $V_{\text{comp}} = 0\text{V}$	3	1.0	1.5	1.8	mA
Open Loop Voltage, COMP Pin Open	3		5		V
Green-mode threshold voltage	3		1.2		V
CURRENT SENSING					
Minimum Input Voltage at 0% duty	4	0.72	0.78	0.82	V
Leading-Edge Blanking Time	4		350		nS
Input Impedance	4		300		$\text{K}\Omega$
Delay to Output	4		100		nS
OSCILLATOR					
Frequency	-	45	50	55	KHz
Green Mode Frequency		21	25		KHz
Temp. Stability ($-40^\circ\text{C} \sim 110^\circ\text{C}$)	-		5		%
Voltage Stability ($V_{CC} = 11\text{V} \sim 25\text{V}$)	-		3		%
MOSFET SECTION					
V_{ds}	5 & 6		650		V
$R_{ds}(\text{on})$	5 & 6		3.6		Ω
OLP					
OLP Delay Time	-		80		mS
OLP Trim Level	-		3.45		V

Typical Performance Characteristics

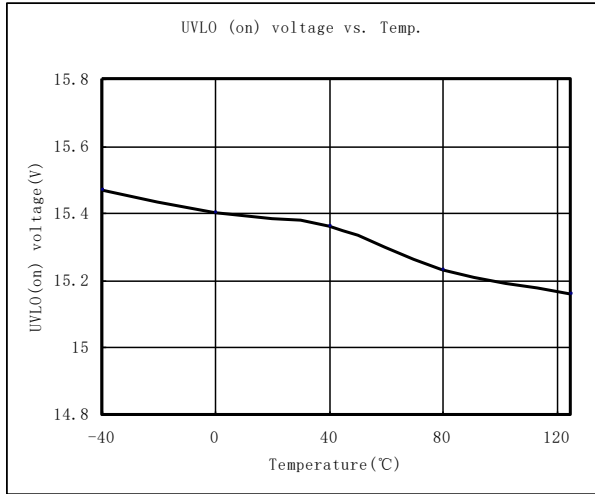
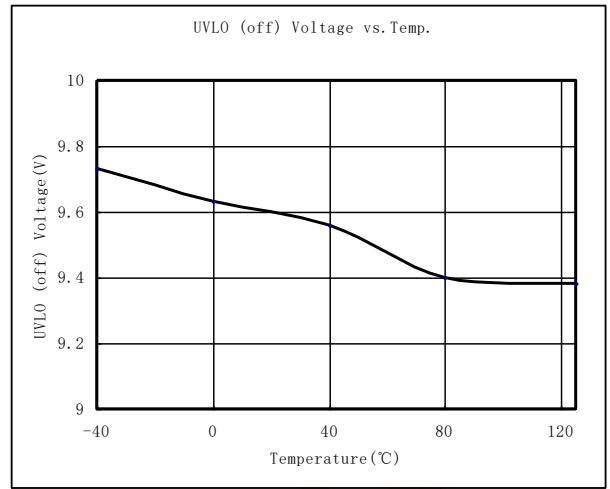
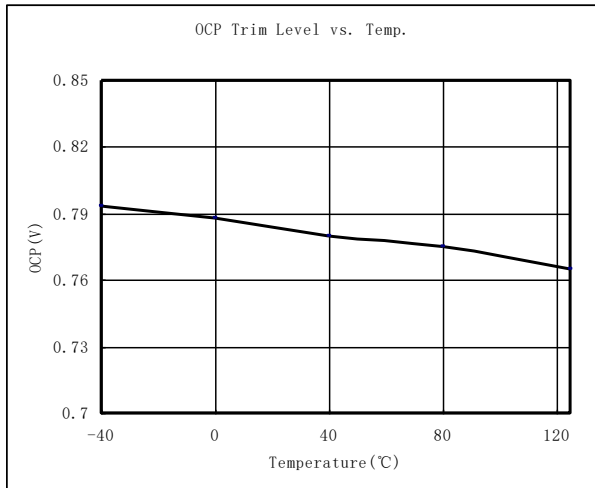
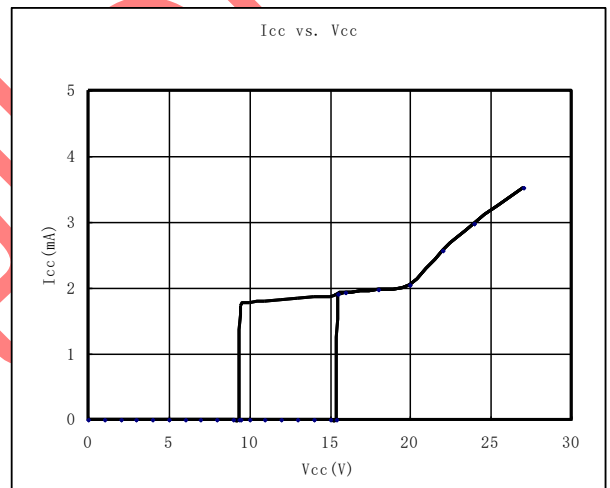
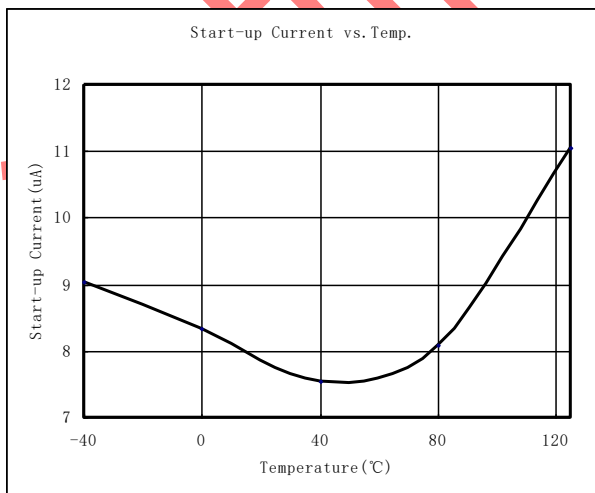
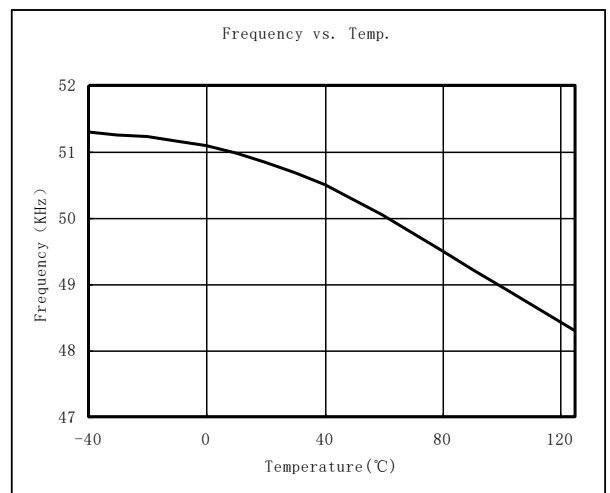
Fig. 1

Fig. 2

Fig. 3

Fig. 4

Fig. 5

Fig. 6

Application Information

Start-up Current

The typical start-up current is 7uA. Very low start-up current allows the PWM controller to increase the value of start-up resistor and then reduce the power dissipation on it.

Under-voltage Lockout (UVLO)

A hysteresis UVLO comparator is implemented in GR8935LA, then the turn-on and turn-off thresholds level are fixed at 15V and 9V respectively. This hysteresis shown in Fig. 7 ensures that the start-up capacitor will be adequate to supply the chip during start-up.

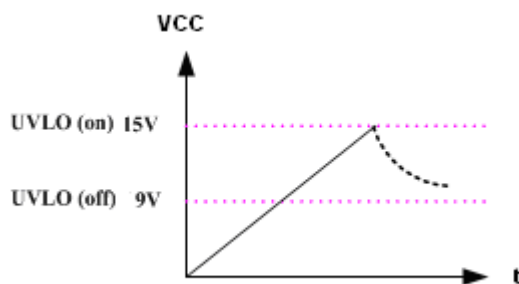

Fig. 7

Soft Start

During initial power on, GR8935LA provides soft start function. It effectively suppresses the start up peak current to reduce the power MOSFET drain voltage especially at high line.

Oscillator

The frequency of the oscillator is fixed internally at about 50kHz. The maximum duty-cycle of internal oscillator is limited about 75% to avoid the transformer saturation.

Green Mode Operation

When the load decreases to an extent, the frequency of the controller will decrease so as to reduce the system power consumption. The

minimum frequency is about 25KHz, which is outside the audio range.

Leading-edge Blanking (LEB)

Each time the power MOSFET is switched on, a turn-on spike will inevitably occur at the sense resistor. To avoid fault trigger, a 350ns leading-edge blanking time is built in. Conventional RC filtering can therefore be omitted. During this blanking period, the current-limit comparator is disabled and can not switch off the gate driver.

Internal Slope Compensation

A built-in slope compensation circuit is constructed in GR8935LA. When the switch is on, a ramp voltage is added to the sensed voltage across the Sense, which helps to stabilize the system and prevent sub-harmonic oscillations.

Over-load Protection (OLP)

The controller has over load protection function. An internal circuit detects the load level, when the load is larger than a threshold and the condition lasts more than 80ms, the gate output will keep low level. Then VCC decreases below UVLO off level, the controller resets again.

Over-voltage Protection (OVP) on VCC

To prevent power MOSFET from being damaged, GR8935LA is implemented an OVP function on VCC. When the VCC voltage is higher than the OVP threshold voltage, the output gate driver circuit will be shut down immediately to stop the switching of internal HV power MOSFET.

The VCC OVP function is an auto-recovery type protection. If OVP happens, the pulses will be stopped and recover at the next UVLO on. GR8935LA is working in a hiccup mode.

Gate Driver

Driving ability can be adjusted by a resistor between VCC and VCC-G for EMI improvement. The resistor can decrease rising time of internal gate driver. But be attention that too large resistance could decrease system efficiency (especially at CCM condition).

仅供内部使用

Typical Application Circuit

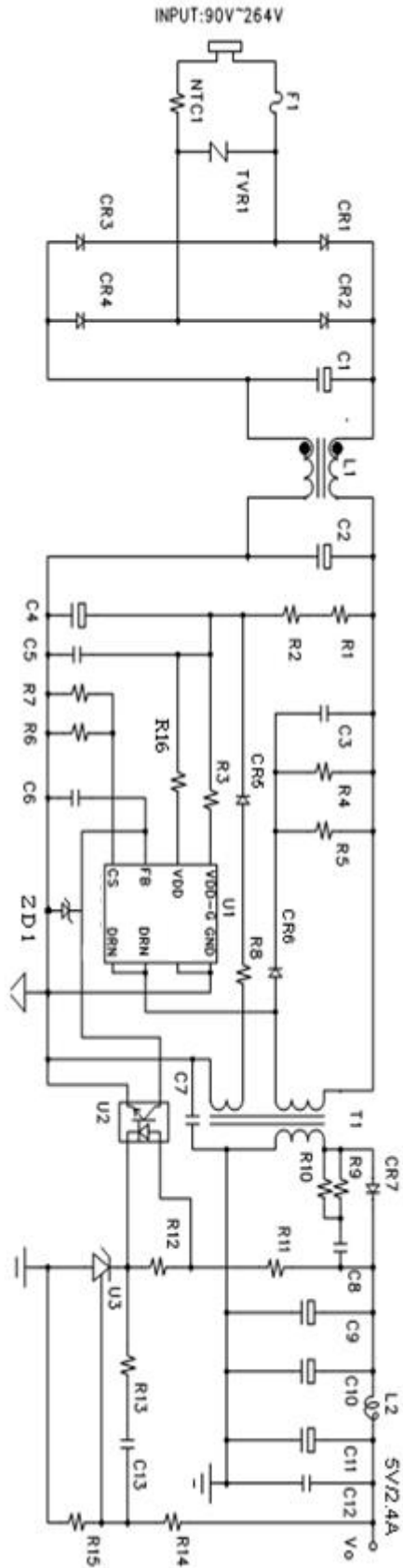

家

ONLY

BOM List

No.	Part.No	Description	Note	No.	Part.No	Description	Note
1	C1	E-CAP 400V/10Uf		25	R1	SMD1206 / 105	
2	C2	E-CAP 400V/10Uf		26	R2	SMD1206 / 514	
3	C3	332/1KV		27	R3	SMD0805/ 511	
4	C4	E-CAP 50V/10Uf		28	R4	SMD1206 / 104	
5	C5	SMD0805,104		29	R5	SMD1206 / 683	
6	C6	10 nF		30	R6	SMD1206 / 2.7R	
7	C7	Y1 CAP 1000pF		31	R7	SMD1206 / 2.2R	
8	C8	SMD0805,222		32	R8	SMD0805 / 0R	
9	C9	E-CAP 10V/1000Uf		33	R9	SMD1206 / 33R	
10	C10	E-CAP 10V/1000Uf		34	R10		N.C
11	C11	E-CAP 16V/330Uf		35	R11	SMD0805/ 221	
12	C12	SMD0805,104		36	R12		N.C
13	C13	SMD0805,104		37	R13	SMD0805 / 202	
14	CR1	1N4007		38	R14	SMD0805 / 472	1%
15	CR2	1N4007		39	R15	SMD0805 / 472	1%
16	CR3	1N4007		40	R16	SMD0805/ 47R	
17	CR4	1N4007		41	J1	Jumper	
18	CR5	FR104		42	J2	SMD1206 / 0R	
19	CR6	FR107		43	T1	EE19	1.77Mh
20	CR7	SR540		44	TVR1		N.C
21	F1	250V/1A		45	U1	GR8935LA	DIP8
22	L1		30Mh	46	U2	EL817	
23	L2	R3*5	1.0Uh	47	U3	GL431	
24	NTC1	5Ω		48	ZD1	6.5V	

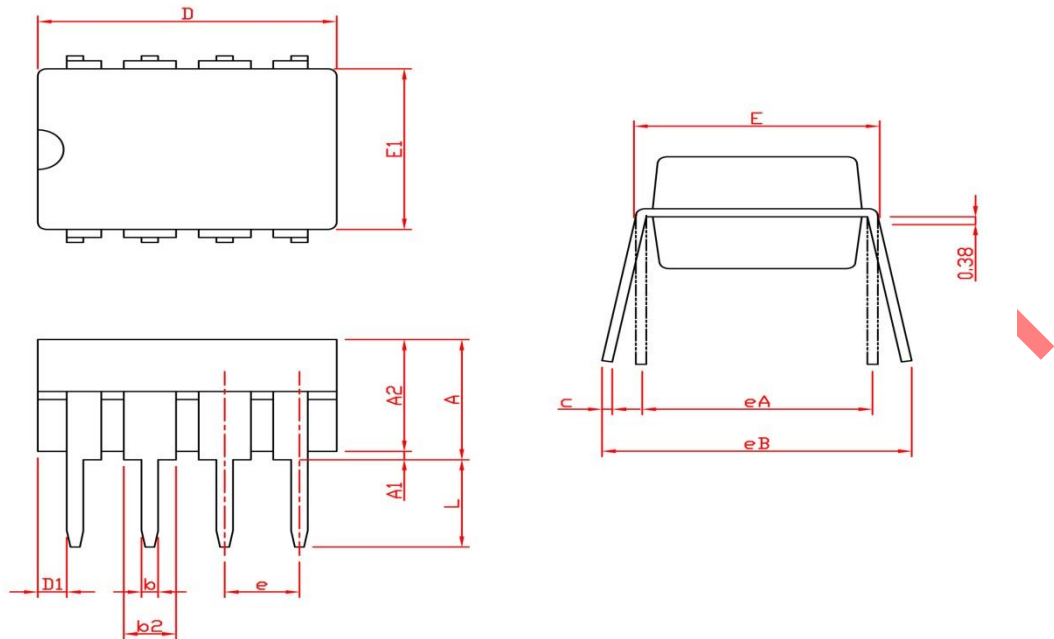
Package Information

SYMBOL	DIP-8			
	MILLIMETERS		INCHES	
	MIN.	MAX.	MIN.	MAX.
A		5.33		0.210
A1	0.38		0.015	
A2	2.92	4.95	0.115	0.195
b	0.36	0.56	0.014	0.022
b2	1.14	1.78	0.045	0.070
c	0.20	0.35	0.008	0.014
D	9.01	10.16	0.355	0.400
D1	0.13		0.005	
E	7.62	8.26	0.300	0.325
E1	6.10	7.11	0.240	0.280
e	2.54 BSC		0.100 BSC	
Ea	7.62 BSC		0.300 BSC	
Eb		10.92		0.430
L	2.92	3.81	0.115	0.150

Note: 1. Followed from JEDEC MS-001 BA.

2. Dimension D, D1 and E1 do not include mold flash or protrusions. Mold flash or protrusions shall not exceed 10 mil.

Nanjing Greenchip Semiconductor Co., Ltd. (Grenergy OPTO, Inc.) reserves the right to make corrections, modifications, enhancements, improvements, and other changes to its products and services at any time and to discontinue any product or service without notice. Customers should obtain the latest relevant information before placing orders and should verify that such information is current and complete.

X-ON Electronics

Largest Supplier of Electrical and Electronic Components

Click to view similar products for [Switching Voltage Regulators](#) category:

Click to view products by [Greenergy](#) manufacturer:

Other Similar products are found below :

[FAN53610AUC33X](#) [FAN53611AUC123X](#) [MP2374DS-LF-Z](#) [AP3602AKTR-G1](#) [NCP81108MNTXG](#) [NCP81109BMNTXG](#)
[FAN48610BUC45X](#) [FAN48617UC50X](#) [R3](#) [430464BB](#) [FAN53611AUC12X](#) [MAX809TTR](#) [NCV891234MW50R2G](#) [AST1S31PUR](#)
[NCP81103MNTXG](#) [NCP81203PMNTXG](#) [NCP81208MNTXG](#) [NCP81109GMNTXG](#) [SCY1751FCCT1G](#) [NCP81109JMNTXG](#)
[NCP81241MNTXG](#) [MP2388GQEU-Z](#) [MPQ4481GU-AEC1-P](#) [MPQ2171GJ-P](#) [IR3888MTRPBFAUMA1](#) [MPQ2171GJ-AEC1-P](#) [MP2171GJ-](#)
[P](#) [NCV1077CSTBT3G](#) [MP28160GC-Z](#) [LTM4691EV#PBF](#) [XCL207A123CR-G](#) [XDPE132G5CG000XUMA1](#) [XDPE12284C0000XUMA1](#)
[LTM4691IV#PBF](#) [MP5461GC-P](#) [MIC23356YFT-TR](#) [ISL95338IRTZ](#) [TPS55162QPWPRQ1](#) [MP3416GJ-P](#) [BD9S201NUX-CE2](#)
[ISL9113AIRAZ-T](#) [MP5461GC-Z](#) [MPQ2172GJ-AEC1-Z](#) [MPQ4415AGQB-Z](#) [MPQ4590GS-Z](#) [FAN53526UC224X](#) [S-19903DA-A8T1U7](#) [S-](#)
[19903CA-A6T8U7](#) [S-19915BA-A8T1U7](#) [S-19903CA-S8T1U7](#)