

1140-DB-A

DIRECT BOX TRANSFORMER
12:1 TURNS RATIO WITH DUAL SHIELDS

This transformer provides balanced microphone output signal from an unbalanced line level signal. This is ideal for feeding long cables with minimal high frequency losses.

It also has excellent shielding from the mu metal can.

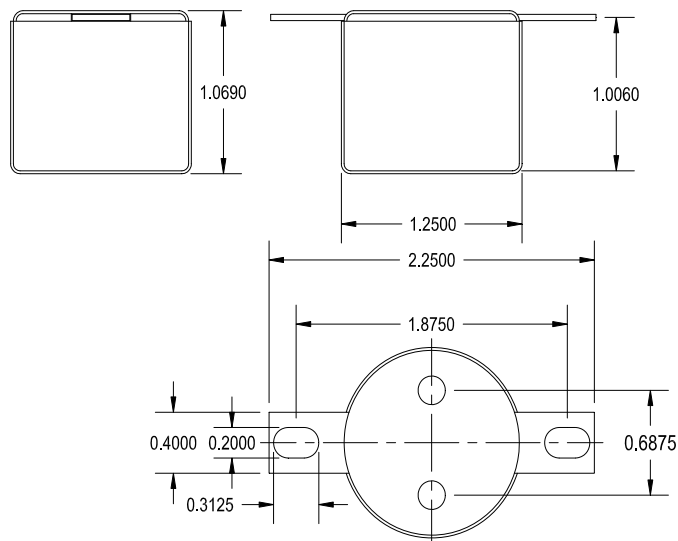

ELECTRICAL SPECIFICATIONS

Characteristic	Conditions	Typical
Input Impedance		200000 Ω
Output Impedance		1500 Ω
Primary Input Impedance	@ 1kHz -20dbu Test Circuit 3	140KΩ
Secondary Output Impedance	@ 1kHz -20dbu Test Circuit 4	150Ω
Maximum input Level	@ 20Hz RL = 600Ω	+21.0db
DCR		
Primary	@20°C	4.25 KΩ
Secondary	@20°C	72.0 Ω
Frequency Response	@ 20 Hz, -20 dbu, Test Circuit 3	-0.07db
	@ 20 kHz, -20 dbu, Test Circuit 3	-0.06db
Turns ratio		11.54:1
Common Mode Rejection Level	@ 60 Hz Test Circuit 2	70db
	3kHz Test Circuit 2	60db
THD	@ 1kHz -20 dbu Test Circuit 1	0.025%
	@ 20Hz -20 dbu Test Circuit 1	0.0025%
Phase Shift	@ 20 Hz Test Circuit 1	2.25°
	@ 20 kHz Test Circuit 1	-10.0°
Capacitance	Primary to Shield and Case	550pf
	Secondary to Shield and Case	480pf
Dielectric Strength		500 Vrms



1140-DB-A

PRI:BRN - ORG: 200000 Ω GRY: SHIELD
SEC:GRN - GRN/YEL: 1500 Ω GRY/WHT: SHIELD

CAN GROUND: VIO
MADE IN CANADA DATE

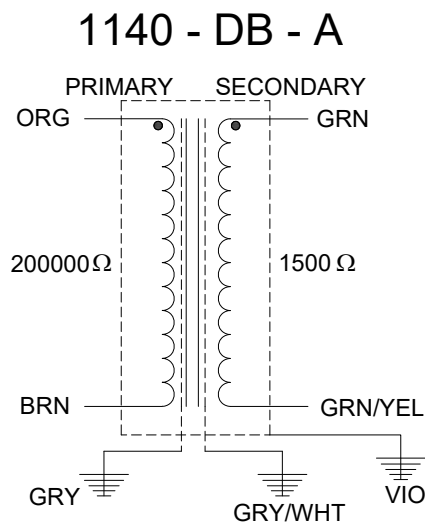

1140-DB-A FREQUENCY RESPONSE

Input Level +4 dbu
Rs = 6800Ω, RL = 1000Ω

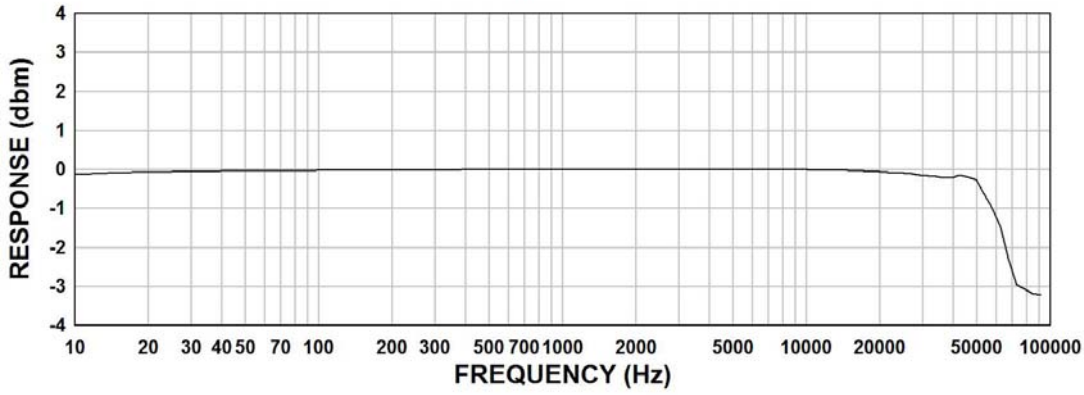

1140-DB-A Phase Shift

Input Level +4 dbu
Rs = 6800Ω, RL = 1000Ω

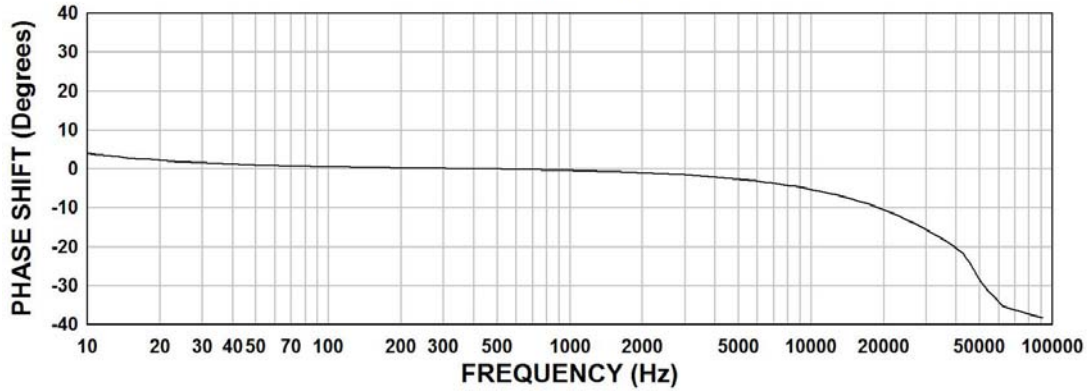

1140-DB-A THD+N

Input Level +4 dbu
Rs = 6800Ω, RL = 1000Ω

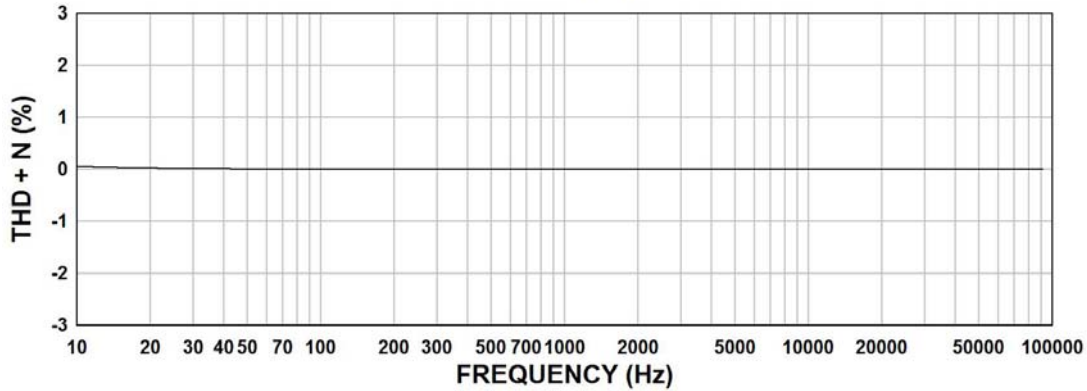

TYPICAL TEST CIRCUIT

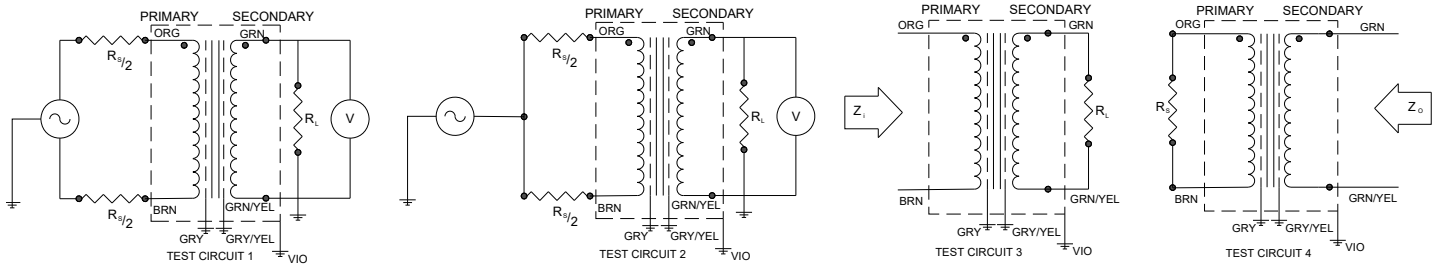

Measurement instruments: Hp4192a Impedance Analyzer; Hp3456a DVM; Keithley 2002 DVM; D scope series iii audio analyzer

This drawing and the information in it is the property of Hammond Manufacturing. It may not be reproduced, transmitted or used in any manner whatsoever without the written permission of Hammond Manufacturing. Data subject to change without notice.

X-ON Electronics

Largest Supplier of Electrical and Electronic Components

Click to view similar products for [Audio Transformers](#) / [Signal Transformers](#) category:

Click to view products by [Hammond](#) manufacturer:

Other Similar products are found below :

[CX2041NLT](#) [MGPWT-00449-P](#) [PE-64961](#) [H1302FNLT](#) [H5008FNL](#) [H5012FNL](#) [H5020FNLT](#) [H5077NLT](#) [H5084FNLT](#)
[B78476A9558A003](#) [1812WBT2-4](#) [1879479-1](#) [HX2260FNL](#) [HX5014FNL](#) [EX2024FNL](#) [FL1066](#) [T1137NLT](#) [T3012NL](#) [PE-65812FNL](#) [PE-65848FNLT](#) [H1174FNL](#) [H1302FNL](#) [H5015FNL](#) [H5019EFNL](#) [H5062FNLT](#) [CX2047LNL](#) [MGPWT-00059-P](#) [MGPWT-00266-P](#) [MGPWT-00278-P](#) [MGPWT-00431-P](#) [TTC-100](#) [TTC-143-H](#) [TTC-5032-1](#) [BX1194WNLT](#) [HX1234NLT](#) [HX5008FNLT](#) [HX5019FNL](#) [HX5084NL](#) [3-1879385-5](#) [TX1263NLT](#) [4-1879391-0](#) [P2004NLT](#) [T1142NL](#) [HX6101FNL](#) [HX1148NL](#) [HX5020FNLT](#) [HX5014FNLT](#) [T1124NL](#) [1879732-1](#)
[2-1879391-5](#)