

产品参数/Product parameters

额定电流 (Rated current): 50mA @ 12 VDC

寿命实验 (Life Test): 100,000 cycles typical

接触电阻 (Contact Resistance): 100MΩ max.

绝缘电阻 (Insulation Resistance): 100MΩ min.

按键行程 (Key stroke): 0.15±0.1mm

驱动力 (Actuation Force): 100gf, 160gf, 260gf

工作温度 (Operating Temperature): -20° C to 70° C

介电强度 (Dielectric Strength): AC 250V 50HZ 1 minute

存储温度 (Storage Temperature): -30° C T0+80° C

最小包装 (Minimum package): 3000PCS (卷装)

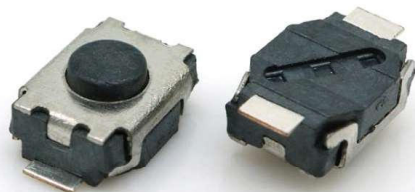

产品名称 Product name

- ▶ 3*4 二脚贴片小龟
- ▶ 3 * 4 two foot patch turtle

产品应用场景 Product application scenario

- ▶ 电子通讯/数码产品/家用电器
- ▶ 外围设备/汽车/医疗设备等.
- ▶ Electronic communication/digital products/household appliance peripherals/AuTomotive/medical equipment, etc

材质/MATERIALS:

| No. | 名称 NAME | 材料 MATERIAL | 表面处理/颜色 Surface treatment/color |
|-----|-------------------|----------------|------------------------------------|
| ① | 按钮 Button | LCP | 黑色 Black |
| ② | 盖板 Cover plate | F. Ag/SUS | 镀镍 NICKel plated |
| ③ | 基座 Base | LCP | 黑色 Black |
| ④ | 弹片 Shrapnel | F. Ag/SUS | 镀银 Plate with silver |
| ⑤ | 端子 Terminal | Brass | 镀银 Plate with silver |

产品高度/Product height:

| 产品高度 (Product height) | |
|-----------------------|-----|
| Code | H |
| 20 | 2.0 |
| 25 | 2.5 |
| 30 | 3.0 |
| | |
| | |

产品编号/Product No

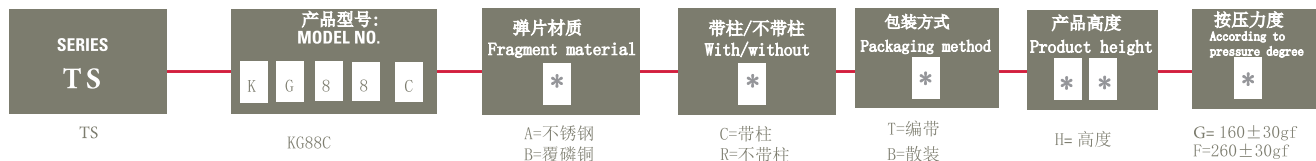

产品订购号示意图/Schematic diagram of product order number

Schematic diagram of product order number: TS-KG88C-ACT20F

产品外形尺寸图/Outline dimension drawing of product

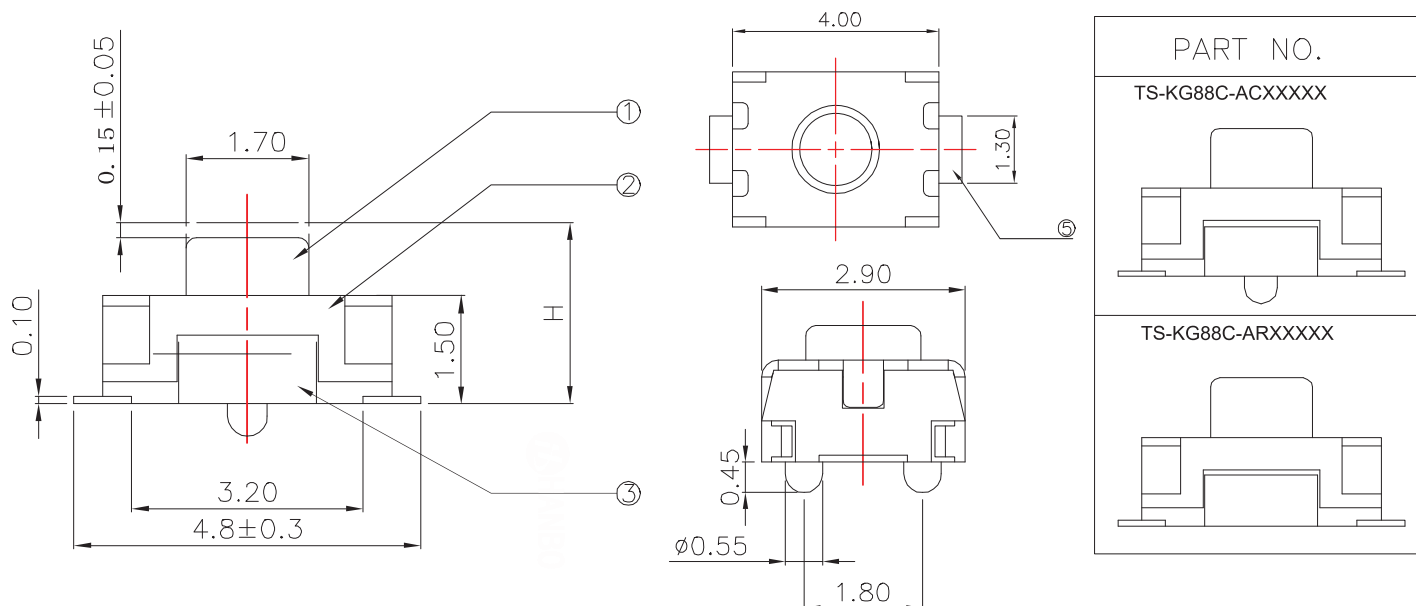

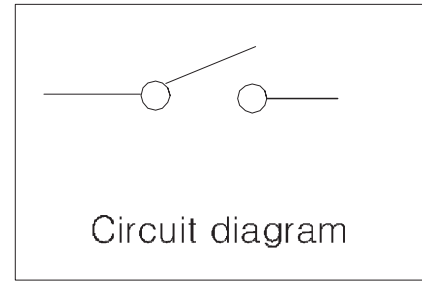
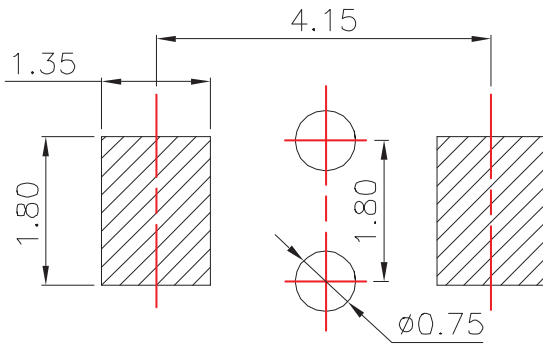

PCB Layout

▶ ▶ ▶ 焊接条件/Welding conditions

■ 回流焊时/During reflow soldering

适用于表面贴装型温度分布/Applicable to surface mount temperature distribution

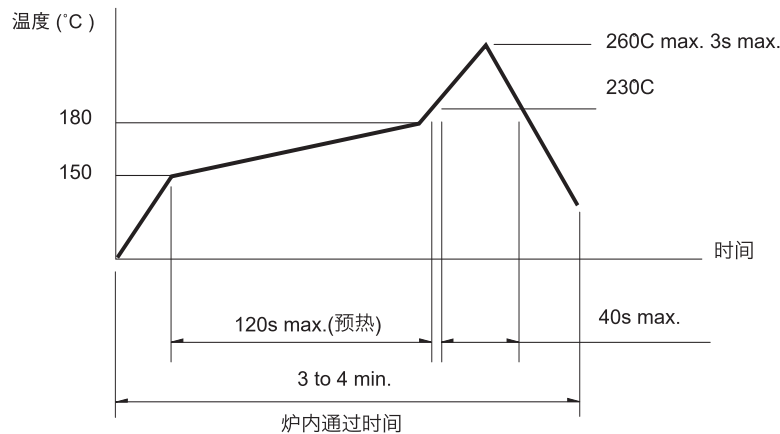

注/notes

- 关于详细条件，请于本公司的产品规格书进行确认。
Please confirm the detailed conditions in our product specification
- 根据贴面焊槽的种类，条件不同结果不同，请事先充分进行确认之后使用。
According to the type of veneer welding groove and different conditions, the results are different. Please fully confirm before using.

■ 自动浸焊式/Automatic dip welding

| 项目 | 条件 |
|--------|--------------------------|
| 助焊剂附着量 | 不附着于零部件贴装面的程度 |
| 预热温度 | 印刷电路板焊接面的周围温度 100°C max. |
| 预热温度时间 | 60s max. |
| 焊接温度 | 260°C max. |
| 焊接浸渍时间 | 5s max. |
| 焊接次数 | 2 times max. |

注/notes

- 请不要从轻触开关上面浸入助焊剂。
Do not immerse the flux on the touch switch
- 请不要事前在开关端子及印刷电路板的零部件贴装面上涂助焊剂。
Please do not apply flux on the mounting surface of switch terminals and printed circuit board components in advance
- 进行第 2 次焊接时，应在开关回复到常温之后进行。
The second welding shall be carried out after the switch returns to normal temperature.

■ 手焊式/Hand welded

| 项目 | 条件 |
|--------|------------|
| 焊接温度 | 350°C max. |
| 焊接浸渍时间 | 3s max. |
| 焊剂斗容量 | 60W max. |

X-ON Electronics

Largest Supplier of Electrical and Electronic Components

Click to view similar products for [Tactile Switches](#) category:

Click to view products by [Hanbo Electronic](#) manufacturer:

Other Similar products are found below :

[5GTH92001](#) [5GTH9202242](#) [ADTSA62NV](#) [ADTSA62RV](#) [B3F-3123](#) [1977177-8](#) [1977266-1](#) [ADTSA63NV](#) [ADTSM21NSVTR](#)
[ADTSM25RVTR](#) [ADTSM32NVTR](#) [ADTSMW64RV](#) [FSMRA4JHA04](#) [GS4.70F300QP](#) [3ESH9R](#) [KSC241J](#) [SP DELTA LFS](#) [3FTL600RAS](#)
[3FTL640RAS](#) [Y96K132V0FPLFS](#) [5GSH92001](#) [5GTH9658222](#) [ADTSM31NVTR](#) [2-1977120-7](#) [TSJW-5.2-260-TR](#) [KMT011MNGJLHS](#)
[ADTSG648NV](#) [ADTSM62KSVTR](#) [ADTSM648NV](#) [95C06E3RAT](#) [3ATH9Q](#) [FSM4JSMLXTR](#) [FSM4JSMXL](#) [FSMRA8JHA04](#) [HARS0073](#)
[Y97HS12A5RAFP](#) [Y97BT23B2HAFP](#) [Y33R411N9FPLFT](#) [Y31C01402FPLFS](#) [PTS645SK50SMTR92](#) [ADTSM32NVB](#) [KMS233GPWTLFG](#)
[Y78B42324FP](#) [Y33R21116FPLFT](#) [Y31B43131FPLFG](#) [Y78B64124FP](#) [Y71243251FP](#) [Y33R31119FPLFT](#) [Y97HS12A5TAFP](#)
[PTS638SK25SMTR2LFS](#) [Y97LT25BADBFP](#)