

锁定功能	无锁	
	手柄/按钮	PDM
名称及材料	盖板	PC
	基座	PA66
	针脚	H62(镀银)
	钩	精密钢丝
	弹簧	碳素钢
	接触夹	覆合银铜皮
电路图	<p>PUSH OFF: 1-2, 4-5 通 PUSH ON: 2-3, 5-6 通</p>	
印刷板开孔尺寸		
货号		
名称	HX 8.5-8.5 WS	
图号		
页码	总页数	

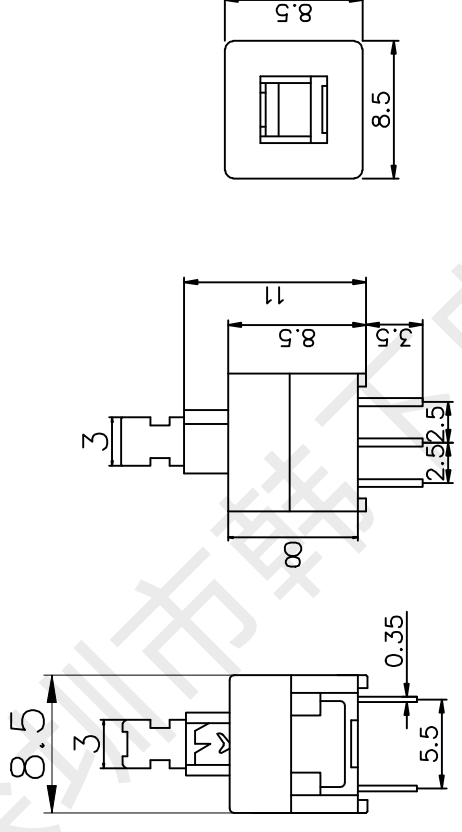

1: SPECIFICATION

- 1、Rating: DC 30V 0.1A
- 2、Contact resistance: $\leq 100m\Omega$
- 3、Insulation resistance: $\geq 100M\Omega$ DC500V
- 4、Withstand voltage: AC 300V(30Hz)/min
- 5、Insertion and extraction force: $180 \pm 30gf$
- 6、life test: 5000 cycles

2: Did not note the size busstrip:

- 1.0-10.0mm $\pm 0.10mm$
- 10.0-20.0mm $\pm 0.20mm$
- 20.0-50.0mm $\pm 0.25mm$

深圳市韩下电子有限公司
 HANXIA

签字	批准	罗小春
绘图	审核	张伟
比例	日期	2022.1.11
1:1		



深圳市韩下电子有限公司

Shenzhen Hanxia Electronic Co., Ltd
Tel: 0755-33819206 Fax: 0755-27597491

承 认 书

SPECIFICATION FOR APPROVAL

客 户 Customer:

产品名称 Project:

自锁开关

规格型号 Part No:

HX 8.5-8.5 WS

贵公司承认印 Approval signatures

料 号/Part No.	签 章/Signatures

日期 Date:

拟制/Drawn	黄彬	
审核/Check	张伟	
批准/Approved	罗小春	

1. 一般特性 General Characteristics

- 1.1 额定值(Rating Value): DC30V/0.1A
- 1.2 工作温度(Work Temperature Range): $-10^{\circ}\text{C} \sim 70^{\circ}\text{C}$
- 1.3 存贮温度(Store Temperature Range): $-20^{\circ}\text{C} \sim 80^{\circ}\text{C}$
- 1.4 正常测试条件(未有特殊说明量测在以下条件进行):

General test condition (Tests and measurements shall be made under the following standard conditions unless otherwise specified):

正常温度: $5^{\circ}\text{C} \sim 35^{\circ}\text{C}$ 相对湿度: 45%~85% RH 气压: 8,600~10,600 帕
 Temperature: $5^{\circ}\text{C} \sim 35^{\circ}\text{C}$ Relative humidity: 45%~85% Air pressure: 8,600~10,600 pa

2. 产品外观及尺寸要求 Appearance & Dimension Requirement

- 2.1 产品外形结构紧凑, 无配合不良.
The structure of product is compact, and assembly of parts has no badness.
- 2.2 产品塑胶部件无严重缩水、披锋、欠注、斑点、破损或变形现象.
The plastic parts of product have no serious defects such as very serious shrink, scarcity, fleck, disrepair, transmutation, etc.
- 2.3 产品引脚和外壳无严重氧化、脏污、变形、毛刺或电镀不良.
Lead feet and shell have no serious defects such as oxidation, smudge, disrepair, burr, defects on plating.
- 2.4 开关操作顺畅, 节奏感强, 无明显卡塞现象.
Operating switch is unhindered, rhythmmed, and there is not palpable clag.
- 2.5 产品结构及尺寸参见产品规格图纸.
Construction and dimensions: Refer to individual product drawing.

3. 电气特性 Electronic Characteristics

No.	项 目 Item	测试方法 Test Method	测试设备 Equipment	特性要求 Requirements
3.1	接触电阻 Contact Resistance	在低电流 ($\leq 100\text{mA}$) 条件下测试. Measured at low current (100mA or less).	低电阻测试仪 Low Resistance Meter	$100\text{m}\Omega$ max
3.2	绝缘阻抗 Insulation Resistance	测试相邻引脚之间, 引脚与外壳之间的绝缘阻抗(DC 500V). Measurement shall be made between adjacent terminals, between terminal and shell(DC 500V).	绝缘测试机 Insulation Resistance Tester	$100\text{M}\Omega$ min
3.3	耐压测试 Dielectric Withstand Voltage	输入一定电压(30Hz, 电压值 AC 300V)1 分钟, 漏电流为 2mA, 测试邻近端子间. Apply certain voltage (30Hz, AC 300V) for 1 minute between adjacent contacts of the connector with 2mA leakage sensitivity.	耐压测试机 Puncture Tester	没有绝缘破坏. 电弧等异常. No arcing, break down and damaging insulation.

4. 机械特性 Mechanical Characteristics

No.	项 目 Item	测试方法 Test Method	测试设备 Equipment	特性要求 Requirements
4.1	操作力 Operation Force	<p>逐渐施力操作开关按键，测量开关到达全部工作行程时所需的最大操作力度。</p> <p>Operate the keystroke of the switch and then increase press strength gradually, Measured maximum operation force while the travel of the switch is full.</p>	<p>测力计</p> <p>Force Gauge</p>	180gf ± 30gf
4.2	行 程 Full travel	<p>垂直操作开关按键，量测开关顶端最大移动距离。</p> <p>Operate the keystroke of the switch vertically, the travel distance of keystroke moving from its free position to maximum moving distance shall be measurement.</p>	<p>游标卡尺</p> <p>Vernier Caliper</p>	2.4 ± 0.15mm

5. 可靠性测试 Reliability trial

No.	项 目 Item	测试方法 Test Method	测试设备 Equipment	特性要求 Requirements
5.1	可焊性试验 Solder ability Test	<p>端子顶部被浸入焊锡炉中，温度为 230 ± 5℃，时间 5 ± 1 秒。</p> <p>The top of the terminals shall be dipped in the solder bath at 230 ± 5℃ for 5 ± 1 seconds.</p>	<p>控温锡炉</p> <p>Solder Stove</p>	<p>引脚至少 95% 上锡。</p> <p>Ninety-five percent of terminals shall be dipped.</p>
5.2	寿命试验 Operation Life	<p>开关在寿命试验设备上以约 90 次 / 分的速度连续被操作，具体次数见规格图示。</p> <p>Switch shall be operated continuously at about 90 cycles /min without load.</p>	<p>寿命试验机</p> <p>Life Tester</p>	<p>寿命：5000 次</p> <p>实验后：</p> <p>绝缘电阻：10MΩ Min</p> <p>操作力：变化在 ± 50% 内</p> <p>开关外观及结构无损坏。</p> <p>Life test: 5000 cycles</p> <p>After test:</p> <p>Insulation resistance: 10MΩ Min</p> <p>Operating force: Change should be within ± 50% of specified value.</p> <p>No abnormalities shall be recognized in appearance and construction.</p>

5. 可靠性测试 Reliability trial

No.	项目 Item	测试方法 Test Method	测试设备 Equipment	特性要求 Requirements
5.3	耐焊接热 Resistance to Soldering heat	端子焊接部分浸入焊炉，焊炉温度 $260 \pm 5^\circ\text{C}$ ，焊接时间 5 ± 1 秒。（焊接时不可于端子施加外力）。 Terminals shall be dipped in the solder bath at $260 \pm 5^\circ\text{C}$ for 5 ± 1 seconds without additional force for terminals.	控温锡炉 Solder Stove	本体无变形，能满足于机械、电气性能。 Appearance should be not damaged, electrical and mechanical characteristics shall be satisfied.
5.4	耐高温测试 Resistance to Heat Test	放置在温度 $80 \pm 2^\circ\text{C}$ 环境中 96 小时后，再置于正常条件下 1 小时后测定。 The switch shall be stored at a temperature of $80 \pm 2^\circ\text{C}$ for 96 hours, Measurements shall be made after it be subjected to the standard conditions for 1 hour.	高低温 试验机 High & Low Temperature Tester	外观，机械及电气性能均符合要求。 Appearance, electrical and mechanical characteristics shall be satisfied.
5.5	耐低温测试 Resistance to Cold Test	放置在温度 $-25 \pm 2^\circ\text{C}$ 环境中 96 小时后，再置于正常条件下 1 小时后测定。 The switch shall be stored at a temperature of $-25 \pm 2^\circ\text{C}$ for 96 hours, Measurements shall be made after it be subjected to the standard conditions for 1 hour.	高低温 试验机 High & Low Temperature Tester	外观，机械及电气性能均符合要求。 Appearance, electrical and mechanical characteristics shall be satisfied.
5.6	耐湿性测试 Resistance to Humidity Test	放置于温度 $40 \pm 2^\circ\text{C}$ ，相对湿度为 90~96% 环境中 96 小时后，再置于正常条件下 1 小时后测定（注意要擦去水滴）。 The switch shall be stored at a temperature of $40 \pm 2^\circ\text{C}$, relative humidity 90~96% for 96 hours, Measurements shall be made after it be subjected to the standard conditions for 1 hour (Wipe out water drip).	恒温恒湿箱 Temperature & Humidity Tester Chamber	外观，机械及电气性能均符合要求。 Appearance, electrical and mechanical characteristics shall be satisfied.
5.7	盐雾实验 Salt Mist Test	试件在下述实验后测量： 1. 温度： $35 \pm 5^\circ\text{C}$ 2. 盐溶液浓度： $5 \pm 1\%$ （质量百分比）， 3. 试验时间： 24 小时， 4. 试验后，将盐沉积物用水冲掉。 The switch shall be checked after following test: 1. Temperature: $35 \pm 5^\circ\text{C}$ 2. Salt solution: $5 \pm 1\%$ (Solids by mass) 3. Duration: 24 hours, 4. After immersing, salt deposit shall be removed by running water.	盐雾 试验机 Salt Spray Tester	在金属件上没有严重腐蚀斑点。 No remarkable corrosion shall be recognized in metal parts.

X-ON Electronics

Largest Supplier of Electrical and Electronic Components

Click to view similar products for [Pushbutton Switches](#) category:

Click to view products by [hanxia](#) manufacturer:

Other Similar products are found below :

[8971K1133](#) [LW2L-M1C20M-A](#) [01-153.025](#) [M22-D-R-GB0/K11](#) [67021K512](#) [701PB580](#) [7199K101](#) [810K12910](#) [810KSV30B](#) [FLT 2U EE](#)
[01A](#) [MML21EA2ADK](#) [MML21KA3ABK](#) [MML23KW3AA01W](#) [8418K2](#) [8442K3](#) [8450K1](#) [860K11911T01A](#) [861901](#) [861K11911T01A07](#)
[861K13810T00A14](#) [861K13911](#) [8646AB6X718UL](#) [9533CD4+U574+U4922](#) [99-450.837](#) [99-453.837](#) [A2PMA1X03EC56](#) [A3A-7310](#) [A3A-](#)
[7340](#) [12037A2ULCSA](#) [1203A2UL](#) [ABGW410-R](#) [1211390004](#) [ABN400-R](#) [121382](#) [1213C3](#) [HE3B-M2](#) [1211500044](#) [121194](#) [1212MRA](#)
[1232A6NF](#) [121489](#) [1223A2ULCSA](#) [D5P-MT4](#) [13435AG](#) [13445AD29GX768](#) [AG23-L2](#) [AH165-2SGLG1TE3](#) [AH165-TGFY22](#) [AH165-](#)
[TGL5Y11E3](#) [AH165-TGLR11AA3](#)