

产品型号	HX KCD3-2P	
订货号		
客户名称		
客户料号		
外观颜色	基座	黑色 B255
	按钮	黑色 B255
备注		

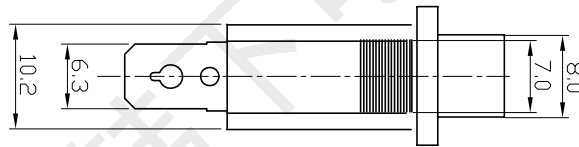
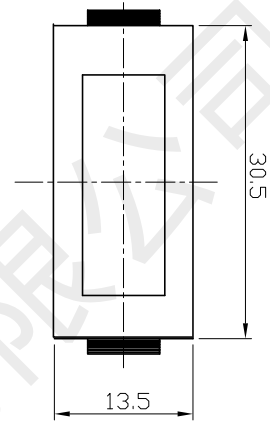
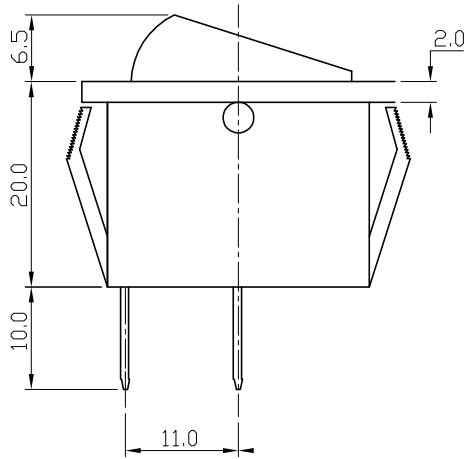

主要技术参数及性能

项目	参数
电路图	2P ON-OFF
额定电流电压	15A250V AC
绝缘电阻	≥100MΩ
接触电阻	<50mΩ
介电强度(极间)	≥1500VAC/min
(极对外壳)	≥3750VAC/min
电器寿命	≥10 ⁴ 次
环境温度	25T85

技术要求

1. 按动按钮应活动灵活，声音清脆，无阻滞、杂音等现象；
2. 注塑件表面光洁，无凹痕、熔接不良、银丝斑纹以及裂纹等表面缺陷；金属件无变形、锈蚀、镀层脱落以及其它机械损伤。



借 (通) 用 件 登 记	
旧底图总号	
底图总号	
签 字	
日 期	
档案员	日期

标记	外数	更改文件号	签字	日期
设计	黄彬			
制图				
审核	张伟			
工艺			批准	罗小春

船型开关		HX KCD3-2P		
		图样标记	重量	比例
				2.5:1



深圳市韩下电子有限公司



深圳市韩下电子有限公司

Shenzhen Hanxia Electronic Co., Ltd
Tel: 0755-33819206 Fax: 0755-27597491

承 认 书

SPECIFICATION FOR APPROVAL

客 户 Customer:

产品名称 Project:

船形开关

规格型号 Part No:

HX KCD3-2P

贵公司承认印 Approval signatures

料 号/Part No.	签 章/Signatures

日期 Date:

拟制/Drawn	黄彬	
审核/Check	张伟	
批准/Approved	罗小春	



产品规格书 PRODUCT SPECIFICATION

1. General Characteristics 一般特性

1.1 Application : This specification is applied to the mouse micro switch for general applications.

适用范围: 该承认书指船形开关的一般使用范围。

1.2 Operating Temperature Range: 0°C to +125°C
使用温度范围: 0°C ~ +125°C

1.3 Operating Relative Humidity: ≤85% RH
相对湿度: ≤85% RH

1.4 Test Conditions : Unless otherwise specified , the atmospheric conditions for making measurements and tested are as follows:

实验条件:若没有特别说明,则实验大气条件如下:

Ambient Temperature: 5 to 35°C

环境温度: 5 ~ 35°C

Relative Humidity: 45 to 85%

相对湿度: 45 to 85%

Air Pressure: 86 to 106Kpa(860~1060mbar)

大气压力: 86 to 106Kpa(860~1060mbar)

2. Appearance, Structure and Dimensions

外观, 结构及尺寸

2.1 Appearance : The switch shall have good finishing , and no rust , crack or plating defects

外观: 产品外观良好, 无锈蚀裂纹和镀层缺陷

2.2 Structure & Dimensions: Refer to individual product drawing .

结构及尺寸 参见产品图纸

Marking: Refer to individual product drawing .

标识: 参见产品图纸

3. Ratings

额定负荷 15 A 250VAC

4. Electrical Characteristics 电气特性

No	L tem 项目	Test Method 实验方法	Criteria 标准
4.1	Contact Resistance 接触电阻	Measured by a voltage drop method at 3A, 250 VAC. Any equipment with error not more than 5% can be used .resistance after test is the average of 5 successive measurements. 以 3A, 250V AC 直接电流, 采用电压降法测量。也可用误差不超过 5% 的仪表进行测量, 试验后的电阻取 5 次测量的平均值。	50mΩ Max
4.2	Insulation Resistance 绝缘电阻	500VDC voltage is applied between each pair of terminals and the terminal the metal frame for 60±5S. 相互绝缘的所有端子之间及各接线端子与外露的非载流金属零件之间加载 500V 直流电, 持续时间 60±5S.	100MΩ Min

4. Electrical Characteristics 电气特性			
No	Item 项目	Test Method 实验方法	Criteria 标准
4.3	Dielectric Voltage 抗电强度	1500VAC (50-60Hz, cut-off current 2mA) is applied between non-connected terminals and between terminals and the metal frame for 5S. 在相互绝缘的所有端子之间 1500V(50-60Hz) 交流电持续时间 5S.	No dielectric breakdown Shall occur 无击穿现象发生.
4.4	Mechanical Shock 冲击	<p>Switch shall be measured after following test:</p> <p>(1) Mounting Method :Normal (2) Acceleration:490m/S(50G) (3) Duration: 11ms (4) Test Direction: 6 directions</p>  <p>(5) Number of shocks: 3 times per direction(18times in total) 试件在下述参数条件下进行试验:</p> <p>(1) 安装方法:常规方法 (2) 加速度:490m/S(50G) (3) 时间: 11ms (4) 实验方向: 图 6 方向 (5) 冲击次数: 每个方向 3 次 (共 18 次)</p>	<p>After test Contact resistance:100mΩ Max Insulation resistance: 50MΩMin The electrical performance requirements specified in item 4.3 shall be satisfied. No abnormalities shall be recognized in appearance and construction. 试验后: 接触电阻: 100mΩ Max 绝缘电阻: 50MΩMin 电气性能符合第 4.3 条件的要求. 表面无变形且操作无异常.</p>
4.5	Solder Ability 可焊性	<p>Switch shall be checked after following test:</p> <p>(1) Solder:H63A(JIS Z3282) (2) Flux: Rosin Flux (JIS K 5902) having a nominal composition of 25 % solids by mass of water white rosin in methyl alcohol (JIS K 1501)solution (3) Soldering Temperature:235±5°C Immersing Time; 235±5°C Flux immersing time shall be 5~10s in normal room temperature. (4) Immersion Depth: Immersion depth shall be at copper plating portion If PCB after mounting, (Thickness of PCB=1.6mm) 试件在下述参数条件下进行试验:</p> <p>(1) 焊料: H63A (JIS Z3282) (2) 焊剂: 焊剂 (JIS K 5902), 质量百分比为 25%松香, 75%甲醇的无色透明溶液。 (3) 焊接温度: 235±5°C 浸入时间: 235±5°C 焊剂浸入时间: 5~10s (4) 浸入深度: 接线端子浸到离开开关根部 1.6mm 处。</p>	<p>More than 80% of immersed part shall Be covered with solder. 超过 80%的浸锡面积被焊料所覆盖。</p>

4. Electrical Characteristics 电气特性			
No	L tem 项目	Test Method 实验方法	Criteria 标准
4.6	Solder Heat Resistance 耐焊接热	Switch shall be checked after following test: (1) Solder:H63A(JIS Z3282) (2) Flux :Rosin Flux(JIS K 5902)having a nominal composition of 25% solids by mass of water white rosin in methyl alcohol (JIS K 1501)solution (3) Soldering Temperature & Immersing time Dip soldering 260±5℃ 5±1s Manual soldering 300±5℃ 2~3s (4) Immersion Depth(For dip soldering) Immersion depth shall be at copper plating portion If PCB after mounting. (试件在下列参数条件下进行试验: (1) 焊料: H63A(JIS Z3282) (2) 焊剂: 焊剂(JIS K 5902)质量百分比为 25%松香, 75%甲醇的无色透明溶液。 (3) 焊接温度及浸入时间 自动焊接: 260±5℃ 5±1s 手工焊接: 300±5℃ 2~3s (4) 浸入深度:(对于手动焊接) 接线端子到离开根部 1.6mm 处。	No abnormalities shall be observed In appearance and operation. The electrical performance requirements specified in item 4.3 shall be satisfied. 无外观及功能损坏 电气性能符合第 4.3 条件的要求。
4.7	Resistance To Flux 抗焊剂能力	Witch shall be checked after following test: (1) Solder:H63A(JIS Z3282) (2) Flux: Rosin Flux (JISK5902) having a nominal composition of 25% solids by mass of water white rosin in methyl alcohol (JISK1501)solution (3) Soldering Temperature:235±5℃ Immersing Time; 235±5℃ (4) Immersion Depth: Immersion depth shall be at copper plating portion If PCB after mounting, (Thickness of PCB=1.6mm) 试件在下列参数条件下进行试验: (1) 焊料: H63A (JIS Z3282) (2) 焊剂: 焊剂 (JIS K 5902), 质量百分比为 25%松香, 75%甲醇的无色透明溶液 (3) 焊接温度: 235±5℃焊剂浸入时间: 5~10s (4) 浸入深度: 接线端子浸到离开根部 1.6mm 处。	Flux shall not be risen up to contact. The switch shall be free from abnormalities in operation. 焊剂不得上升进入开头内部, 影响接触转换。 试件在操作过程中不应发生变形。
5.Durability characteristics 耐久性能			
No	L tem 项目	Test Method 实验方法	Criteria 标准
5.1	electric Life 电器寿命	10,000 cycles of operation shall be performed continuously at a rate of 80cycles per minute with 3A, 250V AC 在 3A , 250V AC 负荷的条件下, 速度 30 次/分, 在寿命试验设备上连续转换 10,000 次。	试验后: 接触电阻:500mΩ Max 绝缘电阻:10mΩMin 操作力衰变应在±30%以内。 电气性能符合第 4.3 条件的要求。 开关外观及结构应无损坏。

6. Weather proof characteristics 耐候性能

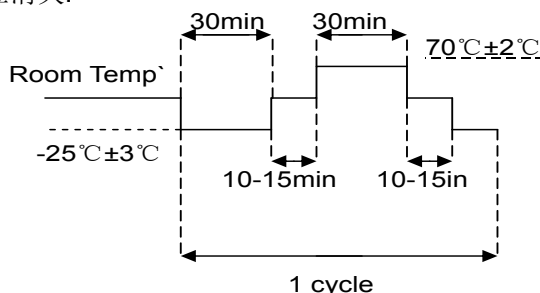
No	L tem 项目	Test Method 实验方法	Criteria 标准
6.1	Cold proof 低温	<p>After testing at $-20\pm 2^{\circ}\text{C}$ for 96hours, the switch shall be allowed to stand under normal temperature and humidity conditions for 1hour, and measurement shall be made within 1hour after that. water drops shall be eliminated.</p> <p>试件在$-20\pm 2^{\circ}\text{C}$的温控箱内保持 96 小时,然后在正常温度和湿度下恢复 1 小时,并在此后 1 小时内对试品进行测量,水滴应消失</p>	<p>After test</p> <p>Contact resistance:500mΩ Max</p> <p>Insulation resistance:10mΩMin</p> <p>Tolerance of operating force disintegration shall be within 30 % of specified value</p> <p>The electrical performance requirements specified in item 4.3 shall be satisfied.</p>
6.2	Hot proof 高温	<p>After testing at $85\pm 2^{\circ}\text{C}$for 96hours, the switch shall be allowed to stand under normal temperature and humidity conditions for 1hour, and measurement shall be made within 1hour after that. water drops shall be eliminated.</p> <p>试件在 $85\pm 2^{\circ}\text{C}$的温控箱内保持 96 小时,然后在正常温度和湿度下恢复 1 小时,并在此后 1 小时内对试品进行测量,水滴应消失.</p>	<p>The switch shall be free from abnormalities in appearance construction.</p> <p>试验后:</p> <p>接触电阻:500mΩ Max</p> <p>绝缘电阻:10mΩMin</p> <p>操作力衰变应在$\pm 30\%$以内.</p> <p>电气性能符合第 4.3 条件的要求 .</p> <p>开关外观及结构应无损坏.</p>
6.3	Moisture Resistance 恒定湿热	<p>After testing at $40\pm 2^{\circ}\text{C}$ 90~95% RH for 96hourd, the switch shall be allowed to stand under normal temperature and humidity conditions for 1hour, and measurement shall be made within 1hour after that, water drops shall be eliminated.</p> <p>试件在 $40\pm 2^{\circ}\text{C}$ 90~95% RH 的温控箱内保持 96 小 时,然后在正常温度和湿度下恢复 1 小时,并在此后 1 小时内对试品进行测量,水滴应消失.</p>	<p>After test</p> <p>Contactresistance:500mΩ Max</p> <p>Insulation resistance:10mΩ Min</p> <p>Tolerance of operating force disintegration shall be within 30% of specified value The electrical performance requirements specified in item 4.3 shall be satisfied.The switch shall be free from abnormalities in appearance construction.</p> <p>试验后:</p> <p>接触电阻:500mΩ Max</p> <p>绝缘电阻:10mΩMin</p> <p>操作力衰变应在$\pm 30\%$以内.</p> <p>电气性能符合第 4.3 条件的要求. 开关外观及结构应无损坏.</p>
6.4	Temperature Cycling 温度转换	<p>After 5 cycles of following conditions, the switch shall be allowed to stand under normal temperature and humidity conditions for 1hour, and measurement shall be made within 1hour after that. water drops shall be eliminated.</p> <p>试件按下述实验条件试验 5 次,然后在正常温度和湿度下恢复 1 小时,并在此后 1 小内对试品进行测量,水滴应消失.</p> 	<p>After test</p> <p>contact resistance:100mΩMax</p> <p>Insulation resistance:10mΩMin</p> <p>The electrical performance requirements specified in item 4.3 shall be satisfied.</p> <p>The switch shall be free from abnormalities in appearance construction.</p> <p>试验后:</p> <p>接触电阻:100mΩMax</p> <p>绝缘电阻:10mΩMin</p> <p>电气性能符合第 4.3 条件的要求,开关外观及结构应无损坏</p>

6.Weather proof characteristics 耐候性能			
No	L tem 项目	Test Method 实验方法	Criteria 标准
6.5	Salt mist 盐雾试验	<p>The switch shall be checked after following test:</p> <p>(1) Temperature:35±2℃ (2) Salt solution:5±1%(Solids by mass) (3) Duration: 24±1hour</p> <p>After test, salt deposit shall be removed by running water. 试件在下列实验后测量:</p> <p>(1) 温度:35±2℃ (2) 盐溶液浓度:5±1%(Solids by mass) (3) 时间: 24±1hour 实验后的盐沉积物用水冲掉.</p>	<p>No remarkable corrosion shall be recognized in metal part. 在金属件上没有腐蚀斑点.</p>
6.6	Temperature Cycling 温度转换	<p>DC Voltage 1.5 times as much as rated voltage shall be applied continuously between adjacent at 60±2℃ and 90~95%RH for 500hours, the switch shall be allowed to stand under normal temperature and humidity conditions for 1hour, and measurement shall be made within 1hour after that, water drops shall be eliminated. 试件每个相邻端子之间连续加载 1.5 倍于额定电压的直流电压 60±2℃ 90~95%RH 的温控箱内保持 500 小时,然后在正常温度和湿度下恢复 1 小时,并在此后 1 小时内对试品进行测量,水滴应消失.</p>	<p>After test contact resistance:100mΩMax Insulation resistance:10mΩMin The electrical performance requirements specified in item 4.3 shall be satisfied. The switch shall be free from abnormalities in appearance construction. 试验后: 接触电阻:100mΩMax 绝缘电阻:10mΩMin 电气性能符合第 4.3 条件的要求,开关外观及结构应无损坏/</p>

X-ON Electronics

Largest Supplier of Electrical and Electronic Components

Click to view similar products for [Rocker Switches](#) category:

Click to view products by [hanxia](#) manufacturer:

Other Similar products are found below :

[LTILA6E-1S-WH-RC-FN12VXCR1](#) [6-1571986-9](#) [8007K26N324V52](#) [8055K23Z7V](#) [8055K32Z7V](#) [8055K52Z7V](#) [8138K20E6M50](#)
[PREDD4-07F-BB0FW](#) [PREDD5-07F-BB0GW](#) [999-16716-002](#) [A101J1V3Q004](#) [A103J1ZQ004](#) [A201J1AQ004](#) [A201J50ZQ004](#)
[H8653VBBG2577W](#) [HB130CHNWWNAAC](#) [R13112ABB-602W](#) [1251.0303](#) [1352.0107](#) [1500G51E](#) [1571099-3](#) [1571987-4](#) [1571987-5](#)
[1571988-5](#) [B123J77V7B2](#) [160212E](#) [1634200-7](#) [1801.1164](#) [PANEL-PLUG-VHP-BLACK](#) [PANEL-PLUG-VHP-WT](#) [K2ABAAAAAA](#)
[250011E714](#) [2600R21E](#) [260413E](#) [2639LH/2A7/127000L0](#) [LL3AZXX-100-XGT1](#) [LL3AZXX-100-XHS1](#) [LL3AZXX-100-XSD1](#) [30-695B](#)
[160311E](#) [A103J3ZQ004](#) [A201J61ZQ0004](#) [1852.1102](#) [1890.1104](#) [191.081.011](#) [AE107J1AQ004](#) [1935.3128](#) [1935.3133](#) [1MR7-B](#)
[SY236CD6U622](#)