

# JST25 Series 25A TRIACs

## DESCRIPTION:

High current density due to double mesa technology, SIPOS and Glass Passivation.

JST25A/JST25B/JST25Z series triacs is suitable for general purpose AC switching, They can be used as an ON/OFF function in applications such as static relays, heating regulation, induction motor starting circuits... or for phase control operation, light dimmers, motor speed controllers.

JST25-CW-BW Series are 3 quadrants triacs, They are specially recommended for use on inductive loads.

JST25A JST25Z series provide a 2500V RMS isolation voltage from all three terminals to external heat sink.

## MAIN FEATURES

| Symbol            | Value     | Unit |
|-------------------|-----------|------|
| $I_{T(RMS)}$      | 25        | A    |
| $V_{DRM}/V_{RRM}$ | 600 / 800 | V    |
| $V_{TM}$          | 1.5       | V    |

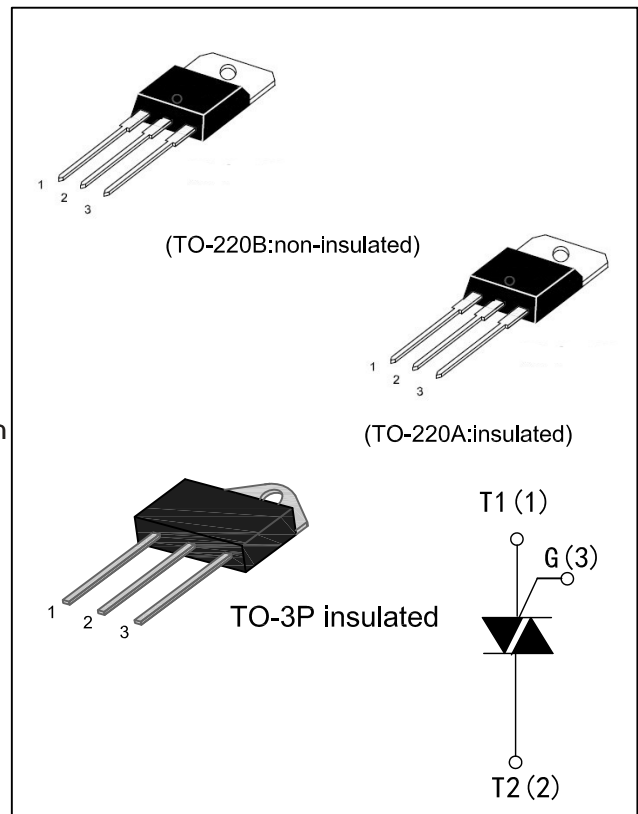

## ABSOLUTE MAXIMUM RATINGS

| Parameter   |                                  | Symbol                 | Value         | Unit                   |
|---|----------------------------------|------------------------|---------------|------------------------|
| Storage junction temperature range  |                                  | $T_{stg}$              | -40 to +150   | °C                     |
| Operating junction temperature range  |                                  | $T_j$                  | -40 to +125   | °C                     |
| Repetitive Peak Off-state Voltage ( $T_j=25^\circ\text{C}$ )<br>Repetitive Peak Reverse Voltage ( $T_j=25^\circ\text{C}$ )        | JST25x06                         | $V_{DRM}$<br>$V_{RRM}$ | 600           | V                      |
|   | JST25x08                         |                        | 800           |                        |
|   |                                  |                        |               |                        |
| Non repetitive Surge Peak Off-state Voltage ( $t_p=10\text{ms}, T_j=25^\circ\text{C}$ )   |                                  | $V_{DSM}$              | $V_{DRM}+100$ | V                      |
| Non repetitive Peak Reverse Voltage ( $t_p=10\text{ms}, T_j=25^\circ\text{C}$ )   |                                  | $V_{RSM}$              | $V_{RRM}+100$ |                        |
| RMS on-state current (full sine wave)   | TO-220A $T_c=75^\circ\text{C}$   | $I_{T(RMS)}$           | 25            | A                      |
|   | TO-220B $T_c=100^\circ\text{C}$  |                        |               |                        |
| Non repetitive surge peak on-state current (full cycle, $T_j=25^\circ\text{C}$ )  | $f=60\text{Hz}, t=16.7\text{ms}$ | $I_{TSM}$              | 260           | A                      |
|   | $f=50\text{Hz}, t=20\text{ms}$   |                        | 250           |                        |
| $I^2t$ Value for fusing   | $t_p=10\text{ms}$                | $I^2t$                 | 340           | $\text{A}^2\text{s}$   |
| Critical rate of rise of on-state current ( $I_G=2 \times I_{GT}, t_r \leq 100\text{ns}, f=120\text{Hz}, T_j=125^\circ\text{C}$ ) |                                  | $di/dt$                | 50            | $\text{A}/\mu\text{s}$ |
| Peak gate current ( $t_p=20\mu\text{s}, T_j=125^\circ\text{C}$ )  |                                  | $I_{GM}$               | 4             | A                      |
| Peak Gate Power Dissipation ( $t_p=20\mu\text{s}, T_j=125^\circ\text{C}$ )  |                                  | $P_{GM}$               | 10            | W                      |
| Average gate power dissipation ( $T_j=125^\circ\text{C}$ )  |                                  | $P_{G(AV)}$            | 1             | W                      |

ELECTRICAL CHARACTERISTICS(T<sub>j</sub>=25°C unless otherwise specified)

| Symbol               | Test Condition   | Quadrant |      | Limits |       | Unit |
|----------------------|--|----------|------|--------|-------|------|
|                      |  |          |      | CW(C)  | BW(B) |      |
| I <sub>GT</sub>      | V <sub>D</sub> =12V R <sub>L</sub> =33Ω                                      | I-II-III | MAX. | 35     | 50    | mA   |
| V <sub>GT</sub>      |  | I-II-III | MAX. | 1.3    |       | V    |
| V <sub>GD</sub>      | V <sub>D</sub> =V <sub>DRM</sub> R <sub>L</sub> =3.3KΩ T <sub>j</sub> =125°C | I-II-III | MIN. | 0.2    |       | V    |
| I <sub>L</sub>       | I <sub>G</sub> =1.2I <sub>GT</sub>   | I-III    | MAX. | 70     | 80    | mA   |
|                      |  | II       | MAX. | 80     | 100   | mA   |
| I <sub>H</sub>       | I <sub>T</sub> =100mA  |          | MAX. | 50     | 75    | mA   |
| dV/dt                | V <sub>D</sub> =67%V <sub>DRM</sub> gate open T <sub>j</sub> =125°C          |          | MIN. | 500    | 1000  | V/μs |
| (di/dt) <sub>c</sub> | Without snubber T <sub>j</sub> =125°C  |          | MIN. | 13     | 22    | A/ms |

STATIC CHARACTERISTICS

| Symbol                               | Parameter   |                       | Value(MAX.) | Unit |
|--------------------------------------|---|-----------------------|-------------|------|
| V <sub>TM</sub>                      | I <sub>TM</sub> =35A, t <sub>p</sub> =380μs                       | T <sub>j</sub> =25°C  | 1.5         | V    |
| I <sub>DRM</sub><br>I <sub>RRM</sub> | V <sub>D</sub> =V <sub>DRM</sub> V <sub>R</sub> =V <sub>RRM</sub> | T <sub>j</sub> =25°C  | 5           | μA   |
|                                      |   | T <sub>j</sub> =125°C | 3           | mA   |

THERMAL RESISTANCES

| Symbol               | Parameter                                    |         | Value | Unit |
|----------------------|--|---------|-------|------|
| R <sub>th(j-c)</sub> | Junction to Case(AC)                         | TO-220A | 1.7   | °C/W |
|                      |  | TO-220B | 0.8   |      |
| R <sub>th(j-a)</sub> | Junction to ambient<br>(S=1cm <sup>2</sup> ) | TO-220A | 60    | °C/W |
|                      |  | TO-220B | 60    |      |

ORDERING INFORMATION

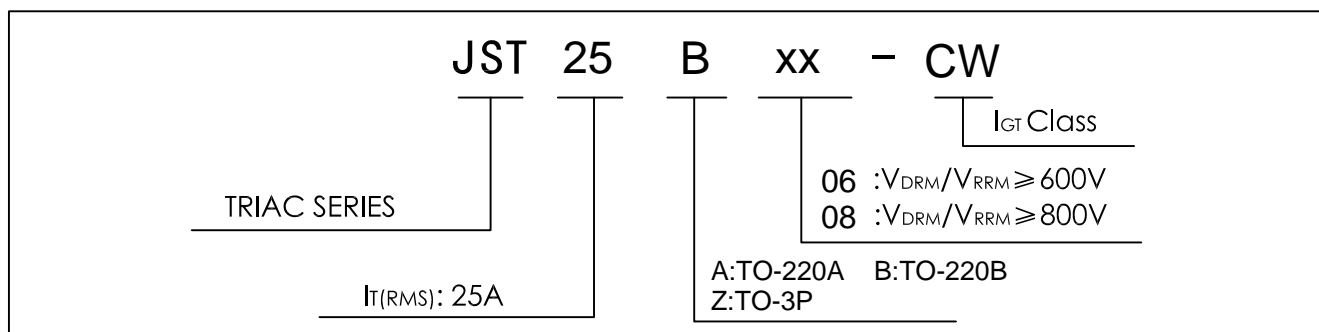

PACKAGE MECHANICAL DATA

TO-220A insulated package and TO-220B non-insulated package

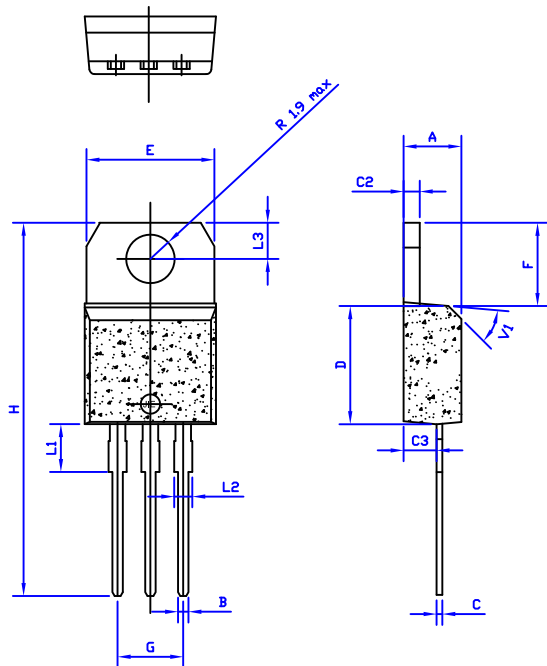

| Ref. | Dimensions  |      |      |        |       |       |
|------|-------------|------|------|--------|-------|-------|
|      | Millimeters |      |      | Inches |       |       |
|      | Min.        | Typ. | Max. | Min.   | Typ.  | Max.  |
| A    | 4.4         |      | 4.6  | 0.173  |       | 1.181 |
| B    | 0.61        |      | 0.88 | 0.024  |       | 0.034 |
| C    | 0.46        |      | 0.70 | 0.018  |       | 0.027 |
| C2   | 1.23        |      | 1.32 | 0.048  |       | 0.051 |
| C3   | 2.4         |      | 2.72 | 0.094  |       | 0.107 |
| D    | 8.6         |      | 9.7  | 0.338  |       | 0.382 |
| E    | 9.8         |      | 10.4 | 0.386  |       | 0.409 |
| F    | 6.2         |      | 6.6  | 0.244  |       | 0.259 |
| G    | 4.8         |      | 5.4  | 0.189  |       | 0.213 |
| H    | 28.0        |      | 29.8 | 11.0   |       | 11.7  |
| L1   |             | 3.75 |      |        | 0.147 |       |
| L2   | 1.14        |      | 1.7  | 0.044  |       | 0.066 |
| L3   | 2.65        |      | 2.95 | 0.104  |       | 0.116 |
| V1   |             | 40°  |      |        | 40°   |       |

TO-3P

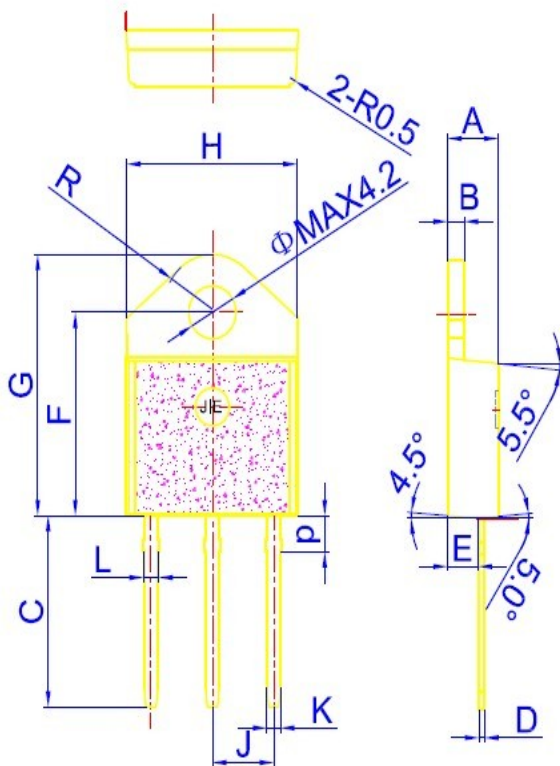

| Ref. | Dimensions  |      |      |        |       |       |
|------|-------------|------|------|--------|-------|-------|
|      | Millimeters |      |      | Inches |       |       |
|      | Min.        | Typ. | Max. | Min.   | Typ.  | Max.  |
| A    | 4.4         |      | 4.6  | 0.173  |       | 0.181 |
| B    | 1.45        |      | 1.55 | 0.057  |       | 0.061 |
| C    | 14.35       |      | 15.6 | 0.565  |       | 0.614 |
| D    | 0.5         |      | 0.7  | 0.020  |       | 0.028 |
| E    | 2.7         |      | 2.9  | 0.106  |       | 0.114 |
| F    | 15.8        |      | 16.5 | 0.622  |       | 0.650 |
| G    | 20.4        |      | 21.1 | 0.815  |       | 0.831 |
| H    | 15.1        |      | 15.5 | 0.594  |       | 0.610 |
| J    | 5.4         |      | 5.65 | 0.213  |       | 0.222 |
| K    | 1.2         |      | 1.4  | 0.047  |       | 0.055 |
| L    | 1.35        |      | 1.50 | 0.053  |       | 0.059 |
| P    | 2.8         |      | 3.0  | 0.110  |       | 0.118 |
| R    |             | 4.6  |      |        | 0.181 |       |

FIG.1:Maximum power dissipation versus RMS on-state current(full cycle)

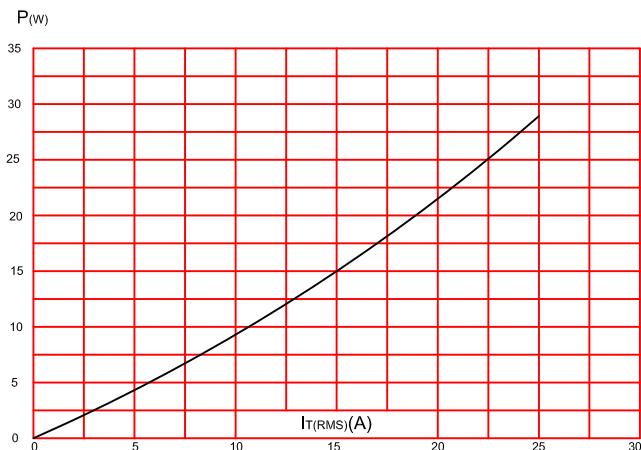

FIG.2:RMS on-state current versus case temperature(full cycle)

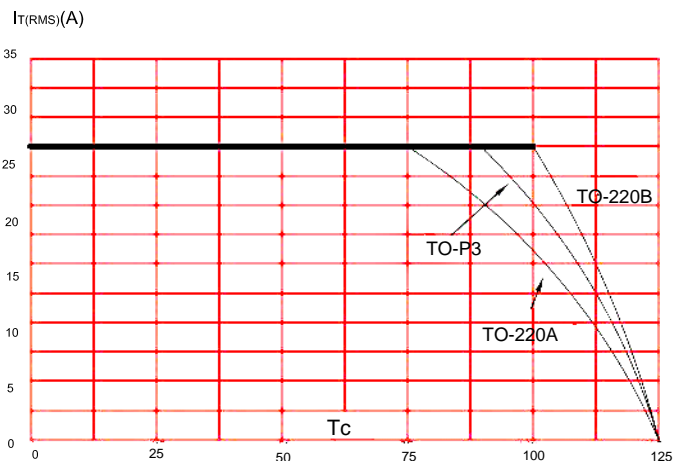

FIG.3:On-state characteristics (maximum values).

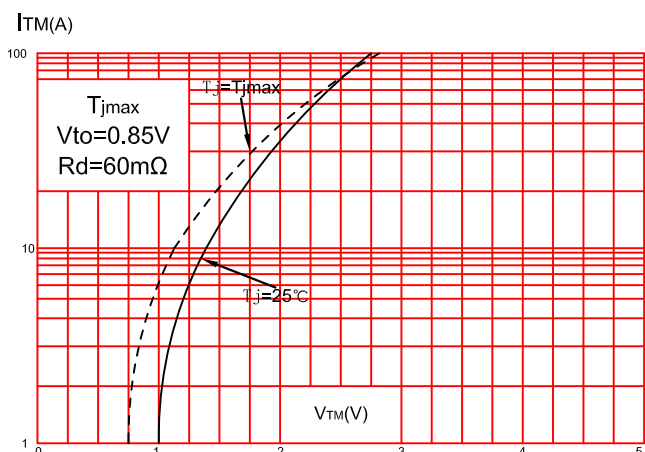

FIG.4:Surge peak on-state current versus number of cycles.

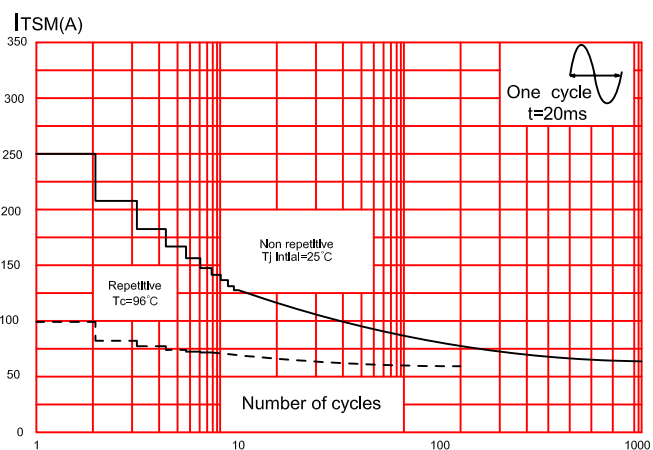

FIG.5:Non-repetitive surge peak on-state current for a sinusoidal pulse with width  $t_p < 10ms$ , and corresponding value of  $I^2t$ .

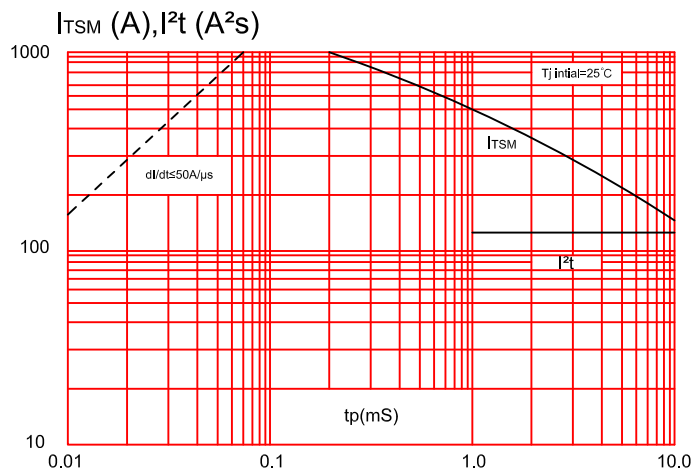
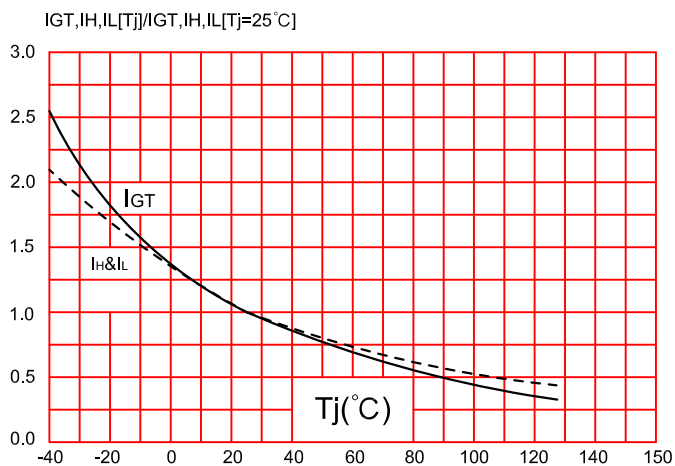

FIG.6:Relative variations of gate trigger current, holding current and latching current versus junction temperature(typical values)



## X-ON Electronics

Largest Supplier of Electrical and Electronic Components

*Click to view similar products for [Triacs](#) category:*

*Click to view products by [Haoruijia](#) manufacturer:*

Other Similar products are found below :

[BT137-600-0Q](#) [OT415Q](#) [2N6075A](#) [NTE5688](#) [BTA2008W-800D,135](#) [D31410](#) [QJ8006NH4TP](#) [QJ8010NH5TP](#) [QJ8008NH4TP](#)  
[QJ8006NH4RP](#) [QJ8010RH5TP](#) [QJ8010NH4TP](#) [QJ8006LH4TP](#) [BT136-600,127](#) [BT137B-800,118](#) [BT138-800E,127](#) [BTA140-600,127](#)  
[BTA208-800B,127](#) [BTA225-800B,127](#) [MAC97A6,116](#) [BTA420-800BT,127](#) [BTA201W-800E,115](#) [BTA212B-800B,118](#) [MCR100-8](#) [100-8](#)  
[MCR100-6](#) [MCR100-8](#) [BT151-650R](#) [BT136-800E](#) [BTA12-800B](#) [BT169-23](#) [MAC97A6-23-3L](#) [BT139-800E](#) [MCR100-8](#) [MCR100-6](#)  
[BTA408X-1000C0T,127](#) [BTA20](#) [MCR100-6](#) [BTA316X-800CTQ](#) [TYN612](#) [X0405MF-202-3](#) [MCR100-6](#) [100-6](#) [BTA26-800B](#) [MCR100-8](#)  
[MCR18](#) [BTA16-800B](#) [BTA20-800B](#) [BTA16-800SW](#) [TYN616](#) [JST130L-600D](#) [AG-BK](#)